

# 54F/74F374 Octal D-Type Flip-Flop with TRI-STATE® Outputs

## General Description

The 'F374 is a high-speed, low-power octal D-type flip-flop featuring separate D-type inputs for each flip-flop and TRI-STATE outputs for bus-oriented applications. A buffered Clock (CP) and Output Enable (OE) are common to all flip-flops.

## Features

- Edge-triggered D-type inputs
- Buffered positive edge-triggered clock
- TRI-STATE outputs for bus-oriented applications
- Guaranteed 4000V minimum ESD protection

Commercial	Military	Package Number	Package Description
74F374PC		N20A	20-Lead (0.300" Wide) Molded Dual-In-Line
	54F374DM (QB)	J20A	20-Lead Ceramic Dual-In-Line
74F374SC (Note 1)		M20B	20-Lead (0.300" Wide) Molded Small Outline, JEDEC
74F374SJ (Note 1)		M20D	20-Lead (0.300" Wide) Molded Small Outline, EIAJ
74F374MSA (Note 1)		MSA20	20-Lead Molded Shrink Small Outline, EIAJ Type II
	54F374FM (QB)	W20A	20-Lead Cerpack
	54F374LM (QB)	E20A	20-Lead Ceramic Leadless Chip Carrier, Type C

Note 1: Devices also available in 13" reel. Use suffix = SCX, SJX, and MSAX.

## Logic Symbols

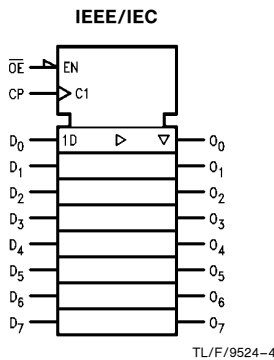
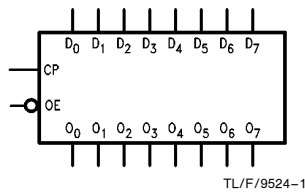

## Connection Diagrams

Pin Assignment for DIP, SOIC, SSOP and Flatpak

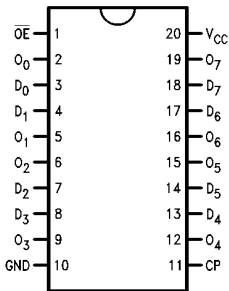

Pin Assignment for LCC

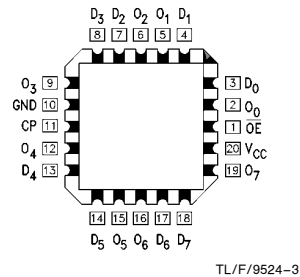

TRI-STATE® is a registered trademark of National Semiconductor Corporation.



## Unit Loading/Fan Out

Pin Names	Description	54F/74F	
		U.L. HIGH/LOW	Input $I_{IH}/I_{IL}$ Output $I_{OH}/I_{OL}$
D <sub>0</sub> –D <sub>7</sub>	Data Inputs	1.0/1.0	20 $\mu$ A/ –0.6 mA
CP	Clock Pulse Input (Active Rising Edge)	1.0/1.0	20 $\mu$ A/ –0.6 mA
$\overline{OE}$	TRI-STATE Output Enable Input (Active LOW)	1.0/1.0	20 $\mu$ A/ –0.6 mA
O <sub>0</sub> –O <sub>7</sub>	TRI-STATE Outputs	150/40 (33.3)	–3 mA/24 mA (20 mA)

## Functional Description

The 'F374 consists of eight edge-triggered flip-flops with individual D-type inputs and TRI-STATE true outputs. The buffered clock and buffered Output Enable are common to all flip-flops. The eight flip-flops will store the state of their individual D inputs that meet the setup and hold time requirements on the LOW-to-HIGH Clock (CP) transition. With the Output Enable ( $\overline{OE}$ ) LOW, the contents of the eight flip-flops are available at the outputs. When the  $\overline{OE}$  is HIGH, the outputs go to the high impedance state. Operation of the  $\overline{OE}$  input does not affect the state of the flip-flops.

## Truth Table

Inputs			Internal Register	Output
D <sub>n</sub>	CP	$\overline{OE}$		O <sub>n</sub>
H		L	H	H
L		L	L	L
X	X	H	X	Z

H = HIGH Voltage Level  
 L = LOW Voltage Level  
 X = Immaterial  
 Z = High Impedance  
 = LOW-to-HIGH Clock Transition

## Logic Diagram

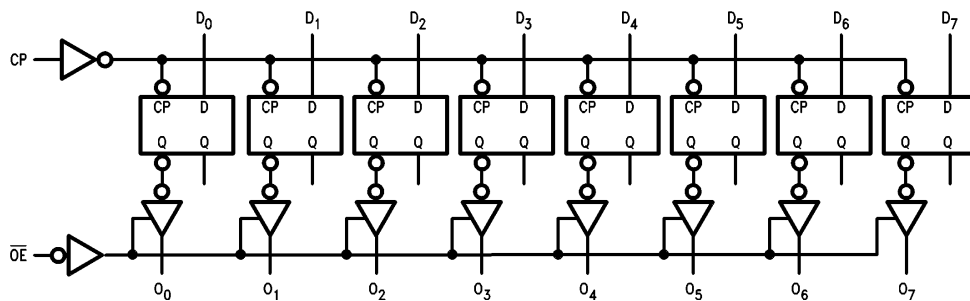

TL/F/9524–5

Please note that this diagram is provided only for the understanding of logic operations and should not be used to estimate propagation delays.

## Absolute Maximum Ratings (Note 1)

If Military/Aerospace specified devices are required, please contact the National Semiconductor Sales Office/Distributors for availability and specifications.

Storage Temperature	-65°C to +150°C
Ambient Temperature under Bias	-55°C to +125°C
Junction Temperature under Bias	-55°C to +175°C
Plastic	-55°C to +150°C
V <sub>CC</sub> Pin Potential to Ground Pin	-0.5V to +7.0V
Input Voltage (Note 2)	-0.5V to +7.0V
Input Current (Note 2)	-30 mA to +5.0 mA
Voltage Applied to Output in HIGH State (with V <sub>CC</sub> = 0V)	
Standard Output	-0.5V to V <sub>CC</sub>
TRI-STATE Output	-0.5V to +5.5V
Current Applied to Output in LOW State (Max)	twice the rated I <sub>OL</sub> (mA)

ESD Last Passing Voltage (Min) 4000V

**Note 1:** Absolute maximum ratings are values beyond which the device may be damaged or have its useful life impaired. Functional operation under these conditions is not implied.

**Note 2:** Either voltage limit or current limit is sufficient to protect inputs.

## Recommended Operating Conditions

Free Air Ambient Temperature	
Military	-55°C to +125°C
Commercial	0°C to +70°C
Supply Voltage	
Military	+4.5V to +5.5V
Commercial	+4.5V to +5.5V

## DC Electrical Characteristics

Symbol	Parameter	54F/74F			Units	V <sub>CC</sub>	Conditions
		Min	Typ	Max			
V <sub>IH</sub>	Input HIGH Voltage	2.0			V		Recognized as a HIGH Signal
V <sub>IL</sub>	Input LOW Voltage				V		Recognized as a LOW Signal
V <sub>CD</sub>	Input Clamp Diode Voltage				V	Min	I <sub>IN</sub> = -18 mA
V <sub>OH</sub>	Output HIGH Voltage	54F 10% V <sub>CC</sub>	2.5		V	Min	I <sub>OH</sub> = -1 mA
		54F 10% V <sub>CC</sub>	2.4				I <sub>OH</sub> = -3 mA
		74F 10% V <sub>CC</sub>	2.5				I <sub>OH</sub> = -1 mA
		74F 10% V <sub>CC</sub>	2.4				I <sub>OH</sub> = -3 mA
		74F 5% V <sub>CC</sub>	2.7				I <sub>OH</sub> = -1 mA
		74F 5% V <sub>CC</sub>	2.7				I <sub>OH</sub> = -3 mA
V <sub>OL</sub>	Output LOW Voltage	54F 10% V <sub>CC</sub>			V	Min	I <sub>OL</sub> = 20 mA
		74F 10% V <sub>CC</sub>					I <sub>OL</sub> = 24 mA
I <sub>IH</sub>	Input HIGH Current	54F	20.0		μA	Max	V <sub>IN</sub> = 2.7V
		74F	5.0				
I <sub>BVI</sub>	Input HIGH Current Breakdown Test	54F	100		μA	Max	V <sub>IN</sub> = 7.0V
		74F	7.0				
I <sub>CEX</sub>	Output HIGH Leakage Current	54F	250		μA	Max	V <sub>OUT</sub> = V <sub>CC</sub>
		74F	50				
V <sub>ID</sub>	Input Leakage Test	74F	4.75		V	0.0	I <sub>ID</sub> = 1.9 μA All Other Pins Grounded
I <sub>OD</sub>	Output Leakage Circuit Current	74F	3.75		μA	0.0	V <sub>ID</sub> = 150 mV All Other Pins Grounded
I <sub>IL</sub>	Input LOW Current				mA	Max	V <sub>IN</sub> = 0.5V
I <sub>OZH</sub>	Output Leakage Current				μA	Max	V <sub>OUT</sub> = 2.7V
I <sub>OZL</sub>	Output Leakage Current				μA	Max	V <sub>OUT</sub> = 0.5V
I <sub>OS</sub>	Output Short-Circuit Current	-60		-150	mA	Max	V <sub>OUT</sub> = 0V
I <sub>ZZ</sub>	Bus Drainage Test				μA	0.0V	V <sub>OUT</sub> = 5.25V
I <sub>CCZ</sub>	Power Supply Current	55		86	mA	Max	V <sub>O</sub> = HIGH Z

## AC Electrical Characteristics

Symbol	Parameter	74F			54F		74F		Units
		T <sub>A</sub> = +25°C V <sub>CC</sub> = +5.0V C <sub>L</sub> = 50 pF			T <sub>A</sub> , V <sub>CC</sub> = Mil C <sub>L</sub> = 50 pF		T <sub>A</sub> , V <sub>CC</sub> = Com C <sub>L</sub> = 50 pF		
		Min	Typ	Max	Min	Max	Min	Max	
f <sub>max</sub>	Maximum Clock Frequency	100	140		60		70		MHz
t <sub>PLH</sub> t <sub>PHL</sub>	Propagation Delay CP to O <sub>n</sub>	4.0	6.5	8.5	4.0	10.5	4.0	10.0	ns
t <sub>PZH</sub> t <sub>PZL</sub>	Output Enable Time	2.0	9.0	11.5	2.0	14.0	2.0	12.5	ns
t <sub>PHZ</sub> t <sub>PLZ</sub>	Output Disable Time	2.0	5.3	7.0	2.0	8.0	2.0	8.0	
		1.5	4.3	5.5	1.5	7.5	1.5	6.5	

## AC Operating Requirements

Symbol	Parameter	74F		54F		74F		Units
		T <sub>A</sub> = +25°C V <sub>CC</sub> = +5.0V		T <sub>A</sub> , V <sub>CC</sub> = Mil		T <sub>A</sub> , V <sub>CC</sub> = Com		
		Min	Max	Min	Max	Min	Max	
t <sub>s</sub> (H) t <sub>s</sub> (L)	Setup Time, HIGH or LOW D <sub>n</sub> to CP	2.0		2.5		2.0		ns
t <sub>h</sub> (H) t <sub>h</sub> (L)	Hold Time, HIGH or LOW D <sub>n</sub> to CP	2.0		2.0		2.0		
t <sub>w</sub> (H) t <sub>w</sub> (L)	CP Pulse Width HIGH or LOW	7.0		7.0		7.0		ns
		6.0		6.0		6.0		

## Ordering Information

The device number is used to form part of a simplified purchasing code where the package type and temperature range are defined as follows:

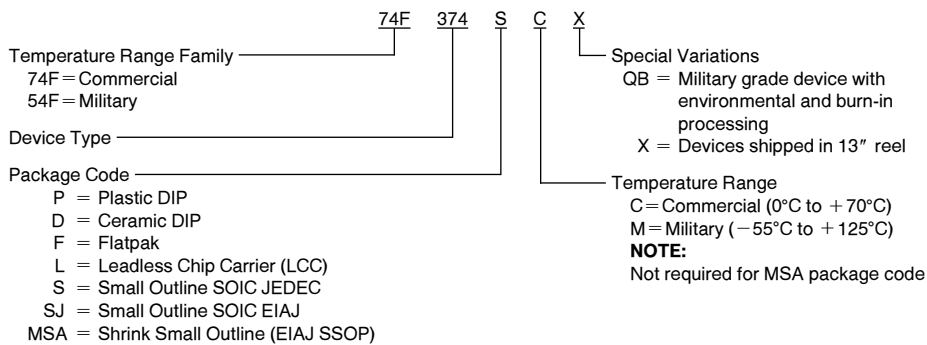

**Physical Dimensions** inches (millimeters)

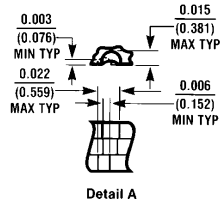
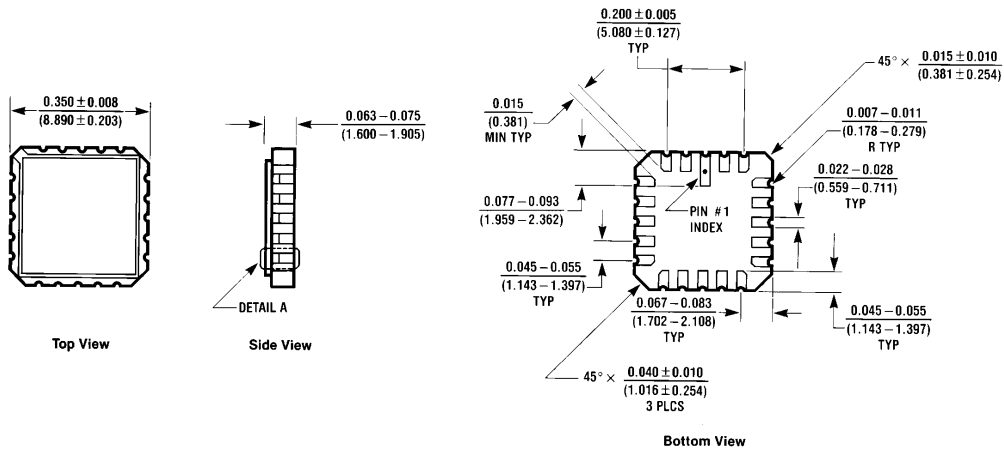

**20-Lead Ceramic Leadless Chip Carrier (L)**  
 NS Package Number E20A

E20A (REV D)

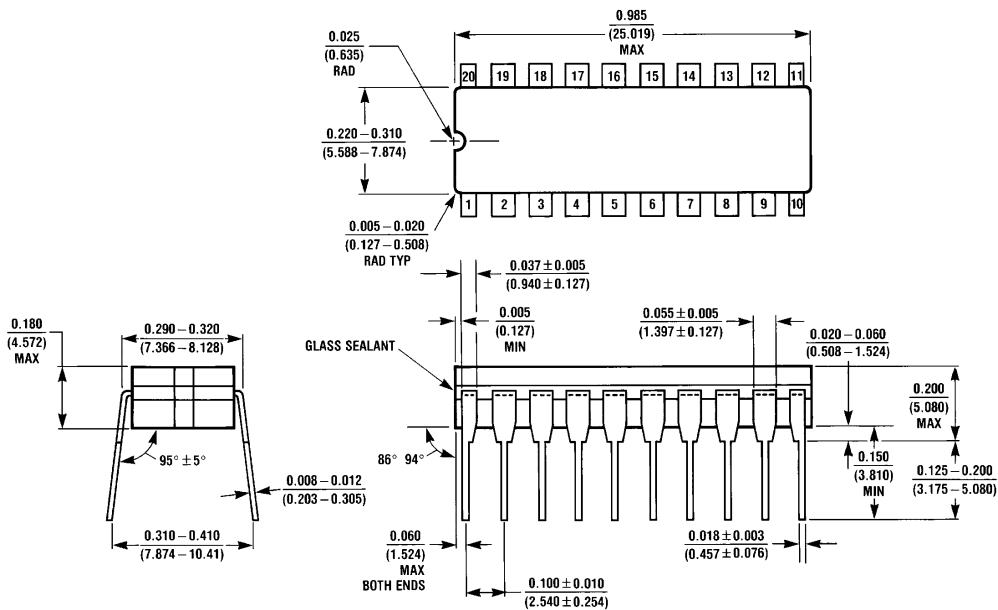

**20-Lead Ceramic Dual-In-Line Package (D)**  
 NS Package Number J20A

J20A (REV M)

**Physical Dimensions** inches (millimeters) (Continued)

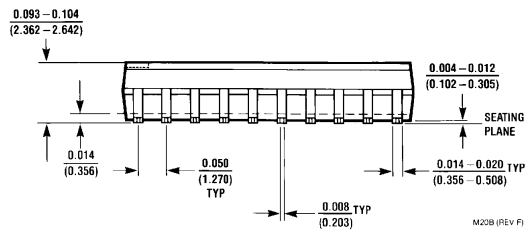
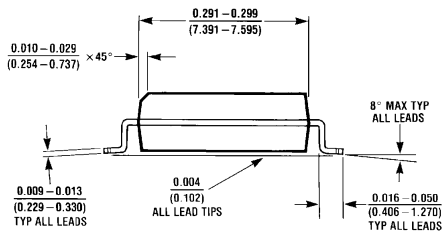
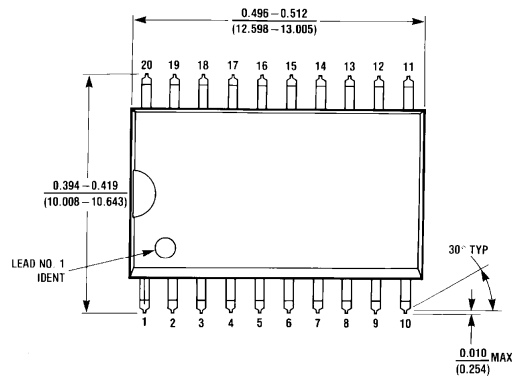

**20-Lead (0.300" Wide) Molded Small Outline Package, JEDEC (S)  
NS Package Number M20B**

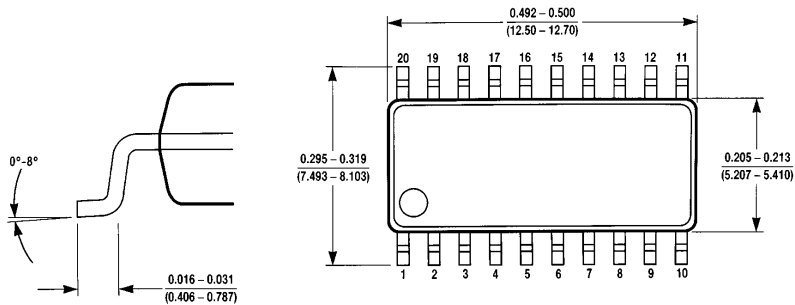

**DETAIL F**

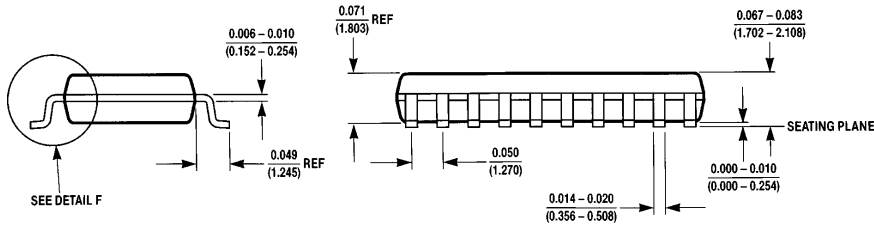

**SEE DETAIL F**

**20-Lead (0.300" Wide) Molded Small Outline Package, EIAJ (SJ)  
NS Package Number M20D**

**Physical Dimensions** inches (millimeters) (Continued)

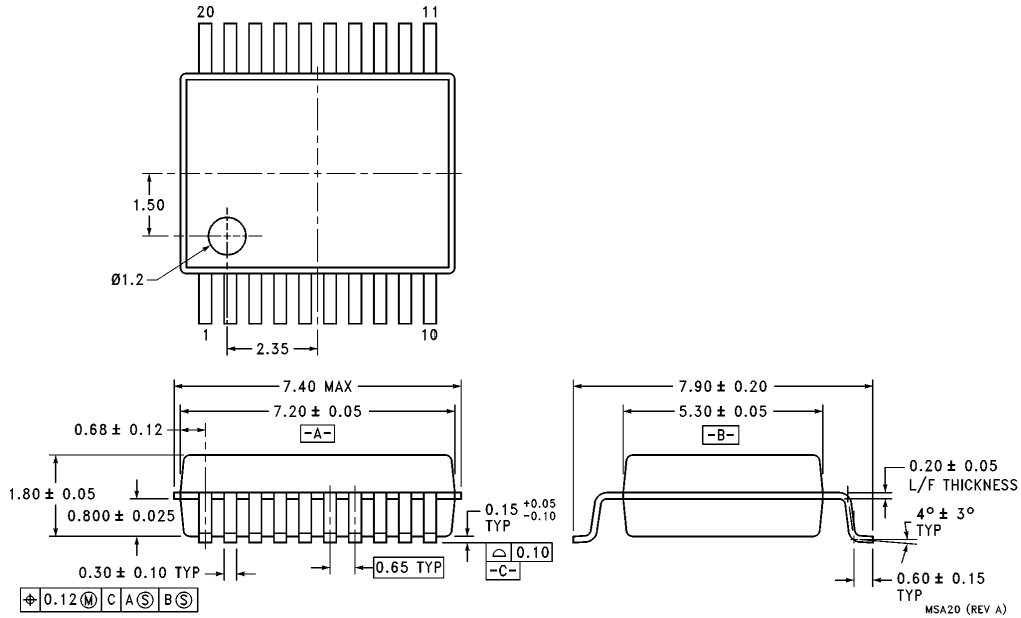

**20-Lead (0.300" Wide) Molded Shrink Small Outline Package, EIAJ, Type II (MSA)**  
NS Package Number MSA20

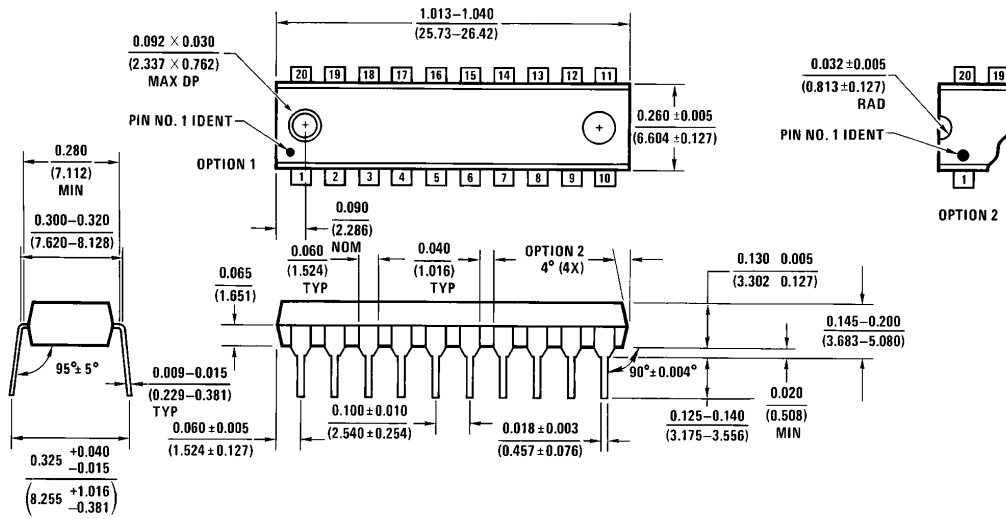

**20-Lead (0.300" Wide) Molded Dual-In-Line Package (P)**  
NS Package Number N20A

**Physical Dimensions** inches (millimeters) (Continued)

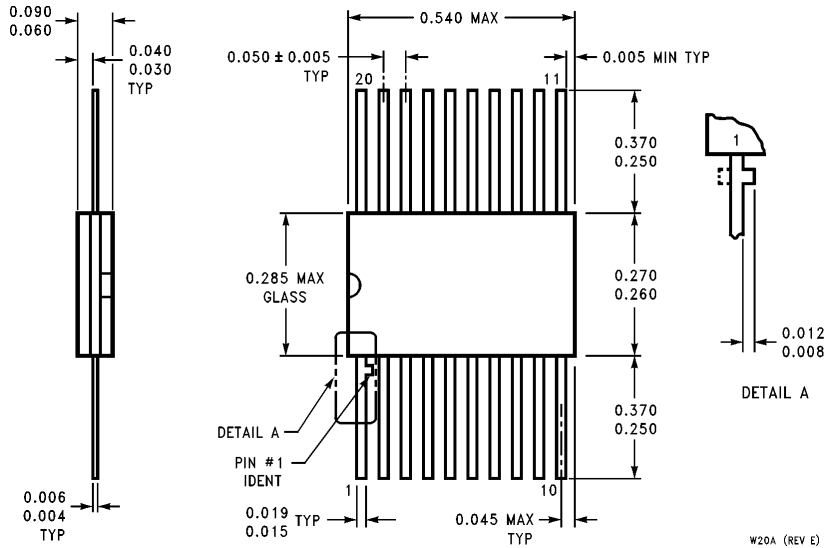

**20-Lead Ceramic Flatpak (F)  
NS Package Number W20A**

W20A (REV E)

**LIFE SUPPORT POLICY**

NATIONAL'S PRODUCTS ARE NOT AUTHORIZED FOR USE AS CRITICAL COMPONENTS IN LIFE SUPPORT DEVICES OR SYSTEMS WITHOUT THE EXPRESS WRITTEN APPROVAL OF THE PRESIDENT OF NATIONAL SEMICONDUCTOR CORPORATION. As used herein:

1. Life support devices or systems are devices or systems which, (a) are intended for surgical implant into the body, or (b) support or sustain life, and whose failure to perform, when properly used in accordance with instructions for use provided in the labeling, can be reasonably expected to result in a significant injury to the user.
2. A critical component is any component of a life support device or system whose failure to perform can be reasonably expected to cause the failure of the life support device or system, or to affect its safety or effectiveness.



**National Semiconductor Corporation**  
2900 Semiconductor Drive  
P.O. Box 58090  
Santa Clara, CA 95052-8090  
Tel: 1(800) 272-9959  
TWX: (910) 339-9240

**National Semiconductor GmbH**  
Livry-Gargan-Str. 10  
D-82256 Fürstenfeldbruck  
Germany  
Tel: (81-41) 35-0  
Telex: 527849  
Fax: (81-41) 35-1

**National Semiconductor Japan Ltd.**  
Sumitomo Chemical  
Engineering Center  
Bldg. 7F  
1-7-1, Nakase, Mihama-Ku  
Chiba-City,  
Chiba Prefecture 261  
Tel: (043) 299-2300  
Fax: (043) 299-2500

**National Semiconductor Hong Kong Ltd.**  
13th Floor, Straight Block,  
Ocean Centre, 5 Canton Rd.  
Tsimshatsui, Kowloon  
Hong Kong  
Tel: (852) 2737-1600  
Fax: (852) 2736-9960

**National Semicondutores Do Brazil Ltda.**  
Rue Deputado Lacorda Franco  
120-3A  
Sao Paulo-SP  
Brazil 05418-000  
Tel: (55-11) 212-5066  
Telex: 391-1131931 NSBR BR  
Fax: (55-11) 212-1181

**National Semiconductor (Australia) Pty. Ltd.**  
Building 16  
Business Park Drive  
Monash Business Park  
Nottingham, Melbourne  
Victoria 3168 Australia  
Tel: (3) 558-9999  
Fax: (3) 558-9998

National does not assume any responsibility for use of any circuitry described, no circuit patent licenses are implied and National reserves the right at any time without notice to change said circuitry and specifications.