

# "TP" & "QP" SERIES - Horizontal P.C. Mount Glass and Quartz Trimmer Capacitors

**FIG. 1**

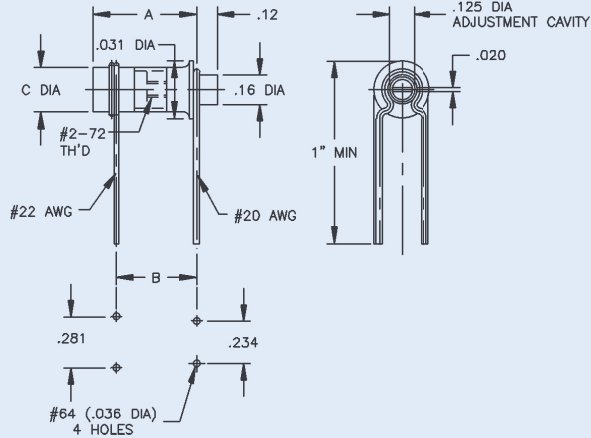

**FIG. 2**

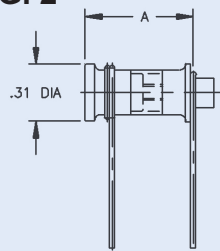

**FIG. 3**

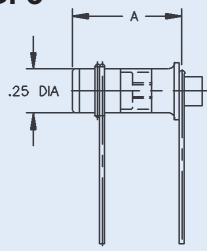

**FIG. 4**

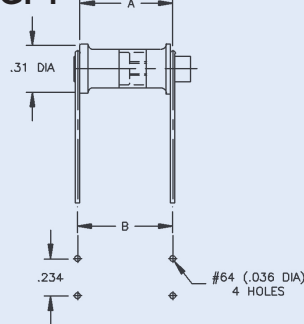

**NOTES:**

1. All Fig. 2 thru Fig. 4 parts have same end view as Fig. 1. Fig's 2 and 3 have mounting dimensions of Fig. 1.
2. C diameter of Fig. 1 parts .27 for embedded band and .25 on all other parts.

Detailed General Specifications on "Glass & Quartz General Specifications" page

IN	MM	IN	MM
0.005	0.13	0.92	23.37
0.020	0.51	0.97	24.64
0.03	0.76	1.00	25.40
0.036	0.91	1.02	25.91
0.040	1.02	1.03	26.16
0.045	1.14	1.05	26.67
0.06	1.52	1.08	27.43
0.08	2.08	1.09	27.69
0.12	3.05	1.13	28.70
0.125	3.18	1.14	28.96
0.14	3.56	1.16	29.46
0.16	4.06	1.17	29.73
0.17	4.32	1.19	30.23
0.234	5.94	1.33	33.78
0.25	6.35	1.38	35.05
0.27	6.86	1.42	36.07
0.28	7.11	1.47	37.34
0.281	7.14	1.52	38.61
0.31	7.87	1.61	40.89
0.33	8.38	1.64	41.66
0.35	8.89	1.67	42.42
0.36	9.14	1.69	42.93
0.38	9.65	1.73	43.94
0.39	9.91	1.75	44.45
0.41	10.41	1.92	48.77
0.42	10.67	1.95	49.53
0.44	11.18	1.98	50.29
0.45	11.43	2.03	51.56
0.47	11.94		
0.50	12.70		
0.56	14.22		
0.58	14.73		
0.60	15.24		
0.61	15.49		
0.63	16.00		
0.64	16.26		
0.67	17.02		
0.69	17.53		
0.70	17.78		
0.73	18.54		
0.77	19.56		
0.78	19.81		
0.83	21.08		
0.84	21.34		
0.88	22.35		
0.89	22.61		
0.91	23.11		

## Optional Configurations

**EXTENDED PLASTIC SHAFT**

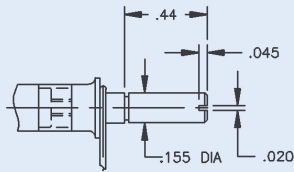

Add "EI" to Type Number  
(i.e. TP9CEI)

**EXTENDED METAL SHAFT**

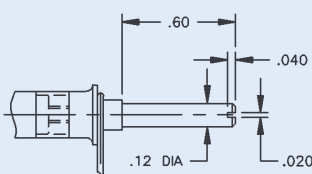

Add "E" to Type Number  
(i.e. TP9E)

**PRINTED CIRCUIT LUG**

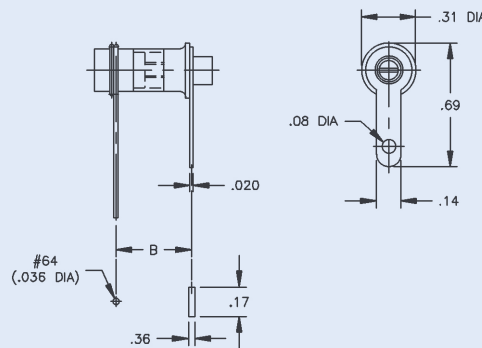

Add "L" to Type Number  
(i.e. TP28L)

# "TP" & "QP" SERIES - Horizontal P.C. Mount Glass and Quartz Trimmer Capacitors

## GLASS ANNULAR BAND

Capacitance Range (pF)		Q (Min.) 1 MHz	UNSEALED 750 DC Working Voltage (Fig. 1)				SEALED, METAL CAP, 750 DC Working Voltage (Fig. 2)			SEALED, GLASS END, 1,250 DC Working Voltage						
From Below	To Above		A±.03	B±.03	Type	MIL Designation	A±.03	B±.03	Type	SMALLER (Fig. 3)			LARGER MILL SIZE (Fig. 3)			
									A±.03	B±.03	Type	A±.06	B±.03	Type	MIL Designation	
0.8	4.5	650	.31	.25	TP5	PC41J4R5**	--	--	--	.39	.25	TP5G	.63	.50	TP5GA	PC42J4R5**
0.8	5.5	700	.31	.25	TP6	PC51J5R5	--	--	--	.39	.25	TP6G	.59	.50	TP6GA	PC52J5R5
0.8	8.5	650	.55	.44	TP9	PC41JIR5**	.58	.44	TP9C	.61	.44	TP9G	.88	.70	TP9GA	PC42J8R5**
1.0	11.0	700	.55	.44	TP11	PC51J110	.58	.44	TP11C	.61	.44	TP11G	.84	.70	TP11GA	PC52J110
0.8	12.0	650	.75	.63	TP12	PC41H120**	.78	.63	TP12C	.83	.63	TP12G	1.08	.84	TP12GA	PC42H120**
0.8	16.0	700	.75	.63	TP17	PC51H160	.78	.63	TP17C	.83	.63	TP17G	1.05	.84	TP17GA	PC52H160
0.8	18.0	650	1.00	.88	TP18	PC41H180**	1.05	.88	TP18C	1.08	.88	TP18G	1.33	1.02	TP18GA	PC42H180**
0.8	21.0	700	1.13	1.00	TP21	--	1.17	1.00	TP21C	--	--	TP21G	--	--	--	--
0.8	23.0	700	1.00	.88	TP23	PC51H230	1.05	.88	TP23C	1.08	.88	TP23G	1.30	1.02	TP23GA	PC52H230
0.8	30.0	650	1.59	1.38	TP30	PC41H300**	1.64	1.38	TP30C	1.67	1.38	TP30G	1.92	1.47	TP30GA	PC42H300**
0.8	38.0	700	1.59	1.38	TP38	PC51H380	1.64	1.38	TP38C	1.67	1.38	TP38G	1.89	1.47	TP38GA	PC52H380

## GLASS EMBEDDED BAND

Capacitance Range (pF)		Q (Min.) 1 MHz	UNSEALED 1,000 DC Working Voltage (Fig. 1)			SEALED, METAL CAP, 1,000 DC Working Voltage SMALLER (Fig. 4)			SEALED, METAL CAP 1,000 DC Working Voltage LARGER MILL SIZE (Fig. 4)			
From Below	To Above		A±.03	B±.06	Type	A±.03	B±.06	Type	A±.03	B±.06	Type	MIL Designation
2.0	10.0	800	.28	.25	TP10*	.35	.33	TP10C*	--	--	--	--
1.5	14.0	700	.39	.33	TP14	.45	.42	TP14C	.73	.69	TP14CA	--
1.2	16.0	800	.33	.28	TP15*	.41	.39	TP15C*	--	--	--	--
1.0	16.0	800	.39	.33	TP16	.45	.42	TP16C	.72	.69	TP16CA	PC43G160
2.0	25.0	800	.44	.36	TP25	.50	.47	TP25C	--	--	--	--
1.0	28.0	700	.63	.50	TP28	.70	.67	TP28C	.97	.92	TP28CA	--
1.0	36.0	800	.63	.50	TP36	.70	.67	TP36C	.97	.92	TP36CA	PC43G360
1.0	42.0	700	.84	.73	TP42	.91	.88	TP42C	1.19	1.14	TP42CA	--
1.0	52.0	800	.84	.73	TP52	.91	.88	TP52C	1.19	1.14	TP52CA	PC43G520
1.0	60.0	650	1.09	.91	TP60	1.16	1.13	TP60C	1.42	1.38	TP60CA	--
3.0	75.0	700	1.09	.91	TP75	1.16	1.13	TP75C	1.42	1.38	TP75CA	PC43G750
1.0	90.0	600	1.69	1.52	TP90	1.75	1.73	TP90C	2.03	1.98	TP90CA	--
1.0	120.0	600	1.69	1.52	TP120	1.75	1.73	TP120C	2.03	1.98	TP120CA	PC43G121
2.0	180.0	500	1.92	1.73	TP180*	1.98	1.95	TP180C*	--	--	--	--

## QUARTZ

Capacitance Range (pF)		Q (Min.) 1 MHz	UNSEALED, 750 DC Working Voltage (Fig. 1)				SEALED, QUARTZ END, 1,250 DC Working Voltage						
From Below	To Above		A±.03	B±.03	Type	MIL Designation	SMALLER (Fig. 3)			LARGER MILL SIZE (Fig. 3)			
						A±.03	B±.03	Type	A±.03	B±.06	Type	MIL Designation	
0.8	1.8	2000	.31	.25	QP2	PC41Q1R8	.38	.25	QP2G	.63	.50	QP2GA	PC42Q1R5
0.6	5.5	2000	.56	.44	QP6	PC41Q5R5	.64	.44	QP6G	.89	.70	QP6GA	PC42Q5R5
0.6	9.5	2000	1.00	.88	QP10	PC41Q9R5	1.09	.88	QP10G	1.33	1.02	QP10GA	PC42Q9R5
0.8	16.0	2000	1.61	1.38	QP16	PC41Q160	1.69	1.38	QP16G	1.92	1.47	QP16GA	PC42Q160

\*Parts Rated 500 DC Working Voltage

\*\*MIL-C-14409B parts not listed in MIL-C-14409D