



100Base-FX Integrated PHYceiver™

General Description

The ICS1889 is a fully integrated physical layer device supporting 100 Megabits per second CSMA/CD Fast Ethernet fiber optic applications. It is designed to support the requirements of DTEs (adapter cards), repeaters and switches. It is compliant with the ISO/IEC 8802 Fast Ethernet standard for 100Base-FX. It provides a Media Independent Interface (MII) allowing direct chip-to-chip connection, motherboard-to-daughter board connection or connection via a cable in a similar manner to the AUI approach used with 10Base-Tsystems. A station management interface is provided to receive command information and send status information. It transmits and receives NRZI data and interfaces directly to the optical transceiver. It can operate in either half duplex or full duplex.

Features

- One chip integrated physical layer
- All CMOS, low power design
- ISO/IEC 8802-3 CSMA/CD compliant
- 100Base-FX Half & Full Duplex
- Far end fault detection
- Media Independent Interface (MII)
- Station management interface
- Extended register set including QuickPoll™ detailed status monitoring
- Transmit clock synthesis
- Receive clock and data recovery
- Detailed receive error reporting
- Extended Test Modes
- 52-pin MQFP package with 2.0 mil body thickness

Block Diagram

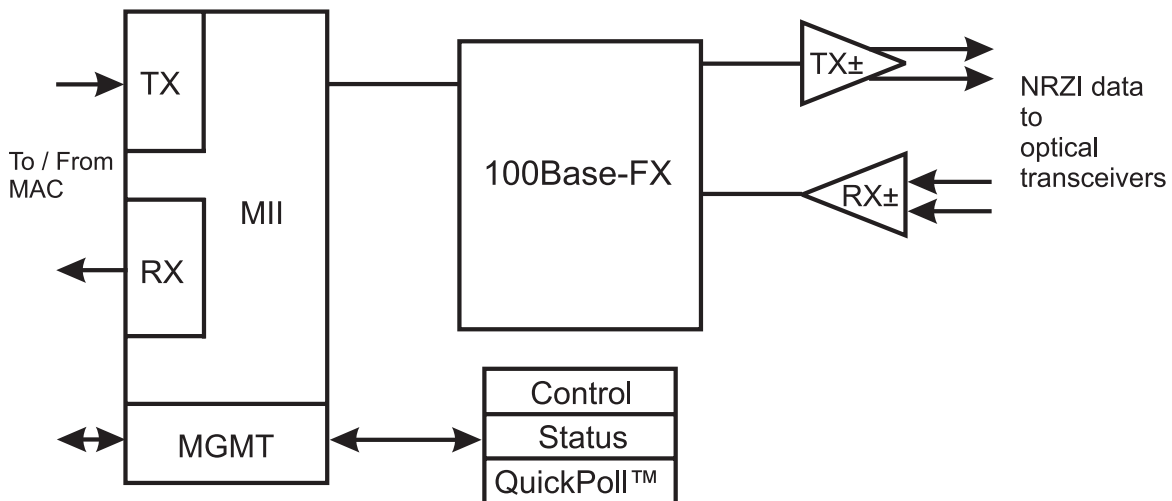



ICS1889

Block Diagram

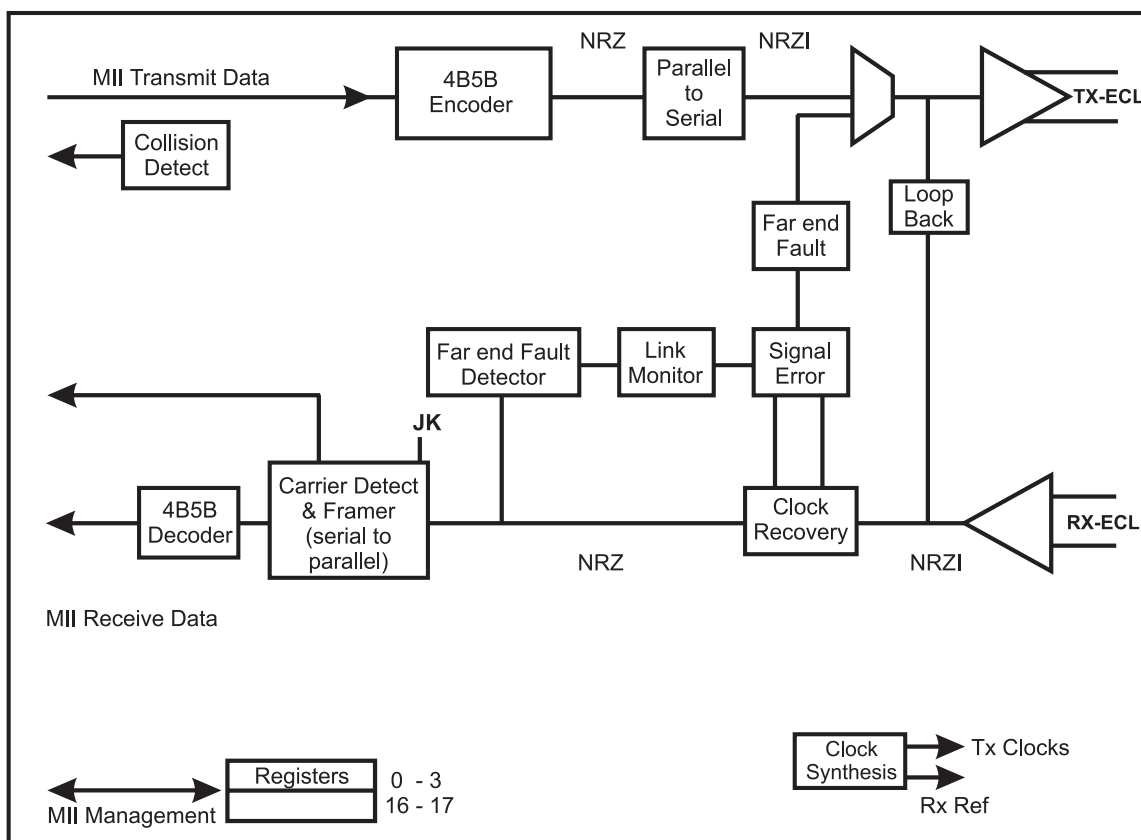

Functional Description

Introduction

The **ICS1889** is a nibble to bit stream and bit stream to nibble processor. When transmitting, it takes sequential nibbles presented at the Media Independent Interface (MII) and translates them to a serial bit stream for transmission on the media. When receiving, it takes the serial bit stream from the media and translates it to sequential nibbles for presentation to the MII. It has no knowledge of the underlying structure of the MAC frame it is conveying.

When transmitting, the **ICS1889** encapsulates the MAC frame (including the preamble) with the start-of-stream (SSD) and end-of-stream (ESD) delimiters. When receiving, it strips off the SSD and substitutes the normal preamble pattern and then presents this and subsequent preamble nibbles to the MII. When it encounters the ESD it ends the presentation of nibbles to the MII. Thus, the MAC reconciliation layer sees an exact copy of the transmitted frame.

During periods when no frames are being transmitted or received, there is a requirement to signal and detect the idle condition. This allows the higher levels to determine the integrity of the connection between the node and the hub. A continuous stream of ones is transmitted to signify the idle condition, the receive channel includes logic that monitors the IDLE data stream to look for this pattern and thereby establish the link integrity.

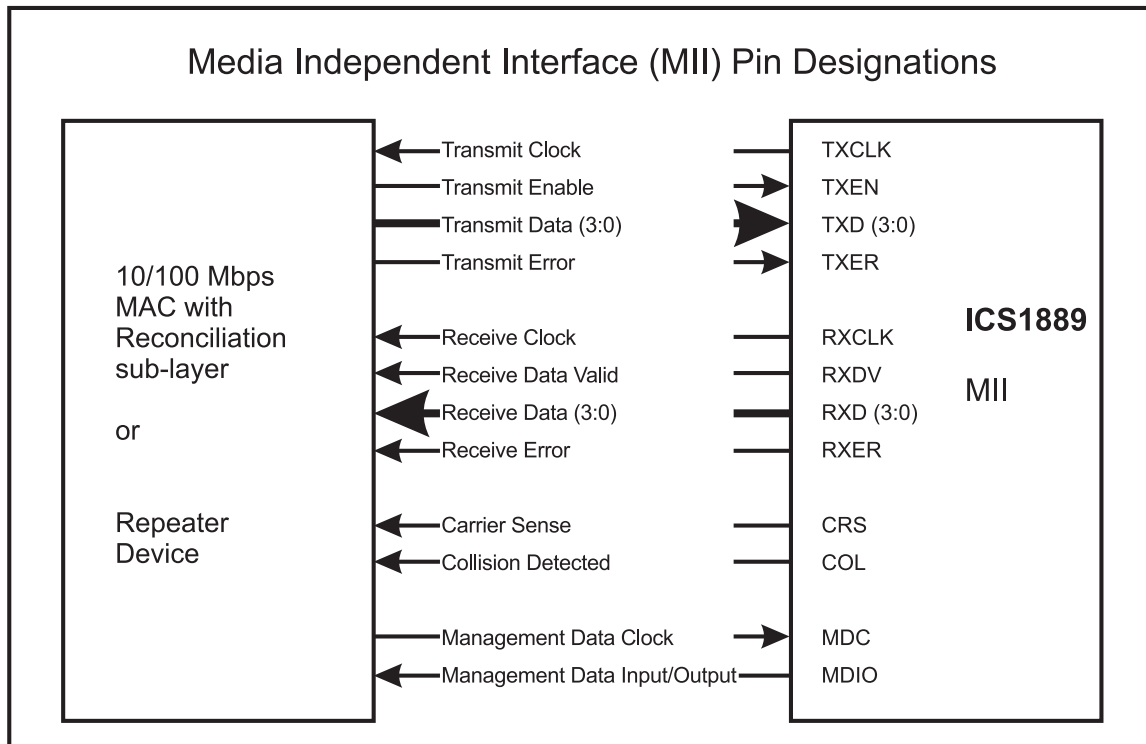

Media Independent Interface (MII)

The **ICS1889** implements a fully compliant IEEE 802.3 μ Media Independent Interface for connection to MACs or repeaters which allows connections between the **ICS1889** and MAC on the same board, motherboard/daughter board or via a cable in a similar manner to AUI connections.

The MII is a specification of signals and protocols which formalizes the interfacing of a 10/100 Mbps Ethernet Media Access Controller (MAC) to the underlying physical layer. The specification is such that different physical media may be supported (such as 100Base-TX, 100Base-T4 and 100Base-FX) transparently to the MAC.

The MII specifies transmit and receive data paths. Each path is 4-bits wide allowing for transmission of a nibble or single symbol. The transmit data path includes a transmit clock for synchronous transfer, a transmit enable signal and a transmit error signal. The receive data path includes a receive data

clock for synchronous transfer, a receive data valid signal and a receive error signal. Both the transmit clock and receive clock are sourced by the **ICS1889**. The **ICS1889** provides the MII signals carrier sense and collision detect. In half duplex mode, carrier sense indicates that data is being transmitted or received, and in full duplex mode it indicates that data is being received. Collision detect indicates that data has been received while a transmission is in progress.

The MII also specifies a two wire interface and a protocol between station management and the physical layer. The **ICS1889** implements this interface providing a bidirectional data line and a clock input for synchronizing the data transfers. This interface allows station management to read and write all of the **ICS1889** registers.

The **ICS1889** is designed to allow hot insertion of an MII cable into the MAC. During the power-up phase, the **ICS1889** will isolate the MII and the transmit pair by tristating the PHY outputs.



ICS1889

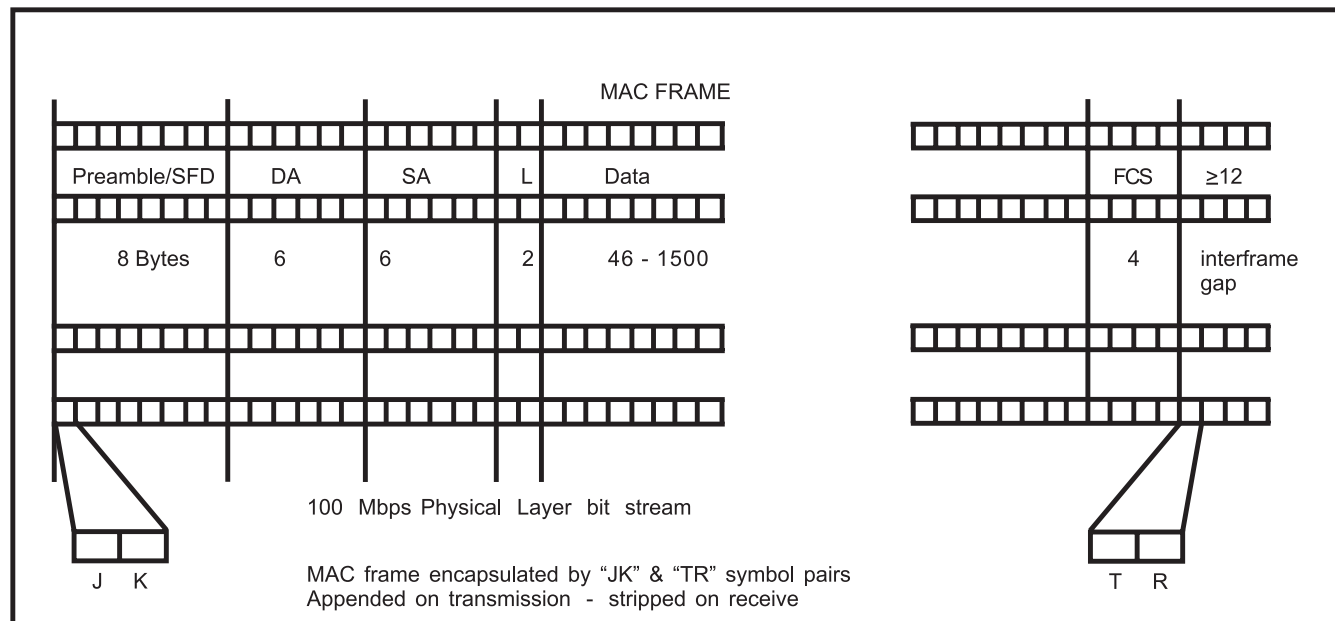

Transmit Clock Synthesizer

The **ICS1889** synthesizes the transmit clock using a PLL to produce 25 MHz and 125 MHz clocks. This allows the use of a low cost 25 MHz crystal or a low jitter reference frequency source.

Receive Clock Recovery

The receive clock recovery logic monitors the receive line and detects a "receive signal." The logic, which includes a PLL, extracts data and clock from the 100Base-FX, 125 Mbps, NRZI bit stream. In the event that the PLL is unable to lock on to the receive signal, it generates a "not locked signal." The transmit clock synthesizer provides a center frequency reference for operation of the clock recovery circuit in the absence of data. The "receive signal detected" and "not locked" signals are both used by the logic which monitors the receive channel for errors.

Carrier Detector & Framing

The carrier detector examines the receive serial bit stream looking for the SSD, the "JK" symbol pair. In the idle state, IDLE symbols (all logic ones) will be received. If the carrier detector detects a logic zero in the bit stream, it examines the following bits looking for the first two non-contiguous zeroes, confirms that the first 5-bits form the "J" symbol (11000) and asserts carrier detect. At this point the serial data is framed and the second symbol is checked to confirm the "K" symbol (10001). If successful, the following framed data (symbols) are presented to the 4B5B decoder. If the "JK" pair is not confirmed, the false carrier detect bit is asserted in the QuickPoll Register and the idle state is reentered.



4B/5B Encoder/Decoder

The **ICS1889** uses a 4B5B coding scheme. This maps a 4-bit nibble to a 5-bit code group called a symbol. Five bits allow 32 possible symbols, 16 are used for data encoding, 6 are used for control and 10 are not used and are invalid. The control symbols used are “JK” as the SSD, “TR” as the ESD, “I” as the IDLE symbol and “H” to signal an error. All other symbols are invalid and, if detected, will set the receive error bit in the status register, and cause the RXER signal to be asserted (see *Table 1* below).

When transmitting, nibbles from the MII are converted to a 5-bit code groups. During transmission, the first 16 nibbles obtained from the MII are the MAC frame preamble.

The **ICS1889** replaces the first two nibbles with the start-of-stream delimiter (the “JK” symbol pair). Following the last nibble, the **ICS1889** adds the end-of-stream delimiter (the “TR” symbol pair).

When receiving, 5-bit code groups are converted to nibbles and presented to the MII. If the **ICS1889** detects one or more invalid symbols, it sets the Invalid Symbol bit (17:7) in the QuickPoll Status Register. When receiving a frame, the first two 5-bit code groups received are the start-of-stream delimiter (the “JK” symbol pair), the **ICS1889** strips them and substitutes two nibbles of the normal preamble pattern. The last two 5-bit code groups are the end-of-stream delimiter (the “TR” symbol pair), these are stripped from the nibbles presented to the MAC.

Table 1: 4B5B Encoding

Symbol	Meaning	4B Code 3 2 1 0	5B Code 4 3 2 1 0	Symbol	Meaning	4B Code 3 2 1 0	5B Code 4 3 2 1 0
0	Data 0	0 0 0 0	1 1 1 1 0	8	Data 8	1 0 0 0	1 0 0 1 0
1	Data 1	0 0 0 1	0 1 0 0 1	9	Data 9	1 0 0 1	1 0 0 1 1
2	Data 2	0 0 1 0	1 0 1 0 0	A	Data A	1 0 1 0	1 0 1 1 0
3	Data 3	0 0 1 1	1 0 1 0 1	B	Data B	1 0 1 1	1 0 1 1 1
4	Data 4	0 1 0 0	0 1 0 1 0	C	Data C	1 1 0 0	1 1 0 1 0
5	Data 5	0 1 0 1	0 1 0 1 1	D	Data D	1 1 0 1	1 1 0 1 1
6	Data 6	0 1 1 0	0 1 1 1 0	E	Data E	1 1 1 0	1 1 1 0 0
7	Data 7	0 1 1 1	0 1 1 1 1	F	Data F	1 1 1 1	1 1 1 0 1
I	Idle	Undefined	1 1 1 1 1	V	Invalid	Undefined	0 0 0 1 0
J	SSD	0 1 0 1	1 1 0 0 0	V	Invalid	Undefined	0 0 0 1 1
K	SSD	0 1 0 1	1 0 0 0 1	V	Invalid	Undefined	0 0 1 0 1
T	ESD	Undefined	0 1 1 0 1	V	Invalid	Undefined	0 0 1 1 0
R	ESD	Undefined	0 0 1 1 1	V	Invalid	Undefined	0 1 0 0 0
H	Error	Undefined	0 0 1 0 0	V	Invalid	Undefined	0 1 1 0 0
V	Invalid	Undefined	0 0 0 0 0	V	Invalid	Undefined	1 0 0 0 0
V	Invalid	Undefined	0 0 0 0 1	V	Invalid	Undefined	1 1 0 0 1
Invalid Error Code Test TXER asserted							
I	Idle	1 1 1 1	1 1 1 1 1	V	Invalid	0 0 1 0	0 0 0 1 0
J	SSD	1 1 1 0	1 1 0 0 0	V	Invalid	0 0 1 1	0 0 0 1 1
K	SSD	1 0 1 1	1 0 0 0 1	V	Invalid	0 1 0 1	0 0 1 0 1
T	ESD	1 0 0 1	0 1 1 0 1	V	Invalid	0 1 1 0	0 0 1 1 0
R	ESD	0 1 1 1	0 0 1 1 1	V	Invalid	1 0 0 0	0 1 0 0 0
H	Error	0 1 0 0	0 0 1 0 0	V	Invalid	1 0 1 0	0 1 1 0 0
V	Invalid	0 0 0 0	0 0 0 0 0	V	Invalid	1 1 0 0	1 0 0 0 0
V	Invalid	0 0 0 1	0 0 0 0 1	V	Invalid	1 1 0 1	1 1 0 0 1

1. The IDLE symbol is sent continuously between frames.
2. J and K are the SSD and are always sent in pairs.
3. K always follows J.
4. T and R are the ESD and are always sent in pairs.
5. R always follows T.
6. A HALT symbol is used to signal an error condition.



ICS1889

Line Transmitter

The Line Transmitter output pair is a differential positive ECL (PECL) interface designed to connect directly to a standard fiber optic transceiver. The differential driver for the transmit signal is a programmable current source designed for resistive termination. Using an external resistor connected to the IPRG pin, the output current may be preset.

The differential driver for the TX± is current mode and is designed to drive resistive terminations in a complementary fashion. The output is current-sinking only, with the amount of sink current programmable via the IPRG1 pin. The sink current is equal to four times the IPRG1 current. For most applications, an 910Ω resistor from VDD to IPRG1 will set the current to the necessary precision.

The TX± pins are incapable for sourcing current, so V_{OH} must be set by the ratios of the Thevenin termination resistors for each of the lines. R1 is a pull-up resistor connected from the PECL output to VDD. R2 is a pull-down resistor connected from the PECL output to VSS. R1 and R2 are electrically in parallel from an AC standpoint. If we pick a target impedance of 50Ω for our transmission line impedance, a value of 62Ω for R1 and a value of 300Ω for R2 would yield a Thevenin equivalent characteristic impedance of 49.7Ω and a V_{OH} value of V_{DD} - .88 volts, compatible with PECL circuits.

To set a value for V_{OL}, we must determine a value for I_{prg} that will cause the output FET's to sink an appropriate current. We desire V_{OL} to be V_{DD} -1.81 or greater. Setting up a sink current of 19 milliamperes would guarantee this through our output termination resistors. As this is controlled by 4/1 current mirror, 4.75mA into I_{prg} should set this current properly. A 910Ω resistor from V_{DD} to I_{prg} should work fine.

Line Receiver

The Line Receiver is a differential input pair designed to interface directly to a standard fiber optic transceiver. It is a differential PECL input buffer.

Signal Error Detector

The ICS1889 Signal Error Detector is part of the clock recovery PLL. It detects a Receive Signal Error if no receive signal is received and detects a PLL Lock Error if the PLL is unable to lock on to the receive channel signal. A receive channel error is defined as the loss of receive signal or the loss of PLL lock.

Remote Fault Signaling

Remote fault signaling allows a node to indicate receive channel errors to its Link Partner using its transmit channel. When used by both nodes on a link segment, the integrity of both the transmit and receive channels can be verified.

Since 100Base-FX systems do not use auto-negotiation, an alternative, in-band signaling scheme is used to signal remote fault conditions. This scheme, Far End Fault Indication, relies on the characteristics of the quiescent state, (a continuous IDLE stream). The IDLE stream is a continuous stream of logic ones and a carrier is defined as the receipt of two noncontiguous logic zeroes. A Far End Fault is signaled with 84 logic ones followed by one logic zero, with the pattern repeated at least three times.

A Far End Fault will be signaled under three conditions; the first is when no activity is received from the Link Partner, since this can indicate a broken receive wire. The second is when the clock recovery circuit detects a Receive Signal Error or PLL Lock Error. The third is when a management entity sets the Transmit Far End Fault bit (16:3).

Far End Fault signaling continues until the condition causing the fault ceases.

Far End Fault Detection

The Far End Fault detector monitors the receive data serial bit stream looking for a repetitive pattern of 84 logic ones followed by a logic zero. Non-ICS1889 PHYs may have different definitions of what constitutes a remote fault. However, an ICS1889 will always respond to the in-band error signaling scheme. If the ICS1889 detects three consecutive patterns described above, it will signal a far end fault to the Link Monitor.

Link Monitor

If the Link Monitor receives a far end fault indication or a local receive channel error, it causes the ICS1889 to enter the IDLE mode, isolate the MII and assert the Link Status bit in the Status Register. Once the far end fault condition is de-asserted, the Link Monitor will return to the Link OK condition if the local receive channel is clear of errors. Once detected, a receive channel error signal will be indicated from 330 to 1000 microseconds.

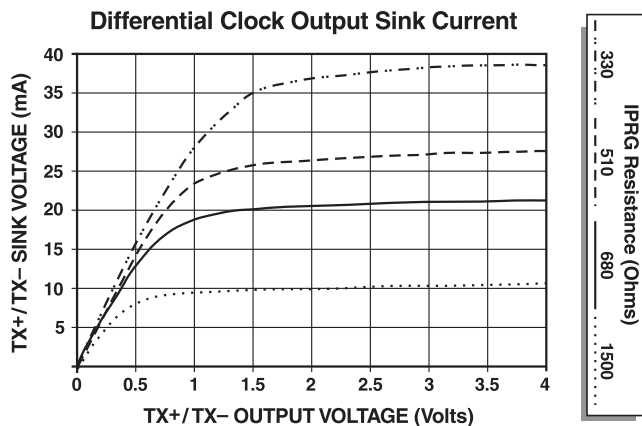



Management Interface

The **ICS1889** provides a management interface to connect to a management entity. The two wire serial interface is part of the MII and is described in the MII section. The interface allows the transport of status information from the **ICS1889** to the management entity and the transport of command words to the **ICS1889**. It includes a register set, a frame format, and a protocol.

Management Register Set

The register set includes the mandatory basic control and status registers and an extended set. The **ICS1889** implements the following registers.

Control	(register 0)
Status	(register 1)
PHY Identifier	(register 2)
PHY Identifier	(register 3)
Extended Control	(register 16)
QuickPoll Status	(register 17)

Management Frame Structure

The management interface uses a serial bit stream with a specified frame structure and protocol as defined below.

Preamble	11...11	(32 ones)
SOF	01	
Op Code	10 (read), 01 (write)	
Address	AAAAA	(5 bits)
Register	RRRRR	(5 bits)
TA	NN	(2 bits)
Data	DD...DD	(16 bits)
Idle	Zo	high impedance

Preamble

The **ICS1889** looks for a pattern of 32 logic ones followed by the SOF delimiter before responding to a transaction.

Start of Frame

Following the preamble a start of frame delimiter of zero-one initiates a transaction.

Operation Code

The valid codes are 10 for a read operation and 01 for a write operation. Other codes are ignored.

Address

There may be up to 32 PHYs attached to the MII. This 5 bit address is compared to the internal address of the **ICS1889**, as set by the P[0...4]* pins, for a match.

Register Address

The **ICS1889** uses this field to select one of the registers within the set. If a nonexistent register is specified, the **ICS1889** ignores the command.

TA

This 2-bit field is used by the **ICS1889** to avoid contention during read transactions. When writing to the **ICS1889**, the TA bits should be set to 10. When reading from the **ICS1889**, the device will tristate during this time.

Data

This is a 16-bit field with bit 15 being the first bit sent or received.

Idle

The **ICS1889** is in the high impedance state during the idle condition.

Register Access Rules

RO	–	Read Only, writes ignored
CW	–	Command Override Writable
RW/0	–	Read/Write only logic zero
RW	–	Read/Write

Four types of register access are supported by the device. Read Only (RO) bits may be read, but writes are ignored. Command Override Writable (CW) bits may be read, but writes are ignored unless preceded by writing a logic one to the Command Register Override bit (16:15). Read Write Zero (RW/0) bits may be read, but must only be written with a logic zero value. Writing a logic one to this type of bit may prevent the device from operating normally. Read Write (RW) bits may be read and may be written to any value.

Default Values

—	–	No default value
0	–	Default to logic zero
1	–	Default to logic one
Pin	–	Default depends on the state of the named pin

Modifier

SC	–	Self Clearing
LL	–	Latching Low
LH	–	Latching High

Self clearing bits will clear without any further writes after a specified amount of time. Latching bits are used to capture an event. To obtain the current status of a latching bit, the bit must be read twice in succession. If the special condition still persists, the bit will be the same on the second read; otherwise, the condition indication will not be present.



ICS1889

Control Register (register 0)

BIT	Function	Effect when bit = 0	Effect when bit = 1	Access	Default
15	Reset	No Effect	Reset PHY	RW/SC	0
14	Loop Back	Disable loop back mode	Enable loop back mode	RW	0
13	Data Rate	Always set to a logic one	100 Mbps operation	RO	1
12	Auto-Negotiate Enable	No Effect	Always set to logic zero	RO	0
11	Power-Down	Normal Mode	Reduced power consumption	RW	0
10	Isolate	No Effect	Isolate PHY from MII	RW	0 if PHY Address < >0, 1 if PHY Address=0
9	Restart Auto-Negotiation	No Effect	Always set to logic zero	RO	0
8	Duplex Mode	Half Duplex	Full Duplex	RW	0
7	Collision Test	No Effect	Enable collision signal test	RW	0
6	Reserved			RO	0
5	Reserved			RO	0
4	Reserved	If read, bits 0-6 and bits 9 and 12 will return logic zeroes and bit 13 will return a logic one.		RO	0
3				RO	0
2	Reserved	Writes to these bits will have no effect.		RO	0
1	Reserved			RO	0
0	Reserved			RO	0

Control Register (register 0)

The control register is a 16-bit read/write register used to set the basic configuration modes of the **ICS1889**. It is accessed through the management interface of the MII.

Reset (bit 15) default = 0

Setting this bit to a logic 1 will result in the **ICS1889** setting all its status and control registers to their default values. During this process the **ICS1889** may change internal states and the states of physical links attached to it. While in process, the bit will remain set and no other write commands to the control register will be accepted. The reset process will be completed within 500 ms and the bit will be cleared indicating that the reset process is complete.

Loop Back (bit 14)

Setting this bit to a logic one causes the **ICS1889** to tristate the transmit circuitry from sending data and the receive circuitry from receiving data. The collision detection circuitry is also disabled unless the collision test command bit is set. Data presented to the MII transmit data path is returned to the MII receive data path (see **ICS1889** Block Diagram, page 2).

Data Rate (bit 13)

This bit is permanently set to a logic one indicating that only the 100 Mbps mode is supported.

Auto-Negotiation Enable (bit 12)

This feature is not available with fiber optic solutions. This bit is permanently set to a logic zero indicating that it is not supported.

Power-Down (bit 11)

Setting it to logic one will cause the **ICS1889** to isolate its transmit data output and its MII interface with the exception of the management interface. The **ICS1889** will then enter a power-down mode where only the management interface and logic remain active. Setting this bit to logic zero after it has been set to a logic one will cause the **ICS1889** to power-up its logic and then reset all error conditions. It then enables transmit data and the MII interface. This process takes 500 ms to complete.



Isolate (bit 10)

Setting this bit to a logic one causes the **ICS1889** to isolate its data paths from the MII. In this mode, sourced signals (TXCLK, RXCLK, RXDV, RXER, RXD0-3, COL and CRS) are in a high impedance state and input signals (TXD0-3, TXEN and TXER) are ignored. The management interface is unaffected by this command.

When the PHY address is set to 0, the device will power-up in the isolated mode (bit 10=1). For all other addresses, the default will be bit 10=0.

Restart Auto-Negotiation (bit 9)

This feature is not available with fiber optic solutions. This bit is permanently set to a logic zero indicating that it is not supported.

Duplex Mode (bit 8)

Setting this bit to a logic one causes the **ICS1889** to operate in the full duplex mode and setting this bit to a logic zero causes it to operate in the half duplex mode. If the **ICS1889** is operating in loop back mode, this bit will have no effect on the operation.

Collision Test (bit 7)

This command bit is used to test that the collision circuitry is working when the **ICS1889** is operating in the loop back mode. Setting this bit to a logic one causes the **ICS1889** to assert the collision signal within 512 bit times of TXEN being asserted and to de-assert it within 4-bit times of TXEN being de-asserted. Setting this bit to a logic zero causes the **ICS1889** to operate in the normal mode.

Reserved (Bits 6 through 0)

These bits are reserved for future IEEE standards. When read, logic zeroes are returned. Writing has no effect on **ICS1889** operation.



ICS1889

Control Register (register 1)

BIT	Definition	When bit = 0	When bit = 1	Access	Default
15	OUI bit 19 s			CW	0
14	OUI bit 20 t			CW	1
13	OUI bit 21 u			CW	1
12	OUI bit 22 v			CW	0
11	OUI bit 23 w			CW	0
10	OUI bit 24 x			CW	0
9	Manufacturer's Model Number bit 5			CW	0
8	Manufacturer's Model Number bit 4			CW	0
7	Manufacturer's Model Number bit 3			CW	0
6	Manufacturer's Model Number bit 2			CW	0
5	Manufacturer's Model Number bit 1			CW	0
4	Manufacturer's Model Number bit 0			CW	1
3	Revision Number bit 3			CW	0
2	Revision Number bit 2			CW	1
1	Revision Number bit 1			CW	0
0	Revision Number bit 0			CW	1

Status Register (register 1)

The **ICS1889** status register is a 16 bit read only register used to indicate the basic status of the **ICS1889**. It is accessed via the management interface of the MII. It is initialized during a power-up or reset to predefined default values. If the **ICS1889** is enabled for auto-configuration, certain bits in the status register may be set to zero as defined below.

100Base-T4 (bit 15)

This bit is permanently set to a logic zero indicating that the **ICS1889** is not able to support 100Base-T4 operation.

100Base-X Full Duplex (bit 14)

This bit defaults to a logic one indicating that the **ICS1889** is able to support 100Base-X Full Duplex operation.

100Base-X Half Duplex (bit 13)

This bit defaults to a logic one indicating that the **ICS1889** is able to support 100Base-X Half Duplex operation.

10 Mbps Full Duplex (bit 12)

This bit is permanently set to a logic zero indicating that 10Base-T is not supported.

10 Mbps Half Duplex (bit 11)

This bit is permanently set to a logic zero indicating that 10Base-T is not supported.

Reserved (bits 10 through 6)

These bits are reserved for future IEEE standards. When read, logic zeroes are returned. Writing has no effect on **ICS1889** operation.

Auto-Negotiation Complete (bit 5)

This bit is permanently set to a logic zero.

Remote Fault (bit 4)

When set to a logic one, this bit indicates that a remote fault (Far End Fault) has been detected by the Link Monitor. This bit remains set to a logic one until it is cleared by reading the status register or by a reset command

If the link partner is implemented with a non-ICS1889 device, the causes of a link failure will be specified by that PHY vendor. If the link partner is implemented with an **ICS1889**, a remote fault indication means a receive channel error occurred.

Auto-Negotiation Ability (bit 3)

This feature is not available with fiber optic solutions. This bit is permanently set to a logic zero indicating that it is not supported.



Link Status (bit 2)

When set to a logic one, this bit indicates that the Link Monitor has established a valid link. If the Link Monitor detects a link failure, this bit is set to a logic zero and remains zero through the next read of the status register. A link failure may be due to an error in the receive channel or an error in the receive channel of the link partner (that is, a “remote fault”).

Jabber detect (bit 1)

This bit is permanently set to a logic zero.

Extended Capability (bit 0)

This bit is permanently set to a logic one indicating that the **ICS1889** has an extended register set.



PHY Identifier Register (register 2)

BIT	Definition	When bit = 0	When bit = 1	Access	Default
15	OUI bit 3 c			CW	0
14	OUI bit 4 d			CW	1
13	OUI bit 5 e			CW	1
12	OUI bit 6 f			CW	0
11	OUI bit 7 g			CW	0
10	OUI bit 8 h			CW	0
9	OUI bit 9 i			CW	0
8	OUI bit 10 j			CW	0
7	OUI bit 11 k			CW	0
6	OUI bit 12 l			CW	0
5	OUI bit 13 m			CW	0
4	OUI bit 14 n			CW	1
3	OUI bit 15 o			CW	0
2	OUI bit 16 p			CW	1
1	OUI bit 17 q			CW	0
0	OUI bit 18 r			CW	1

PHY Identifier Register (register 2)

Register 2 and Register 3 contain the 24-bit Organizationally Unique Identifier (OUI), Manufacturers Model Number and Revision Number. Integrated Circuit Systems’s OUI is used as the default for registers 2 and 3. These values may be overridden using the Command Override bit (16:15).

Organizationally Unique Identifier bits 3-18(bits 15-0)

This field contains the lowest 16 bits of the IEEE OUI excluding bits 0, 1, and 2. Bit 3 of the OUI maps to bit 15 of the register.

OUI Formatting Information

The ICS OUI is shown below with information on mapping the OUI value into registers 2 and 3.

Octet Format:

```

00      A0      BE
|        |      |
|        |      | Third octet
|        |      |
|        |      | Second octet
First octet
    
```

Binary Format:

```

      0      0      0      A      E      B
0000 0000 0000 0101 0111 1101
|      |      |      |      |      |
l s b  m s b  l s b  m s b  l s b  m s b
( I / G )
    
```

IEEE Standard 802 Lettered Format

```

0000 0000 0000 0101 0111 1101
abcd  efgh  ijkl  mnop qrst  uvwx
    
```

Model and Revision Information

Model	Part
1	ICS1889
2	ICS1890

The revision number will be incremented each time the silicon is significantly revised.

These two registers can always be read and may be written by setting the Command Override bit in the Configuration register (16:15) and then performing a write operation. At power-up and reset they are set to Integrated Circuit Systems’s OUI. By allowing these registers to be written, a systems vendor may substitute their own OUI.



PHY Identifier Register (register 3)

BIT	Definition	When bit = 0	When bit = 1	Access	Default
15	OUI bit 19 s			CW	0
14	OUI bit 20 t			CW	1
13	OUI bit 21 u			CW	1
12	OUI bit 22 v			CW	0
11	OUI bit 23 w			CW	0
10	OUI bit 24 x			CW	0
9	Manufacturer's Model Number bit 5			CW	0
8	Manufacturer's Model Number bit 4			CW	0
7	Manufacturer's Model Number bit 3			CW	0
6	Manufacturer's Model Number bit 2			CW	0
5	Manufacturer's Model Number bit 1			CW	0
4	Manufacturer's Model Number bit 0			CW	1
3	Revision Number bit 3			CW	0
2	Revision Number bit 2			CW	1
1	Revision Number bit 1			CW	0
0	Revision Number bit 0			CW	1

PHY Identifier Register (register 3)

Register 2 and Register 3 contain the 24 bit Organizationally Unique Identifier (OUI), Manufacturers Model Number and Revision Number. Integrated Circuit Systems's OUI is used as the default for registers 2 and 3.

These two registers can always be read and may be written by setting the Command Override bit in the Configuration register (16:15) and then performing a write operation. At power-up and reset they are set to Integrated Circuit Systems' OUI. By allowing these registers to be written, a systems vendor may substitute their own OUI.

See register 2 for OUI formatting information.

Organizationally Unique Identifier bits 19-24 (bits 15-10)

This field contains the upper 6 bits of the IEEE OUI. Bit 19 of the OUI maps to bit 15 of the register.

Manufacturer's Model Number bits 5-0 (bits 9-4)

Model	Part
1	ICS1889
2	ICS1890

Revision Number bits 3-0 (bits 3-0)

The revision number will be incremented each time the silicon is significantly revised. Currently the device is at revision 1.



Extended Control Register (register 16)

BIT	Definition	When bit = 0	When bit = 1	Access	Default
15	Command Register Override	Don't allow write	Allow write	RW	0
14	Reserved for ICS	Write logic zero. Read unspecified.		RW/0	—
13	Reserved for ICS	Write logic zero. Read unspecified.		RW/0	—
12	Reserved for ICS	Write logic zero. Read unspecified.		RW/0	—
11	Reserved for ICS	Write logic zero. Read unspecified.		RW/0	—
10	PHY address - S4			CW	P4RD
9	PHY address - S3	MII management		CW	P3TD
8	PHY address - S2	Register address code		CW	P2LI
7	PHY address - S1	0 - 31 Read Only		CW	P1CL
6	PHY address - S0			CW	P0FD
5	Reserved for ICS	Write logic zero. Read unspecified.		RW/0	—
4	Far End Fault	Disabled	Enabled	RW	1
3	Transmit Far End Fault	No fault transmitted	Fault transmitted	RW	0
2	Invalid Error Code Test	Disabled	Enabled	RW	0
1	Reserved for ICS	Write logic zero. Read unspecified.		RW/0	—
0	Reserved for ICS	Write logic zero. Read unspecified.		RW/0	—

Extended Control Register (register 16)

The Extended Control Register is a 16-bit read write register used to pre-program the **ICS1889**. At power-up and reset, this register will be loaded to the default values specified. It may subsequently be read or written. If written, the result is bit dependent as discussed below.

Command Register Override (bit 15)

If set to a logic one, this bit allows a subsequent write to the Status Register (register 1) and the PHY identifier registers 2 and 3. The contents of registers 2 and 3 may be set to any value. The Status Register may have certain specified bits set or reset. The first write to registers 1, 2 or 3 after this bit is set will reset it preventing subsequent writes from having any effect.

Reserved (bit 14)

This bit is reserved for ICS use. It must always be written with a logic zero. The value of this bit when read is unspecified and may be a logic zero or one.

Reserved (bit 13)

This bit is reserved for ICS use. It must always be written with a logic zero. The value of this bit, when read, is unspecified and may be a logic zero or one.

Reserved (bit 12)

This bit is reserved for ICS use. It must always be written with a logic zero. The value of this bit when read is unspecified and may be a logic zero or one.

Reserved (bit 11)

This bit is reserved for ICS use. It must always be written with a logic zero. The value of this bit when read is unspecified and may be a logic zero or one.

PHY Address (Bits 10 through 6)

These 5 bits are used to indicate the address of the **ICS1889** on the management port of the MII (any number in the range 0 - 31). A read returns the address. Extra care should be taken if a command override write is performed on these bits, as a change in the PHY address must be accounted for by the device reading and writing to the MII Management interface.

Reserved (bit 5)

This bit is reserved for ICS use. It must always be written with a logic zero. The value of this bit when read is unspecified and may be a logic zero or one.



Enable Far End Fault (bit 4)

If this bit is set to a logic one, the far end fault logic becomes active resulting in faults being signaled and recognized via the “in-band” signaling scheme. If this bit is set to a logic zero, the far end fault logic is disabled.

Transmit Far End Fault (bit 3)

Management may indicate a fault has occurred to its link partner by setting this bit to a logic one. Indicating a fault brings the link down and disables the reception of data until this bit is cleared and the link is reestablished.

Invalid Error Code Test (bit 2)

If this bit is set to a logic one, the 4B5B encoder operates as a 5B5B encoder obtaining the fifth bit of the code group from the value of TXER.

Reserved (bit 1)

This bit is reserved for ICS use. It must always be written with a logic zero. A read always returns a logic zero.

Reserved (bit 0)

This bit is reserved for ICS use. It must always be written with a logic zero. A read always returns a logic zero.



QuickPoll Status Register (register 17)

BIT	Definition	When bit = 0	When bit = 1	Access	Default
15	Data Rate	Always a logic one	100 Mbps selected	RO	1
14	Duplex	Half duplex selected	Full duplex selected	RO	0 if PRIO=1 or DPEN if PRIO=0
13	Reserved for ICS	Read unspecified		RO	—
12	Reserved for ICS	Read unspecified		RO	—
11	Reserved for ICS	Read unspecified		RO	—
10	Receive Signal Error	Signal	Loss of signal	RO/LH	0
9	PLL Lock Error	PLL locked	PLL failed to lock	RO/LH	0
8	False Carrier Detect	Normal carrier or idle	False carrier detected	RO/LH	0
7	Invalid Symbol	Valid symbols	Invalid symbol detected	RO/LH	0
6	Halt Symbol	Normal symbols	HALT symbol detected	RO/LH	0
5	Premature End	Normal stream	Stream with two IDLES	RO/LH	0
4	Reserved for ICS	Read unspecified		RO	—
3	Reserved for ICS	Read unspecified		RO	—
2	Priority Pin State	Hardware	Software	RO	PRIO
1	Remote Fault	No remote fault detected	Remote fault detected	RO/LH	0
0	Link Status	Link is not valid	Link is valid	RO/LL	0

QuickPoll Status Register (register 17)

The QuickPoll status register is a 16-bit read only register used to indicate the comprehensive status of the ICS1889. All register status bits that might need to be repetitively examined at run time are located in this register, even though some bits duplicate functionality from other registers. This allows the device status to be rapidly obtained with a single register access.

The register is accessed via the management interface of the MII. It can always be read and may be written by setting the override bit in the Configuration Register (register 16, bit 15) and then performing a write operation. It is initialized during a power-up or reset to predefined default values.



Data Rate (bit 15)

This bit is permanently set to a logic one indicating it only operates at 100 Mbps.

Duplex (bit 14)

If set to a logic one, this bit indicates that the full duplex mode has been selected. If set to a logic zero, it indicates that the half duplex mode has been selected. It is initialized to logic zero.

Reserved (bit 13)

This bit is reserved for ICS use. The value of this bit is unspecified and may be a logic zero or one.

Reserved (bit 12)

This bit is reserved for ICS use. The value of this bit is unspecified and may be a logic zero or one.

Reserved (bit 11)

This bit is reserved for ICS use. The value of this bit is unspecified and may be a logic zero or one.

Receive Signal Error (bit 10)

If set to a logic one, the Receive Signal error bit indicates that the **ICS1889** read channel has at some point been unable to detect the receive channel signal. This bit will remain set until cleared by reading the contents of register 17. It is initialized to logic zero.

PLL Lock Error (bit 9)

If set to a logic one, the loss of PLL lock (bit 9) indicates that the **ICS1889** read channel PLL has failed to lock on to the read channel signal. This bit will remain set until cleared by reading the contents of register 17. It is initialized to logic zero.

False Carrier (bit 8)

If set to a logic one, the false carrier (bit 8) indicates that the **ICS1889** has detected a false carrier sometime since this bit was last reset. This bit will remain set until cleared by reading the contents of register 17. It is initialized to logic zero.

Invalid Symbol (bit 7)

If set to a logic one, the invalid symbol (bit 7) indicates that an invalid symbol has been detected in a received frame since the bit was last reset. This bit will remain set until cleared by reading the contents of register 17. It is initialized to logic zero.

Halt Symbol (bit 6)

If set to a logic one, the halt symbol (bit 6) indicates that the **ICS1889** has detected the halt symbol in a frame since bit 11 was last reset. This bit will remain set until cleared by reading the contents of register 17. It is initialized to logic zero.

Premature End (bit 5)

This bit is normally a logic zero indicating normal data streams. If two IDLE symbols are detected during the reception of a receive data stream, this bit is set to a logic one and the **ICS1889** returns to the idle state. This bit is initialized to a logic zero.

Reserved (bit 4)

This bit is reserved for ICS use. The value of this bit is unspecified and may be a logic zero or one.

Reserved (bit 3)

This bit is reserved for ICS use. The value of this bit is unspecified and may be a logic zero or one.

Priority Pin State (bit 2)

This bit reflects the setting of the Priority Pin (pin 17). When this bit is a logic zero, duplex mode is controlled by the Duplex Enable pin (pin 18). When this bit is a logic one, duplex mode is controlled by the Duplex Mode bit (0:8).

Remote Fault (bit 1)

This is a copy of the Remote Fault bit of the Status Register (register 1).

Link Status (bit 0)

This is a copy of the Link Status bit of the Status Register (register 1).



Pin Definitions

Signal	Meaning	Signal	Meaning
TXCLK	Transmit Clock	TX+	Transmitted data positive
TXEN	Transmit Enable	TX-	Transmitted Data negative
TXD3	Transmit Data 3	IPRG	Current program
TXD2	Transmit Data 2	RX+	Receive Data positive
TXD1	Transmit Data 1	RX-	Receive Data negative
TXD0	Transmit Data 0	REF+	Frequency reference
TXER	Transmit Error	REF-	Frequency reference
RXCLK	Receive Clock	SD+	Signal Detect
RXDV	Receive Data Valid	SD-	Signal Detect
RXD3	Receive Data 3		
RXD2	Receive Data 2	SYSR	System reset
RXD1	Receive Data 1	PRIO	Priority
RXD0	Receive Data 0	DPEN	Duplex Enable
RXER	Receive Error	LSTA	Link Status
CRS	Carrier Sense	P4RD	Receive data LED
COL	Collision Detect	P3TD	Transmit data LED
		P2LI	Link Integrity LED
MDC	Management Data Clock	P1CL	Collision detect LED
MDIO	Management Data Input/Output	P0FD	Full duplex LED
		NOD/REP	Node or Repeater Mode Selection

MII Interface Pin Descriptions

Transmit Clock TXCLK

The Transmit Clock (TXCLK) is a continuous clock signal generated by the **ICS1889** to synchronize the Transmit Enable, Transmit Data and Transmit Error lines. The **ICS1889** clock frequency is 25% of the nominal transmit data rate. At 100 Mbps its frequency is 25 MHz. The TXCLK clock duty cycle is in the range 35% to 65%.

Transmit Enable TXEN

Transmit Enable (TXEN) indicates to the **ICS1889** that the MAC is sending valid data nibbles for transmission on the physical media. Synchronous with its assertion the **ICS1889** will begin reading the data nibbles on the transmit data lines. It is the responsibility of the MAC to order the nibbles so that the preamble is sent first, followed by destination, source, length, data and CFS fields since the **ICS1889** has no knowledge of the frame structure and is merely a “nibble” processor. The **ICS1889** terminates transmission of nibbles following the deassertion of Transmit Enable (TXEN).

Transmit Data 3 TXD3

Transmit Data 3 (TXD3) is the most significant bit of the transmit data nibble. TXD3 is sampled by the **ICS1889** synchronously with the Transmit Data Clock when TXEN is asserted. When TXEN is de-asserted the **ICS1889** is unaffected by the state of TXD3

Transmit Data 2 TXD2

Transmit Data 2 (TXD2) is sampled by the **ICS1889** synchronously with the Transmit Data Clock when TXEN is asserted. When TXEN is de-asserted the **ICS1889** is unaffected by the state of TXD2.

Transmit Data 1 TXD1

Transmit Data 1 (TXD1) is sampled by the **ICS1889** synchronously with the Transmit Data Clock when TXEN is asserted. When TXEN is de-asserted the **ICS1889** is unaffected by the state of TXD1.



Transmit Data 0 TXD0

Transmit Data 0 (TXD0) is the least significant bit of the transmit data nibble. TXD0 is sampled by the **ICS1889** synchronously with the Transmit Data Clock when TXEN is asserted. When TXEN is de-asserted the **ICS1889** is unaffected by the state of TXD0.

Transmit Error TXER

The assertion of Transmit Error (TXER) for one or more clock periods will cause the **ICS1889** to emit one or more HALT symbols. The signal is synchronous with TXCLK. In the normal operating mode, a HALT symbol will be substituted for the next nibble encoded. If the invalid error code test bit in the Configuration Register is set (register 16, bit 2), TXER becomes an additional input to the 4B5B encoder. This allows the **ICS1889** to send the full set of 32 symbols including the invalid symbols. Table 1 shows the modified 4B5B encoding in the test mode. A timing diagram for TXER is shown in Figure xxx.

Receive Clock RXCLK

The Receive Clock (RXCLK) is sourced by the **ICS1889**. There are two possible sources for the Receive Clock (RXCLK). When a carrier is present on the receive pair, the source is the recovered clock from the data stream. When no carrier is present on the receive pair, the source is synchronized to the transmit PLL. The IDLE symbol is sent during periods of inactivity and the Recovered clock will be selected.

The **ICS1889** will only switch between clock sources when Receive Data Valid (RXDV) is de-asserted. During the period between Carrier Sense (CRS) being asserted and Receive Data Valid being asserted, a clock phase change of up to 360 degrees may occur. Following the de-assertion of Receive Data Valid a clock phase of 360 degrees may occur.

When Receive Data Valid is asserted, the Receive Clock frequency is 25% of the data rate, 25 MHz. The minimum low and high times of the clock are guaranteed to be 35% under all conditions and the duty cycle between 35% and 65% except during the clock transition conditions specified above. The **ICS1889** synchronizes Receive Data Valid, Received Data and Receive Error with Receive Clock (RXCLK).

Receive Data Valid RXDV

Receive Data Valid (RXDV) is generated by the **ICS1889**. It indicates that the **ICS1889** is recovering and decoding data nibbles on the Receive Data (RXD) data lines synchronous with the Receive Data Clock (RXCLK). It is the responsibility of the MAC to assemble nibbles into MAC frames since the **ICS1889** has no knowledge of the frame structure and is merely a “nibble” processor. The **ICS1889** asserts RXDV when it detects a start of stream delimiter (SSD) and de-asserts it following the last data nibble or upon detection of a signal error. RXDV is synchronous with the Receive Data Clock (RXCLK).

Receive Data RXD3

Receive Data 3 (RXD3) is the most significant bit of the receive data nibble. RXD is sourced by the **ICS1889**. When Receive Data Valid (RXDV) is asserted by the **ICS1889**, it will transfer the fourth bit of the symbol synchronously with Receive Clock (RXCLK).

Receive Data RXD2

Receive Data 2 (RXD2) is sourced by the **ICS1889**. When Receive Data Valid (RXDV) is asserted by the **ICS1889**, it will transfer the third bit of the symbol synchronously with Receive Clock (RXCLK).

Receive Data RXD1

Receive Data 1 (RXD1) is sourced by the **ICS1889**. When Receive Data Valid (RXDV) is asserted by the **ICS1889**, it will transfer the second bit of the symbol synchronously with Receive Clock (RXCLK).

Receive Data RXD0

Receive Data 0 (RXD0) is the least significant bit of the receive data nibble. RXD0 is sourced by the **ICS1889**. When Receive Data Valid (RXDV) is asserted by the **ICS1889**, it will transfer the first bit of the symbol synchronously with Receive Clock (RXCLK).



ICS1889

Receive Error (RXER)

The **ICS1889** detects two types of receive errors, errors occurring during the reception of valid frames and an error condition known as false carrier detect. False carrier detect is signaled so that repeater applications can prevent the propagation of false carrier detection. RXER always transitions synchronously with RXCLK.

The assertion of Receive Error (RXER) for one or more clock periods during the period when RXDV is asserted (receiving a frame) indicates that the **ICS1889** has detected a read channel error. There are three sources of read channel error: loss of receive signal, failure of the PLL to lock and invalid symbol detection (including the HALT symbol). Timing diagram xxx (RXER Timing Diagram) shows the relationship of RXER to RXCLK, RXEN and receive channel error conditions.

RXER may also be asserted when RXDV is de-asserted. The **ICS1889** will assert RXER and set RXD(3:0) to 1110 if a false carrier is detected. For a good carrier to be detected, the **ICS1889** looks continuously at the incoming IDLE stream (1111...) for two non-contiguous logic zeros and then checks for the SSD of "JK." In the event that two non-contiguous logic zeroes are detected but the JK symbol pair is not, then a false carrier condition is signaled and the IDLE condition is reentered.

Carrier Sense (CRS)

The **ICS1889** asserts Carrier Sense (CRS) when it detects that receive channel is non-idle in the full duplex mode or when it detects that either the receive or transmit channels are non-idle in the half duplex mode. A receive channel non-idle condition is detected by two non-contiguous zeros in any 10 bits ("IJ"). CRS is not synchronous to either the transmit or receive clocks.

Collision Detected (COL)

The **ICS1889** asserts Collision Detected (COL) when it detects a receive carrier (non-idle) condition while transmitting (TXEN asserted) in the half duplex mode. The COL is not synchronous to either the transmit or receive clocks. In full duplex mode, collision will be disabled.

Management Data Clock (MDC)

The Management Data Clock (MDC) is used by the **ICS1889** to synchronize the transfer of management information to or from the **ICS1889**. The **ICS1889** requires minimum high and low times of 160 ns and a minimum clock period of 400 ns.

Management Data Input/Output

The Management Data Input/Output (MDIO) is a tristate line driven by station management to transfer command information or driven by the **ICS1889** to transfer status information. All transfers and sampling are synchronous with MDC. If the **ICS1889** is to be used in an application which uses the mechanical MII specification, MDIO must have a pull-up at the **ICS1889** end and a pull-down at the station management end. This enables station management to determine if the connection is intact.

Transmit and Receive Pin Descriptions

Transmit Pair (TX+ & TX-)

The Transmit pair TX+ and TX- carries the NRZI serial bit stream for conversion to optical signals.

Receive Pair (RX+ & RX-)

The Receive pair RX+ and RX- carries the NRZI serial bit stream from the optical converter.

Transmit Current Program (IPRG)

This pin is connected to a resistor and sets the current drive of the transmitter.

Frequency Reference (REF_IN and REF_OUT)

A 25 MHz crystal oscillator or reference source should be fed into the REF_IN input, while leaving REF-OUT not connected.

Signal Detect (SD+ & SD-)

This PECL input pair provides a signal detect indication from the optical transceiver. The **ICS1889** will indicate a receive channel error if this signal is de-asserted. A receive channel error is also indicated if either a PLL lock error or a receive signal error is detected.



Initialization & LED Pin Descriptions

A set of five pins is dual purpose. At power-up and reset they define the MII PHY address of this **ICS1889**. Subsequent to power-up and reset, they become LED status indicators. The five pins are used to set the PHY address by connecting them to Vss to indicate a logic one and ground to indicate a logic zero. They must be connected to either Vss or ground using an LED (see Figure xxx). At power-up or reset, the **ICS1889** will determine whether the pin is tied to ground or Vss and set the appropriate value in the configuration register. It will then determine the polarity of the signal required to drive the LED and enter the status indicating mode. It will stay in this state until a reset occurs.

PHY Address 4 - Receive Data LED (P4RD)

At power-up and reset this pin is sampled for a logic high or zero. If a logic one is detected, a value of 16 is set in the configuration register.

The **ICS1889** sets this bit to the appropriate value to turn on the LED when receive data is detected. This signal is sticky and will ensure that a single packet will be seen. If the packet stream is continuous, the LED will appear permanently on.

PHY Address 3 - Transmit Data LED (P3TD)

At power-up and reset this pin is sampled for a logic high or zero. If a logic one is detected, a value of 8 is set in the configuration register.

The **ICS1889** sets this bit to the appropriate value to turn on the LED when transmit data is detected. This signal is sticky and will ensure that a single packet will be seen. If the packet stream is continuous, the LED will appear permanently on.

PHY Address 2 - Link Integrity LED (P2LI)

At power-up and reset this pin is sampled for a logic high or zero. If a logic one is detected, a value of 4 is set in the configuration register.

The **ICS1889** sets this bit to the appropriate value to turn on the LED when the Link Integrity status is OK.

PHY Address 1 - Collision LED (P1CL)

At power-up and reset this pin is sampled for a logic high or zero. If a logic one is detected, a value of 2 is set in the configuration register.

The **ICS1889** sets this bit to the appropriate value to turn on the LED when a collision is detected. This signal is sticky and will ensure that a single collision will be seen. If the collisions are continuous, the LED will appear permanently on.

PHY Address 0 - Full Duplex LED (P0FD)

At power-up and reset this pin is sampled for a logic high or zero. If a logic one is detected, a value of 1 is set in the configuration register.

The **ICS1889** sets this bit to the appropriate value to turn on the LED when the Full Duplex mode is selected.

Priority (PRIO)

When connected to ground, this pin enables the Duplex Enable Pin (DPEN) to select the duplex mode. When this pin is high, DPEN becomes an output indicating the duplex mode selected.

Duplex Enable (DPEN)

If the Priority pin (PRIO) is high, Duplex Enable (DPEN) is an output indicating the selected duplex mode. A logic one indicates full duplex and a logic zero indicates half duplex. If the Priority Pin is grounded, this pin becomes an input that sets the duplex mode, a logic one setting the full duplex mode and a logic zero setting the half duplex mode.

Link Status (LSTA)

This signal indicates the status of the link monitor. A logic one indicates that the link integrity is OK.

System Reset (SYSR)

When grounded for more than 80ns, this pin causes the **ICS1889** to enter a reset cycle. Upon completion of a reset, the **ICS1889** will be initialized to the same state as that following a power-up cycle. If SYSR is held low, the **ICS1889** remains in the reset state.

Node/Repeater (NOD/REP)

When this input is logic zero, the device will default to Node operation. SQE test will default to on.

When this input is logic one, the device will default to Repeater operation. SQE test will default to off and Carrier Sense will be determined by receive activity only.

The NOD/REP pin does not have a default configuration and must be tied either to ground or supply.



ICS1889

Packaging

Pin Assignments

PIN	Signal	Meaning	PIN	Signal	Meaning
1	VDD	VDD (LEDs)	27	RXD1	Receive Data 1
2	NOD/REP	Node or Repeater Mode Selection	28	RXD0	Receive Data 0
3	TX-	Transmitted Data negative	29	RXDV	Receive Data Valid
4	TX+	Transmitted Data positive	30	RXCLK	Receive Clock
5	IPRG	Current program	31	RXER	Receive Error
6	VSS	VSS (Transmit Data)	32	VSS	VSS (MII I/O)
7	VSS	VSS	33	VDD	VDD (MII I/O)
8	RX+	Receive Data positive	34	TXER	Transmit Error
9	RX-	Receive Data negative	35	TXCLK	Transmit Clock
10	SD+	Signal Detect	36	TXEN	Transmit Enable
11	SD-	Signal Detect	37	TXD0	Transmit Data 0
12	N/C	No Connect	38	TXD1	Transmit Data 1
13	N/C	No Connect	39	TXD2	Transmit Data 2
14	VDD	VDD (Receive)	40	TXD3	Transmit Data 3
15	LSTA	Link Status	41	COL	Collision Detect
16	SYSR	System reset	42	CRS	Carrier Sense
17	PRI0	Priority	43	VSS	VSS (Transmit)
18	DPEN	Duplex Enable	44	REF_OUT	Frequency reference out
19	N/C	No Connect	45	REF_IN	Frequency reference in
20	N/C	No Connect	46	VDD	VDD (Transmit)
21	N/C	No Connect	47	VSS	VSS (LEDs)
22	VSS	VSS (Receive)	48	P0FD	Full duplex LED
23	MDIO	Management Data Input/Output	49	P1CL	Collision detect LED
24	MDC	Management Data Clock	50	P2LI	Link Integrity LED
25	RXD3	Receive Data 3	51	P3TD	Transmit data LED
26	RXD2	Receive Data 2	52	P4RD	Receive data LED

Pin Diagram

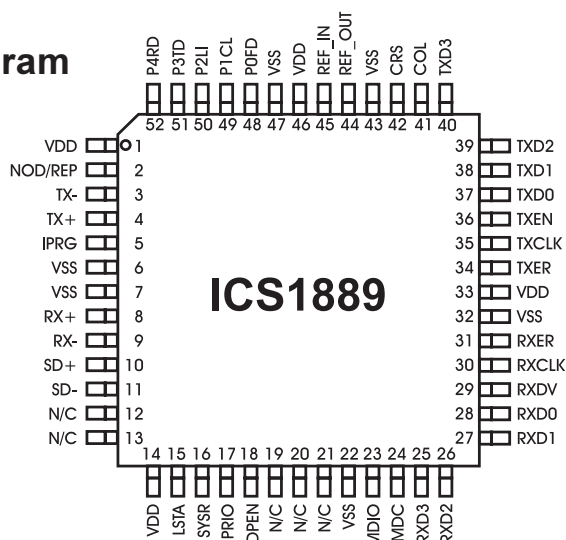



System Diagram

Adapter

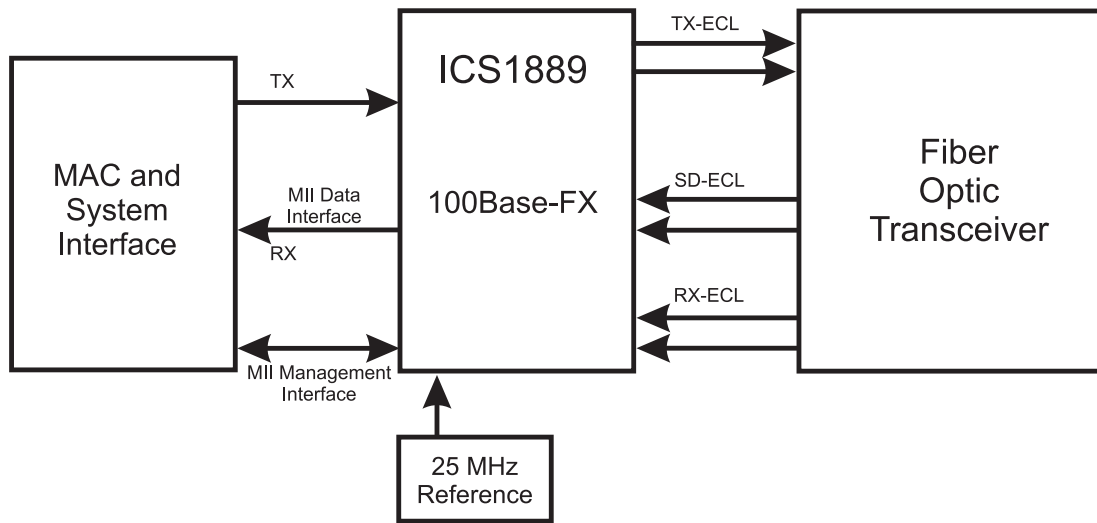



ICS1889

Absolute Maximum Ratings

V _{DD} (measured to V _{SS})	7.0 V
Digital Inputs/Outputs	V _{SS} - 0.5 V to V _{DD} + 0.5 V
Ambient Operating Temperature	-55°C to +125°C
Storage Temperature	-65°C to +150°C
Junction Temperature	175°C
Soldering Temperature	265°C

Stresses above those listed under *Absolute Maximum Ratings* above may cause permanent damage to the device. This is a stress rating only and functional operation of the device at these or any other conditions above those listed in the operational sections of the specifications is not implied. Exposure to absolute maximum rating conditions for extended periods may affect product reliability.

Recommended Operating Conditions

PARAMETER	SYMBOL	TEST CONDITIONS	MIN	MAX	UNITS
Ambient Operating Temp.	T _A		0	+70	°C
Using a Positive Supply	V _{SS} V _{DD}		0.0 +4.75	0.0 +5.25	V V

**DC Characteristics** $V_{DD} = V_{MIN}$ to V_{MAX} , $V_{SS} = 0V$, $T_A = T_{MIN}$ to T_{MAX}

PARAMETER	SYMBOL	CONDITIONS	MIN	MAX	UNITS
Supply Current	I_{DD}	$V_{DD} = +5.0V$, $V_{SS} = 0.0V$	—	80	mA
ECL Input / Output					
PARAMETER	SYMBOL	CONDITIONS	MIN	MAX	UNITS
ECL Input High Voltage	V_{IH}		$V_{DD} - 1.16$	$V_{DD} - 0.88$	V
ECL Input Low Voltage	V_{IL}		$V_{DD} - 1.81$	$V_{DD} - 1.47$	V
ECL Output High Voltage	V_{OH}		$V_{DD} - 1.02$	—	V
ECL Output Low Voltage	V_{OL}		—	$V_{DD} - 1.62$	V
TTL Input / Output					
PARAMETER	SYMBOL	CONDITIONS	MIN	MAX	UNITS
TTL Input High Voltage	V_{IH}	$V_{DD} = 5.0V$, $V_{SS} = 0.0V$	2.0	—	V
TTL Input Low Voltage	V_{IL}	$V_{DD} = 5.0V$, $V_{SS} = 0.0V$	—	0.8	V
TTL Output High Voltage	V_{OH}	$V_{DD} = 5.0V$, $V_{SS} = 0.0V$	2.4	—	V
TTL Output Low Voltage	V_{OL}	$V_{DD} = 5.0V$, $V_{SS} = 0.0V$	—	0.4	V
TTL Driving CMOS Output High Voltage	V_{OH}	$V_{DD} = 5.0V$, $V_{SS} = 0.0V$	3.68	—	V
TTL Driving CMOS Output Low Voltage	V_{OL}	$V_{DD} = 5.0V$, $V_{SS} = 0.0V$	—	0.4	V
TTL / CMOS Output Sink Current	I_{OL}	$V_{DD} = 5.0V$, $V_{SS} = 0.0V$	8	—	mA
TTL / CMOS Output Source Current	I_{OH}	$V_{DD} = 5.0V$, $V_{SS} = 0.0V$	—	-0.4	mA
REF_IN Input					
PARAMETER	SYMBOL	CONDITIONS	MIN	MAX	UNITS
Input High Voltage	V_{IH}	$V_{DD} = 5.0V$, $V_{SS} = 0.0V$	3.5	—	V
Input Low Voltage	V_{IL}	$V_{DD} = 5.0V$, $V_{SS} = 0.0V$	—	1.5	V

Note: REF_IN Input switch point is 50% of VDD.



ICS1889

Additional DC Electrical Specifications

THE TIMING VALUES ARE PRELIMINARY AND SUBJECT TO CHANGE.

T#	PARAMETER (conditions)	MIN	TYP	MAX	UNITS
t1	MII Input Pin Capacitance	—	8	—	pF
t2	MII Output Pin Capacitance	—	14	—	pF
t3	MII Input Pin Impedance	—	33	—	Ohms

Clocks — Reference In (REF-IN/REF+) To Transmit Clock TXCLK

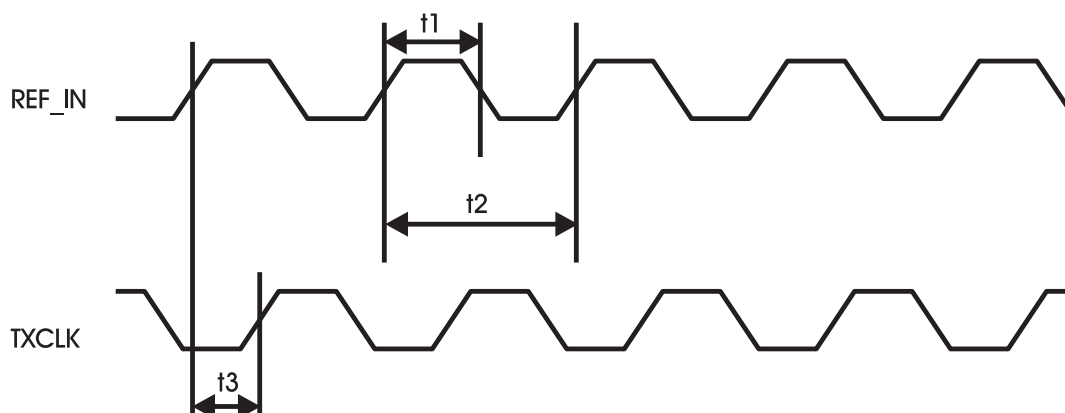

T#	PARAMETER (conditions)	MIN	TYP	MAX	UNITS
t1	REF_IN Duty Cycle	40	50	60	%
t2	REF_IN Period	—	40	—	ns
t3	REF_IN rise to TXCLK rise	0	1.5	3	ns

Note: REF-IN switching point is 50% of VDD.



Clocks — Transmit Clock Tolerance

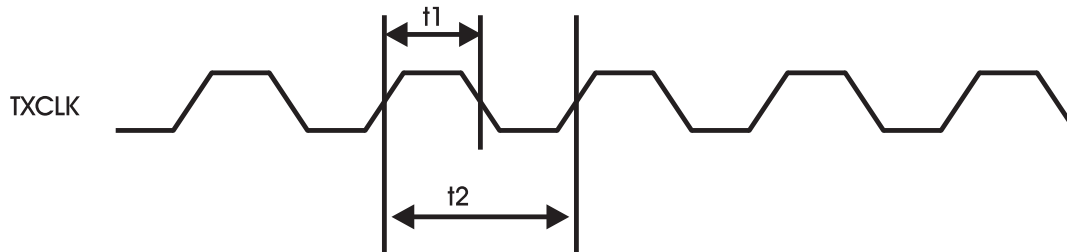

T#	PARAMETER (conditions)	MIN	TYP	MAX	UNITS
t1	TXCLK Duty Cycle	35	50	65	%
t2	TXCLK Period	—	40	—	ns

Note: TXCLK Duty Cycle = REF_IN Duty Cycle ± 5%.

Clocks — Receive Clock Behavior

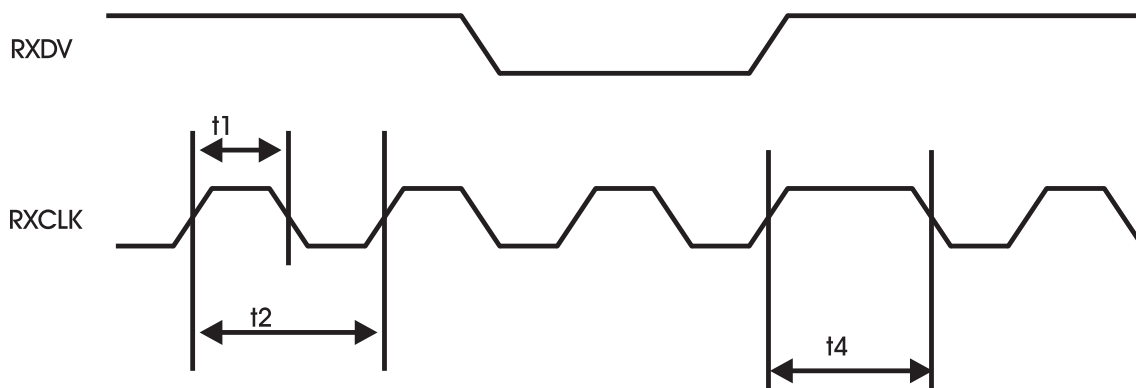

T#	PARAMETER (conditions)	MIN	TYP	MAX	UNITS
t1	RXCLK Duty Cycle	45	50	55	%
t2	RTXCLK Period	—	40	—	ns
t3	RXDV De-asserted Recovered Clock to Nominal Clock Cycle Extension (No Extension)	—	—	—	—
t4	RXDV De-asserted Nominal Clock to Recovered Clock Cycle Extension	—	—	60	ns



ICS1889

Clocks — Synchronous Transmit Timing

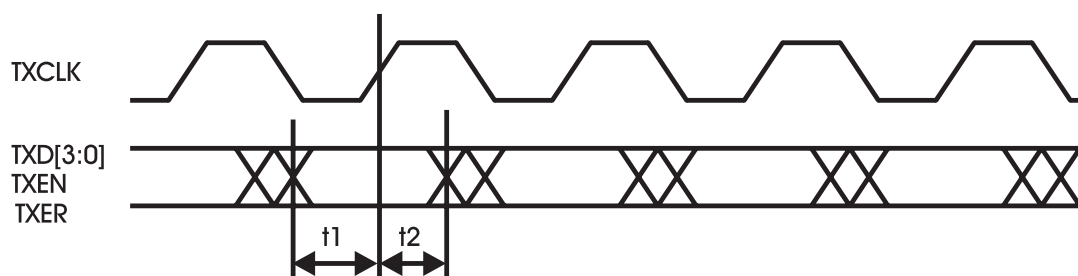

T#	PARAMETER (conditions)	MIN	TYP	MAX	UNITS
t1	TXD, TXEN, TXER Setup to TXCLK rise	10	—	—	ns
t2	TXD, TXEN, TXER hold after TXCLK rise	0	—	—	ns

Clocks — Synchronous Receive Timing

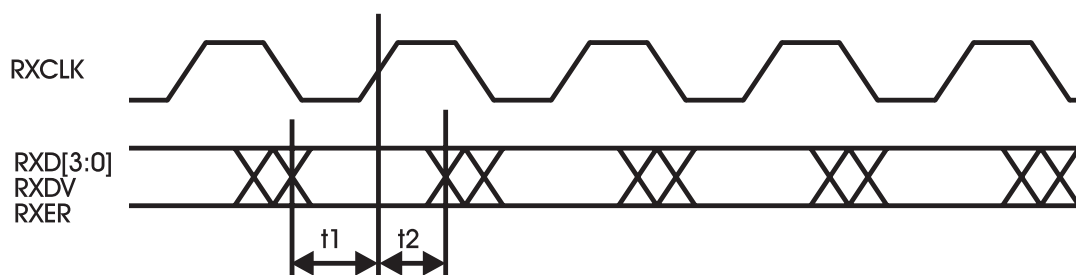

T#	PARAMETER (conditions)	MIN	TYP	MAX	UNITS
t1	RXD, RXDV, RXER Setup to RXCLK rise	13.0	—	—	ns
t2	RXD, RXDV, RXER Hold after RXCLK rise	12.5	—	—	ns

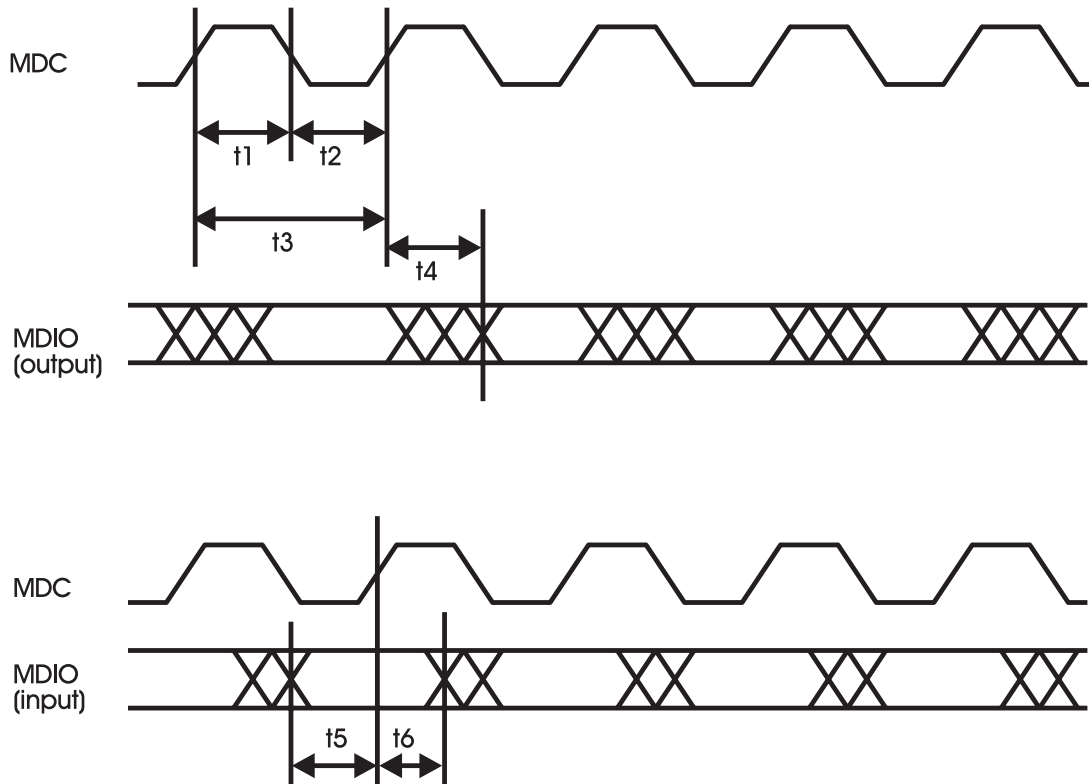
Clocks — Transmit Clock Tolerance

T#	PARAMETER (conditions)	MIN	TYP	MAX	UNITS
t1	MDC Minimum High Time	160	—	—	ns
t2	MDC Minimum Low Time	160	—	—	ns
t3	MDC Period	400	—	—	ns
t4	MDC rise to MDIO valid	0	—	300	ns
t5	MDIO Setup to MDC	15	—	—	ns
t6	MDIO Hold after MDC	0	—	—	ns
t7	Maximum allowable frequency (50pF Loading)	—	—	20	MHz



MII — Transmit Latency

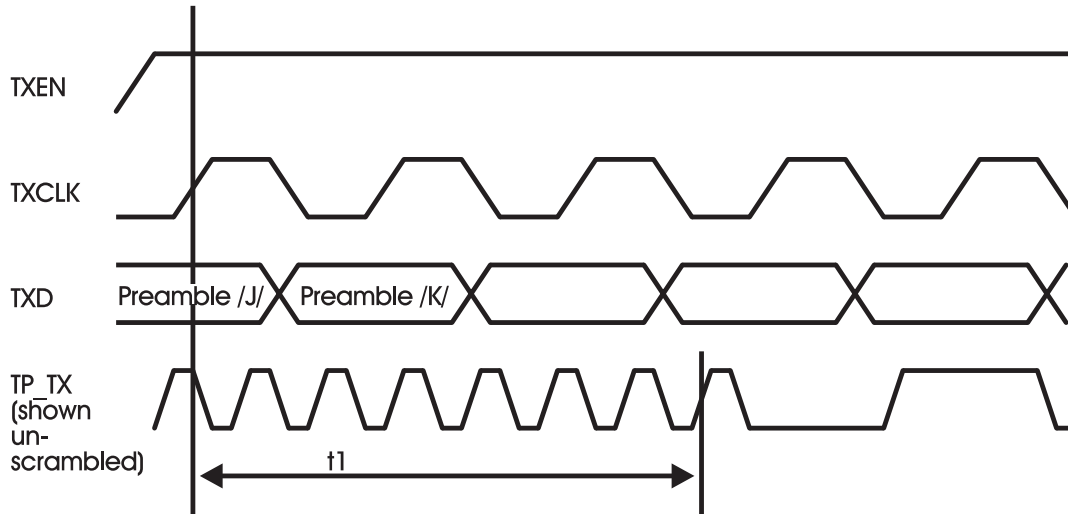

T#	PARAMETER (conditions)	MIN	TYP	MAX	UNITS
t1	TXEN sampled to MDI Output (1st bit of /J/ MII IF)*	—	8	9	bits

*Note: The IEEE maximum is 18 bits.

MII — Carrier Assertion/De-assertion on Transmission

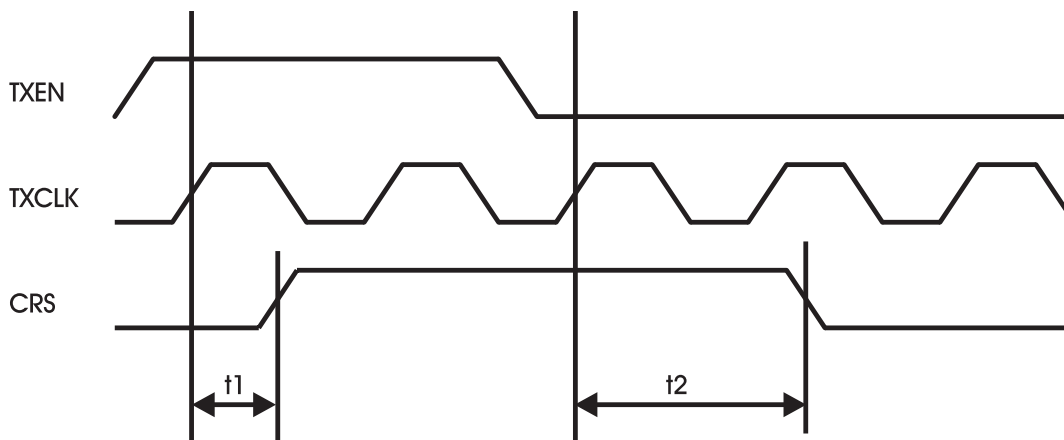

T#	PARAMETER (conditions)	MIN	TYP	MAX	UNITS
t1	TXEN sampled to CRS assert	0	4	5	bits
t2	TXEN sampled to CRS de-assert	0	4	5	bits



MII — Receive Latency

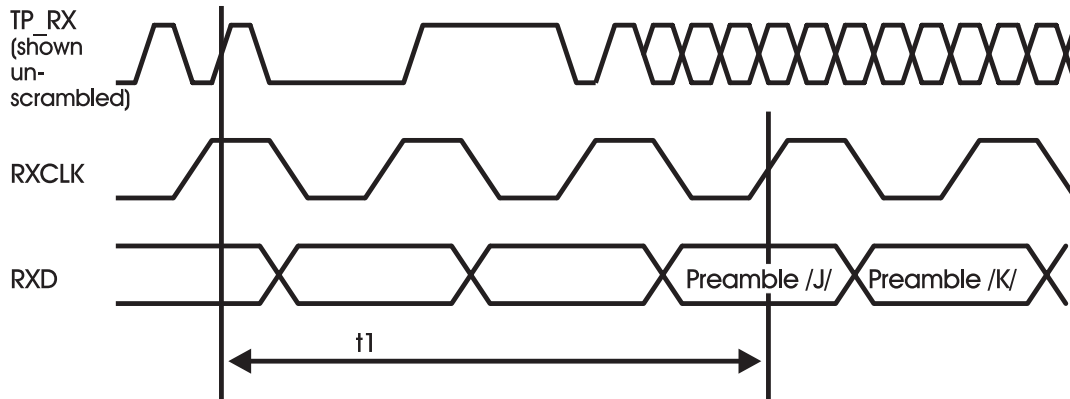

T#	PARAMETER (conditions)	MIN	TYP	MAX	UNITS
t1	1st bit of /J/ into TP_RX to /J/ on RXD (100M MII IF)	—	—	16	bits

*Note: The IEEE maximum is 23 bits.



MDI Input to Carrier Assertion / De-assertion

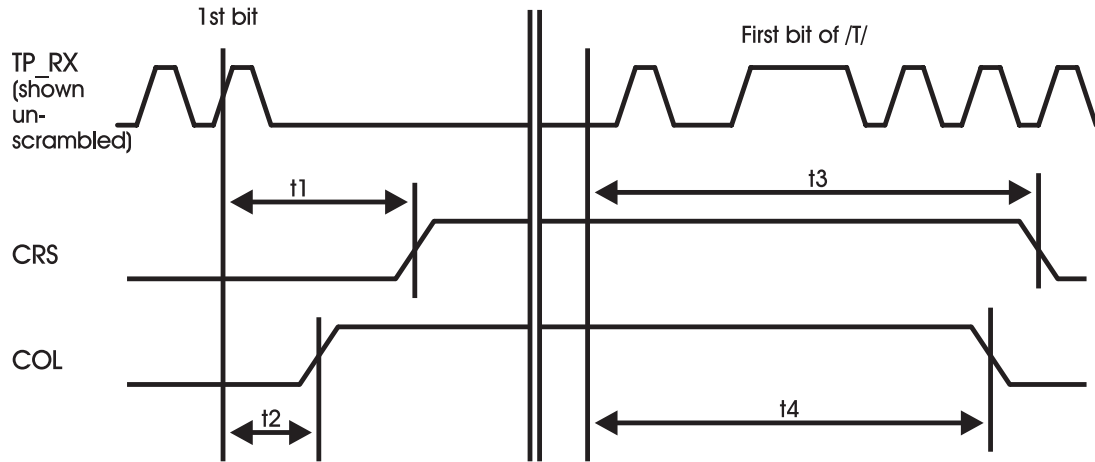

T#	PARAMETER (conditions)	MIN	TYP	MAX	UNITS
t1	1st bit of /J/ into TP_RX to CRS assert*	—	—	8	bits
t2	1st bit of /J/ into TP_RX while transmitting data to COL assert (Half Duplex Mode)*	—	—	8	bits
t3	1st bit of /T/ into TP_RX to CRS de-assert**	—	—	14	bits
t4	1st bit of /T/ into TP_RX to COL de-assert (Half Duplex Mode)**	—	—	14	bits

*Note: The IEEE maximum is 20 bit times.

**Note: The IEEE minimum is 13 bit times and the maximum is 24 bit times.



Reset — Power On Reset

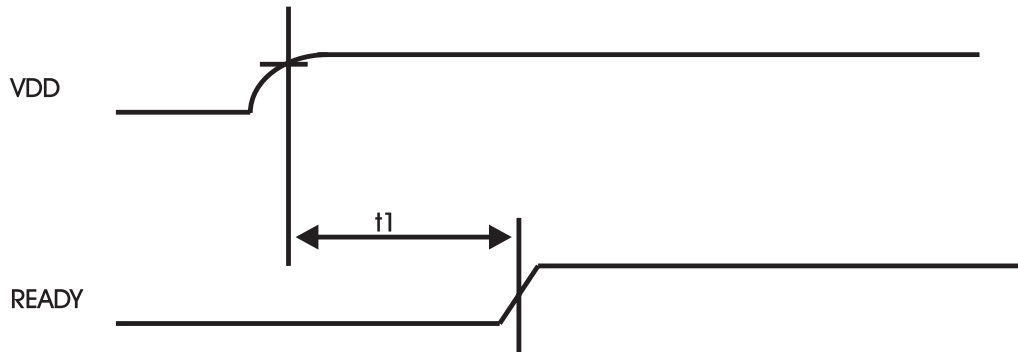

T#	PARAMETER (conditions)	MIN	TYP	MAX	UNITS
t1	VDD to 4V to Reset Complete	—	20	—	μs

Reset — Hardware Reset & Power-down

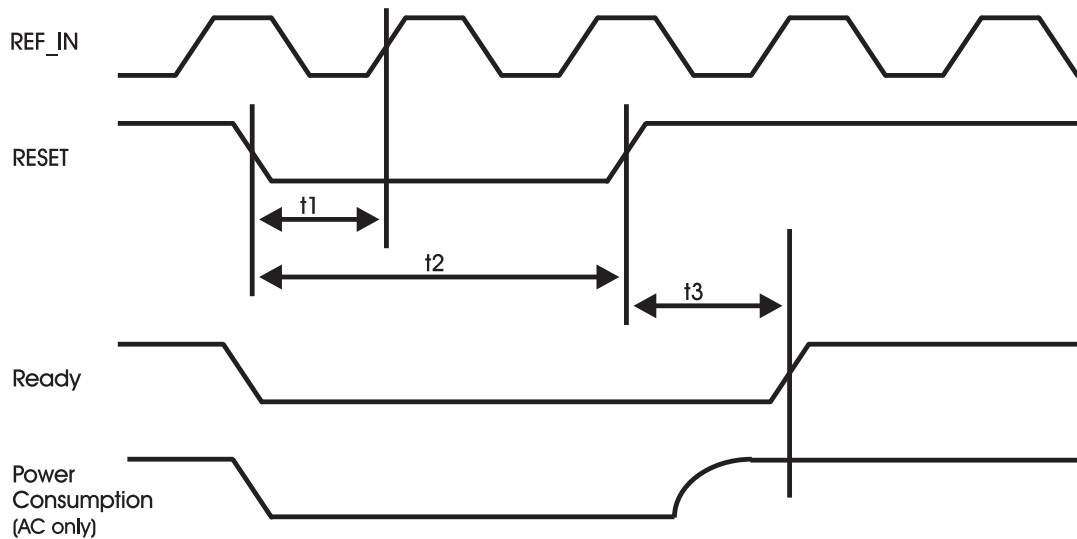

T#	PARAMETER (conditions)	MIN	TYP	MAX	UNITS
t1	Reset active to device isolation & initialization	—	—	200	ns
t2	Minimum RESET pulse width	80	—	—	ns
t3	RESET released to device ready	—	—	640	ns



Clock Recovery

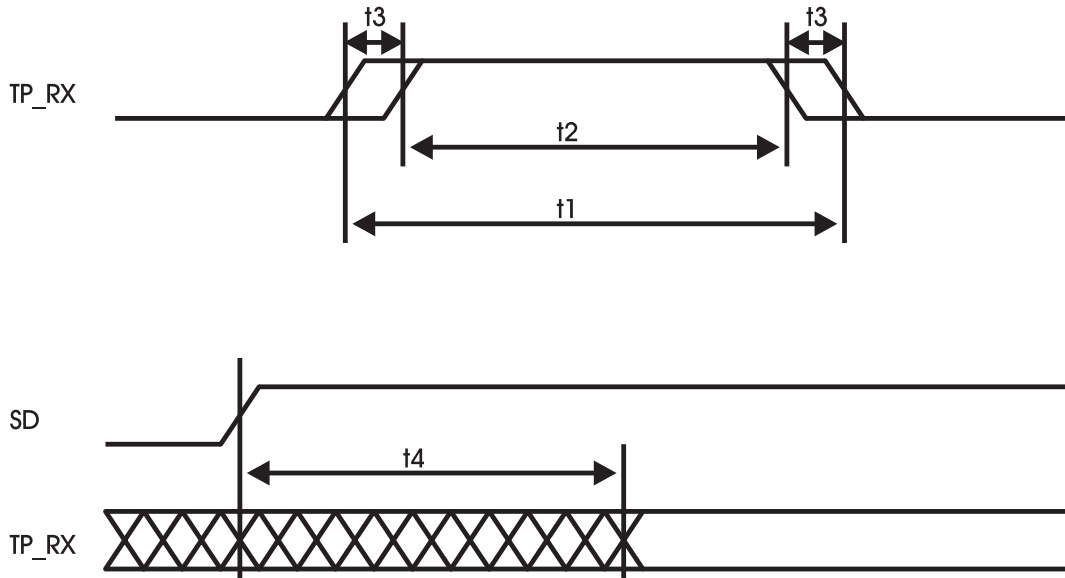

T#	PARAMETER (conditions)	MIN	TYP	MAX	UNITS
t1	Ideal data recovery window	—	—	8	ns
t2	Actual data recovery window	6	—	8	ns
t3	Data recovery window truncation	0	—	1	ns
t4	SD assert to data acquired	—	—	100	ns

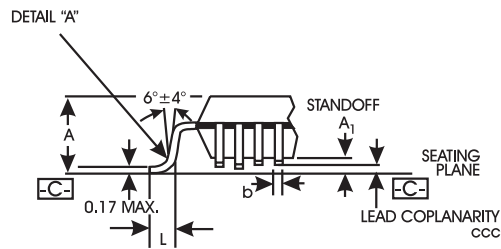
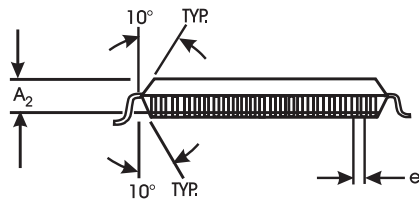
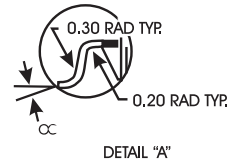
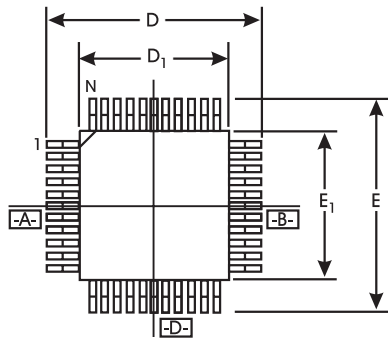

MQFP PACKAGE

LEAD COUNT (N)		52L
BODY THICKNESS		2.00
FOOTPRINT (BODY+)		3.20
DIMENSIONS	TOLERANCE	
A	MAX.	2.45
A1	MAX.	0.25
A2	+0.10 / -0.05	2.0
D	±0.25	17.20
D1	±0.10	14.00
E	±0.25	17.20
E1	±0.10	14.00
L	+0.15 / -0.10	0.88
e	BASIC	1.00
b	±0.05	0.35
ccc	MAX.	0.10
∞	—	0° - 7°C

Ordering Information ICS1889

Example:

ICS XXXX Y

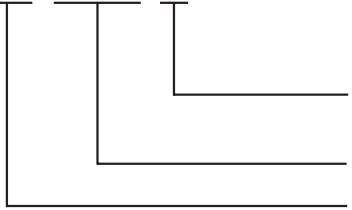

Package Type
Y = MQFP

Device Type (consists of 3 or 4 digit numbers)

Prefix
ICS, AV = Standard Device

ADVANCE INFORMATION documents contain information on new products in the sampling or preproduction phase of development. Characteristic data and other specifications are subject to change without notice.