

The **SM2527-50L** is a 2.5 to 2.7 GHz Solid State GaAs FET amplifier designed for various markets including Broadband Wireless Access. The unit provides a minimum of +50 dBm of Output Power at P1dB, an OIP3 of +68 dBm, and Linear Gain of 59 dB. Our proprietary pre-distortion technique improves the OIP3 by almost 8 dB. It is available in modular form (standard), or as a rack mountable amplifier.

Features

- Single Power Supply
- Over/Reverse Voltage Protection
- Thermal Protection with Auto Reset

Options

- Forward/Reverse Power Detection
- RF Sampling
- Integral Heatsink with two cooling fans
- Logic On/Off Control



Parameter	Specification
Frequency Range	2.5 - 2.7 GHz
Pout (P1dB) - 0° to 55°C	+50 dBm
Third Order Intercept Point	+68 dBm (typ.)
Linear Gain	59 dB ± 1 dB
Gain Flatness over Full Band	± 0.5 dB
Input/Output Return Loss	-14 dB / -14 dB
DC Input Voltage	+12 Volts
DC Input Current, typ.	31 Amps (Varies per application)
Mechanical Dimensions	w/cvr/htsk/fans: 10.75 x 7.5 x 4.7 inches without cvr/htsk/fans: 9.75 x 7.5 x .78 inches
RF Connectors	Input: SMA Female Output: N-Type Female
Operating Temperature	0°C to 55°C
Operating Humidity	95% Non-condensing
Operating Altitude	Up to 10,000 feet above Sea Level

DIMENSIONS IN INCHES

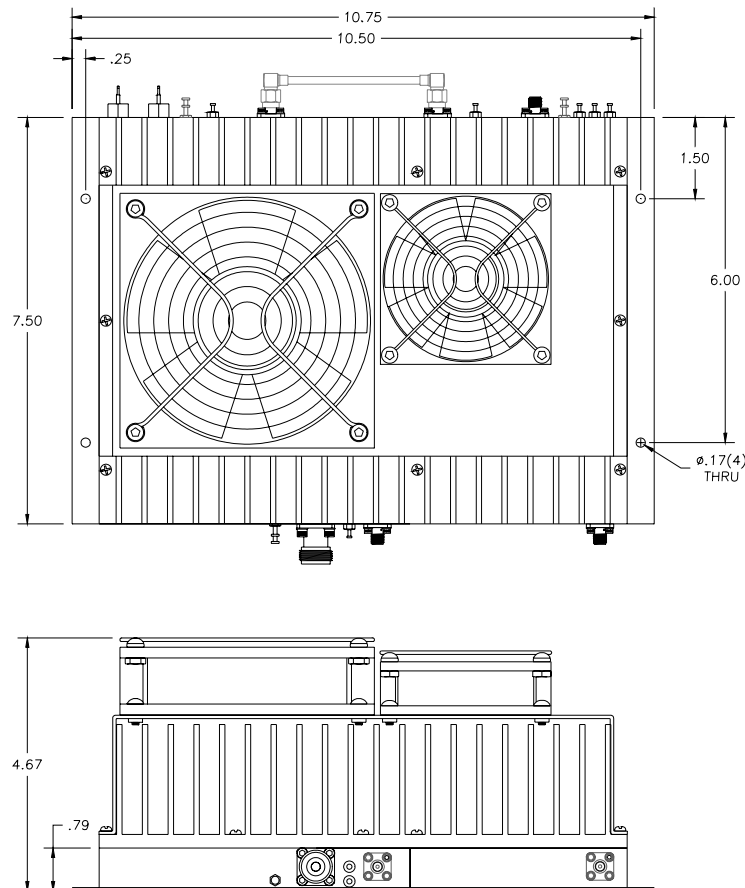

Pin	Description	Values
RF Input	Input Connector (SMA Female)	- 9 dBm, typical
RF OUT	Output Connector (N-Type Female)	+50 dBm @P1dB
RF SAMPLE	Sample RF Port (SMA Female)	30 dB
GND	Ground Turret	---
REV	Reverse Power Detector	∞ VSWR @ + 50 dBm \approx + 5.5 Volts
FWD	Forward Power Detector	+ 50 dBm Output Power \approx + 5.5 Volts
+12VDC	DC Input Voltage	+ 12 Volts @ 31 Amps (typ.)
On/Off	TTL Logic On/Off	0 Volts = Off, +5 Volts = On

Specifications subject to change without notice.