



Frequency Generator & Integrated Buffers for Celeron & PII/III™

Recommended Application:

440BX/VIA Apollo 133 style chipset.

Output Features:

- 2 - CPUs @ 2.5V or 3.3V up to 166MHz.
- 1 - IOAPIC @ 2.5V or 3.3V
- 13 - SDRAM @ 3.3V
- 6 - PCI @ 3.3V,
- 1 - 48MHz, @ 3.3V fixed.
- 1 - 24MHz @ 3.3V
- 2 - REF @ 3.3V, 14.318MHz.

Features:

- Up to 166MHz frequency support
- Supports power management: PCI, CPU stop and Mode
- Spread spectrum for EMI control (0 to -0.5%, ± 0.25%).
- Uses external 14.318MHz crystal

Skew Specifications:

- CPU – CPU: <175ps
- SDRAM - SDRAM: <500ps
- PCI – PCI: <500ps
- CPU-SDRAM: <500ps
- CPU(early)-PCI: Min=1.0ns, Typ=2.0ns, Max=4.0ns

Pin Configuration

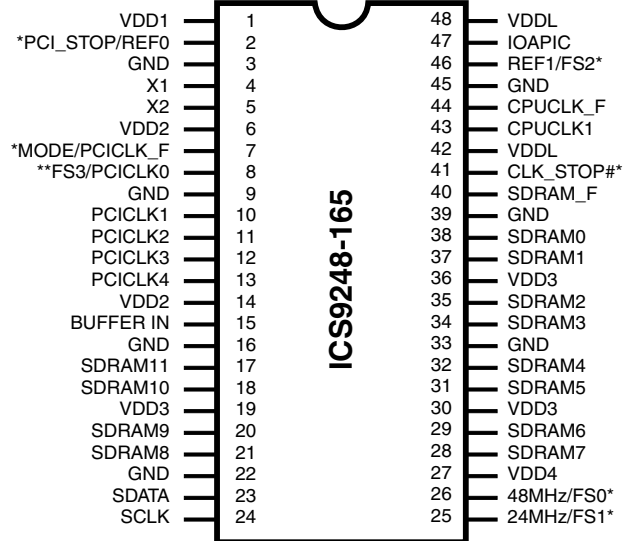

48-Pin 300mil SSOP

- * Internal Pull-up Resistor of 120K to VDD
- ** Internal Pull-down resistor of 120K to GND

Block Diagram

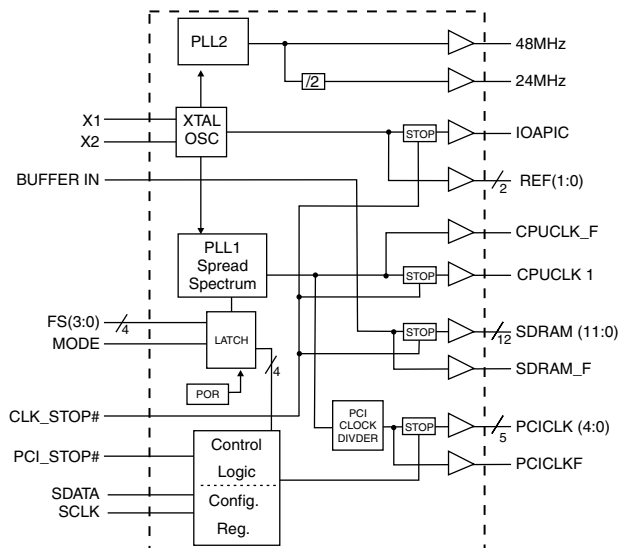

Functionality

FS3	FS2	FS1	FS0	CPU (MHz)	PCICLK (MHz)
0	0	0	0	80.00	40.00
0	0	0	1	75.00	37.50
0	0	1	0	83.31	41.65
0	0	1	1	66.82	33.41
0	1	0	0	103.00	34.33
0	1	0	1	112.01	37.34
0	1	1	0	68.01	34.01
0	1	1	1	100.23	33.41
1	0	0	0	120.00	40.00
1	0	0	1	114.99	38.33
1	0	1	0	109.99	36.66
1	0	1	1	105.00	35.00
1	1	0	0	140.00	35.00
1	1	0	1	150.00	37.50
1	1	1	0	124.00	31.00
1	1	1	1	133.90	33.47



Pin Descriptions

PIN NUMBER	PIN NAME	TYPE	DESCRIPTION
1	VDD1	PWR	REF, XTAL power supply, nominal 3.3V
2	REF0	OUT	14.318 Mhz reference clock.
	PCI_STOP# ¹	IN	Halts PCICLK clocks at logic 0 level, when input low (In mobile mode, MODE=0)
3,9,16,22,33,39,45	GND	PWR	Ground
4	X1	IN	Crystal input, has internal load cap (36pF) and feedback resistor from X2
5	X2	OUT	Crystal output, nominally 14.318MHz. Has internal load cap (36pF)
6,14	VDD2	PWR	Supply for PCICLK_F and PCICLK, nominal 3.3V
7	PCICLK_F	OUT	Free running PCI clock not affected by PCI_STOP# for power management.
	MODE ^{1, 2}	IN	Pin 7 function select pin, 1=Desktop Mode, 0=Mobile Mode. Latched Input.
8	FS3	IN	Frequency select pin. Latched Input. Internal Pull-down to GND
	PCICLK0	OUT	PCI clock outputs. Synchronous to CPU clocks with 1-48ns skew (CPU early)
13, 12, 11, 10	PCICLK (4:1)	OUT	PCI clock outputs. Synchronous to CPU clocks with 1-48ns skew (CPU early)
15	BUFFER IN	IN	Input to Fanout Buffers for SDRAM outputs.
17, 18, 20, 21, 28, 29, 31, 32, 34, 35,37,38	SDRAM (11:0)	OUT	SDRAM clock outputs, Fanout Buffer outputs from BUFFER IN pin (controlled by chipset).
19,30,36	VDD3	PWR	Supply for SDRAM and CPU PLL Core, nominal 3.3V.
23	SDATA	I/O	Data pin for I ² C circuitry, 5V tolerant input
24	SCLK	IN	Clock input of I ² C input, 5V tolerant input
25	24MHz	OUT	24MHz output clock
	FS1 ^{1, 2}	IN	Frequency select pin. Latched Input.
26	48MHz	OUT	48MHz output clock
	FS0 ^{1, 2}	IN	Frequency select pin. Latched Input
27	VDD4	PWR	Power for 24 & 48MHz output buffers and fixed PLL core.
40	SDRAM_F	OUT	Free running SDRAM clock output. Not affected by CLK_STOP#
41	CLK_STOP#	IN	This asynchronous input halts CPUCLK, IOAPIC & SDRAM clocks at logic "0" level when driven low.
42, 48	VDDL	PWR	Supply for CPU, IOAPIC clocks, either 2.5V or 3.3V nominal
43	CPUCLK1	OUT	CPU clock outputs, powered by VDDL2. Low if CLK_STOP#=Low
44	CPUCLK_F	OUT	Free running CPU clock. Not affected by the CLK_STOP#
46	REF1	OUT	14.318 MHz reference clock.
	FS2 ^{1, 2}	IN	Frequency select pin. Latched Input
47	IOAPIC	OUT	IOAPIC clock output. 14.318 MHz Powered by VDDL.

Notes:

- 1: Internal Pull-up Resistor of 120K to 3.3V on indicated inputs
- 2: Bidirectional input/output pins, input logic levels are latched at internal power-on-reset. Use 10Kohm resistor to program to VDD for logic high or GND for logic low.



General Description

The **ICS9248-165** is a single chip clock solution for Desktop designs. It provides all necessary clock signals for such a system.

Spread spectrum may be enabled through I²C programming. Spread spectrum typically reduces system EMI by 8dB to 10dB. This simplifies EMI qualification without resorting to board design iterations or costly shielding. The ICS9248-165 employs a proprietary closed loop design, which tightly controls the percentage of spreading over process and temperature variations.

Serial programming I²C interface allows changing functions, stop clock programming and frequency selection.

Power Groups

VDD1 = REF (1:0), X1, X2
VDD2 = PCICLK_F, PCICLK(4:0)
VDD3 = SDRAM (12:0), supply for PLL core
VDD4 = 24MHz, 48MHz
VDDL = IOAPIC, CPUCLK 1, CPUCLK_F

Mode Pin - Power Management Input Control

MODE, Pin 7 (Latched Input)	Pin 2
0	PCI_STOP# (Input)
1	REF0 (Output)



General I²C serial interface information

The information in this section assumes familiarity with I²C programming. For more information, contact ICS for an I²C programming application note.

How to Write:

- Controller (host) sends a start bit.
- Controller (host) sends the write address D2_(H)
- ICS clock will *acknowledge*
- Controller (host) sends a dummy command code
- ICS clock will *acknowledge*
- Controller (host) sends a dummy byte count
- ICS clock will *acknowledge*
- Controller (host) starts sending first byte (Byte 0) through byte 5
- ICS clock will *acknowledge* each byte *one at a time*.
- Controller (host) sends a Stop bit

How to Write:	
Controller (Host)	ICS (Slave/Receiver)
Start Bit	
Address D2 _(H)	
	ACK
Dummy Command Code	
	ACK
Dummy Byte Count	
	ACK
Byte 0	
	ACK
Byte 1	
	ACK
Byte 2	
	ACK
Byte 3	
	ACK
Byte 4	
	ACK
Byte 5	
	ACK
Stop Bit	

How to Read:

- Controller (host) will send start bit.
- Controller (host) sends the read address D3_(H)
- ICS clock will *acknowledge*
- ICS clock will send the *byte count*
- Controller (host) acknowledges
- ICS clock sends first byte (*Byte 0*) through *byte 5*
- Controller (host) will need to acknowledge each byte
- Controller (host) will send a stop bit

How to Read:	
Controller (Host)	ICS (Slave/Receiver)
Start Bit	
Address D3 _(H)	
	ACK
	Byte Count
ACK	
	Byte 0
ACK	
	Byte 1
ACK	
	Byte 2
ACK	
	Byte 3
ACK	
	Byte 4
ACK	
	Byte 5
ACK	
Stop Bit	

Notes:

1. The ICS clock generator is a slave/receiver, I²C component. It can read back the data stored in the latches for verification. **Read-Back will support Intel PIIX4 "Block-Read" protocol.**
2. The data transfer rate supported by this clock generator is 100K bits/sec or less (standard mode)
3. The input is operating at 3.3V logic levels.
4. The data byte format is 8 bit bytes.
5. To simplify the clock generator I²C interface, the protocol is set to use only "Block-Writes" from the controller. The bytes must be accessed in sequential order from lowest to highest byte with the ability to stop after any complete byte has been transferred. The Command code and Byte count shown above must be sent, but the data is ignored for those two bytes. The data is loaded until a Stop sequence is issued.
6. At power-on, all registers are set to a default condition, as shown.



Serial Configuration Command Bitmap

Byte0: Functionality and Frequency Select Register (default = 0)

Bit	Description					PWD	
Bit 2, Bit 7:4	Bit (2, 7, 6, 5, 4)					CPUCLK (MHz)	PCICLK (MHz)
	0	0	0	0	0	80.00	40.00
	0	0	0	0	1	75.00	37.50
	0	0	0	1	0	83.31	41.65
	0	0	0	1	1	66.82	33.41
	0	0	1	0	0	103.00	34.33
	0	0	1	0	1	112.01	37.34
	0	0	1	1	0	68.01	34.01
	0	0	1	1	1	100.23	33.41
	0	1	0	0	0	120.00	40.00
	0	1	0	0	1	114.99	38.33
	0	1	0	1	0	109.99	36.66
	0	1	0	1	1	105.00	35.00
	0	1	1	0	0	140.00	35.00
	0	1	1	0	1	150.00	37.50
	0	1	1	1	0	124.00	31.00
	0	1	1	1	1	133.90	33.47
	1	0	0	0	0	135.00	33.75
	1	0	0	0	1	129.99	32.50
	1	0	0	1	0	126.00	31.50
	1	0	0	1	1	118.00	39.33
	1	0	1	0	0	115.98	38.66
	1	0	1	0	1	95.00	31.67
	1	0	1	1	0	90.00	30.00
	1	0	1	1	1	85.01	28.34
	1	1	0	0	0	166.00	41.50
	1	1	0	0	1	160.01	40.00
	1	1	0	1	0	154.99	38.75
	1	1	0	1	1	147.95	36.99
	1	1	1	0	0	145.98	36.50
1	1	1	0	1	143.98	35.99	
1	1	1	1	0	141.99	35.50	
1	1	1	1	1	138.01	34.50	
Bit 3	0 - Frequency is selected by hardware select, Latched Inputs 1 - Frequency is selected by Bit 2, 7:4					0	
Bit 1	0 - Normal 1 - Spread Spectrum Enabled \pm 0.25% Center Spread					1	
Bit 0	0 - Running 1- Tristate all outputs					0	

XXXX
Note1

Note1: Default at power-up will be for latched logic inputs to define frequency, as displayed by Bit 3.

ICS9248-165



Byte 1: CPU, Active/Inactive Register (1= enable, 0 = disable)

BIT	PIN#	PWD	DESCRIPTION
Bit 7	-	X	Latched FS2#
Bit 6	-	1	(Reserved)
Bit 5	-	1	(Reserved)
Bit 4	-	1	(Reserved)
Bit 3	40	1	SDRAM_F
Bit 2	-	1	(Reserved)
Bit 1	43	1	CPUCLK1
Bit 0	44	1	CPUCLK_F

Byte 2: PCI, Active/Inactive Register (1= enable, 0 = disable)

BIT	PIN#	PWD	DESCRIPTION
Bit 7	-	1	(Reserved)
Bit 6	7	1	PCICLK_F
Bit 5	-	1	(Reserved)
Bit 4	13	1	PCICLK4
Bit 3	12	1	PCICLK3
Bit 2	11	1	PCICLK2
Bit 1	10	1	PCICLK1
Bit 0	8	1	PCICLK0

Byte 3: SDRAM, Active/Inactive Register (1= enable, 0 = disable)

BIT	PIN#	PWD	DESCRIPTION
Bit 7	-	1	(Reserved)
Bit 6	-	X	Latched FS0#
Bit 5	26	1	48MHz
Bit 4	25	1	24 MHz
Bit 3	-	1	(Reserved)
Bit 2	21,20, 18,17	1	SDRAM (8:11)
Bit 1	32,31, 29,28	1	SDRAM (4:7)
Bit 0	38,37, 35,34	1	SDRAM (0:3)

Byte 4: Reserved , Active/Inactive Register (1= enable, 0 = disable)

BIT	PIN#	PWD	DESCRIPTION
Bit 7	-	1	(Reserved)
Bit 6	-	1	(Reserved)
Bit 5	-	1	(Reserved)
Bit 4	-	1	(Reserved)
Bit 3	-	X	Latched FS1#
Bit 2	-	1	(Reserved)
Bit 1	-	X	Latched FS3#
Bit 0	-	1	(Reserved)

Byte 5: Peripheral , Active/Inactive Register (1= enable, 0 = disable)

BIT	PIN#	PWD	DESCRIPTION
Bit 7	-	1	(Reserved)
Bit 6	-	1	(Reserved)
Bit 5	-	1	(Reserved)
Bit 4	47	1	IOAPIC0
Bit 3	-	1	(Reserved)
Bit 2	-	1	(Reserved)
Bit 1	46	1	REF1
Bit 0	2	1	REF0

Byte 6: Peripheral , Active/Inactive Register (1= enable, 0 = disable)

BIT	PIN#	PWD	DESCRIPTION
Bit7	-	0	Reserved (Note)
Bit6	-	0	Reserved (Note)
Bit5	-	0	Reserved (Note)
Bit4	-	0	Reserved (Note)
Bit3	-	0	Reserved (Note)
Bit2	-	1	Reserved (Note)
Bit1	-	1	Reserved (Note)
Bit0	-	0	Reserved (Note)

Notes:

1. Inactive means outputs are held LOW and are disabled from switching.
2. Latched Frequency Selects (FS#) will be inverted logic load of the input frequency select pin conditions.

Note: Don't write into this register, writing into this register can cause malfunction



CLK_STOP# Timing Diagram

CLK_STOP# is an asynchronous input to the clock synthesizer. It is used to turn off the CPU, IOAPIC, SDRAM clocks for low power operation. CLK_STOP# is synchronized by the **ICS9248-165**. The minimum that the CPU clock is enabled (CLK_STOP# high pulse) is 100 CPU clocks. All other clocks will continue to run while the CPU, IOAPIC, SDRAM clocks are disabled. The CPU clocks will always be stopped in a low state and start in such a manner that guarantees the high pulse width is a full pulse. CPU clock on latency is less than 4 CPU clocks and CPU clock off latency is less than 4 CPU clocks.

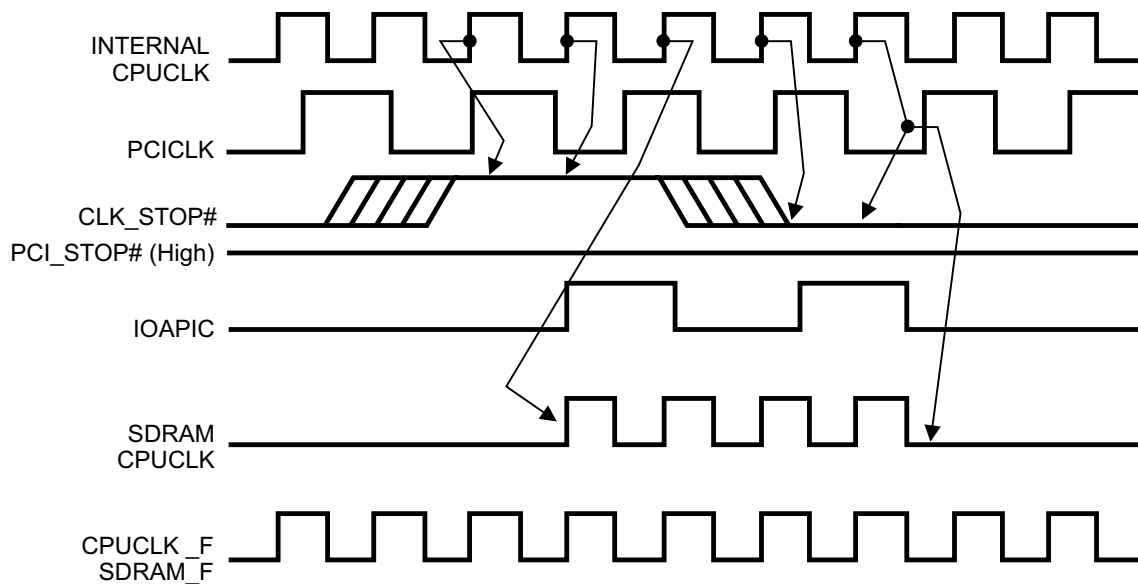

Notes:

1. All timing is referenced to the internal CPU clock.
2. CLK_STOP# is an asynchronous input and metastable conditions may exist. This signal is synchronized to the CPU clocks inside the ICS9248-165.
3. IOAPIC output is Stopped Glitch Free by CLK_STOP# going low.
4. SDRAM-F output is controlled by Buffer in signal, not affected by the **ICS9248-165** CLK_STOP# signal. SDRAM's are controlled as shown.
5. All other clocks continue to run undisturbed.



PCI_STOP# Timing Diagram

PCI_STOP# is an asynchronous input to the **ICS9248-165**. It is used to turn off the PCICLK clocks for low power operation. PCI_STOP# is synchronized by the **ICS9248-165** internally. The minimum that the PCICLK clocks are enabled (PCI_STOP# high pulse) is at least 10 PCICLK clocks. PCICLK clocks are stopped in a low state and started with a full high pulse width guaranteed. PCICLK clock on latency cycles are only one rising PCICLK clock off latency is one PCICLK clock.

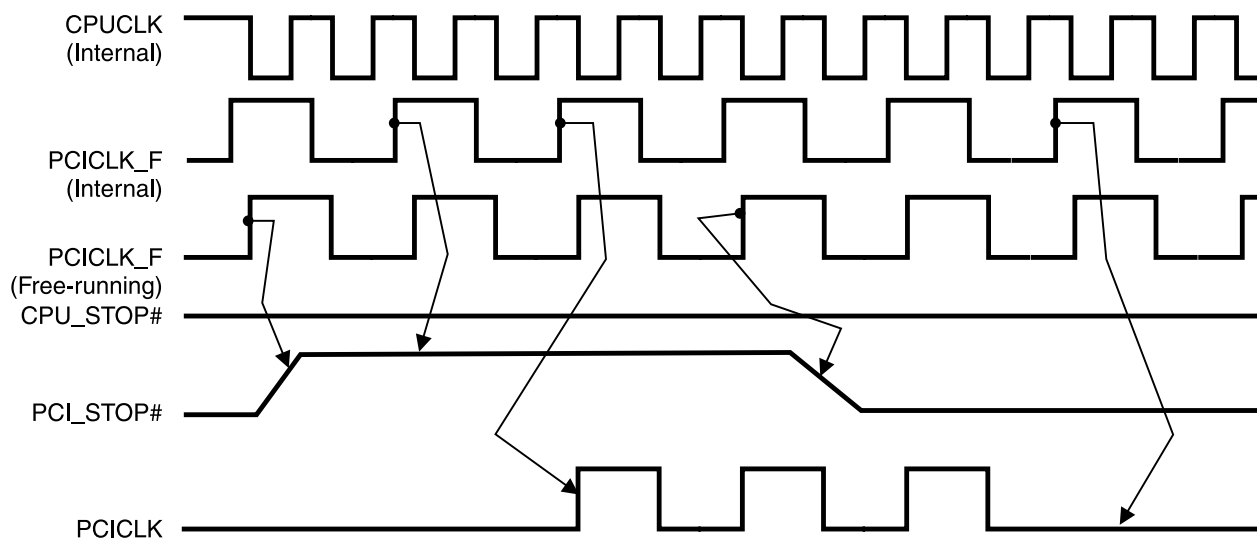

Notes:

1. All timing is referenced to the Internal CPUCLK (defined as inside the ICS9248-165 device.)
2. PCI_STOP# is an asynchronous input, and metastable conditions may exist. This signal is required to be synchronized inside the ICS9248-165.
3. All other clocks continue to run undisturbed.
4. CPU_STOP# is shown in a high (true) state.

Shared Pin Operation - Input/Output Pins

The I/O pins designated by (input/output) on the ICS9248-165 serve as dual signal functions to the device. During initial power-up, they act as input pins. The logic level (voltage) that is present on these pins at this time is read and stored into a 5-bit internal data latch. At the end of Power-On reset, (see AC characteristics for timing values), the device changes the mode of operations for these pins to an output function. In this mode the pins produce the specified buffered clocks to external loads.

To program (load) the internal configuration register for these pins, a resistor is connected to either the VDD (logic 1) power supply or the GND (logic 0) voltage potential. A 10 Kilohm (10K) resistor is used to provide both the solid CMOS programming voltage needed during the power-up programming period and to provide an insignificant load on the output clock during the subsequent operating period.

Figure 1 shows a means of implementing this function when a switch or 2 pin header is used. With no jumper is installed the pin will be pulled high. With the jumper in place the pin will be pulled low. If programmability is not necessary, than only a single resistor is necessary. The programming resistors should be located close to the series termination resistor to minimize the current loop area. It is more important to locate the series termination resistor close to the driver than the programming resistor.

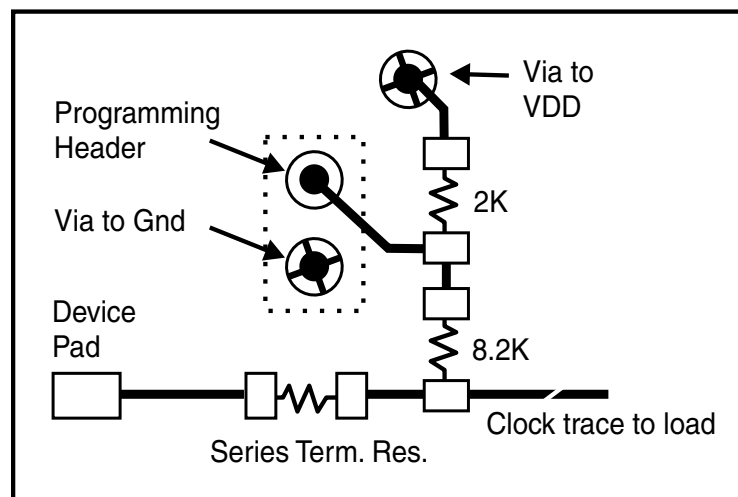

Fig. 1



Absolute Maximum Ratings

Supply Voltage	5.0 V
Logic Inputs	GND -0.5 V to $V_{DD} + 0.5$ V
Ambient Operating Temperature	0°C to +70°C
Case Temperature	115°C
Storage Temperature	-65°C to +150°C

Stresses above those listed under *Absolute Maximum Ratings* may cause permanent damage to the device. These ratings are stress specifications only and functional operation of the device at these or any other conditions above those listed in the operational sections of the specifications is not implied. Exposure to absolute maximum rating conditions for extended periods may affect product reliability.

Electrical Characteristics - Input/Supply/Common Output Parameters

$T_A = 0 - 70^\circ\text{C}$; Supply Voltage $V_{DD} = V_{DDL} = 3.3\text{ V} \pm 5\%$ (unless otherwise stated)

PARAMETER	SYMBOL	CONDITIONS	MIN	TYP	MAX	UNITS
Input High Voltage	V_{IH}		2		$V_{DD} + 0.3$	V
Input Low Voltage	V_{IL}		$V_{SS} - 0.3$		0.8	V
Input High Current	I_{IH}	$V_{IN} = V_{DD}$			5	uA
Input Low Current	I_{IL1}	$V_{IN} = 0$ V; Inputs with no pull-up resistors	-5			uA
Input Low Current	I_{IL2}	$V_{IN} = 0$ V; Inputs with pull-up resistors	-200			uA
Operating Supply Current	$I_{DD3.3OP66}$	$C_L = 0$ pF; Select @ 66.8 MHz		94	180	mA
	$I_{DD3.3OP100}$	$C_L = 0$ pF; Select @ 100 MHz		130		
Input frequency	F_i	$V_{DD} = 3.3$ V	12	14.318	16	MHz
Input Capacitance ¹	C_{IN}	Logic Inputs			5	pF
	C_{INX}	X1 & X2 pins	27		45	pF
Clk Stabilization ¹	T_{STAB}	From $V_{DD} = 3.3$ V to 1% target Freq.			3	ms

¹Guaranteed by design, not 100% tested in production.

Electrical Characteristics - Input/Supply/Common Output Parameters

$T_A = 0 - 70^\circ\text{C}$; Supply Voltage $V_{DD} = 3.3\text{ V} \pm 5\%$, $V_{DDL} = 2.5\text{ V} \pm 5\%$ (unless otherwise stated)

PARAMETER	SYMBOL	CONDITIONS	MIN	TYP	MAX	UNITS
Operating Supply Current	$I_{DD2.5OP66}$	$C_L = 0$ pF; Select @ 66.8 MHz		12	72	mA
	$I_{DD2.5OP100}$	$C_L = 0$ pF; Select @ 100 MHz		9	100	
Skew ¹	$T_{CPU-PCI}$	$V_T = 1.5$ V; $V_{TL} = 1.25$ V	1	2.46	4	ns

¹Guaranteed by design, not 100% tested in production.

**Electrical Characteristics - CPUCLK** $T_A = 0 - 70^\circ\text{C}$; $V_{DD} = 3.3\text{V} \pm 5\%$, $V_{DDL} = 2.5\text{V} \pm 5\%$; $C_L = 20\text{ pF}$ (unless otherwise stated)

PARAMETER	SYMBOL	CONDITIONS	MIN	TYP	MAX	UNITS
Output High Voltage	V_{OH2B}	$I_{OH} = -8\text{ mA}$	2	2.4		V
Output Low Voltage	V_{OL2B}	$I_{OL} = 12\text{ mA}$		0.17	0.4	V
Output High Current	I_{OH2B}	$V_{OH} = 1.7\text{ V}$		-58	-16	mA
Output Low Current	I_{OL2B}	$V_{OL} = 0.7\text{ V}$	19	46		mA
Rise Time ¹	t_{r2B}	$V_{OL} = 0.4\text{ V}$, $V_{OH} = 2.0\text{ V}$		1.08	1.6	ns
Fall Time ¹	t_{f2B}	$V_{OH} = 2.0\text{ V}$, $V_{OL} = 0.4\text{ V}$		0.96	1.6	ns
Duty Cycle ¹	d_{t2B}	$V_T = 1.25\text{ V}$	45	49.4	55	%
Skew window ¹	t_{sk2B}	$V_T = 1.25\text{ V}$		62	175	ps
Jitter, Cycle-to-cycle ¹	$t_{jyc-cyc2B}$	$V_T = 1.25\text{ V}$		216	250	ps

¹Guaranteed by design, not 100% tested in production.**Electrical Characteristics - PCICLK** $T_A = 0 - 70^\circ\text{C}$; $V_{DD} = 3.3\text{V} \pm 5\%$, $V_{DDL} = 2.5\text{V} \pm 5\%$; $C_L = 30\text{ pF}$ (unless otherwise stated)

PARAMETER	SYMBOL	CONDITIONS	MIN	TYP	MAX	UNITS
Output High Voltage	V_{OH1}	$I_{OH} = -11\text{ mA}$	2.4	3.15		V
Output Low Voltage	V_{OL1}	$I_{OL} = 9.4\text{ mA}$		0.13	0.4	V
Output High Current	I_{OH1}	$V_{OH} = 2.0\text{ V}$		-97	-40	mA
Output Low Current	I_{OL1}	$V_{OL} = 0.8\text{ V}$	41	69		mA
Rise Time ¹	t_{r1}	$V_{OL} = 0.4\text{ V}$, $V_{OH} = 2.4\text{ V}$		1.42	2.0	ns
Fall Time ¹	t_{f1}	$V_{OH} = 2.4\text{ V}$, $V_{OL} = 0.4\text{ V}$		1.35	2.0	ns
Duty Cycle ¹	d_{t1}	$V_T = 1.5\text{ V}$	45	51	55	%
Skew window ¹	t_{sk1}	$V_T = 1.5\text{ V}$		251	500	ps
Jitter, Absolute ¹	t_{jabs1}	$V_T = 1.5\text{ V}$	-500	180	500	ps

¹Guaranteed by design, not 100% tested in production.



Electrical Characteristics - SDRAM

$T_A = 0 - 70^\circ\text{C}$; $V_{DD} = 3.3\text{V} \pm 5\%$, $V_{DDL} = 2.5\text{V} \pm 5\%$; $C_L = 30\text{ pF}$ (unless otherwise stated)

PARAMETER	SYMBOL	CONDITIONS	MIN	TYP	MAX	UNITS
Output High Voltage	V_{OH3}	$I_{OH} = -28\text{ mA}$	2.4	3		V
Output Low Voltage	V_{OL3}	$I_{OL} = 20\text{ mA}$		0.18	0.4	V
Output High Current	I_{OH3}	$V_{OH} = 2.0\text{ V}$		-110	-40	mA
Output Low Current	I_{OL3}	$V_{OL} = 0.8\text{ V}$	41	86		mA
Rise Time ¹	t_{r3}	$V_{OL} = 0.4\text{ V}$, $V_{OH} = 2.4\text{ V}$		1.13	2	ns
Fall Time ¹	t_{f3}	$V_{OH} = 2.4\text{ V}$, $V_{OL} = 0.4\text{ V}$		1.11	2	ns
Duty Cycle ¹	d_{t3}	$V_T = 1.5\text{ V}$	45	53.1	55	%
Skew window ¹	t_{sk3}	$V_T = 1.5\text{ V}$		215	250	ps
Propagation Time ¹ (Buffer in to Output)	T_{prop}	$V_T = 1.5\text{ V}$		3.26	5	ns

¹Guaranteed by design, not 100% tested in production.

Electrical Characteristics - IOAPIC

$T_A = 0 - 70^\circ\text{C}$; $V_{DD} = 3.3\text{V} \pm 5\%$, $V_{DDL} = 2.5\text{V} \pm 5\%$; $C_L = 20\text{ pF}$ (unless otherwise stated)

PARAMETER	SYMBOL	CONDITIONS	MIN	TYP	MAX	UNITS
Output High Voltage	V_{OH4B}	$I_{OH} = -8\text{ mA}$	2	2.4		V
Output Low Voltage	V_{OL4B}	$I_{OL} = 12\text{ mA}$		0.17	0.4	V
Output High Current	I_{OH4B}	$V_{OH} = 1.7\text{ V}$		-58	-16	mA
Output Low Current	I_{OL4B}	$V_{OL} = 0.7\text{ V}$	19	46		mA
Rise Time ¹	t_{r4B}	$V_{OL} = 0.4\text{ V}$, $V_{OH} = 2.0\text{ V}$		1.14	2	ns
Fall Time ¹	t_{f4B}	$V_{OH} = 2.0\text{ V}$, $V_{OL} = 0.4\text{ V}$		1.07	2	ns
Duty Cycle ¹	d_{t4B}	$V_T = 1.25\text{ V}$	45	52.7	55	%
Jitter, Absolute ¹	t_{jabs4B}	$V_T = 1.25\text{ V}$	-1	0.27	1	ps

¹Guaranteed by design, not 100% tested in production.

**Electrical Characteristics - REF, 48MHz, 24MHz** $T_A = 0 - 70^\circ\text{C}$; $V_{DD} = 3.3\text{V} \pm 5\%$, $V_{DDL} = 2.5\text{V} \pm 5\%$; $C_L = 20\text{ pF}$ (unless otherwise stated)

PARAMETER	SYMBOL	CONDITIONS	MIN	TYP	MAX	UNITS
Output High Voltage	V_{OH5}	$I_{OH} = -12\text{ mA}$	2.4	3.03		V
Output Low Voltage	V_{OL5}	$I_{OL} = 10\text{ mA}$		0.23	0.4	V
Output High Current	I_{OH5}	$V_{OH} = 2.0\text{ V}$		-50	-22	mA
Output Low Current	I_{OL5}	$V_{OL} = 0.8\text{ V}$	16	40		mA
Rise Time ¹	t_{r5}	$V_{OL} = 0.4\text{ V}$, $V_{OH} = 2.4\text{ V}$		1.26	4.0	ns
Fall Time ¹	t_{f5}	$V_{OH} = 2.4\text{ V}$, $V_{OL} = 0.4\text{ V}$		1.57	4.0	ns
Duty Cycle ¹	d_{t5}	$V_T = 1.5\text{ V}$	45	53.3	55	%
Jitter, Absolute ¹	t_{jabs5}	$V_T = 1.5\text{ V}$	-1	0.25	1	ps

¹Guaranteed by design, not 100% tested in production.

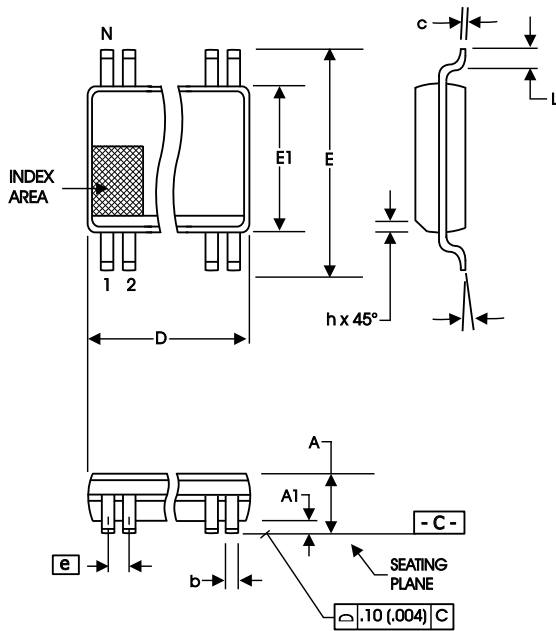

300 mil SSOP Package

SYMBOL	In Millimeters COMMON DIMENSIONS		In Inches COMMON DIMENSIONS	
	MIN	MAX	MIN	MAX
A	2.41	2.80	.095	.110
A1	0.20	0.40	.008	.016
b	0.20	0.34	.008	.0135
c	0.13	0.25	.005	.010
D	SEE VARIATIONS		SEE VARIATIONS	
E	10.03	10.68	.395	.420
E1	7.40	7.60	.291	.299
e	0.635 BASIC		0.025 BASIC	
h	0.38	0.64	.015	.025
L	0.50	1.02	.020	.040
N	SEE VARIATIONS		SEE VARIATIONS	
α	0°	8°	0°	8°

VARIATIONS

N	D mm.		D (inch)	
	MIN	MAX	MIN	MAX
48	15.75	16.00	.620	.630

Reference Doc.: JEDEC Publication 95, MO-118

10-0034

Ordering Information

ICS9248yF-165-T

Example:

ICS XXXX y F - PPP - T

- Designation for tape and reel packaging
- Pattern Number (2 or 3 digit number for parts with ROM code patterns)
- Package Type
F=SSOP
- Revision Designator (will not correlate with datasheet revision)
- Device Type (consists of 3 or 4 digit numbers)
- Prefix
ICS, AV = Standard Device