



Frequency Generator and Buffer for Pentium™ Systems

General Description

The ICS9159-06 is a low cost frequency generator designed specifically for Pentium systems. The integrated buffer minimizes skew and provides the early CPU clock required by some chipsets such as the OPTi VIPER. A 14.318 MHz XTAL oscillator provides the reference clock to generate standard Pentium frequencies. The CPU clock makes gradual frequency transitions without violating the PLL timing of internal microprocessor clock multipliers.

Asynchronous 33.3 MHz PCI bus operation is supported, in-dependent of the CPU operating frequency. Green PC systems are supported through power-down, doze, and glitch-free stop clock modes.

Features

- Four CPU clocks operate up to 66 MHz at 3.3V with glitch-free start and stop plus smooth transitions
- 3-6ns early CPU clock supports OPTi VIPER systems
- Selection of 8 frequencies, tristate, or power-down
- Six BUS clocks support asynchronous PCI bus operation
- ±250ps skew between synchronous outputs
- Integrated buffer outputs drive up to 30pF loads
- 3.1V -5.5V supply range
- 28-pin 300-mil SOIC package

Applications

- Ideal for green Pentium and 486 PCI systems

Block Diagram

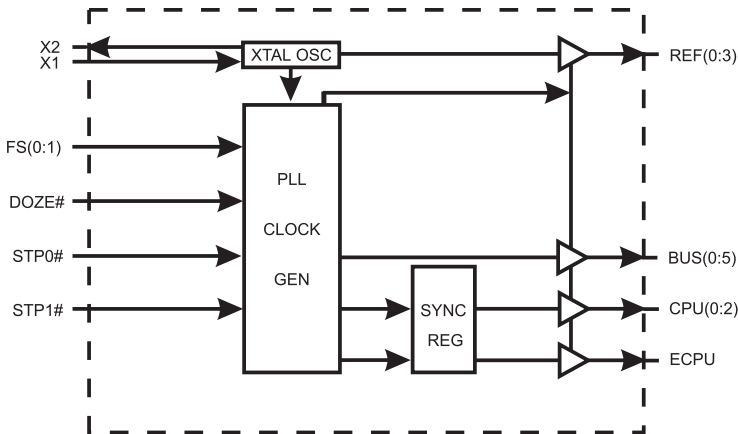

Functionality

3.1 to 5.5V, 0-70° Crystal=14.318 MHz input

STP0#	STP1#	DOZE#	FS(0:1)	CPU(0:1) (MHz)	CPU2, ECPU (MHz)	BUS(0:5) (MHz)	REF(0:3) (MHz)
1	X	1	00	66.6*	66.6*	33.3	14.318
1	X	1	01	60*	60*	33.3	14.318
1	X	1	10	50	50	33.3	14.318
1	X	1	11	40	40	33.3	14.318
1	X	0	00	33.3	33.3	16.7	14.318
1	X	0	01	30	30	16.7	14.318
1	X	0	10	25	25	16.7	14.318
1	X	0	11	22.5	22.5	16.7	14.318
0	1	1	- -	Stop	Run	Run	14.318
0	0	1	X X	Stop	Stop	Stop	14.318
0	0*	0*	X X	Low	Low	Low	14.318
0	1	0	X X	Tristate	Tristate	Tristate	14.318

* 3.3 volt operation only. ** 000 mode powers-down the PLL sections and forces the outputs low. To ensure glitch-free start and stop of the CPU and BUS clocks enter 000 from 001 and exit 000 through 001.

COMPAQ is a trademark of Compaq Computers.
Pentium is a trademark of Intel Corporation.



ICS9159-06

Preliminary Product Preview

Pin Configuration

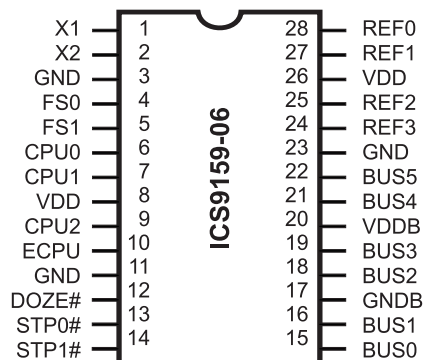

28-Pin 300-mil SOIC

Pin Descriptions

PIN NUMBER	PIN NAME	TYPE	DESCRIPTION
8, 26	VDD	PWR	Power for logic, CPU and fixed frequency output buffers.
1	X1	IN	XTAL or external reference frequency input. This input includes XTAL load capacitance and feedback bias for a 0.5 - 20 MHz XTAL.**
2	X2	OUT	XTAL output which includes XTAL load capacitance.**
3, 11, 23	GND	PWR	Ground for logic, CPU and fixed frequency output buffers.
6, 7, 9	CPU(0:2)	OUT	Processor clock outputs which are a multiple of the input reference frequency as shown in the table.
4, 5	FS(0:1)	IN	Frequency multiplier select pins. See table. These inputs have internal pull-up devices.
20	VDDDB	PWR	Power for BUS output buffers.
15, 16, 18 19, 21, 22	BUS(0:5)	OUT	Bus clock outputs are fixed at 33.3 or 16.7 MHz.*
24, 25, 27, 28	REF(0:3)	OUT	REF is a buffered copy of the crystal oscillator or reference input clock, nominally 14.31818 MHz.*
10	ECPU	OUT	Early processor clock output which is the same frequency as CPU(0:2). This clock leads CPU(0:2) by 3-6nS.
12	DOZE#	IN	Reduces CPU, ECPU and BUS clock outputs as shown in the functionality table when at a logic low level.
13, 14	STP0#, STP1#	IN	Synchronously stops the CPU, ECPU and BUS clocks per the description in the functionality table. Can also be used to tristate all outputs when the DOZE pin is low.
17	GNCB	PWR	This ground return path is brought on separately to permit separating the noise impulses from high output buffers from affecting sensitive internal circuitry.***

* Assuming 14.31818 MHz input clock or crystal.

** Device provides 18pF load for crystal load capacitance at each pin.

*** Ground for bus clock buffers.



Absolute Maximum Ratings

Supply Voltage	7.0 V
Logic Inputs	GND -0.5 V to $V_{DD} + 0.5$ V
Ambient Operating Temperature	0°C to +70°C
Storage Temperature	-65°C to +150°C

Stresses above those listed under Absolute Maximum Ratings may cause permanent damage to the device. These ratings are stress specifications only and functional operation of the device at these or any other conditions above those listed in the operational sections of the specifications is not implied. Exposure to absolute maximum rating conditions for extended periods may affect product reliability.

Electrical Characteristics at 3.3V

$V_{DD} = 3.0 - 3.7$ V, $T_A = 0 - 70^\circ$ C unless otherwise stated

DC Characteristics						
PARAMETER	SYMBOL	TEST CONDITIONS	MIN	TYP	MAX	UNITS
Input Low Voltage	V_{IL}		-	-	$0.2V_{DD}$	V
Input High Voltage	V_{IH}		$0.7V_{DD}$	-	-	V
Input Low Current	I_{IL}	$V_{IN}=0V$	-28.0	-10.5	-	μA
Input High Current	I_{IH}	$V_{IN}=V_{DD}$	-5.0	-	5.0	μA
Output Low Current ¹	I_{OL}	$V_{OL}=0.8V$; for CPU & BUS	30.0	47.0	-	mA
Output High Current ¹	I_{OH}	$V_{OL}=2.0V$; for CPU & BUS	-	-66.0	-42.0	mA
Output Low Current ¹	I_{OL}	$V_{OL}=0.8V$; for REF	25.0	38.0	-	mA
Output High Current ¹	I_{OH}	$V_{OL}=2.0V$; for REF	-	-47.0	-30.0	mA
Output Low Voltage	V_{OL}	$I_{OL}=15mA$; for CPU & BUS	-	0.30	.4	V
Output High Voltage ¹	V_{OH}	$I_{OH}=-30mA$; for CPU & BUS	2.4	2.8	-	V
Output Low Voltage	V_{OL}	$I_{OL}=12.5mA$; for REF	-	0.30	.4	V
Output High Voltage ¹	V_{OH}	$I_{OH}=-20mA$; for REF	2.4	2.8	-	V
Supply Current	I_{DD}	@66.66 MHz; all outputs unloaded	-	55	110	mA
Supply Current, Power-down	$I_{DD} (PD)$	@000 Mode (Power-down)	-	8	20	mA
Supply Current, Stop Mode	$I_{DD} (STOP)$	@001 Mode (Stop Mode)	-	35	70	mA

Note 1: Parameter is guaranteed by design and characterization. Not 100% tested in production.



ICS9159-06

Preliminary Product Preview

Electrical Characteristics at 3.3V

$V_{DD} = 3.1 - 3.7 V$, $T_A = 0 - 70^\circ C$

AC Characteristics						
PARAMETER	SYMBOL	TEST CONDITIONS	MIN	TYP	MAX	UNITS
Rise Time ¹	T_{r1}	20pF load, 0.8 to 2.0V, CPU & BUS	-	0.9	1.5	ns
Fall Time ¹	T_{f1}	20pF load, 2.0 to 0.8V, CPU & BUS	-	0.8	1.4	ns
Rise Time ¹	T_{r2}	20pF load, 20% to 80%, CPU & BUS	-	1.5	2.5	ns
Fall Time ¹	T_{f2}	20pF load, 80% to 20%, CPU & BUS	-	1.4	2.4	ns
Duty Cycle ¹	D_t	20pF load; @VOUT=1.4V	40	50	60	%
Jitter, One Sigma ¹	T_{j1s}	CPU; ECPU Load=20pF; FOUT >25 MHz	-	60	150	ps
Jitter, Absolute ¹	T_{jab}	CPU; ECPU Load=20pF, FOUT >25 MHz	-350	-	350	ps
Jitter, One Sigma ¹	T_{j1s}	BUS(0:2); REF(0:3); CPU ≥ 25 MHz; Load=20pF; Comp. to the period	-	0.7	2.0	%
Jitter, Absolute ¹	T_{jab}	BUS(0:2); REF(0:3); CPU ≥ 25 MHz; Load=20pF; Comp. to the period	-3.0	-	3.0	%
Input Frequency ¹	F_i	0.5 14.318 20 MHz Logic Input Capacitance 1 CIN Logic input pins	-	5	-	pF
Crystal Oscillator Capacitance ¹	CINX	X1, X2 pins	-	18	-	pF
Power-on Time ¹	t_{on}	From $V_{DD}=1.6V$ to 1 st crossing of 66.6 MHz V_{DD} supply ramp < 40ms	-	2.5	4.5	ms
Frequency Settling Time ¹	t_s	From 1 st crossing of acquisition to <1% settling	-	2.0	4.0	ms
Clock Skew Window ¹	T_{sk1}	CPU to CPU; Load=20pF; @1.4V	-	150	250	ps
Clock Skew Window ¹	T_{sk2}	BUS to BUS and REF to REF; Load=20pF; @1.4V	-	300	500	ps
Clock Skew Window ¹	T_{sk3}	ECPU to CPU(0:2); Load=20pF; @1.4V	3.0	5.0	6.0	ns

Note 1: Parameter is guaranteed by design and characterization. Not 100% tested in production.

**Electrical Characteristics at 5.5V** $V_{DD} = 4.5 - 5.5 \text{ V}$, $T_A = 0 - 70^\circ \text{ C}$

DC Characteristics						
PARAMETER	SYMBOL	TEST CONDITIONS	MIN	TYP	MAX	UNITS
Input Low Voltage	V_{IL}		-	-	$0.2V_{DD}$	V
Input High Voltage	V_{IH}		$0.7V_{DD}$	-	-	V
Input Low Current	I_{IL}	$V_{IN} = 0\text{V}$	-40.0	16.0	-	μA
Input High Current	I_{IH}	$V_{IN} = V_{DD}$	-5.0	-	5.0	μA
Output Low Current ¹	I_{OL}	$V_{OL} = 0.8\text{V}$; for CPU & BUS	40.0	62.0	-	mA
Output High Current ¹	I_{OH}	$V_{OL} = 2.0\text{V}$; for CPU & BUS	-	-140.0	-90.0	mA
Output Low Current ¹	I_{OL}	$V_{OL} = 0.8\text{V}$; for REF	30.0	50.0	-	mA
Output High Current ¹	I_{OH}	$V_{OL} = 2.0\text{V}$; for REF	-	-100.0	-60.0	mA
Output Low Voltage	V_{OL}	$I_{OL} = 20\text{mA}$; for CPU & BUS	-	0.3	0.4	V
Output High Voltage ¹	V_{OH}	$I_{OH} = -70\text{mA}$; for CPU & BUS	2.4	2.8	-	V
Output Low Voltage	V_{OL}	$I_{OL} = 15\text{mA}$; for REF	-	0.30	.4	V
Output High Voltage ¹	V_{OH}	$I_{OH} = -50\text{mA}$; for REF	2.4	2.8	-	V
Supply Current	I_{DD}	@50.0 MHz; all outputs unloaded	-	95.0	200.0	mA
Supply Current, Power-down	$I_{DD(PD)}$	@000 Mode (Power-down)	-	16.0	40.0	mA
Supply Current, Stop Mode	$I_{DD(STOP)}$	@001 Mode (Stop Mode)	-	70.0	140.0	mA

Note 1: Parameter is guaranteed by design and characterization. Not 100% tested in production.



ICS9159-06

Preliminary Product Preview

Electrical Characteristics at 5.5V

$V_{DD} = 4.5 - 5.5 \text{ V}$, $T_A = 0 - 70^\circ \text{ C}$

AC Characteristics						
PARAMETER	SYMBOL	TEST CONDITIONS	MIN	TYP	MAX	UNITS
Rise Time ¹	T_{r1}	20pF load, 0.8 to 2.0V, CPU & BUS	-	0.55	0.95	ns
Fall Time ¹	T_{f1}	20pF load, 2.0 to 0.8V, CPU & BUS	-	0.52	0.90	ns
Rise Time ¹	T_{r2}	20pF load, 20% to 80%, CPU & BUS	-	1.2	2.1	ns
Fall Time ¹	T_{f2}	20pF load, 80% to 20%, CPU & BUS	-	1.1	2.0	ns
Duty Cycle ¹	D_{t1}	20pF load; @VOUT=1.4V	50	56	70	%
Duty Cycle ¹	D_{t2}	20pF load; @VOUT=50%	40	50	60	%
Jitter, One Sigma ¹	T_{j1s}	CPU; ECPU Load=20pF; FOUT > 25 MHz	-	60	150	ps
Jitter, Absolute ¹	T_{jab}	CPU; ECPU Load=20pF, FOUT > 25 MHz	-350	-	350	ps
Jitter, One Sigma ¹	T_{j1s}	BUS(0:2); REF(0:3); CPU≥25 MHz; Load=20pF; Comp. to the period	-	0.7	2.0	%
Jitter, Absolute ¹	T_{jab}	BUS(0:2); REF(0:3); CPU≥25 MHz; Load=20pF; Comp. to the period	-3.0	-	3.0	%
Input Frequency ¹	F_i		0.5	14.318	20	MHz
Logic Input Capacitance ¹	C_{IN}	Logic input pins	-	5	-	pF
Crystal Oscillator Capacitance ¹	C_{INX}	X1, X2 pins	-	8	-	pF
Power-on Time ¹	t_{on}	From VDD=1.6V to 1st crossing of 50.0 MHz V_{DD} supply ramp < 40ms	-	2.5	4.5	ms
Frequency Settling Time ¹	t_s	From 1 st crossing of acquisition to < 1% settling	-	2.0	4.0	ms
Clock Skew Window ¹	T_{sk1}	CPU to CPU; Load=20pF; @1.4V	-	150	250	ps
Clock Skew Window ¹	T_{sk2}	BUS to BUS and REF to REF; Load=20pF; @1.4V	-	300	500	ps
Clock Skew Window ¹	T_{sk3}	ECPU to CPU(0:2); Load=20pF; @1.4V	3.0	5.0	6.0	ns

Note 1: Parameter is guaranteed by design and characterization. Not 100% tested in production.



ICS9159-06

Preliminary Product Preview

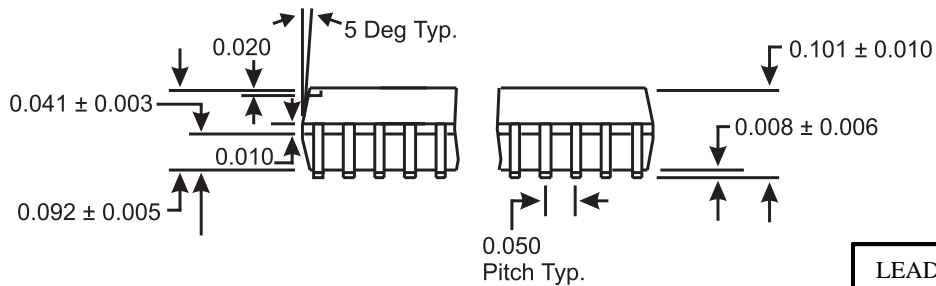
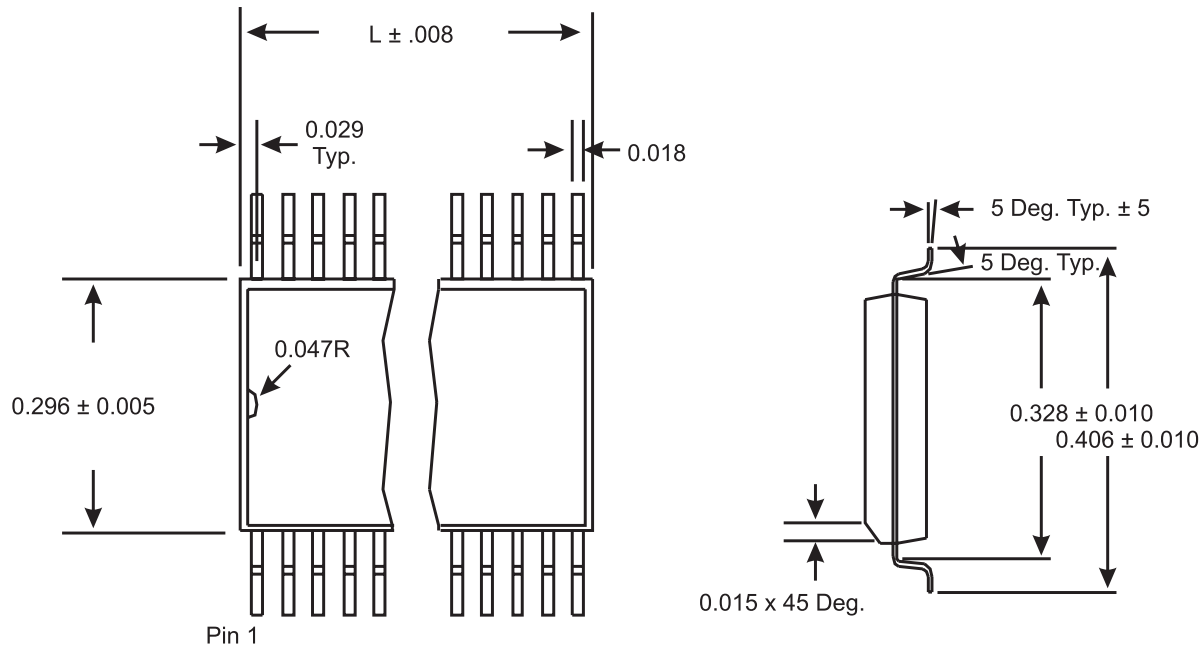

LEAD COUNT	28L
DIMENSIONL	0.704

SOIC Package

Ordering Information

ICS9159M-06

Example:

ICS XXXX M-PPP

