

Preliminary Data Sheet



Bipolar Analog Integrated Circuit μ PC3230GR

AGC AMPLIFIER + PRE AMPLIFIER IC

DESCRIPTION

The μ PC3230GR is silicon bipolar monolithic IC designed for use as Dual path AGC amplifier for digital TV, Digital CATV.

This IC consists of Dual path AGC amplifier for QAM path and analog one to B/B block of STB.

The package is 16-pin SSOP Package suitable for surface mount.

This IC is manufactured using our 30 GHz fmax UHS0 (Ultra High Speed Process) silicon bipolar process.

This process uses silicon nitride passivation film. This material can protect chip surface from external pollution and prevent corrosion /migration. Thus, this IC has excellent performance, uniformly and reliability.

FEATURES

- f(in):30~100MHz

AGC AMPLIFIERBLOCK

- ICC :37mA @5.0V
- Gmax:30dB
- GCR:40dB
- IM3:45dBc(min)/53dB(typ)@Output=0.5Vp-p/tone

PRE AMPLIFIER BLOCK

- ICC :61mA @5.0V
- Gain :28dB(typ)
- NF :6.6dB(typ)
- IM3:58dB(typ)@Output=2.5Vp-p/tone

Package

High-density surface mounting : 16-pin SSOP package (5.2×4.4×1.5mm)

APPLICATIONS

- Digital CATV
- Cable modem receivers

ORDERING INFORMATION (PLAN)

Part Number	Package	Supplying Form
μ PC3230GR-E1-A	16-pin plastic SSOP (5.72mm(225)) (Pb-Free) <small>Note</small>	Embossed tape 12mm wide. Pin 1 indicates pull-out direction of tape. Qty 2.5kpcs/reel.

Note With regards to terminal solder (the solder contains lead) plated products (conventionally plated), contact your nearby sales office.

Remark To order evaluation samples, please contact your local NEC sales office.

Part number for sample order: μ PC3230GR

INTERNAL BLOCK DIAGRAM AND PIN CONFIGURATION

(Top View)

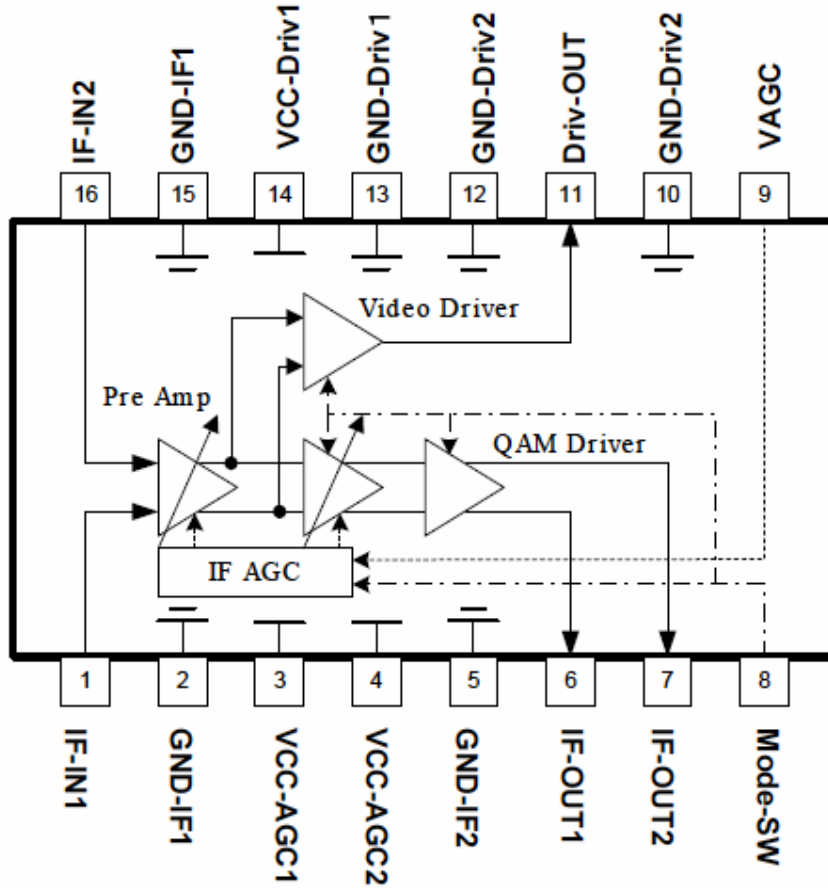

Preliminary Data Sheet

ABSOLUTE MAXIMUM RATINGS

Parameter	Symbol	Test Condition	Rating	Unit
Supply Voltage	V _{CC}	T _A =+25°C	6.0	V
Power Dissipation	P _D	T _A =+70°C Note	533	mW
Operating Ambient Temperature	T _A		-20 to +70	°C
Storage Temperature	T _{stg}		-55 to+150	°C

Note Mounted on double-sided copper-clad 50 × 50 ×1.6 mm epoxy glass PWB

RECOMMENDED OPERATING RANGE

Parameter	Symbol	Test Condition	MIN.	TYP.	MAX.	Unit
Supply Voltage	V _{CC}		4.5	5.0	5.5	V
Operating Ambient Temperature	T _A	V _{cc} = 4.5 to 5.5 V	-20	+25	+70	°C
Gain Control Voltage Range	V _{AGC}		0	-	V _{cc}	V

Preliminary Data Sheet

ELECTRICAL CHARACTERISTICS(T_A=+25°C, V_{CC} = 5V, f = 45MHz, Z_{in} = 50 Ω, Z_{out} (11pin)= 290 Ω, Z_{out} (6,7pin)= 560 Ω)

Parameter	Symbol	Test Conditions	MIN.	TYP.	MAX.	Unit
Input Frequency Range	f _(in)	f _c = -3dB Note 1	30	-	100	MHz
Mode Switch voltage range	V _{SW1}	Digital (QAM) Mode	0	-	1	V
	V _{SW2}	Analog (Video) Mode	3	-	V _{CC}	V
Digital (QAM) Mode V _{SW} =1.0V Z _{L1} =560 Ω						
Circuit Current	I _{CC1}	no input signal Note 1	-	37	48	mA
Maximum Voltage Gain	G _{MAX}	V _{AGC} =2.5V, Dual-IN: V _{ou} =+18dBmV Note 1	27	30	33	dB
Gain Control Range (input prescribe)	GCR _{in}	V _{AGC} =0 to 2.5 V Note 1	35	40	-	dB
3rd Order Inter-modulation Distortion	IM ₃₁	f ₁ = 44 MHz, f ₂ = 45 MHz, V _{in} = +30 dBmV/tone, V _{out} =0.5V _{P-P} /tone Note 1	45	53	-	dBc
Noise Figure	NF ₁	V _{AGC} = 2.5 V f=45MHz Note 2	-	6.0	-	dB
Output Voltage	V _{out1}	f=45MHz , 6pin Note 1	-	1.0	-	V _{P-P}
Output Voltage	V _{out2}	f=45MHz , 7pin Note 1	-	1.0	-	V _{P-P}
AGC Voltage High Level	V _{AGC(H)}	@ Maximum gain Note 1	2.5	-	V _{CC}	V
Analog (Video) Mode V _{SW} =3.0V Z _{L2} =290 Ω						
Circuit Current	I _{CC2}	no input signal Note 1	-	61	79	mA
Pre Amp Voltage Gain	G _V	V _{AGC} =2.5V, Dual-IN: V _{ou} =+18dBmV Note 1	25	28	31	dB
Pre Amp Noise Figure	NF ₂	V _{AGC} = 2.5 V, f=45MHz Note 2	-	6.6	-	dB
3rd Order Inter-modulation Distortion	IM ₃₂	f ₁ = 44 MHz, f ₂ = 45 MHz, P _{in} = -22 dBm/tone, V _{out} =2.5V _{P-P} /tone Note 1	44	58	-	dBc
Output Voltage	V _{out3}	Dual-IN: V _{ou} =+27dBmV, 11pin Note 1	1.3	2.0	2.5	V _{P-P}

Notes 1. By measurement circuit 1

2. By measurement circuit 2

Preliminary Data Sheet

MEASUREMENT CIRCUIT 1

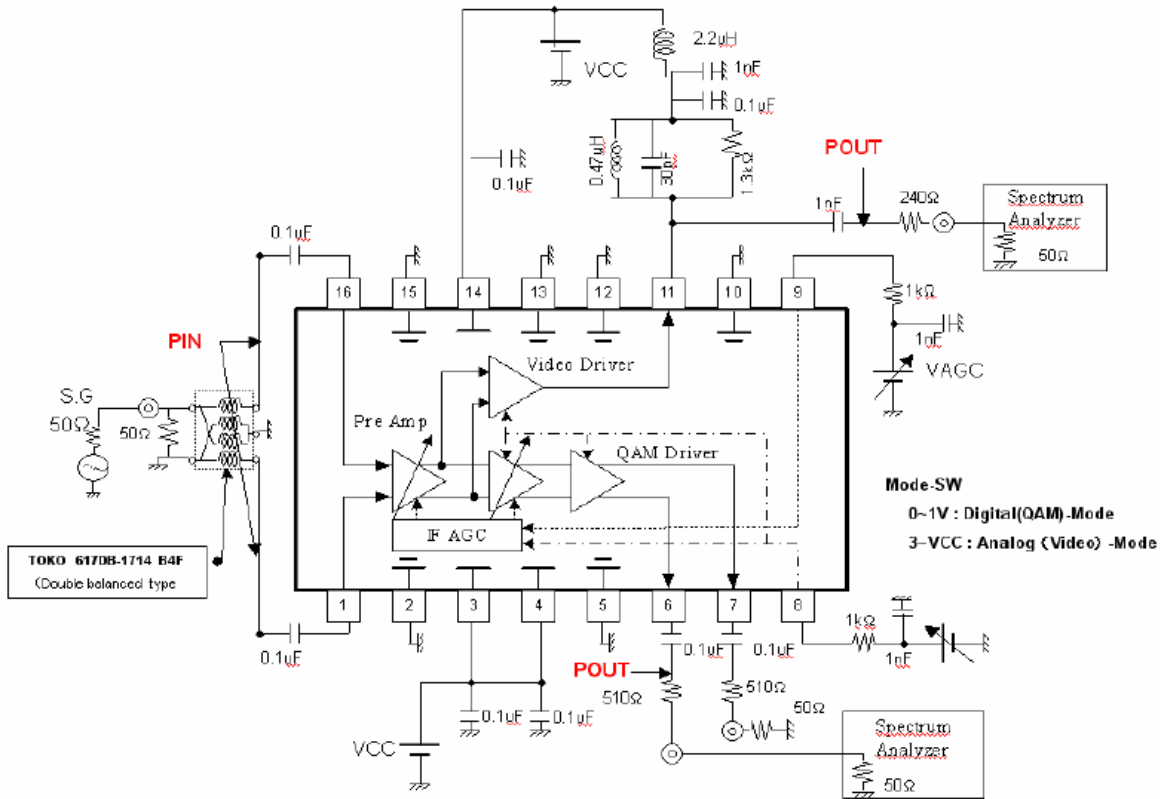

Note Balun Transformer : TOKO 617DB-1714 B4F (Double balanced type)

Preliminary Data Sheet

MEASUREMENT CIRCUIT 2

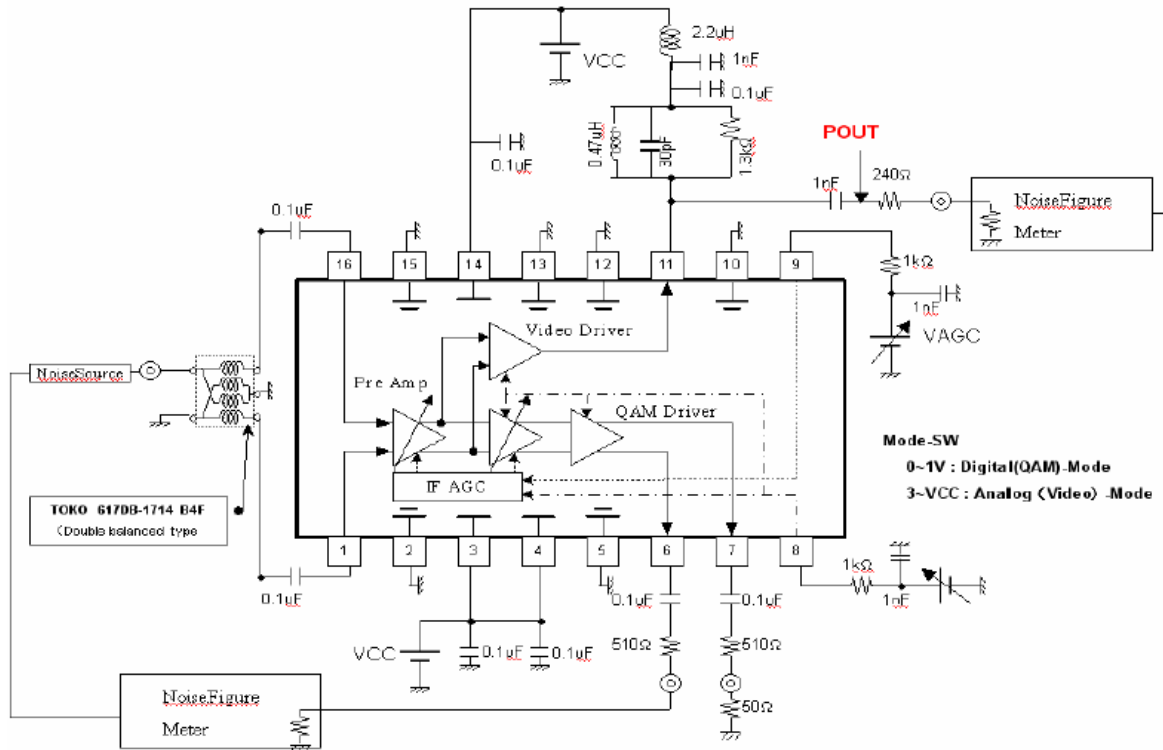

Note Balun Transformer : TOKO 617DB-1714 B4F (Double balanced type)

Preliminary Data Sheet

PACKAGE DIMENSIONS

16 PIN PLASTIC SSOP (5.72mm(225)) (Unit : mm)

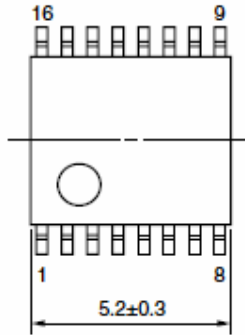

detail of lead end

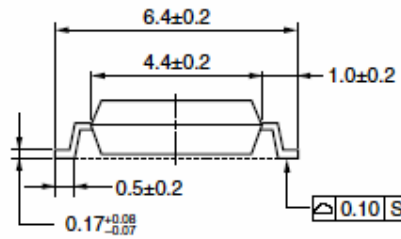
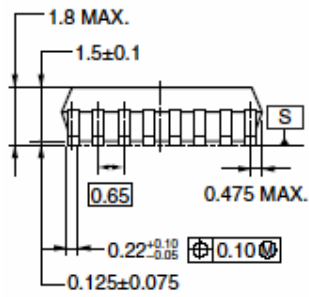

Preliminary Data Sheet

RECOMMENDED SOLDERING CONDITIONS

This product should be soldered and mounted under the following recommended conditions. For soldering methods and conditions other than those recommended below, contact your nearby sales office.

Soldering Method	Soldering Conditions	Condition Symbol
Infrared Reflow	Peak temperature (package surface temperature) : 260°C or below Time at peak temperature : 10 seconds or less Time at temperature of 220°C or higher : 60 seconds or less Preheating time at 120 to 180°C : 120±30 seconds Maximum number of reflow processes : 3 times Maximum chlorine content of rosin flux (% mass) : 0.2%(Wt.) or below	IR260
VPS	Peak temperature (package surface temperature) : 215°C or below Time at temperature of 200°C or higher : 25 to 40 seconds Preheating time at 120 to 150°C : 30 to 60 seconds Maximum number of reflow processes : 3 times Maximum chlorine content of rosin flux (% mass) : 0.2%(Wt.) or below	VP215
Wave Soldering	Peak temperature (molten solder temperature) : 260°C or below Time at peak temperature : 10 seconds or less Preheating temperature (package surface temperature) : 120°C or below Maximum number of flow processes : 1 time Maximum chlorine content of rosin flux (% mass) : 0.2%(Wt.) or below	WS260
Partial Heating	Peak temperature (pin temperature) : 350°C or below Soldering time (per side of device) : 3 seconds or less Maximum chlorine content of rosin flux (% mass) : 0.2%(Wt.) or below	HS350

Caution Do not use different soldering methods together (except for partial heating).

Subject: Compliance with EU Directives

CEL certifies, to its knowledge, that semiconductor and laser products detailed below are compliant with the requirements of European Union (EU) Directive 2002/95/EC Restriction on Use of Hazardous Substances in electrical and electronic equipment (RoHS) and the requirements of EU Directive 2003/11/EC Restriction on Penta and Octa BDE.

CEL Pb-free products have the same base part number with a suffix added. The suffix –A indicates that the device is Pb-free. The –AZ suffix is used to designate devices containing Pb which are exempted from the requirement of RoHS directive (*). In all cases the devices have Pb-free terminals. All devices with these suffixes meet the requirements of the RoHS directive.

This status is based on CEL’s understanding of the EU Directives and knowledge of the materials that go into its products as of the date of disclosure of this information.

Restricted Substance per RoHS	Concentration Limit per RoHS (values are not yet fixed)	Concentration contained in CEL devices	
		-A	-AZ
Lead (Pb)	< 1000 PPM	Not Detected	(*)
Mercury	< 1000 PPM	Not Detected	
Cadmium	< 100 PPM	Not Detected	
Hexavalent Chromium	< 1000 PPM	Not Detected	
PBB	< 1000 PPM	Not Detected	
PBDE	< 1000 PPM	Not Detected	

If you should have any additional questions regarding our devices and compliance to environmental standards, please do not hesitate to contact your local representative.

Important Information and Disclaimer: Information provided by CEL on its website or in other communications concerning the substance content of its products represents knowledge and belief as of the date that it is provided. CEL bases its knowledge and belief on information provided by third parties and makes no representation or warranty as to the accuracy of such information. Efforts are underway to better integrate information from third parties. CEL has taken and continues to take reasonable steps to provide representative and accurate information but may not have conducted destructive testing or chemical analysis on incoming materials and chemicals. CEL and CEL suppliers consider certain information to be proprietary, and thus CAS numbers and other limited information may not be available for release.

In no event shall CEL’s liability arising out of such information exceed the total purchase price of the CEL part(s) at issue sold by CEL to customer on an annual basis.

See CEL Terms and Conditions for additional clarification of warranties and liability.