

FEATURES

Monolithic 10-Bit, 20 MSPS A/D Converter

Low Power Dissipation: 1.0 W

Signal-to-Noise Plus Distortion Ratio

$f_{IN} = 1 \text{ MHz}: 56 \text{ dB}$

$f_{IN} = 10 \text{ MHz}: 54 \text{ dB}$

Guaranteed No Missing Codes

On-Chip Track-and-Hold Amplifier

100 MHz Full Power Bandwidth

High Impedance Reference Input

Out of Range Output

Twos Complement and Binary Output Data

Available in Commercial and Military Temperature Ranges (See Military/Aerospace Reference Manual for Specifications)

PRODUCT DESCRIPTION

The AD773A is a monolithic 10-bit, 20 MspS analog-to-digital converter incorporating an on-board, high performance track-and-hold amplifier (THA). The AD773A converts video bandwidth signals without the use of an external THA. The AD773A implements a multistage differential pipelined architecture with output error correction logic. The AD773A offers accurate performance and guarantees no missing codes over the full operating temperature range.

Output data is presented in binary and twos complement format. An out of range (OTR) signal indicates the analog input voltage is beyond the specified input range. OTR can be decoded with the $\overline{\text{MSB}}/\overline{\text{MSB}}$ pins to signal an underflow or overflow condition. The high impedance reference input allows multiple AD773As to be driven in parallel from a single reference.

The combined dc precision and dynamic performance of the AD773A is useful in a variety of applications. Typical applications include: video enhancement, HDTV, ghost cancellation, ultrasound imaging, radar and high speed data acquisition.

The AD773A was designed using Analog Devices' ABCMOS-1 process which utilizes high speed bipolar and 2-micron CMOS transistors on a single chip. High speed, precision analog circuits are now combined with high density logic circuits. Laser trimmed thin film resistors are used to optimize accuracy and temperature stability.

The AD773A is packaged in a 28-pin ceramic DIP and is available in commercial (0°C to +70°C) and military (-55°C to +125°C) grades.

REV. 0

Information furnished by Analog Devices is believed to be accurate and reliable. However, no responsibility is assumed by Analog Devices for its use, nor for any infringements of patents or other rights of third parties which may result from its use. No license is granted by implication or otherwise under any patent or patent rights of Analog Devices.

FUNCTIONAL BLOCK DIAGRAM

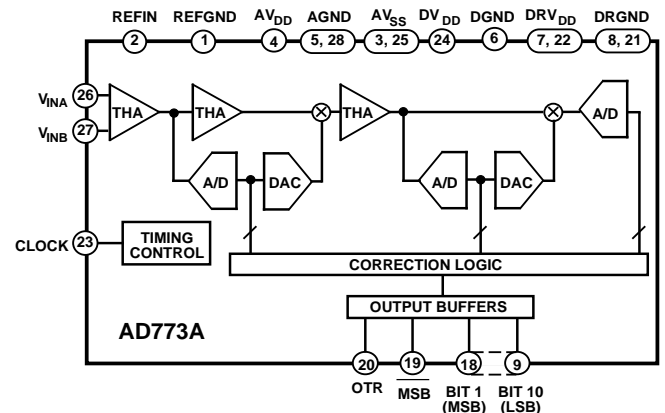

PRODUCT HIGHLIGHTS

1. On-board THA
The high impedance differential input THA eliminates the need for external buffering or sample and hold amplifiers. The THA offers the choice of differential or single-ended inputs. Input current is typically 5 μA .
2. High Impedance Reference Input
The high impedance reference input (200 k Ω) allows direct connection with standard +2.5 V references, such as the AD680, AD580 and REF43.
3. Output Data Flexibility
Output data is available in bipolar offset and bipolar twos complement binary format.
4. Out of Range (OTR)
The OTR output bit indicates when the input signal is beyond the AD773A's input range.
5. Military Temperature Range

AD773A—SPECIFICATIONS

DC SPECIFICATIONS (T_{MIN} to T_{MAX} with AV_{DD} = +5 V ± 5%, AV_{SS} = -5 V ± 5%, DV_{DD} = +5 V ± 5%, DRV_{DD} = +5 V ± 5%, V_{REF} = +2.500 V unless otherwise noted)

Parameter	AD773AJ			AD773AK			Units
	Min	Typ	Max	Min	Typ	Max	
RESOLUTION	10			10			Bits
DC ACCURACY							
Integral Nonlinearity							LSB
T _{MIN} to T _{MAX}		±0.75		±0.75	±2		LSB
Differential Linearity Error							LSB
T _{MIN} to T _{MAX}		±0.75		±0.75	±1		LSB
Zero Error		0.5		0.5	3.5		% FSR
Gain Error		0.5		0.5	3.0		% FSR
No Missing Codes				GUARANTEED			
ANALOG INPUT							
Input Range		1		1			V p-p
Input Current		5	20	5	20		μA
Input Capacitance			10		10		pF
REFERENCE INPUT							
Reference Input Resistance	50	200		50	200		kΩ
Reference Input		2.5			2.5		Volts
LOGIC INPUT							
High Level Input Voltage	+3.5			+3.5			V
Low Level Input Voltage			+0.5			+0.5	V
High Level Input Current (V _{IN} = DV _{DD})	-10		+10	-10		+10	μA
Low Level Input Current (V _{IN} = 0 V)	-10		+10	-10		+10	μA
Input Capacitance		10			10		pF
LOGIC OUTPUTS							
High Level Output Voltage (I _{OH} = 0.5 mA)	+2.4			+2.4			V
Low Level Output Voltage (I _{OL} = 1.6 mA)			+0.4			+0.4	V
POWER SUPPLIES							
Operating Voltages							
AV _{DD}	+4.75		+5.25	+4.75		+5.25	Volts
AV _{SS}	-5.25		-4.75	-5.25		-4.75	Volts
DV _{DD} , DRV _{DD}	+4.75		+5.25	+4.75		+5.25	Volts
Operating Current							
IAV _{DD}		65	80		65	80	mA
IAV _{SS}		-115	-140		-115	-140	mA
IDV _{DD}		10	20		10	20	mA
IDRV _{DD} ¹		10	15		10	15	mA
POWER CONSUMPTION ²		1.0	1.2		1.0	1.2	W
POWER SUPPLY REJECTION		10	18		10	18	mV/V
TEMPERATURE RANGE							
Specified (J/K)	0		+70	0		+70	°C

NOTES

¹C_L = 15 pF.

²100% production tested.

Specifications subject to change without notice. See Definition of Specifications for additional information.

AC SPECIFICATIONS

(T_{MIN} to T_{MAX} with $AV_{DD} = +5\text{ V} \pm 5\%$, $AV_{SS} = -5\text{ V} \pm 5\%$, $DV_{DD} = +5\text{ V} \pm 5\%$, $DRV_{DD} = +5\text{ V} \pm 5\%$, $V_{REF} = +2.500\text{ V}$ unless otherwise noted, $f_{SAMPLE} = 20\text{ MSPS}$, f_{IN} amplitude = -0.5 dB)

Parameter	AD773AJ			AD773AK			Units
	Min	Typ	Max	Min	Typ	Max	
DYNAMIC PERFORMANCE¹							
Signal-to-Noise plus Distortion (S/N+D) Ratio							
$f_{IN} = 1\text{ MHz}$	52	56		54	56		dB
$f_{IN} = 10\text{ MHz}$	50	54		51	54		dB
Effective Number of Bits (ENOB)							
$f_{IN} = 1\text{ MHz}$		9.0			9.0		Bits
$f_{IN} = 10\text{ MHz}$		8.7			8.7		Bits
Total Harmonic Distortion (THD)							
$f_{IN} = 1\text{ MHz}$		-67	-57		-67	-59	dB
$f_{IN} = 10\text{ MHz}$		-65	-54		-65	-55	dB
Spurious Free Dynamic Range ²		70			70		dB
Full Power Bandwidth		100			100		MHz
Intermodulation Distortion (IMD) ³							
Second Order Products		-69			-69		dB
Third Order Products		-64			-64		dB
Differential Phase		0.2			0.2		Degree
Differential Gain		0.5			0.5		%
Transient Response		25			25		ns
Overvoltage Recovery Time		25			25		ns

NOTES

¹For typical dynamic performance curves at $f_{SAMPLE} = 20\text{ Msps}$ see Figures 2 through 7.

² $f_{IN} = 1\text{ MHz}$.

³ $f_a = 1.0\text{ MHz}$, $f_b = 1.05\text{ MHz}$.

Specifications subject to change without notice.

TIMING SPECIFICATIONS

(for all grades T_{MIN} to T_{MAX} with $AV_{DD} = +5\text{ V} \pm 5\%$, $AV_{SS} = -5\text{ V} \pm 5\%$, $DV_{DD} = +5\text{ V} \pm 5\%$, $DRV_{DD} = +5\text{ V} \pm 5\%$, $V_{REF} = +2.500\text{ V}$ unless otherwise noted, $f_{SAMPLE} = 20\text{ MSPS}$)

	Symbol	Min	Typ	Max	Units
Conversion Rate				20	MSPS
Clock Period	t_{CLK}	50			ns
Clock High	t_{CH}	24.5			ns
Clock Low	t_{CL}	24.5			ns
Output Delay	t_{OD}		20		ns
Aperture Delay			7		ns
Aperture Jitter			9		ps
Pipeline Delay (Latency)				4	Clock Cycles

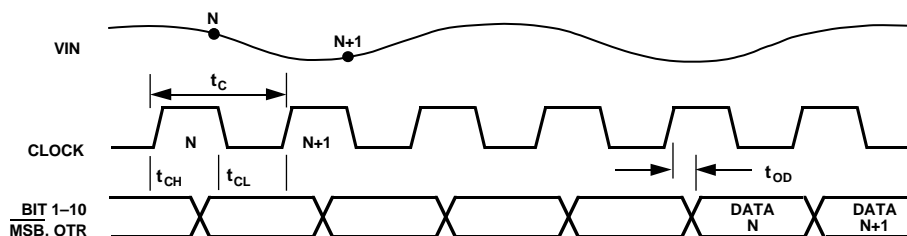

Figure 1. AD773A Timing Diagram

AD773A

ABSOLUTE MAXIMUM RATINGS*

Parameter	With Respect to	Min	Max	Units
V_{DD}	AGND	-0.5	+6.5	V
V_{SS}	AGND	-6.5	+0.5	V
V_{INA}, V_{INB}	AGND	-6.5	+6.5	V
DV_{DD}, DRV_{DD}	DGND, DRGND	-0.5	+6.5	V
AGND	DGND, DRGND	-1.0	+1.0	V
V_{DD}	DV_{DD}, DRV_{DD}	-6.5	+0.5	V
CLK	DV_{DD}, DRV_{DD}	-6.5	+0.5	V
REFIN	REFGND, AGND	-0.5	+6.5	V
Junction Temperature			+150	°C
Storage Temperature		-65	+150	°C
Lead Temperature (10 sec)			+300	°C

*Stresses above those listed under “Absolute Maximum Ratings” may cause permanent damage to the device. This is a stress rating only and functional operation of the device at these or any other conditions above those indicated in the operational sections of this specification is not implied. Exposure to absolute maximum ratings for extended periods may affect device reliability.

PIN CONFIGURATION

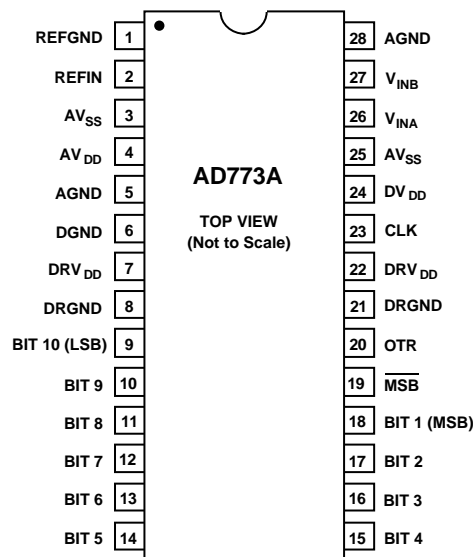

ORDERING GUIDE¹

Model	Temperature Range	Description	Package Option ²
AD773AJD	0°C to +70°C	28-Pin Ceramic DIP	D-28
AD773AKD	0°C to +70°C	28-Pin Ceramic DIP	D-28

NOTES

¹See Military/Aerospace Reference Manual for AD773ASD/883B specifications.
²D = Ceramic DIP.

PIN DESCRIPTION

Symbol	Pin No.	Type	Name and Function
AGND	5, 28	P	Analog Ground.
V_{DD}	4	P	+5 V Analog Supply.
V_{SS}	3, 25	P	-5 V Analog Supply.
MSB	19	DO	Inverted Most Significant Bit. Provides two complement output data format.
OTR	20	DO	Out of Range is Active HIGH on the leading edge of Code 0 or the trailing edge of Code 1023. See Output Data Format Table II.
BIT 1 (MSB)	18	DO	Most Significant Bit.
BIT 2–BIT 9	17–10	DO	Data Bit 2 through Data Bit 9.
BIT 10 (LSB)	9	DO	Least Significant Bit.
CLK	23	DI	Clock Input. The AD773A will initiate a conversion on the falling edge of the clock input. See the Timing Diagram for details.
DV_{DD}	24	P	+5 V Digital Supply.
DRV_{DD}	7, 22	P	+5 V Digital Supply for the output drivers.
DGND	6	P	Digital Ground.
DRGND	8, 21	P	Digital Ground for the output drivers.
REFGND	1	AI	REFGND is connected to the ground of the external reference.
REFIN	2	AI	REFIN is the external 2.5 V reference input, taken with respect to REFGND.
V_{INA}	26	AI	(+) Analog input signal to the differential input THA.
V_{INB}	27	AI	(-) Analog input signal to the differential input THA.

Type: AI = Analog Input; DI = Digital Input; DO = Digital Output; P = Power.

CAUTION

ESD (electrostatic discharge) sensitive device. Electrostatic charges as high as 4000 V readily accumulate on the human body and test equipment and can discharge without detection. Although the AD773A features proprietary ESD protection circuitry, permanent damage may occur on devices subjected to high energy electrostatic discharges. Therefore, proper ESD precautions are recommended to avoid performance degradation or loss of functionality.



INTEGRAL NONLINEARITY (INL)

Linearity error refers to the deviation of each individual code from a line drawn from “zero” through “full scale.” The point used as “zero” occurs 1/2 LSB before the first code transition. “Full scale” is defined as a level 1 1/2 LSB beyond the last code transition. The deviation is measured from the center of each particular code to the true straight line.

DIFFERENTIAL LINEARITY ERROR (DNL, NO MISSING CODES)

An ideal ADC exhibits code transitions that are exactly 1 LSB apart. DNL is the deviation from this ideal value.

ZERO ERROR

The major carry transition should occur for an analog value 1/2 LSB below analog common. Zero error is defined as the deviation of the actual transition from that point.

GAIN ERROR

The first code transition should occur for an analog value 1/2 LSB above nominal negative full scale. The last transition should occur 1 1/2 LSB below the nominal positive full scale. Gain error is the deviation of the actual difference between first and last code transitions and the ideal difference between first and last code transitions.

POWER SUPPLY REJECTION

One of the effects of power supply variation on the performance of the device will be a change in gain error. The specification shows the maximum gain error deviation as the supplies are varied from their nominal values to their specified limits.

SIGNAL-TO-NOISE PLUS DISTORTION (S/N+D) RATIO

S/N+D is the ratio of the rms value of the measured input signal to the rms sum of all other spectral components including harmonics but excluding dc. The value for S/N+D is expressed in decibels.

EFFECTIVE NUMBER OF BITS (ENOB)

ENOB is calculated from the following expression:

$S/N+D = 6.02N + 1.76$, where N is equal to the effective number of bits.

TOTAL HARMONIC DISTORTION (THD)

THD is the ratio of the rms sum of the first six harmonic components to the rms value of the measured input signal and is expressed as a percentage or in decibels.

SPURIOUS FREE DYNAMIC RANGE

The peak spurious or peak harmonic component is the largest spectral component excluding the input signal and dc. This value is expressed in decibels relative to the rms value of a full-scale input signal.

INTERMODULATION DISTORTION (IMD)

With inputs consisting of sine waves at two frequencies, f_a and f_b , any device with nonlinearities will create distortion products, of order $(m+n)$, at sum and difference frequencies of $mf_a \pm nf_b$, where $m, n = 0, 1, 2, 3, \dots$. Intermodulation terms are those for which m or n is not equal to zero. For example, the second order terms are (f_a+f_b) and (f_a-f_b) and the third order terms are $(2f_a+f_b)$, $(2f_a-f_b)$, (f_a+2f_b) and (f_a-2f_b) . The IMD products are expressed as the decibel ratio of the rms sum of the measured input signals to the rms sum of the distortion terms. The two signals are of equal amplitude and the peak value of their sums is -0.5 dB from full scale. The IMD products are normalized to a 0 dB input signal.

DIFFERENTIAL GAIN

The percentage difference between the output amplitudes of a small high frequency sine wave at two stated levels of a low frequency signal on which it is superimposed.

DIFFERENTIAL PHASE

The difference in the output phase of a small high frequency sine wave at two stated levels of a low frequency signal on which it is superimposed.

TRANSIENT RESPONSE

The time required for the AD773A to achieve its rated accuracy after a full-scale step function is applied to its input.

OVERVOLTAGE RECOVERY TIME

The time required for the ADC to recover to full accuracy after an analog input signal 150% of full scale is reduced to 50% of the full-scale value.

APERTURE DELAY

The difference between the switch delay and the analog delay of the THA. This effective delay represents the point in time, relative to the falling edge of the CLOCK input, that the analog input is sampled.

APERTURE JITTER

The variations in aperture delay for successive samples.

PIPELINE DELAY (LATENCY)

The number of clock cycles between conversion initiation and the associated output data being made available. New output data is provided every clock cycle.

FULL POWER BANDWIDTH

The input frequency at which the amplitude of the reconstructed fundamental is reduced by 3 dB for a full-scale input.

AD773A—Dynamic Characteristics

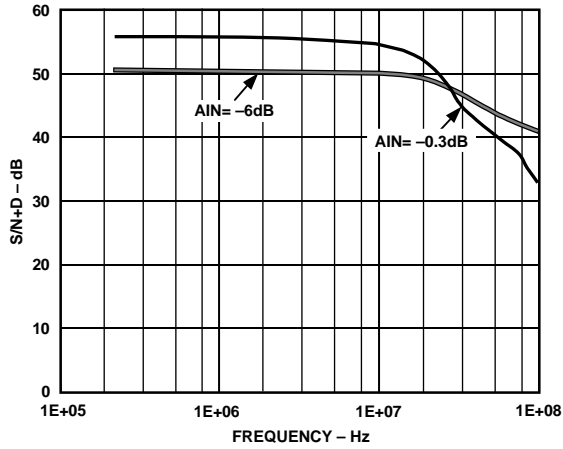

Figure 2. S/N+D vs. Input Frequency, $f_{CLK} = 20$ MSPS

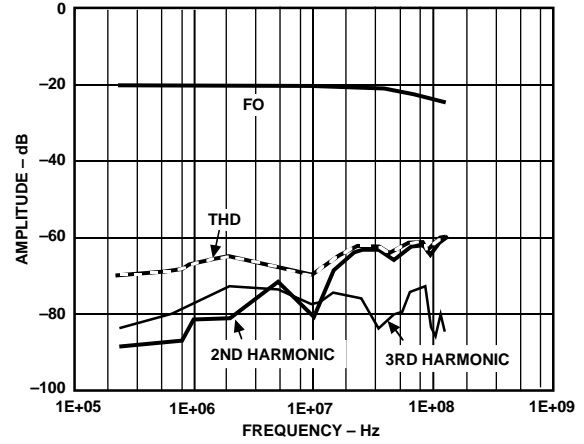

Figure 5. Harmonic Distortion vs. Input Frequency, $f_{CLK} = 20$ MSPS: Small Signal

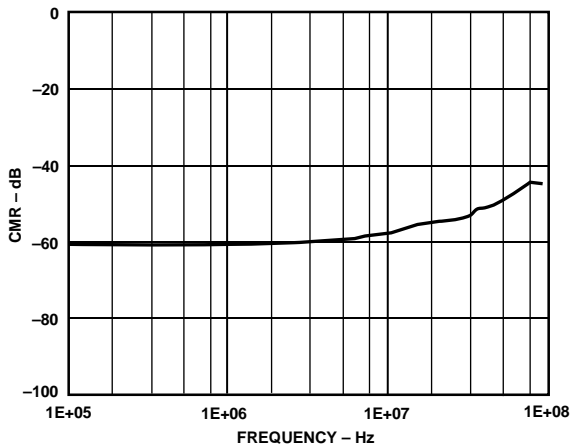

Figure 3. CMR vs. Input Frequency, $f_{CLK} = 20$ MSPS

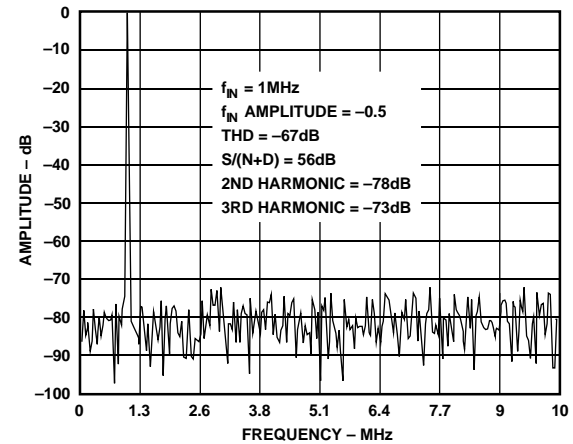

Figure 6. Typical FFT Plot of AD773A, $f_{CLK} = 20$ MSPS, $f_{IN} = 1$ MHz at 1 V p-p

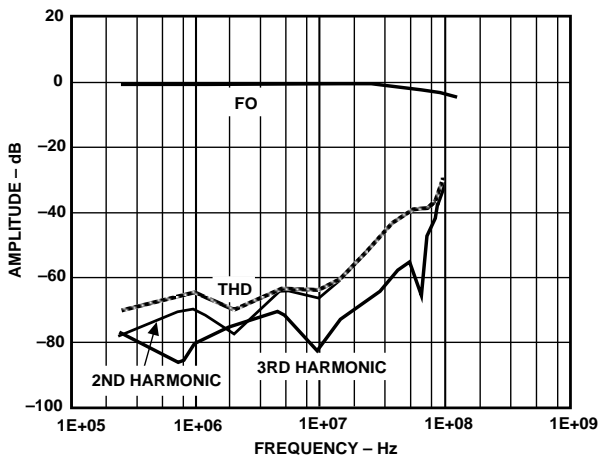

Figure 4. Harmonic Distortion vs. Input Frequency, $f_{CLK} = 20$ MSPS: Full Power

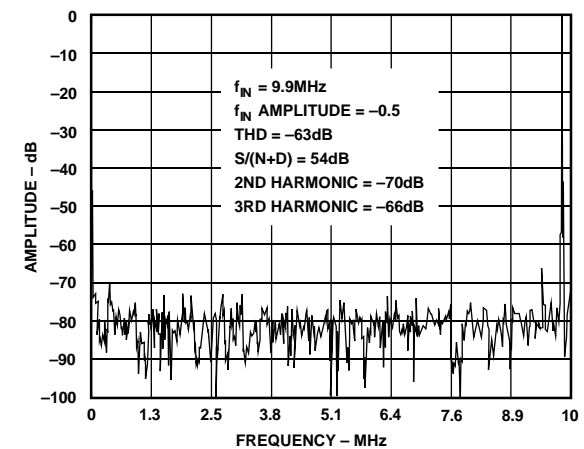

Figure 7. Typical FFT Plot of AD773A, $f_{CLK} = 20$ MSPS, $f_{IN} = 9.9$ MHz at 1 V p-p

Theory of Operation

The AD773A uses a pipelined multistage architecture with a differential input, fast settling track-and-hold amplifier (THA). Traditionally, high speed ADCs have used parallel, or flash architectures. When compared to flash converters, multistage architectures reduce the power dissipation and die size by reducing the number of comparators. For example, the AD773A uses 48 comparators compared to 1023 comparators for a 10-bit flash architecture.

The AD773A's main signal path transmits differential current mode signals. Low impedance current summing techniques are employed, increasing speed by reducing sensitivity to parasitic capacitances. Pipelining allows the stages to operate concurrently and maximizes system throughput.

The input THA is followed by three 4-bit conversion stages. At any given time, the first stage operates on the most recent sample, while the second stage operates on a signal dependent on the previous sample. This process continues throughout all three stages. The twelve digital bits provided by the three 4-bit stages are combined in the correction logic to produce a 10-bit representation of the sampled analog input.

Pipeline delay, or latency, is four clock cycles. New output data is provided every clock cycle and is provided in both binary and twos complement format. The AD773A will flag an out-of-range condition when the analog input exceeds the specified analog input range.

Applying the AD773A

DRIVING THE AD773A INPUT

The AD773A may be driven in a single-ended or differential fashion. V_{INA} is the positive input, and V_{INB} is the negative input. In the single-ended configuration either V_{INA} or V_{INB} is connected to Analog Ground (AGND) while the other input is driven with a full-scale input of ± 500 mV p-p. An inverted mode of operation can be achieved by simply interchanging the input connections.

Both inputs of the AD773A, V_{INA} and V_{INB} , are high impedance and do not need to be driven by a low impedance source. Note, however, that as the source impedance increases, the input node becomes more susceptible to noise. The increased noise at the input will degrade performance. A 10 pF capacitor across V_{INA} and V_{INB} as shown in Figure 8 is recommended to bypass high frequency noise.

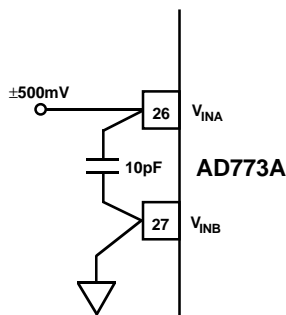

Figure 8. AD773A Single-Ended Input Connection

INPUT CONDITIONING

In some cases, it may be appropriate to buffer the input source, add dc offset, or otherwise condition the input signal of the AD773A. Choosing an appropriate op amp will vary with system requirements and the desired level of performance. Some suggested op amps are the AD9617, AD842, and AD827.

Figure 9 shows a typical application where a unipolar signal is level shifted to the bipolar input range of the AD773A. Note that the reference used with the AD773A can also provide a noise-free voltage source to generate the dc offset.

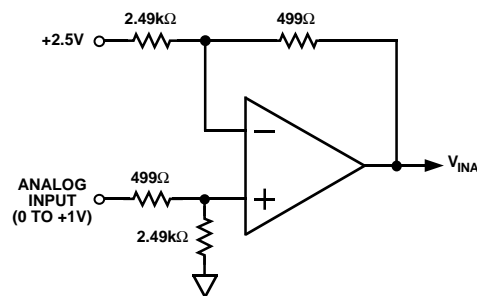

Figure 9. Unipolar to Bipolar Input Connection

DIFFERENTIAL INPUT CONNECTIONS

Operating the AD773A with fully differential inputs offers the advantage of rejecting common-mode signals present on both V_{INA} and V_{INB} . The full-scale input range of V_{INA} and V_{INB} when driven differentially is ± 250 mV p-p as shown in Table I.

Table I. AD773A's Maximum Differential Input Voltage

V_{INA}	V_{INB}	$V_{INA}-V_{INB}$
+250 mV	-250 mV	+500 mV
-250 mV	+250 mV	-500 mV

In some applications it may be desirable to convert a single-ended signal to a differential signal before being applied to the AD773A. Figure 10 shows a single-ended to differential video line driver capable of driving doubly terminated cables.

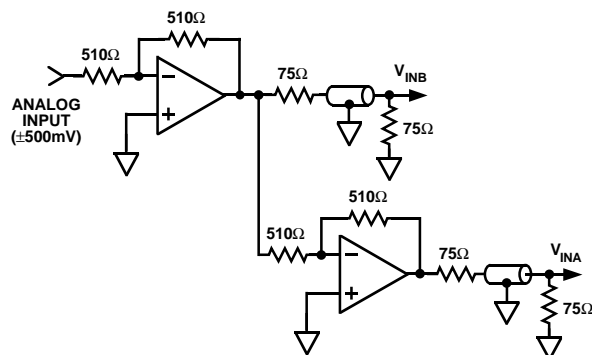

Figure 10. Single-Ended to Differential Connection

AD773A

REFERENCE INPUT

The AD773A's high impedance reference input allows direct connection with standard voltage references. Unlike the resistor ladder requirements of a flash converter the AD773A's single pin, high impedance input can be driven from one low cost, low power reference. The high impedance input allows multiple AD773A's to be driven from one reference thus minimizing drift errors.

Figure 11 shows the AD773A connected to the AD680. The AD680 is a single supply, low power, low cost 2.5 V reference with performance specifications ideally suited for the AD773A. The low pass filter minimizes the AD680's wideband noise. Other recommended 2.5 V references are the AD580 and REF43.

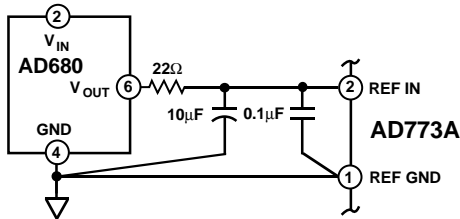

Figure 11. Recommended AD773A to AD680 Connection

CLOCK INPUT

The AD773A's pipelined architecture operates on both the rising and falling edges of the clock input. A low jitter, symmetrical clock will provide the highest level of performance. The recommended logic family to drive the clock input is HC. The AD773A's minimum clock half cycle may necessitate the use of an external divide-by-two circuit as shown in Figure 12. Power dissipation will vary with input clock frequency as shown in Figure 13.

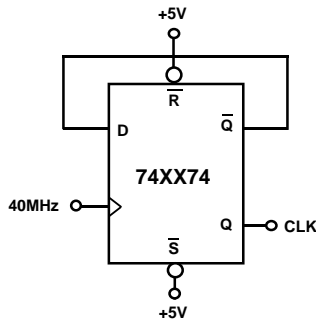

Figure 12. Divide-by-Two Clock Circuit

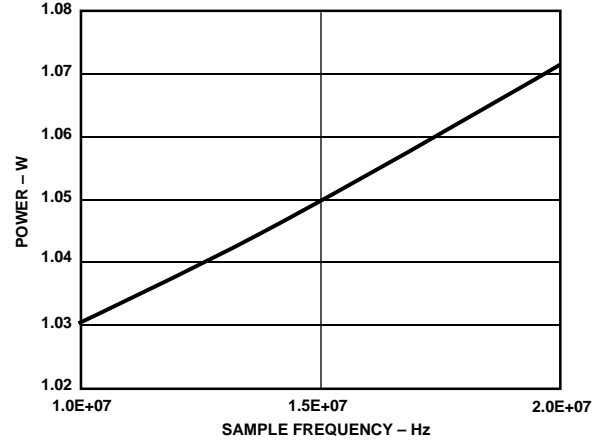

Figure 13. Power Dissipation vs. Sample Frequency

EQUIVALENT ANALOG INPUT CIRCUIT

The AD773A equivalent analog input circuit is shown in Figure 14. The typical input bias current is 5 μA, while input capacitance is typically 5 pF. In the single-ended input configuration one input is connected to AGND while the second input is driven to full scale (±500 mV). Under nominal conditions the collector of the input transistor is at +1.15 V. This allows signals to be offset by up to +0.65 V without significantly degrading performance. In the negative direction, the emitter of the input transistor should not drop below -1.25 V. Therefore, signals can be offset by -0.65 V without significant performance degradation. Figure 15 shows signal-to-noise ratio vs. common-mode input voltage.

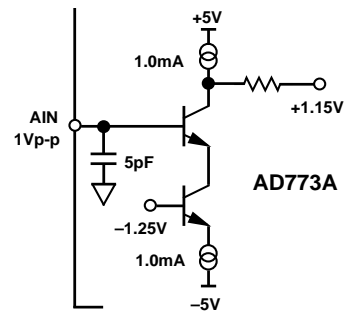

Figure 14. Equivalent Analog Input Circuit

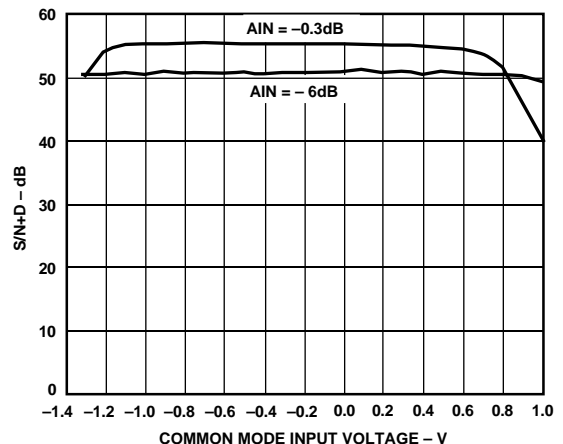

Figure 15. S/N+D vs. Common-Mode Input Voltage, $f_{CLK} = 20$ MSPS

EQUIVALENT REFERENCE INPUT CIRCUIT

The AD773A is designed to have a reference to analog input voltage ratio of 2.5:1. When the AD773A is configured for single-ended operation a 2.5 volt reference input establishes a full-scale analog input voltage of 1 V p-p (± 500 mV with respect to V_{INB}). Although the AD773A is specified and tested with V_{REF} equal to 2.5 V and V_{IN} equal to ± 500 mV the reference input voltage and analog input voltages can be changed. To optimize the AD773A's performance the 2.5:1 ratio should be maintained. The simplified model of the AD773A's reference input circuit is shown in Figure 16.

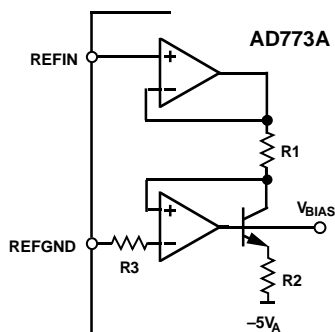

Figure 16. Typical Reference Input Circuit

The 2.5 V external reference is applied across resistor R1 producing a current which in turn generates a voltage V_{BIAS} . Multiple reference currents are generated from V_{BIAS} and are used throughout the converter. R3 is used to cancel errors induced by the input bias current of the REFGND buffer. Figure 17 shows the SNR performance as the reference voltage is varied from its nominal value of 2.5 V. The input full-scale voltage is defined by the following equation,

$$\text{Input Full-Scale Voltage} = \frac{\text{Reference Voltage}}{2.5}$$

The power dissipation is modulated by variations in the reference voltage. Figure 18 shows the variation in power dissipation versus reference voltage.

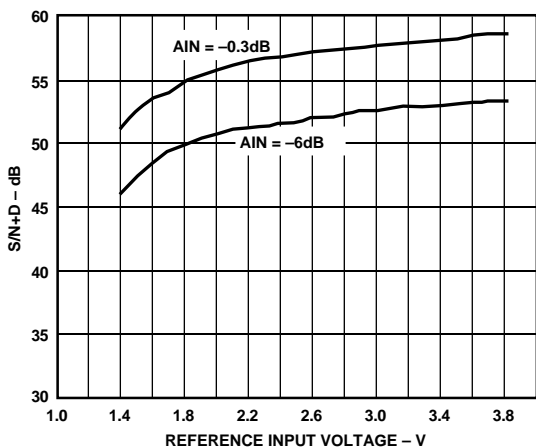

Figure 17. S/N+D vs. Reference Input Voltage, $f_{CLK} = 20$ MSPS, $f_{IN} = 1$ MHz

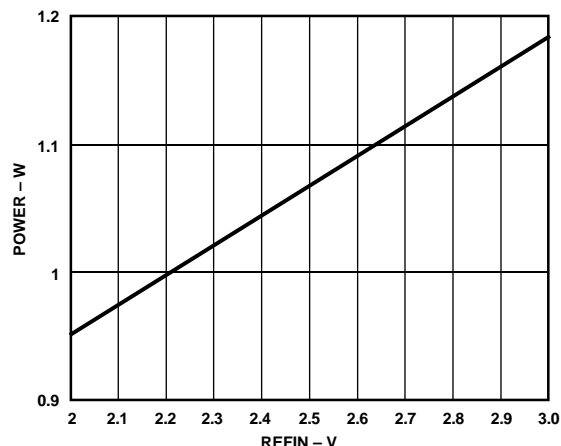

Figure 18. Power Dissipation vs. Reference Input Voltage, $f_{CLK} = 20$ MSPS

TRANSIENT RESPONSE

The fast settling input THA accurately converts full-scale input voltage swings in under one clock cycle. The THA's high impedance, fast slewing performance is critical in multiplexed or dc stepped (charge coupled devices, infrared detectors) systems. Figure 19 shows the AD773A's settling performance with an input signal stepped from -500 mV to 0 V. As can be seen, the output code settles to its final value in under one clock cycle.

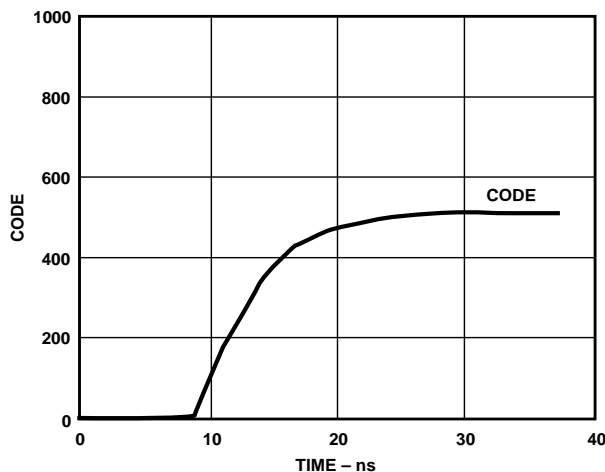

Figure 19. Typical AD773A Settling Time

AD773A

OUTPUT DATA FORMAT

The AD773A provides both MSB and $\overline{\text{MSB}}$ outputs, delivering positive true offset binary and twos complement output data. Table II shows the AD773A's output data format.

Table II. Output Data Format

Analog Input $V_{\text{INA}}-V_{\text{INB}}$	Digital Output		
	Offset Binary	Twos Complement	OTR
≥ 499.5 mV	11 1111 1111	01 1111 1111	1
499 mV	11 1111 1111	01 1111 1111	0
0 mV	10 0000 0000	00 0000 0000	0
-500 mV	00 0000 0000	10 0000 0000	0
≤ -500.5 mV	00 0000 0000	10 0000 0000	1

OUT OF RANGE

An out-of-range condition exists when the analog input voltage is beyond the input range (± 500 mV) of the converter. [Note the AD773A has a 4 clock cycle latency.] OTR (Pin 20) is set low when the analog input voltage is within the analog input range. OTR is set HIGH and will remain HIGH when the analog input voltage exceeds the input range by 1/2 LSB from the center of the \pm full-scale output codes. OTR will remain HIGH until the analog input is within the input range. Note that if the input is driven beyond +1.5 V, the digital outputs may not stay at +FS, but may actually fold back to midscale. By logical ANDing OTR with the MSB and its complement, overrange high or underrange low conditions can be detected. Table III is a truth table for the over/under range circuit in Figure 20. Systems requiring programmable gain conditioning prior to the AD773A can immediately detect an out of range condition, thus eliminating gain selection iterations.

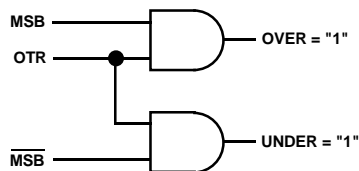

Figure 20. Overrange or Underrange Logic

Table III. Out-of-Range Truth Table

OTR	MSB	ANALOG INPUT IS
0	0	In Range
0	1	In Range
1	0	Underrange
1	1	Overrange

GROUNDING AND LAYOUT RULES

As is the case for any high performance device, proper grounding and layout techniques are essential in achieving optimal performance. (Note—Figures 22–26 are not to scale.) The analog and digital grounds on the AD773A have been separated to optimize the management of return currents in a system. It is recommended that a 4-layer printed circuit board (PCB) which employs ground planes and power planes be used with the AD773A. The use of ground and power planes offers distinct advantages:

1. The minimization of the loop area encompassed by a signal and its return path.
2. The minimization of the impedance associated with ground and power paths.
3. The inherent distributed capacitor formed by the power plane, PCB insulation, and ground plane.

These characteristics result in both a reduction of electromagnetic interference (EMI) and an overall improvement in performance.

It is important to design a layout which prevents noise from coupling onto the input signal. The wide input bandwidth of the AD773A permits noise outside the desired Nyquist bandwidth to be sampled along with the desired signal. This can result in a higher overall level of spurious noise in the digitized output. Digital signals should not be run in parallel with the circuitry. It is also suggested that the traces associated with V_{INA} and V_{INB} be the same length.

Separate analog and digital grounds should be joined together directly under the AD773A (see Figure 24). A solid ground plane under the AD773A is also acceptable if care is taken in the management of the power and ground return currents. A general “rule-of-thumb” for mixed signal layouts dictates that the return currents from digital circuitry should not pass through critical analog circuitry.

POWER SUPPLY DECOUPLING

The analog and digital supplies of the AD773A have been separated to prevent the typically large transients associated with digital circuitry from coupling into the analog supplies (AV_{DD} , AV_{SS}). Each analog power supply pin should be decoupled with a 0.1 μF capacitor located as close to the pin as possible. Additionally, 0.22 μF capacitors for the DRV_{DD} and DV_{DD} supplies are required to adequately suppress high frequency noise. For optimal performance, surface-mount capacitors are recommended. The inductance associated with the leads of through-hole ceramic capacitors typically render them ineffective at higher frequencies. A *complete* system will also incorporate tantalum capacitors in the 10–100 μF range to decouple low frequency noise and ferrite beads to limit high frequency noise.

The digital supplies have also been separated into DRV_{DD} and DV_{DD} . The DRV_{DD} pins provide power for the digital output drivers of the AD773A and are likely to contain high energy transients. Pin 22 should be decoupled directly to Pin 21 (DRGND) and Pin 7 should be decoupled directly to Pin 8 (DRGND) to minimize the length of the return path for these transients. A single +5 V supply is all that is required for DRV_{DD} and DV_{DD} , but decoupling DV_{DD} with an RC filter network is suggested (see Figure 21).

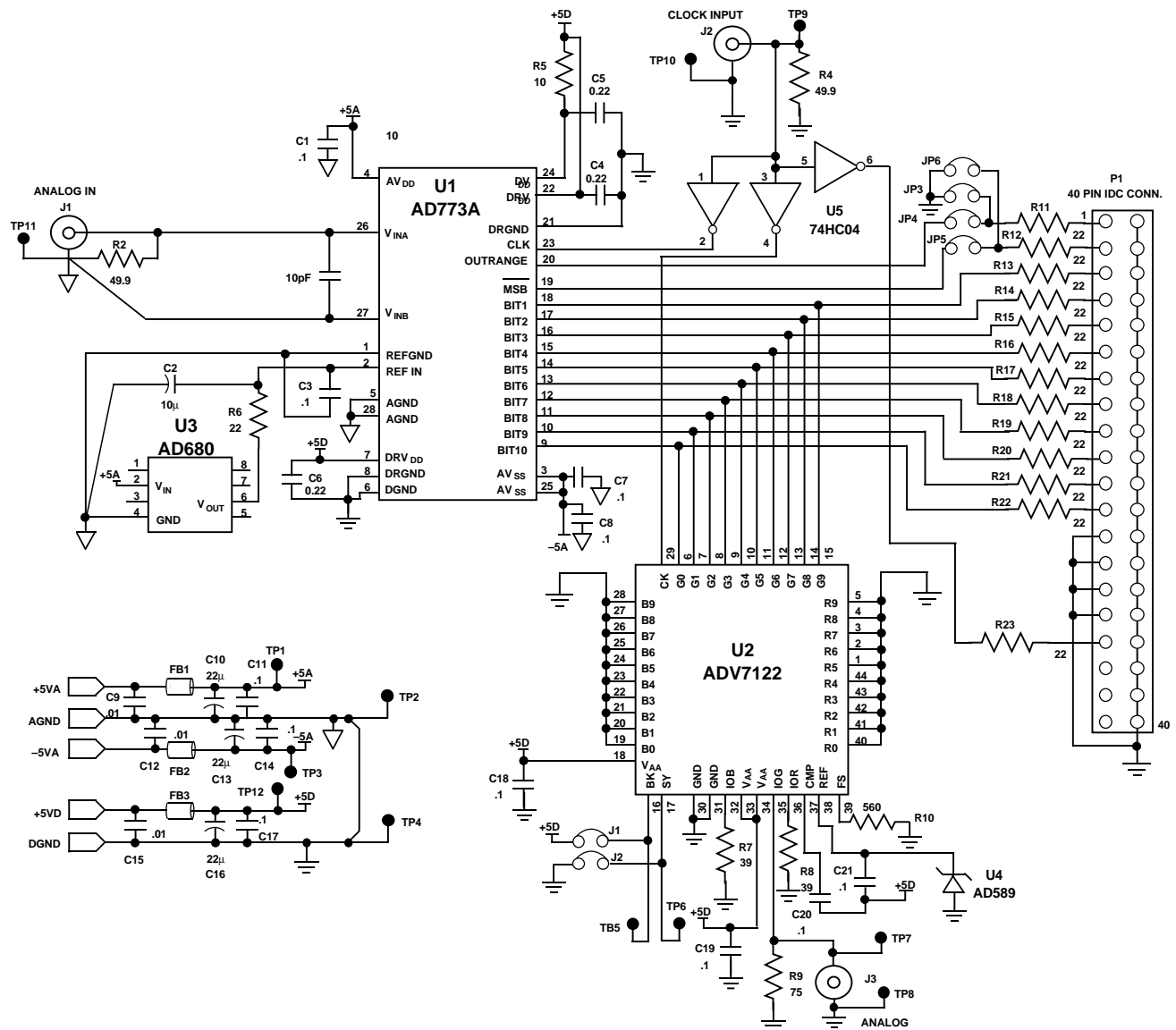

Figure 21. AD773A Evaluation Board Schematic

Table IV. Components List

Reference Designator	Description	Quantity
R2, R4	Resistor, 1%, 49.9 Ω	2
R5, R6, R11–R22	Resistor, 5%, 22 Ω	14
R7, R8	Resistor, 5%, 39 Ω	2
R9	Resistor, 5%, 75 Ω	1
R10	Resistor, 5%, 560 Ω	1
C1, C3–C8, C11, C14, C17–C21	Chip Cap, 0.1 μF	14
C2	Capacitor, Tantalum, 10 μF	1
C9, C12, C15	Chip Cap, 0.01 μF	3
C10, C13, C16	Capacitor, Tantalum, 22 μF	3
U1	AD773A	1
U2	ADV7122	1
U3	AD680	1
U4	AD589	1
U5	74AS04	1
FB1–FB3	Ferrite Bead	3

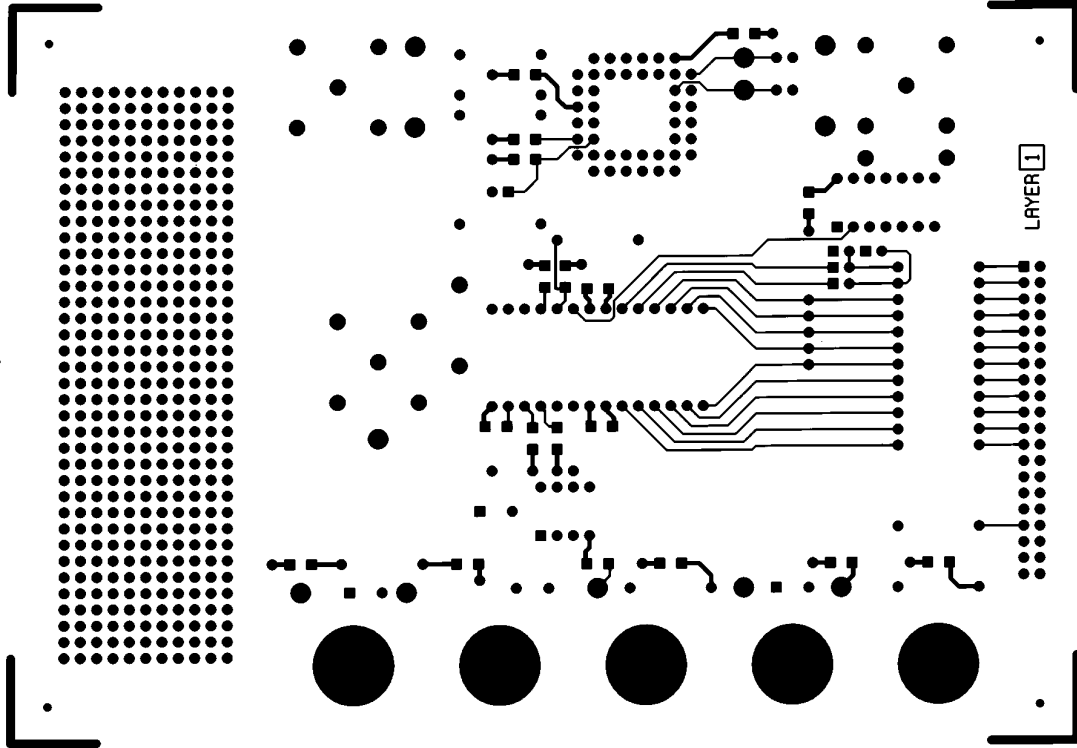

Figure 22. Component Side PCB Layout

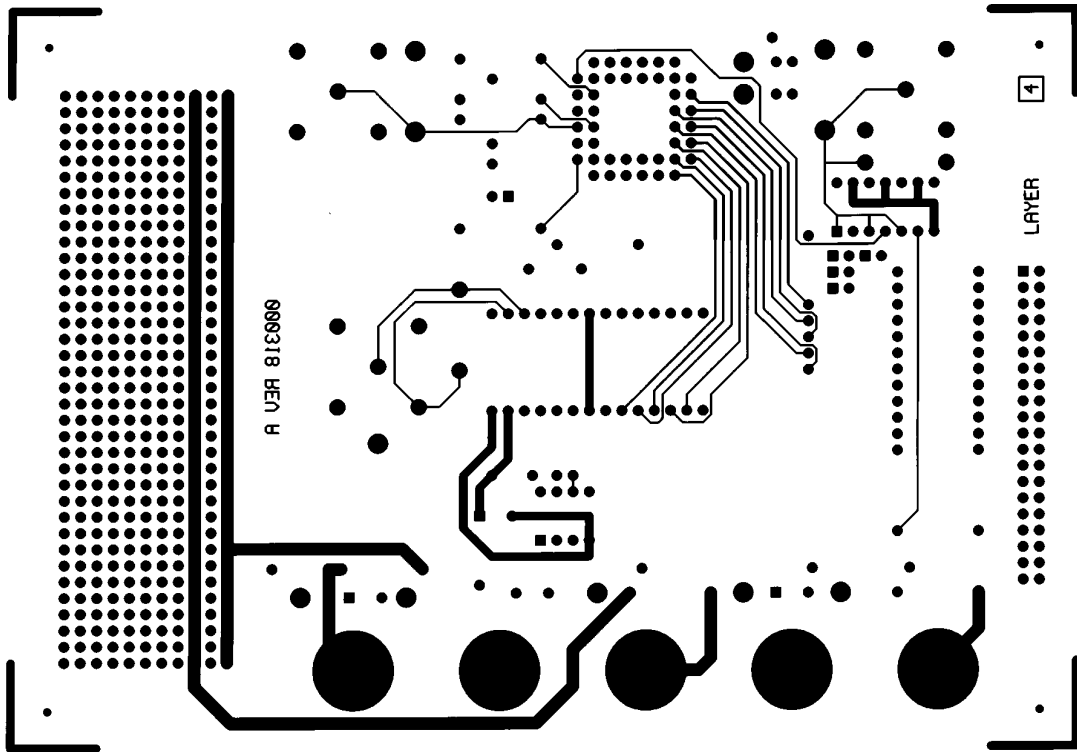

Figure 23. Solder Side PCB Layout

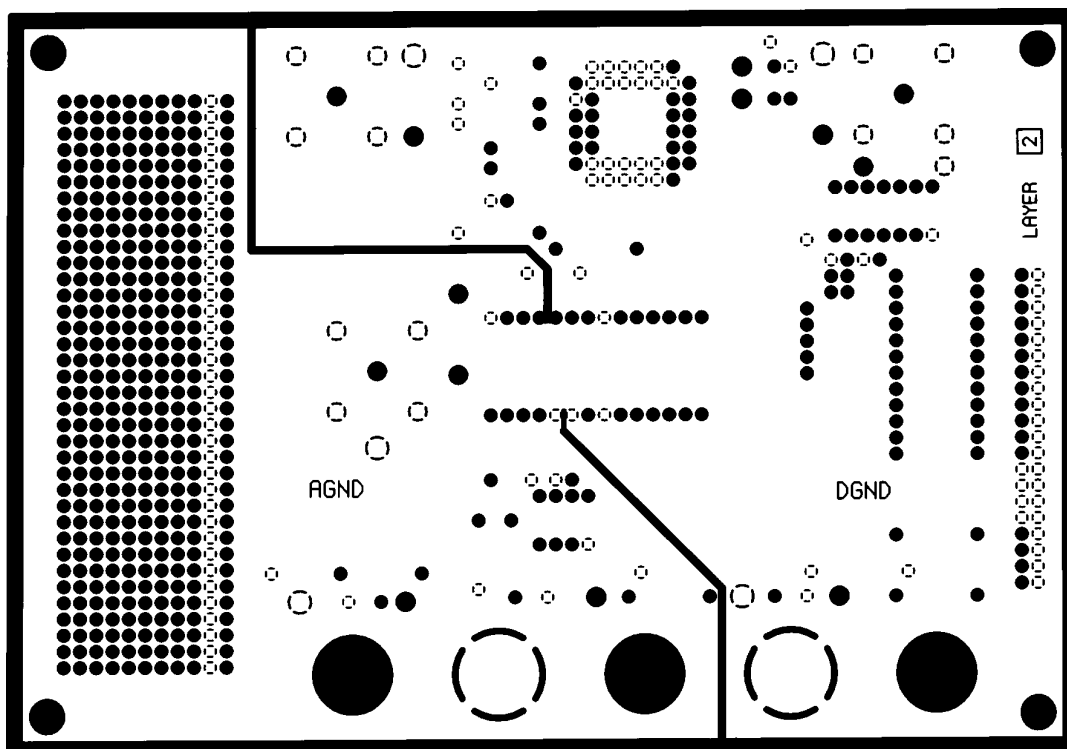

Figure 24. Ground Layer PCB Layout

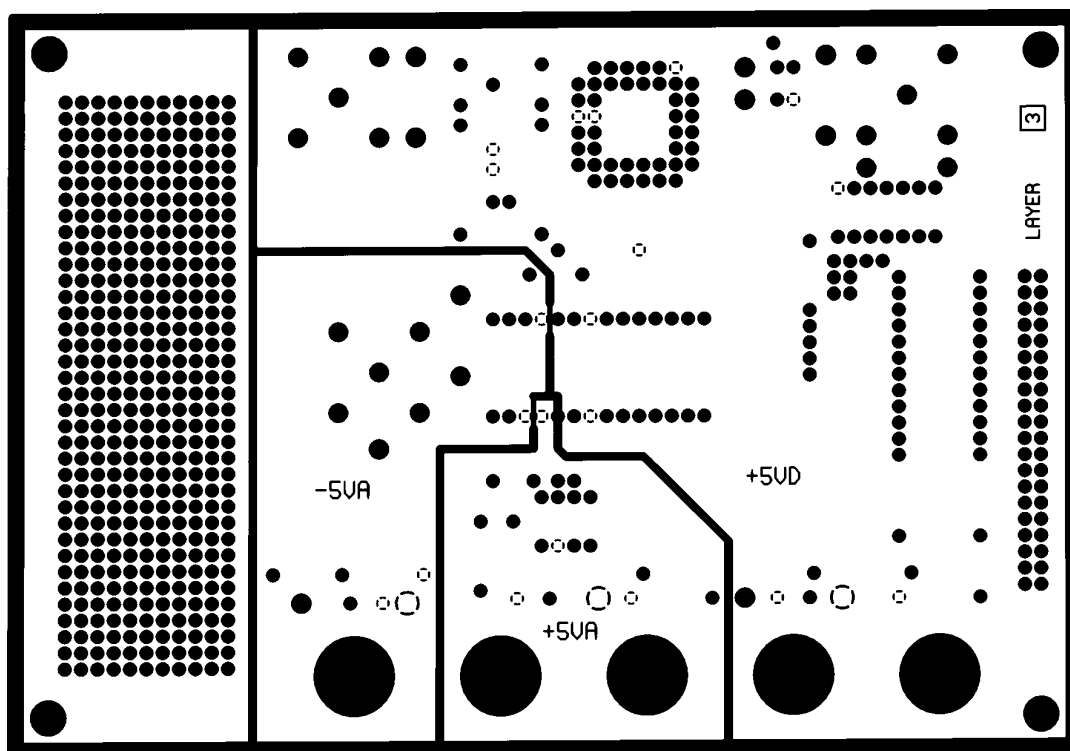

Figure 25. Power Layer PCB Layout

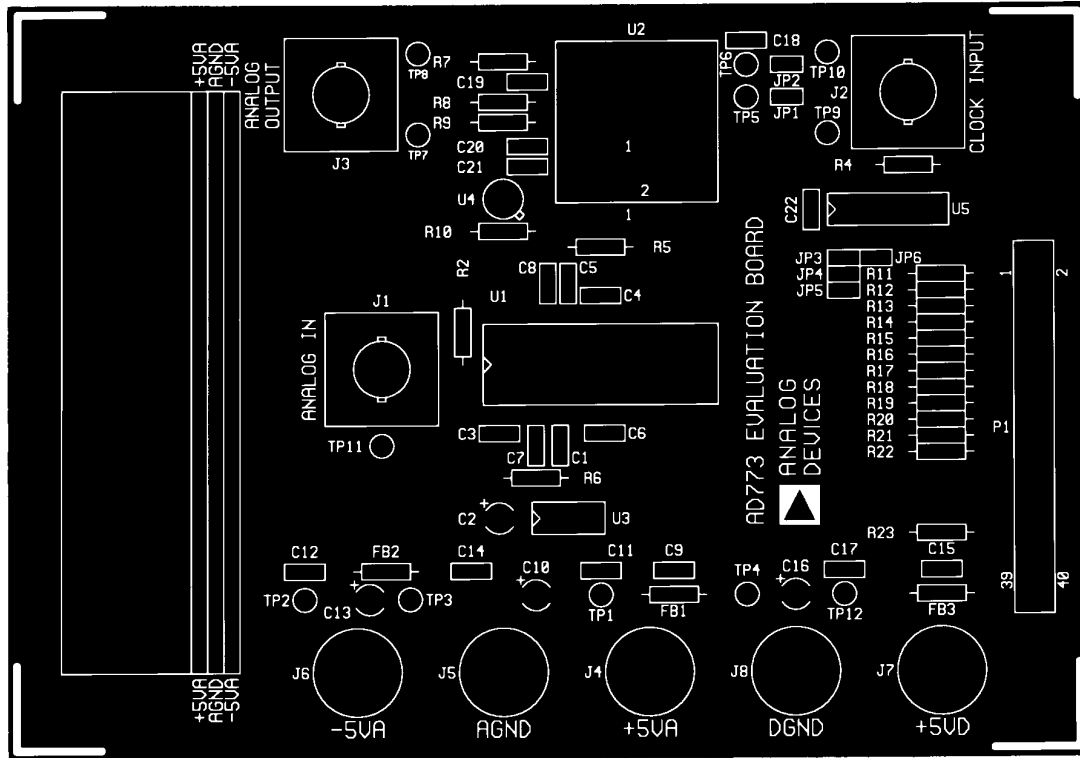

Figure 26. Silkscreen Layer PCB Layout

OUTLINE DIMENSIONS

Dimensions shown in inches and (mm).

28-Pin Ceramic DIP Package (D-28)

