

Rad-Hard, Dual, Adjustable, Negative & Positive, Linear Voltage Regulator

DEVICES

MHL127A Series

LEVELS AVAILABLE

FEATURES

- Rad-Hard to 300Krad TID¹
- Single Event, latch-up immune (LET = 87MeV/mg/cm²)¹
- Wide Input Voltage Range: +4.25V to +35V, -3.25V to -25V
- COTS & Class K-level screening available

DESCRIPTION:

The MHL127A Series is a wide-input range, dual linear regulator designed for military and space flight applications. Packaged in a hermetic, 8-Pin package, the MHL127 provides ±1.0A of output current over the full input voltage range of +4.25V to +35V, -3.25V to -25V. The device also features internal thermal shutdown and output current-limiting circuitry. The MHL127A Series is intended for general purpose Op-Amps and Log-Amps with dual supply rails. This dual linear regulator makes an excellent choice for applications requiring high radiation tolerance & low noise.

The MHL127A Series is provided in adjustable output voltage configuration. Only two resistors are required to program the output voltage.

Table 1 – ABSOLUTE MAXIMUM RATINGS (*Exceeding maximum ratings may damage the device*)

Parameters / Test Conditions	Symbol	Value	Unit
DC Input Voltage	V _{in}	+35, -25	V
Output Current	I _o	±1.0	A
Power Dissipation T _{case} =25deg.C	P _d	40	W
Thermal Resistance, Junction to Case	R _{thjc}	3.0	°C/W
Storage Temperature	T _{stg}	-65 to +150	°C
Operating Temperature Range	T _{op}	-55 to +125	°C
Maximum Junction Temperature	T _j	150	°C
Package weight	W	7	g
Maximum Soldering Temperature, 10sec	T _{sold}	300	°C

RADIATION RATING

Parameters / Test Conditions	Symbol	Value	Unit
Maximum Total Dose (Dose Rate: 50-300 rad(Si)/s)	TID	300	Krads (Si)
Linear Energy Threshold, Single Event Transients < 100mV,	SET	15	MeV/mg/cm ²
Single-Event Latch-up linear Energy threshold	SEL	87	MeV/mg/cm ²

ELECTRICAL CHARACTERISTICS @ $T_A = -55^{\circ}\text{C}$ to $+125^{\circ}\text{C}$
(Unless otherwise specified)

Parameters / Test Conditions	Symbol	Min.	Typ	Max.	Unit
Positive Reference Voltage accuracy $V_{\text{diff}} = 3.0\text{V}$, $I_L = 10\text{ mA}$, $T_A = 25^{\circ}\text{C}$	V_{REF}	1.225		1.275	V
Negative Reference Voltage accuracy $V_{\text{diff}} = 23\text{V}$, $I_L = 3\text{mA}$, $T_A = 25^{\circ}\text{C}$	V_{REF}	-1.300		-1.200	V
Input Voltage Range + $I_{\text{out}} = 1.0\text{A}$	$V_{\text{IN}+}$	+4.25		+35	V
Input Voltage Range - $I_{\text{out}} = 1.0\text{A}$	$V_{\text{IN}-}$	-25		-3.25	V
Line Regulation (Note 2) $V_{\text{ref}} = V_{\text{out}} - V_{\text{adj}}$ $V_{\text{in}} = 4.25\text{V}$ to 35V $I_L = 10\text{ mA}$	$V_{\text{LINE}+}$			27	mV
Line Regulation (Note 2) $V_{\text{ref}} = V_{\text{out}} - V_{\text{adj}}$ $V_{\text{in}} = -3.25\text{V}$ to -25V $I_L = 10\text{ mA}$	$V_{\text{LINE}-}$			27	mV
Load Regulation (Note 2) $V_{\text{diff}} = 3\text{V}$, $10\text{mA} \leq I_L \leq 1.0\text{A}$	$V_{\text{load}+}$			15	mV
Load Regulation (Note 2) $V_{\text{diff}} = 3\text{V}$, $3\text{mA} \leq I_L \leq 1.0\text{A}$	$V_{\text{load}-}$			15	mV
Adjust-pin current $V_{\text{diff}} = 3\text{V}$, $10\text{mA} \leq I_L \leq 5.5\text{mA}$	I_{adj}			100	μA
Short-circuit Current $V_{\text{diff}} = 10\text{V}$	$I_{\text{cl}+}$	1.5			A
Short-circuit Current $V_{\text{diff}} = 10\text{V}$	$I_{\text{cl}-}$	-		-1.5	A

NOTE:

- (1) At the time of publication of this preliminary datasheet, Microsemi does not have a DLA certified radiation hardness assurance program.
- (2) Load & Line regulation are measured at constant (T_j) junction temperature using a low duty cycle pulse. Changes in output voltage due to heating effects must be evaluated separately.

APPLICATION CIRCUIT

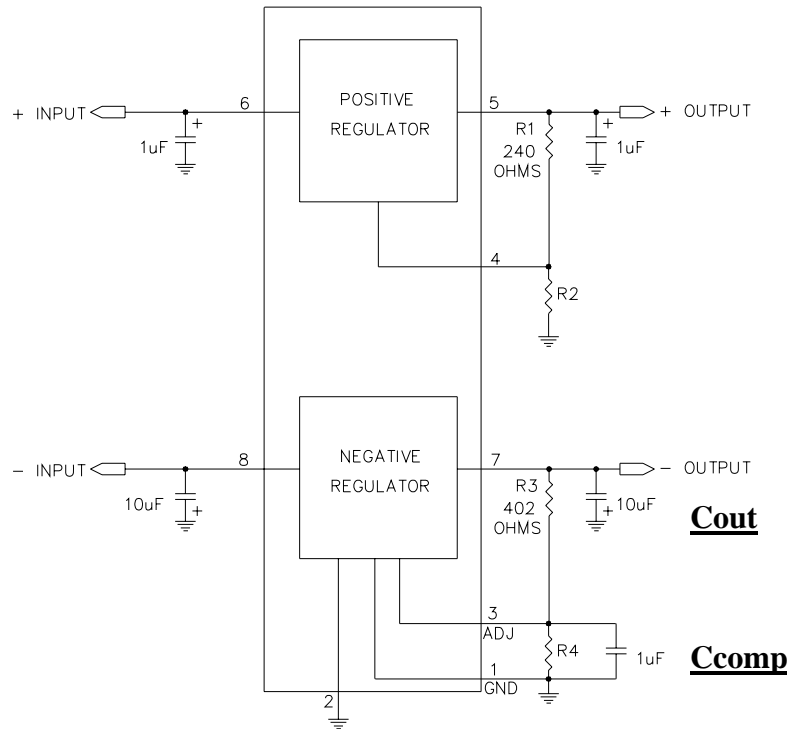

FIGURE 1- Typical application circuit

$$+V_{out} = 1.25 (1 + R2/R1)$$

$$-V_{out} = 1.25 (1 + R4/R3)$$

$$C_{comp} \geq [C_{out} * ESR (C_{out})] / R3$$

PIN DESCRIPTION

* PIN ASSIGNMENT

PIN #	PIN NAME	PIN DESCRIPTION
1	-GND	Ground
2	-SHDN	Negative Shutdown
3	-ADJ	Negative Adjust PIN
4	+ADJ	Positive Adjust PIN
5	+VOUT	Positive Output Voltage
6	+VIN	Positive Input Voltage
7	-VOUT	Negative Output Voltage
8	-VIN	Negative Input Voltage

6 Lake Street, Lawrence, MA 01841
 1-800-446-1158 / (978) 620-2600 / Fax: (978) 689-0803
 Website: <http://www.microsemi.com>

PACKAGE OUTLINE- 8-Pin

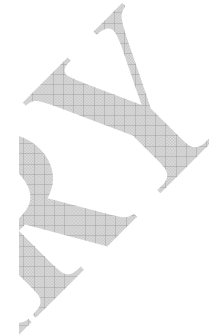
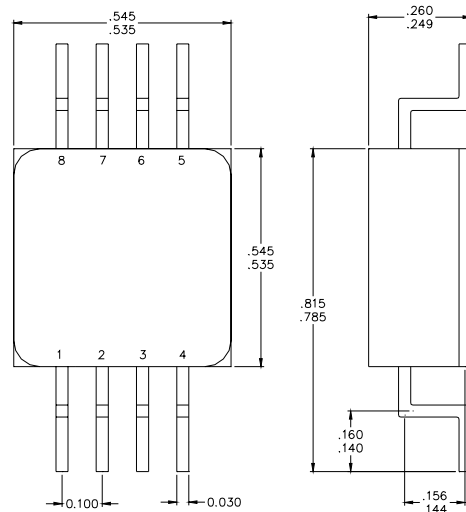

ORDERING INFORMATION:

MHL127A

K

1

C = Cots
 K = Class K

1 = None
 2 = SMT (as shown)

