

TOSHIBA BIPOLAR LINEAR INTEGRATED CIRCUIT SILICON MONOLITHIC

# TA8889AP

## RGB CUT OFF DRIVE CONTROL IC

The TA8889AP is 16pin DIP package IC which has RGB Cut off/Drive control circuit.

The feature of TA8889AP is controlled via via I<sup>2</sup>C bus.

### FEATURES

- 3 independents cut off control for 3 primary color.
- Independent drive control for blue and green color.
- 0dB / 6dB gain SW
- I<sup>2</sup>C bus interface circuit

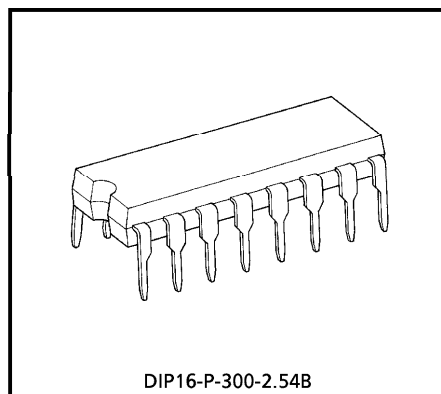

DIP16-P-300-2.54B

Weight : 1.11g (Typ.)

### BLOCK DIAGRAM

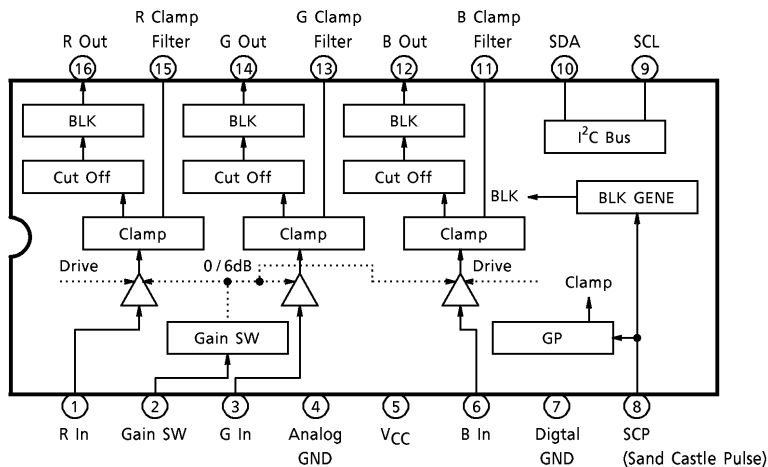

961001EBA2

- TOSHIBA is continually working to improve the quality and the reliability of its products. Nevertheless, semiconductor devices in general can malfunction or fail due to their inherent electrical sensitivity and vulnerability to physical stress. It is the responsibility of the buyer, when utilizing TOSHIBA products, to observe standards of safety, and to avoid situations in which a malfunction or failure of a TOSHIBA product could cause loss of human life, bodily injury or damage to property. In developing your designs, please ensure that TOSHIBA products are used within specified operating ranges as set forth in the most recent products specifications. Also, please keep in mind the precautions and conditions set forth in the TOSHIBA Semiconductor Reliability Handbook.
- The products described in this document are subject to foreign exchange and foreign trade control laws.
- The information contained herein is presented only as a guide for the applications of our products. No responsibility is assumed by TOSHIBA CORPORATION for any infringements of intellectual property or other rights of the third parties which may result from its use. No license is granted by implication or otherwise under any intellectual property or other rights of TOSHIBA CORPORATION or others.
- The information contained herein is subject to change without notice.

TERMINAL FUNCTION

PIN No.	PIN NAME	FUNCTION	INTERFACE CIRCUIT
1 3 6	R In G In B In	These are primary color input terminals. The signal which pedestal DC level is 2V should be inputted.	
2	Gain SW	This is the switch terminal for gain 0dB / 6dB and blanking pulse. Please refer gain SW mode table for detail.	
4	Analog GND	This is the GND terminal for analog circuit.	—
5	VCC	This is common VCC terminal for analog and digital circuit. The coupling capacitor should be connected between this terminal and digital GND.	—
7	Digital GND	This is GND terminal for I <sup>2</sup> L circuit. The coupling capacitor should be connected between this terminal and digital GND.	—
8	S.C.P.	This is S.C.P. input terminal. The threshold level of clamp pulse is 6.5V and more (typ.), that of blanking pulse is 1.5V and less (typ.).	
9	SCL	This is SCL terminal for I <sup>2</sup> C bus. Because its is week for surge impulse, connect external devices for protection against surge if necessary.	

PIN No.	PIN NAME	FUNCTION	INTERFACE CIRCUIT
10	SDA	This is SDA terminal for I <sup>2</sup> C bus. Because its is week for surge impulse, connect external devices for protection against surge if necessary.	
15 13 11	R Clamp Filter G Clamp Filter B Clamp Filter	This is the clamp filter terminal for R /G /B signal which is the signal after cut off and drive circuit.	
16 14 12	R Out G Out B Out	This is the R /G /B signal output terminal. We recommend its connects L.P.F. for removing high frequency noise.	

**TERMINAL 2 (GAIN SW) OUTPUT MODE TABLE**

(V<sub>CC</sub> = 12V, Ta = ±3°C)

TERMINAL VOLTAGE	GAIN	BLANKING
V <sub>CC</sub> (9.7V~V <sub>CC</sub> )	6dB	Available
7.5V (6.7V~8.3V)		Not available
4.5V (3.7V~5.3V)	0dB	
GND (GND~2.3V)		

**I<sup>2</sup>C BUS CONTROL MAP**

- Slave address : 10011000 (98H)
- Sub address

SUB ADDRESS		7	6	5	4	3	2	1	0	PRESET	
00	( I )	Red color cut off control (10bit)								LSB	00000000 (00H)
01	(II)	x	x	x	x	x	x	MSB ↑		00000000 (00H)	
02	( I )	Green color cut off control (10bit)								LSB	00000000 (00H)
03	(II)	x	x	x	x	x	x	MSB ↑		00000000 (00H)	
04	( I )	Blue color cut off control (10bit)								LSB	00000000 (00H)
05	(II)	x	x	x	x	x	x	MSB ↑		00000000 (00H)	
06	(III)	MSB	Red color drive control (8bit)						LSB	00000000 (00H)	
07	(III)	MSB	Blue color drive control (8bit)						LSB	00000000 (00H)	

(Note) x bit : don't care

**I<sup>2</sup>C BUS CONTROLLED FORMAT SUMMARY**

Bus controlled format of TA8889AP is based on I<sup>2</sup>C bus control format of Philips.

Data transfer format

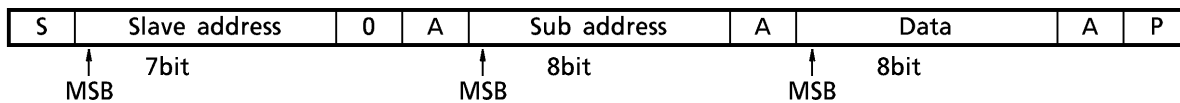

S : Start Condition

P : Stop Condition

A : Acknowledge

**(1) Start and stop condition**

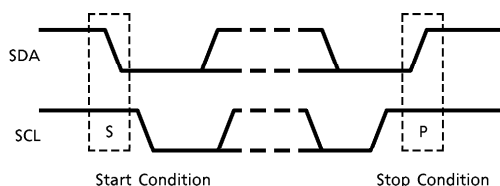

**(2) Bit transfer**

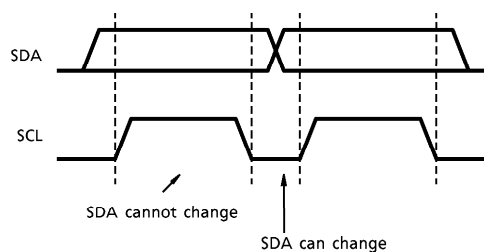

**(3) Acknowledge**

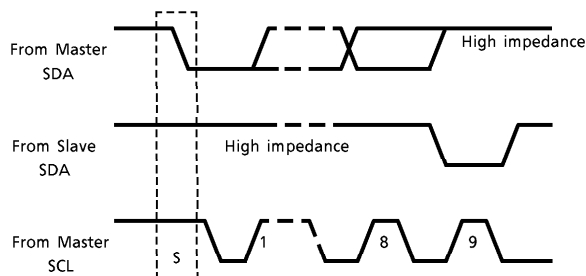

**(4) Slave address**

A6	A5	A4	A3	A2	A1	A0	R / $\bar{W}$
1	0	0	1	1	0	0	0

Purchase of TOSHIBA I<sup>2</sup>C components conveys a license under the Philips I<sup>2</sup>C Patent Rights to use these components in an I<sup>2</sup>C system, provided that the system conforms to the I<sup>2</sup>C Standard Specification as defined by Philips.

**MAXIMUM RATINGS** ( $T_a = 25^\circ\text{C} \pm 3^\circ\text{C}$ )

CHARACTERISTIC	SYMBOL	RATING	UNIT
Power Supply Voltage	$V_{CC}$	15	V
Power Dissipation	$P_D$ (Note 1)	1.4	W
Input Signal Voltage	$e_{in}$	7	$V_{p-p}$
Terminal Voltage	$V_{in}$ (Note 2)	$\text{GND} - 0.3 \sim V_{CC} + 0.3$	V
Operating Temperature	$T_{opr}$	$-20 \sim 65$	$^\circ\text{C}$
Storage Temperature	$T_{stg}$	$-65 \sim 150$	$^\circ\text{C}$

(Note 1) When using the device at above  $T_a = 25^\circ\text{C}$ , decrease the power dissipation by 11.2mW for each increase of  $1^\circ\text{C}$ .

(Note 2) Rating of pin 9 and 10 is  $\text{GND} - 0.3\text{V} \sim 5.5\text{V}$ .

**RECOMMENDED SUPPLY VOLTAGE**

PIN No.	PIN NAME	MIN.	TYP.	MAX.	UNIT
5	$V_{CC}$	10.8	12.0	13.2	V

**ELECTRICAL CHARACTERISTICS**

DC characteristics (Unless otherwise specified,  $V_{CC} = 12\text{V}$ ,  $T_a = 25 \pm 3^\circ\text{C}$ )

CHARACTERISTIC	SYMBOL	TEST CIRCUIT	TEST CONDITION	MIN.	TYP.	MAX.	UNIT
Power Supply Current	$I_{CC}$	—	Pin 1, 3, 6-DC 2V input Pin 8-S.C.P. input Pin 2-6dB MODE Sub address (I) = 00H (II) = 02H (III) = 80H	46	56	70	mA
Terminal Voltage	$V_{11}$	—		5.0	6.0	7.0	V
	$V_{12}$			2.8	3.0	3.2	
	$V_{13}$			5.0	6.0	7.0	
	$V_{14}$			2.8	3.0	3.2	
	$V_{15}$			5.0	6.0	7.0	
	$V_{16}$			2.8	3.0	3.2	

AC characteristics (Unless otherwise specified,  $V_{CC} = 12V$ ,  $T_a = 25 \pm 3^\circ C$ )

Drive circuit

CHARACTERISTIC	SYMBOL	TEST CIR-CUIT	TEST CONDITION	MIN.	TYP.	MAX.	UNIT	
Frequency Characteristic	$f_c$	—	(Note 1)	10	20	30	MHz	
Cross-talk	$C_V$	—	(Note 2)	45	50	—	dB	
6dB Mode Gain	Max.	$G_{6MA}$	(Note 3)	SA (III) : FFH	9.0	10.0	11.5	dB
	Typ.	$G_{6TY}$		SA (III) : 80H	3.5	5.5	7.5	
	Min.	$G_{6MI}$		SA (III) : 00H	1.0	2.0	3.0	
0dB Mode Gain	Max.	$G_{0MA}$	(Note 4)	SA (III) : FFH	3.0	4.0	5.5	dB
	Typ.	$G_{0TY}$		SA (III) : 80H	1.5	-0.5	-2.5	
	Min.	$G_{0MI}$		SA (III) : 00H	-3.0	-4.0	-5.5	
Gain Control Range	Max.	$G_{VMA}$	(Max. Gain / Min. Gain) - (Typ. Gain) Both 0 / 6dB mode	3.0	5.0	6.0	dB	
	Min.	$G_{VMI}$		3.0	3.5	4.0		
Input Dynamic Range	Max. DC	$G_{IDA}$	(Note 5)	6.5	7.0	—	V	
	Min. DC	$G_{IDI}$		—	1.0	1.5		
Output Dynamic Range	Max. DC	$V_{ODA}$	(Note 6)	10.0	10.5	—	V	
	Min. DC	$V_{ODI}$		—	1.0	1.5		

Cut off circuit

CHARACTERISTIC	SYMBOL	TEST CIR-CUIT	TEST CONDITION	MIN.	TYP.	MAX.	UNIT	
Min. Control Range	$V_{LSB}$	—	(Note 7)	—	3.0	5.0	mV	
DC Voltage Control Range	Max.	$V_{CVI}$	(Note 8)	(I) (II) : FF03H	4.25	4.5	—	V
	Min.	$V_{CVA}$		(I) (II) : 0000H	—	1.6	1.8	
	Range	$V_{CV}$		(Max) - (Min)	2.5	2.9	—	
Center Off-set	$V_{COF}$	—	(Note 9)	(I) (II) : 0002H	0.8	1.0	1.2	V
Max. Input DC Level	$V_{IMA}$	—	(Note 10)	(I) (II) : 0000H	—	4.5	5.0	V
Min. Input DC Level	$V_{IMI}$			(I) (II) : FF03H	0.3	0.5	—	
Max. Output DC Level	$V_{OMA}$			(I) (II) : FF03H	—	5.4	6.0	
Min. Output DC Level	$V_{OMI}$			(I) (II) : 0000H	1.2	1.5	—	
Non Linear Point Value	SA : 7F00	$V_{AC1}$	(Note 11)	—	—	3.0	mV	
	SA : FF00	$V_{AC2}$		—	—	3.0		
	SA : FF01	$V_{AC3}$		—	—	3.0		

Threshold circuit

CHARACTERISTIC	SYMBOL	TEST CIR-CUIT	TEST CONDITION	MIN.	TYP.	MAX.	UNIT
S.C.P. Threshold	GATE P	$V_{GP}$	—	6.2	6.5	6.8	V
	Hori. P	$V_{HP}$		1.2	1.5	1.8	
	Vert. P	$V_{VP}$		1.2	1.5	1.8	
Blanking Level	$V_{BLNK}$	$V_{BL}$	(Note 12)	0.20	0.25	0.30	V

**TEST CONDITION**

Drive circuit

NOTE No.	ITEM	TERMINAL 2 MODE	SUB ADDRESS & DATA			MEASUREMENT METHOD	
			(I)	(II)	(III)		
1	Frequency Characteristic	6dB (7.5V)	00H	02H	FFH	(1) Pin 1 (Pin 3, 6) : DC 4V. (2) Adjust the input voltage at Pin 15 (Pin 13, 11) to make Output voltage = 5.5V. (3) Pin 1 (Pin 3, 6) : 1MHz, 300mV <sub>p-p</sub> , DC 4V, sine wave. Measure the output level (vout). (4) Measure the input level to make Output level = (vout - 3dB)	
2	Cross-talk	0dB (GND)	↑	↑	80H	(1) The same as Note 1. (2) The same as Note 1. (3) Pin 1 (Pin 3, 6) : 5MHz, DC 4V, sine wave. (4) Measure the cross-talk.	
3	6dB Mode Gain	Max.	6dB (7.5V)	↑	↑	FFH	(1) Pin 8 : S.C.P. or Gate pulse. (2) Pin 1 (Pin 6) : signal = (pedestal level = 2V, amplitude 3V). (3) Measure the output level. Calculate the 20log (output level / input level).
		Typ.				80H	
		Min.				00H	
4	0dB Mode Gain	Max.	0dB (GND)	↑	↑	FFH	(1) The same as Note 3. (2) Pin 1 (Pin 6) : signal = (pedestal level = 2V, amplitude 1.5V). (3) The same as Note 3.
		Typ.				80H	
		Min.				00H	
5	Input Dynamic Range	Max. DC	↑	↑	↑	00H	(1) The same as Note 3. (2) Pin 1 (Pin 6) : signal = (under Fig.) (3) Make input signal larger to output signal saturation level. Measure the input level. →G DA (4) Make input signal smaller to output signal saturation level. Measure the input level. →G DI
		Min. DC					

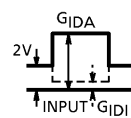



NOTE No.	ITEM		TERMINAL 2 MODE	SUB ADDRESS & DATA			MEASUREMENT METHOD
				(I)	(II)	(III)	
6	OUTPUT Dynamic Range	Max. DC	6dB (7.5V)	00H	02H	FFH	(1) Pin 8 : S.C.P. or Gate pulse. (2) Pin 1 (pin 6) : signal = (under Fig.) (3) Make input signal larger to output signal saturation level. Measure the output level. →G <sub>ODA</sub> (4) Make input signal smaller to output signal saturation level. Measure the output level. →G <sub>ODI</sub>
		Min. DC					

The diagram shows two waveforms. The first is labeled 'INPUT' and shows a square pulse with a peak-to-peak voltage of 2V. The second is labeled 'OUTPUT' and shows a square pulse with a peak-to-peak voltage of approximately 3V. The output pulse has two levels: a higher level labeled G<sub>ODA</sub> and a lower level labeled G<sub>ODI</sub>. Both waveforms are referenced to a common ground (GND).

Cut off circuit

NOTE No.	ITEM		TERMINAL 2 MODE	SUB ADDRESS & DATA			MEASUREMENT METHOD
				(I)	(II)	(III)	
7	Min. Variable Range		0dB (GND)	00H ↓ 01H	00H	80H	(1) The same as Note 6. (2) Pin 1 (Pin 3, 6) : DC 2V. (3) Subaddress data (I) : 00H→01H. Measure the DC voltage gap of output DC level.
8	Control Range	Max.	↑	FFH	03H	↑	(1) The same as Note 6. (2) The same as Note 7. (3) SA (I) (II) : FF03H, 0000H ; Measure the output DC level of each DATA.
		Min.		00H	00H		
9	Center Off-set		↑	00H	02H	↑	(1) The same as Note 6. (2) The same as Note 7. (3) (Output DC level) – (Input DC level 2V)
10	Max. Input DC Level		↑	00H	00H	↑	(1) The same as Note 6. (2) SA (I) (II) : 0000H ; Increase input DC level to output DC saturation level, Measure the input DC level. →V <sub>I</sub> MA (3) Decrease input DC level to output DC saturation level, Measure the output DC level. →V <sub>O</sub> MI (4) SA (I) (II) : FF03H ; Decrease input DC level to output DC saturation level, Measure the input DC level. →V <sub>I</sub> MI (5) Increase input DC level to output DC saturation level, Measure the output DC level. →V <sub>O</sub> MA
	Min. Input DC Level		↑	FFH	03H	↑	
	Max. Output DC Level		↑	00H	03H	↑	
	Min. Output DC Level		↑	FFH	03H	↑	
11	Non Liner Point Value	SA : 7F00	↑	7F00H ↓ 8000H	↑	↑	(1) The same as Note 6. (2) Pin 1 (Pin 3, 6) : DC 2V. (3) SA (I) (II) : 7F00H→8000H, FF00H→0001H, FF01H→0002H ; Measure the DC voltage gap of each point.
		SA : FF00		7F00H ↓ 8000H			
		SA : FF01		7F00H ↓ 8000H			
12	Blanking Level		0dB (GND)	00H	02H	↑	(1) Pin 8 : S.C.P. or Gate pulse. (2) Pin 1 (Pin 3, 6) : DC 2V. (3) Measure The BLANKING LEVEL.

TEST CIRCUIT

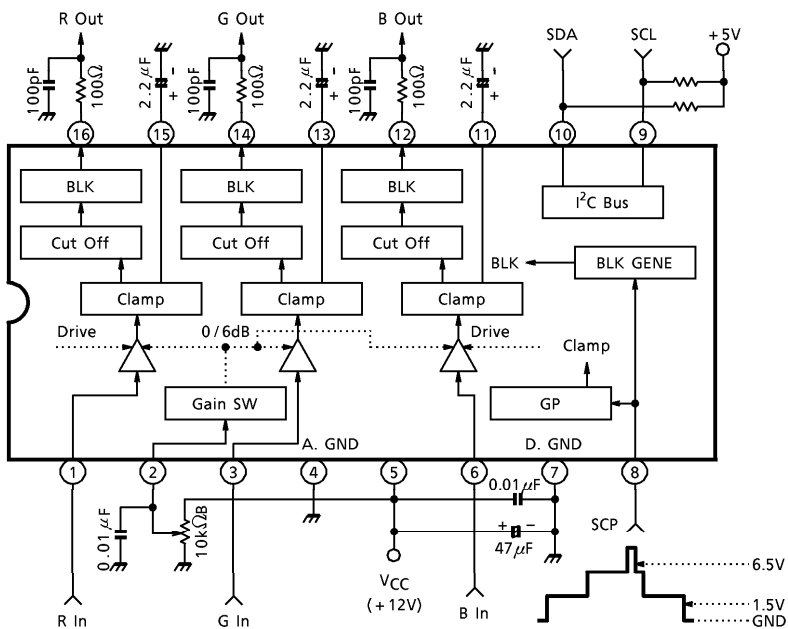

APPLICATION CIRCUIT

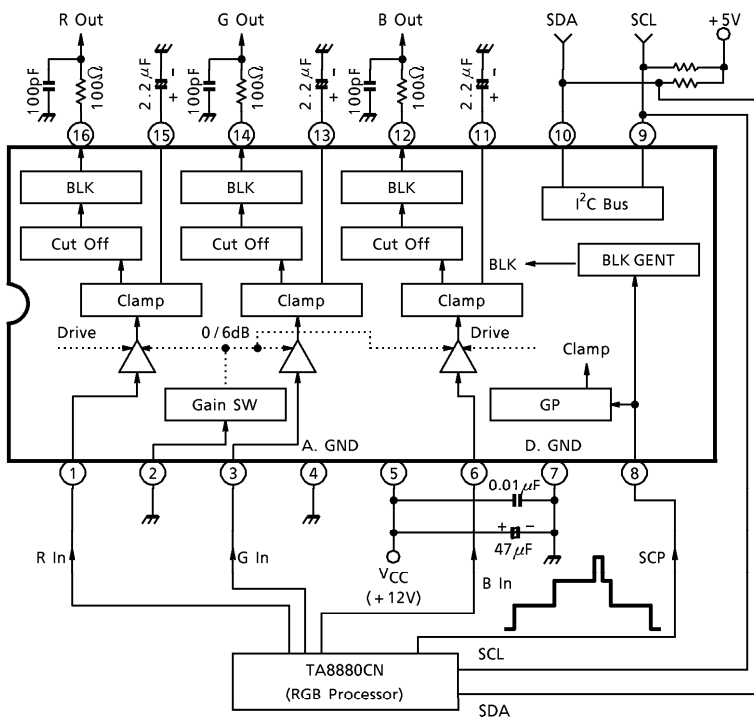

OUTLINE DRAWING  
DIP16-P-300-2.54B

Unit : mm

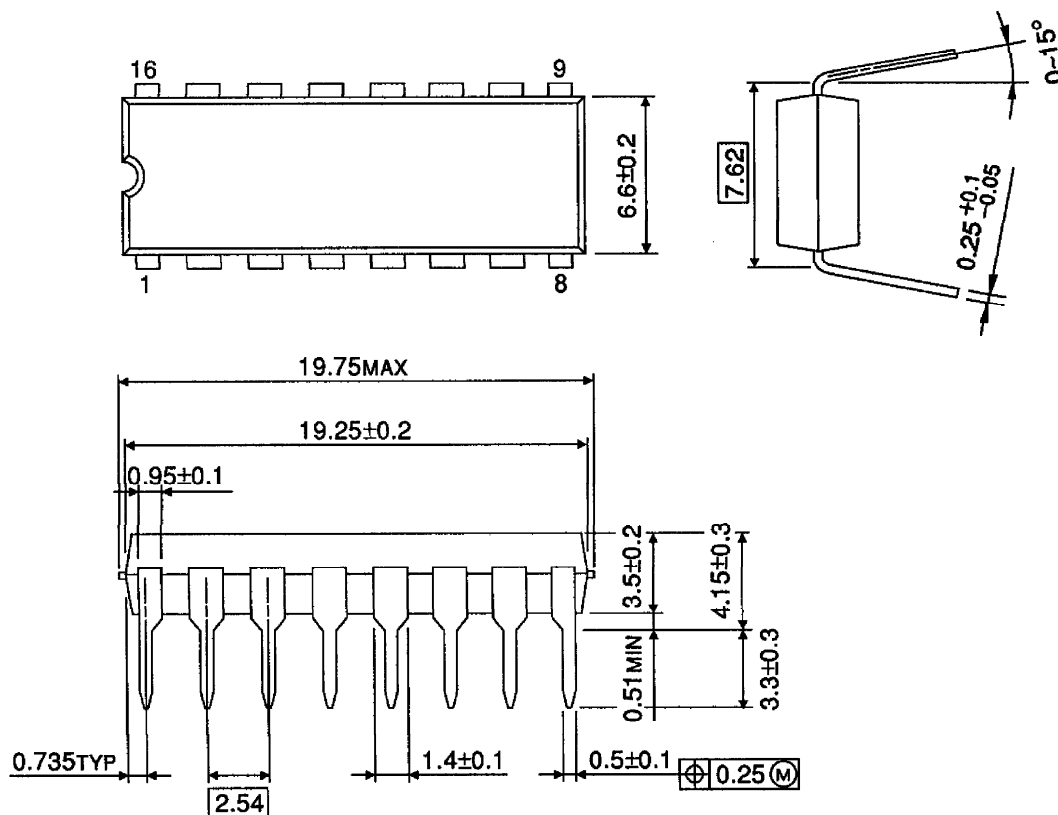

Weight : 1.11g (Typ.)