

TOSHIBA BIPOLAR LINEAR INTEGRATED CIRCUIT SILICON MONOLITHIC

TA8867AN

VIDEO, CHROMA, AND SYNC. SIGNAL PROCESSING IC FOR PAL / NTSC-SYSTEM COLOR TELEVISIONS.

The TA8867AN is Video, Chroma, and Sync. Signal processing IC for PAL / NTSC-system color televisions integrated in a 48pin shrink DIP package.

The TA8867AN can correct gain and phase error in 1H glass delay line of PAL-system color demodulator automatically.

FEATURES

Video

- Black stretching circuit
- Sharpness control circuit with internal delay lines
- DC restoration control
- Video noise reduction circuit

Chroma

- Automatic adjustment circuit for 1H glass delay line of PAL-system color demodulator
- Color differential signal output (R-Y, B-Y)
- RGB primary color signal output
- Linear RGB input

Sync. processing

- Sync. separation circuit with automatic separation level control
- Dual loop AFC
- Adjustment-free horizontal and vertical oscillation based on count-down system
- Automatic vertical frequency identification (50 / 60Hz)
- Forced Switch (50 / 60Hz)
- X-ray protection circuit

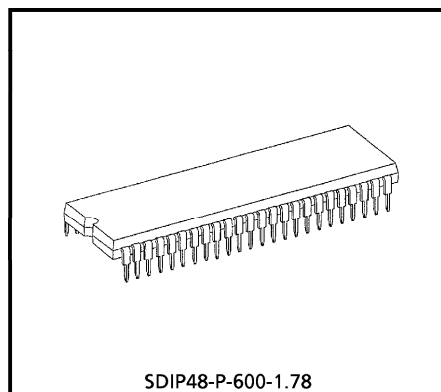

Weight : 4.81g (Typ.)

961001EBA2

- TOSHIBA is continually working to improve the quality and the reliability of its products. Nevertheless, semiconductor devices in general can malfunction or fail due to their inherent electrical sensitivity and vulnerability to physical stress. It is the responsibility of the buyer, when utilizing TOSHIBA products, to observe standards of safety, and to avoid situations in which a malfunction or failure of a TOSHIBA product could cause loss of human life, bodily injury or damage to property. In developing your designs, please ensure that TOSHIBA products are used within specified operating ranges as set forth in the most recent products specifications. Also, please keep in mind the precautions and conditions set forth in the TOSHIBA Semiconductor Reliability Handbook.
- The products described in this document are subject to foreign exchange and foreign trade control laws.
- The information contained herein is presented only as a guide for the applications of our products. No responsibility is assumed by TOSHIBA CORPORATION for any infringements of intellectual property or other rights of the third parties which may result from its use. No license is granted by implication or otherwise under any intellectual property or other rights of TOSHIBA CORPORATION or others.
- The information contained herein is subject to change without notice.

BLOCK DIAGRAM

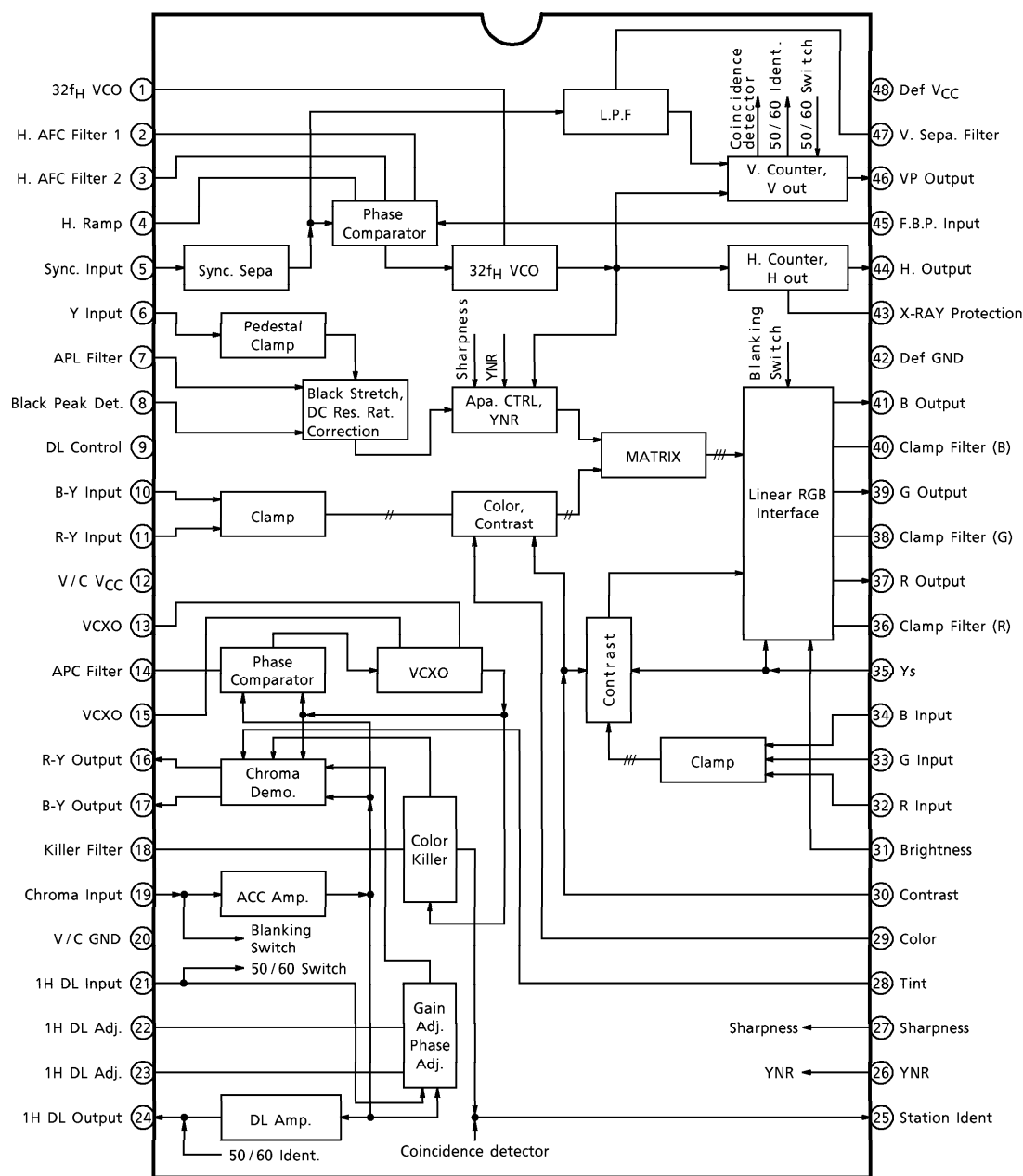

TERMINAL FUNCTION

PIN No.	PIN NAME	FUNCTION	INTERFACE CIRCUIT
1	32f _H VCO	This terminal is for adjustment free 32f _H voltage controlled oscillator. A ceramic resonator is connected. Recommended ceramic resonator is CSB503F30 (Murata Electronics).	
2	H. AFC Filter 1	A lag-lead type filter is connected to this terminal. Horizontal oscillator frequency is controlled by this terminal voltage.	
3	H. AFC Filter 2	A capacitor is connected to this terminal. Horizontal pulse phase is controlled by this terminal voltage.	
4	H. Ramp	This terminal is for H. Ramp wave generator. H. Ramp wave is reference for sync. signal processing circuit.	
5	Sync. Input	This terminal is for input terminal of sync. signal. Typical sync. signal amplitude is 2V _{p-p} (from sync. top to 100IRE). It is necessary for a signal source to drive with low impedance. When a resistor (≥ 500kΩ) connect between this terminal and GND, sync. separation level is higher than at normal condition.	

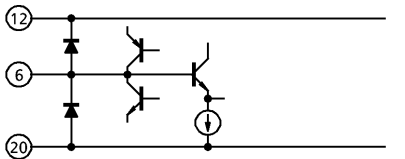
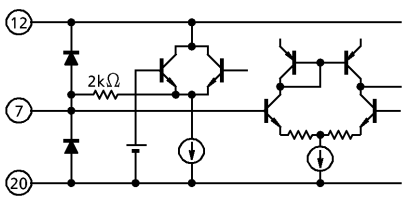
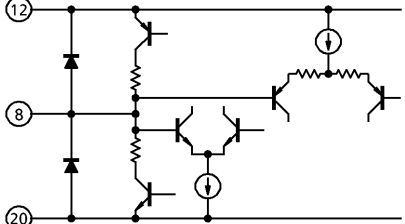
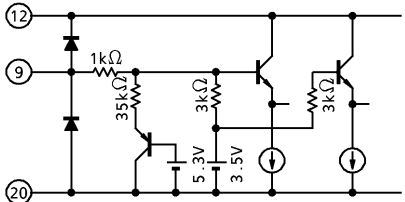
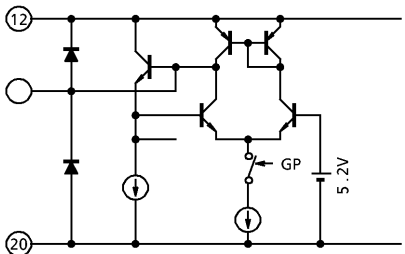
PIN No.	PIN NAME	FUNCTION	INTERFACE CIRCUIT
6	Y Input	This is Y Input terminal. Typical Y signal amplitude is 1V _{p-p} (from sync. top to 100IRE). It is necessary for a signal source to drive with low impedance.	
7	APL Filter	This terminal is for APL Filter for DC restoring circuit. Theoretically, the DC restoring level (T _{DC}) is shown as follows, $T_{DC} = \frac{2k\Omega}{2k\Omega + R} \times 50 + 100 \text{ [%]}$ External capacitor is about 10μF. In order to set DC restoring level to be 100%, this terminal is kept open.	
8	Black Peak Det.	This terminal is for black peak detection filter for black stretching circuit. In order to cancel black stretching function, this terminal is fixed on 3~5V.	
9	DL Control	Delay line in sharpness circuit is controlled by this terminal. If voltage 0~5V is applied to this terminal, delay time of the delay line will be change 125ns~210ns (Typ.). If this terminal is open, delay time of the delay line is 150ns (Typ.).	
10 11	B-Y Input R-Y Input	Color differential signal input terminal. The signal goes into color-matrix circuit after clamping.	

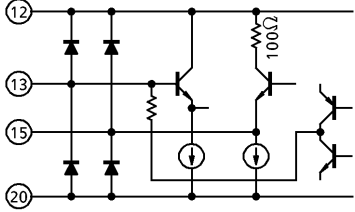
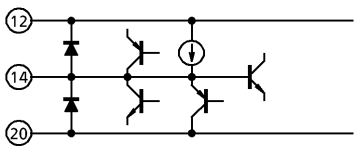
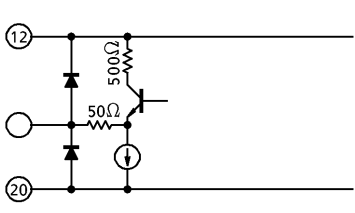
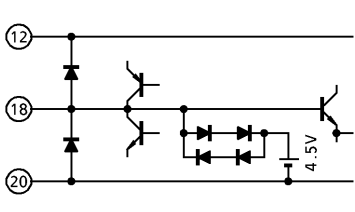
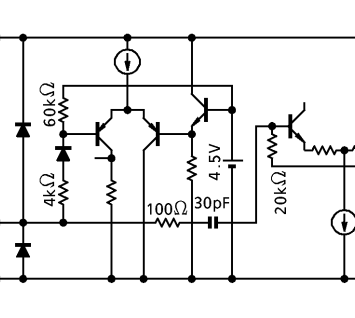
PIN No.	PIN NAME	FUNCTION	INTERFACE CIRCUIT
12	V/C V _{CC}	V _{CC} for Video and Chroma stage. Recommend applied voltage is 9V.	—
13 15	VCXO	These terminals are for a Xtal oscillator for chroma demodulator. It is necessary for P.C.B pattern to be near between the terminal and Xtal.	
14	APC Filter	This terminal is for APC filter. It is necessary for relative error between resistors in APC Filter to be less than ± 1%.	
16 17	R-Y Output B-Y Output	These terminals are for color differential signal output.	
18	Killer Filter	This terminal is for color killer filter. When killer active, this terminal voltage is 4.5V. When PAL is identified, this terminal voltage goes to 3.8V or 5.2V. When NTSC is identified, this terminal voltage goes to 3.8V.	
19	Chroma Input	This terminal is for chroma signal input. When AKB IC is used with TA8867AN, a resistor (about 56kΩ) connected between this terminal and GND, so horizontal and vertical blanking do not appear.	

PIN No.	PIN NAME	FUNCTION	INTERFACE CIRCUIT
20	V / C GND	GND for Video and Chroma circuits.	—
21	1H DL Input	This is input terminal of chroma signal through 1H glass delay line. Another function of this terminal is vertical frequency force switch. When applied voltage to the terminal is more than 5.8V, vertical pull-in range is 261.5H~353H (50Hz Mode). When applied voltage is lower than 3.8V, vertical pull-in range is 232H~297H (60Hz Mode). When open or applied voltage is 4.5V, vertical pull-in range is 232H~353H (Automatic Mode).	
22 23	1H DL Adj.	These terminals are for a capacitor for 1H glass delay line automatic adjustment circuit. The phase is controlled by voltage of pin 22. The gain is controlled by voltage of pin 23.	
24	1H DL Output	This terminal is for chroma signal output for 1H glass delay line. Another function of this terminal is vertical frequency identification output. When vertical frequency is 50Hz, DC level of this terminal is 5.3V. When vertical frequency is 60Hz, DC level is 3.3V.	
25	Station Ident	This terminal is for station identification and color identification output. When vertical sync. isn't detected, TA8867AN identifies as no signal input, and this terminal will be 0V. When vertical sync. is detected and color signal isn't detected, this terminal will be 2.5V. When vertical sync. and color signal is detected, this terminal will be 5V.	

PIN No.	PIN NAME	FUNCTION	INTERFACE CIRCUIT
26	YNR	<p>This terminal is for Y noise reduction level control. Control voltage range is 0~5V. When applied voltage to this terminal is increase, Y noise reduction level will be high. This terminal is pulled down to 0V when B.G.P is high. So, connect a limiting current resister between this terminal and output terminal of a controller if it will be necessary.</p>	
27	Sharpness	<p>This terminal is for sharpness control. Control voltage range is 0~5V. When applied voltage to this terminal is increase, sharpness level will be high. When this terminal is pulled up to VCC, RGB output is fixed to 3.3V. This function is for AKB IC.</p>	
28	Tint	<p>This terminal is for Tint control. Control voltage range is 0~5V. When applied voltage to this terminal increases, color demodulation phase will increase. When applied voltage is less than 1.0V, TA8867AN will be PAL Mode, and Tint control circuit will not operate.</p>	
29	Color	<p>This terminal is for Color control. Control voltage range is 0~5V. When applied voltage to this terminal increases, color level will be high.</p>	

PIN No.	PIN NAME	FUNCTION	INTERFACE CIRCUIT
30	Contrast	This terminal is for contrast control. Control voltage range is 0~5V. When applied voltage to this terminal increases, contrast level will be high.	
31	Brightness	This terminal is for brightness control. Control voltage range is 0~5V. When applied voltage to this terminal increases, brightness level will be high.	
32 33 34	R Input G Input B Input	These terminals are for Linear RGB input. Typical input signal level is 0.72V (0~100IRE) when terminated by 75Ω. It is necessary for a signal source to drive with low impedance.	
35	Ys	This terminal is for Fast blanking switch. When applied voltage to this terminal is less than 0.5V, TV signal is outputted to RGB output. When applied voltage is more than 1.0V, linear RGB signal is outputted to RGB output. When applied voltage is more than 6.5V, contrast of linear RGB is limited to -6dB (vs on contrast maximum condition).	
36 38 40	Clamp Filter (R) Clamp Filter (G) Clamp Filter (B)	These terminals are for Clamp filter for RGB output.	

PIN No.	PIN NAME	FUNCTION	INTERFACE CIRCUIT
37 39 41	R Output G Output B Output	These terminals are for primary color output. Maximum source current is 4mA.	
42	Def GND	GND for sync. signal processing circuit.	—
43	X-RAY Protection	This terminal is for X-RAY protection input. When applied voltage to this terminal is more than 3.3V, horizontal output is fixed to 0V. And this condition is held until Def V _{CC} (pin 48) is less than 3.0V.	
44	H. Output	This terminal is for horizontal pulse output. Output pulse level is 0V (low), and 5.0V (high). Output pulse duty is 40% (Typ). Output type of this terminal is open emitter. So, it is necessary to connect a resistor between this terminal and GND.	
45	F.B.P. Input	This terminal is F.B.P. input. It is necessary for F.B.P. amplitude to limit to be less than H. V _{CC} voltage at this terminal by using resistors or a zener diode. Result of sync. separation circuit can be observed at waveform of this terminal.	
46	VP Output	This terminal is for vertical pulse output. Negative pulse is outputted this terminal. Output type of this terminal is open collector.	

PIN No.	PIN NAME	FUNCTION	INTERFACE CIRCUIT
47	V. Sepa. Filter	This terminal is for vertical sync. separation filter.	
48	Def V _{CC}	V _{CC} for sync. signal processing circuit. Recommend voltage is 9V.	—

MAXIMUM RATINGS (Ta = 25°C)

CHARACTERISTIC	SYMBOL	RATING	UNIT
Supply Voltage	V _{CC}	14	V
Power Dissipation	P _{D max}	1.7 (Note)	W
Applied Voltage	e _{in}	4.0	V _{p-p}
Operating Temperature	T _{opr}	- 20~65	°C
Storage Temperature	T _{stg}	- 55~150	°C

(Note) Derated above Ta = 25°C in the proportion of 13.5mW.

RECOMMENDED OPERATING CONDITION

PIN No.	PIN NAME	SYMBOL	MIN.	TYP.	MAX.	UNIT
12	V / C V _{CC}	V _{CC} #12	8.1	9.0	9.9	V
48	Def V _{CC}	V _{CC} #48	8.1	9.0	9.9	

ELECTRICAL CHARACTERISTICSDC voltage characteristics (Unless otherwise specified. $V_{CC} (\#12) = 9V$, $V_{CC} (\#48) = 9V$, $T_a = 25^\circ C$)

PIN No.	PIN NAME	SYMBOL	MIN.	TYP.	MAX.	UNIT	NOTE
1	32f _H VCO	V1	5.0	5.9	7.0	V	
2	H. AFC Filter 1	V2	6.5	7.5	8.5		
3	H. AFC Filter 2	V3	3.0	3.9	4.8		
5	Sync. In	V5	1.5	2.3	3.1		No signal input
6	Y Input	V6	3.0	3.8	4.5		Clamping Level
8	Black Peak Det.	V8	5.0	5.9	6.8		
9	DL Control	V9	2.5	3.5	4.5		
10	B-Y Input	V10	4.5	5.2	6.1		Clamping Level
11	R-Y Input	V11	4.5	5.2	6.1		Clamping Level
13	VCXO	V13	3.5	5.0	6.5		
15	VCXO	V15	5.5	6.5	7.5		
16	R-Y Output	V16	4.0	4.8	5.6		
17	B-Y Output	V17	4.0	4.8	5.6		
18	Killer Filter	V18	3.7	4.5	5.3		No signal input
19	Chroma Input	V19	3.0	3.8	4.6		
21	1H DL Input	V21	3.7	4.5	5.2		
24	1H DL Output	V24	4.5	5.2	6.0		No signal input
25	Station Ident	V25	—	—	0.2		No signal input
32	R Input	V32		4.3			AC GND, pin 30 : 2.5V
33	G Input	V33		4.3			AC GND, pin 30 : 2.5V
34	B Input	V34		4.3			AC GND, pin 30 : 2.5V
37	R Output	V37		3.5			In trace period, pin 31 : 2.5V
39	G Output	V39		3.5			In trace period, pin 31 : 2.5V
41	B Output	V41		3.5			In trace period, pin 31 : 2.5V

DC CURRENT CHARACTERISTICS(Unless otherwise specified. $V_{CC} (\#12) = 9V$, $V_{CC} (\#48) = 9V$, $T_a = 25^\circ C$)

PIN No.	PIN NAME	SYMBOL	MIN.	TYP.	MAX.	UNIT
12	V/C V_{CC}	$I_{CC} \#12$	45	75	100	mA
48	Def V_{CC}	$I_{CC} \#48$	12	23	35	

AC CHARACTERISTICS (Unless otherwise specified. $V_{CC} (\#12) = 9V$, $V_{CC} (\#48) = 9V$, $T_a = 25^\circ C$)

CHARACTERISTIC	SYMBOL	TEST CIR-CUIT	TEST CONDITION	MIN.	TYP.	MAX.	UNIT
----------------	--------	---------------	----------------	------	------	------	------

Video

Input Clamping Level		V_{CLMP}	—	(Note 1)	3.0	3.8	4.5	V
Brightness Control Characteristic	(Min.)	V_{BRGHT}	—	(Note 2)		1.5		V
	(Center)					3.5		
	(Max.)					4.5		
Dynamic Range of Video Input		Dr_6	—	(Note 3)	0.8	1.5	1.8	V_{p-p}
Max. Output Voltage of RGB Out.		V_{OMAX}	—	(Note 4)		6.5		V
Horizontal Blanking Level		V_{HBLK}	—	(Note 5)		1.2		V
Vertical Blanking Level		V_{VBLK}	—	(Note 6)		1.2		V
Vertical Blanking Period	(50Hz)	T_{VBLK}	—	(Note 7)		22		H
	(60Hz)					16		
Contrast Control Characteristic	(Min.)	G_{CONT}	—	(Note 8)		-6.0		dB
	(Center)					6.0		
	(Max.)					14.0		
Frequency Characteristics		G_f	—	(Note 9)		± 2.0		dB
Sharpness Control Characteristic Y IN→RGB OUT	(Min.)	G_{SHRP}	—	(Note 10)	-3.0	2.0	5.0	dB
	(Max.)				26	32	38	
Delay Time Control Characteristics of Aperture Circuit	(Min.)	t_{AC}	—	(Note 11)	75	125	—	ns
	(Max.)				—	210	280	
Gain of DC Restore Amp.		G_{DCA}	—	(Note 12)		0.5		
Black Stretch Amp. Maximum Gain		G_{EXP}	—	(Note 13)		1.5		
Noise Reduction Level		G_{NR}	—	(Note 14)		-5.0		dB

Chroma

ACC Characteristics	(Min.)	e_{ACC}	—	(Note 15)	—	—	10	mV_{p-p}
	(Max.)				400	—	—	
Killer Operation Level		e_K	—	(Note 16)	—	1.0	3.0	mV_{p-p}
APC Control Sensitivity	(4.43MHz)	β_{APC}	—	(Note 17)	1.3	1.8	—	kHz/V
	(3.58MHz)				0.9	1.3	—	
APC Control Range	(4.43MHz)	f_{cAPC}	—	(Note 18)	± 600	± 800	—	Hz
	(3.58MHz)				± 400	± 600	—	
Color Differential Signal Output Level (PAL)	(R-Y)	e_{CHRM}	—	(Note 19)		0.39		V_{p-p}
	(B-Y)					0.70		
Color Differential Signal Output Level (NTSC)	(R-Y)	e_{CHRM}	—	(Note 20)		0.50		V_{p-p}
	(B-Y)					0.60		

CHARACTERISTIC	SYMBOL	TEST CIR-CUIT	TEST CONDITION	MIN.	TYP.	MAX.	UNIT	
Relative Amplitude (R-Y)	(PAL)	e_R / e_B	—	(Note 21)	0.42	0.56	0.70	
	(NTSC)				0.63	0.84	1.05	
Relative Phase (R-Y)	(PAL)	θ_{RB}	—	(Note 22)	82	90	98	°
	(NTSC)				105	112	125	
Relative Amplitude (G-Y)	(PAL)	e_G / e_B	—	(Note 23)	0.29	0.38	0.47	
	(NTSC)				0.25	0.33	0.41	
Relative Phase (G-Y)	(PAL)	θ_{GB}	—	(Note 24)	211	235	259	°
	(NTSC)				213	237	261	
1H DL Gain Adjustment range	(Min.)	DLAMP	—	(Note 25)	-12	-8	-4	dB
	(Max.)				4	8	12	
1H DL Phase Adjustment Range	(Min.)	DLPHS	—	(Note 26)	-5	-20	-40	°
	(Max.)				5	20	40	
Color Control Characteristics pin 10 or pin 11→ pin 40 or pin 36	(Min.)	GCOLOR	—	(Note 27)	—	-35	-15	dB
	(Max.)				17	20	23	
Tint Control Characteristics	(Min.)	θ_{TINT}	—	(Note 28)	-30	-45	-50	
	(Max.)				30	45	50	
PAL/NTSC Select Threshold Voltage.	$V_{P/N}$	—	(Note 29)	0.5	0.8	1.2	V	

Sync. processing

Sync. Sepa. Current Sensitivity	I_{IN5}	—	(Note 30)	10	20	30	μA
H. AFC Phase Detection Current	I_{HDet}	—	(Note 31)	480	600	720	μA
Phase Detector Inactive Period	(50Hz)	T_S	—	(Note 32)	307~6		H
	(60Hz)				257~6		
2nd AFC Active Period	AFC _{ON}	—	(Note 33)	—	0.5	0.8	μs
2nd AFC Control Range	AFC _{Wid}	—	(Note 34)	12.8	15.8	—	μs
Supply Voltage for 32f _H VCO in Active	V_{VCO}	—	(Note 35)	2.8	3.8	4.8	V

CHARACTERISTIC	SYMBOL	TEST CIR-CUIT	TEST CONDITION	MIN.	TYP.	MAX.	UNIT	
Supply Voltage for Horizontal Output in Active	V _{HON}	—	(Note 36)	3.7	4.2	4.7	V	
Horizontal OSC Free-Run Frequency	f _{HO}	—	(Note 37)	15.000	15.650	16.300	kHz	
Horizontal OSC Pull-In Range	PR _{AFC}	—	(Note 38)	± 500	—	—	Hz	
Horizontal OSC Hold Range	LR _{AFC}	—	(Note 39)	± 500	—	—	Hz	
AFC control Sensitivity	β _{AFC}	—	(Note 40)	2.2	2.7	3.4	Hz / mV	
Horizontal Pulse Duty	T _{DUT}	—	(Note 41)	36	40	44	%	
Horizontal Pulse Level	(Low)	V _{HL}	—	(Note 42)	—	0.0	0.2	V
	(High)	V _{HH}			4.7	5.0	5.3	
X-RAY Protection Threshold Voltage	V _{XON}	—	(Note 43)	3.0	3.3	3.6	V	
X-RAY Protection Hold Voltage	V _{XHLD}	—	(Note 44)	—	—	3.0	V	
Vertical Pulse Width	T _{VP}	—	(Note 45)	—	10	—	H	
Vertical OSC Pull-In Range	(50Hz)	PL _V	—	(Note 46)	261.5~353		H	
	(60Hz)				232~297			
Vertical OSC Free-Run Frequency	(50Hz)	f _{VO}	—	(Note 47)	—	353	—	H
	(60Hz)				—	297	—	
Vertical OSC Pull-In Range Select Voltage	(50Hz)	V _{SW50}	—	(Note 48)	5.2	5.7	6.2	V
	(60Hz)	V _{SW60}			2.6	3.1	3.6	
Vertical frequency identification voltage	(50Hz)	V _{ID50}	—	(Note 49)	4.8	5.3	5.8	V
	(60Hz)	V _{ID60}			2.8	3.3	3.8	

Linear RGB processing

RGB Input Dynamic Range	Dr _{RGB}	—	(Note 50)	0.7	2.0	—	V _{p-p}	
Gain (RGB input→RGB Output)	G _{IO}	—	(Note 51)	10.0	13.5	17.0	dB	
Contrast Control Limiting Level	G _{LIMIT}	—	(Note 52)	- 3.0	- 5.5	- 9.0	dB	
Switching Threshold Voltage	(TV→RGB)	V _{TV / TXT}	—	(Note 53)	—	—	1.0	V
	(RGB→OSD)	V _{TX / OSD}			5.8	6.5	7.2	
Switching Time	(TV→RGB)	t _{TV / TXT}	—	(Note 54)	—	—	100	ns
	(TV→OSD)	t _{TXT / TV}			—	—	100	

TEST CONDITON

Video

NOTE	CHARACTERISTIC	SYMBOL	MEASUREMENT METHOD
1	Input Clamping Level	V_{CLMP}	(1) Connect a capacitor (0.01 μ F) between the luminance input terminal (pin 6) and ground (2) Measure the terminal voltage of the luminance input terminal (pin 6). (V_{CLMP} [V])
2	Brightness Control Characteristic	V_{BRGHT}	(1) Connect a capacitor (0.01 μ F) between the luminance input terminal (pin 6) and ground, and connect a capacitor (0.01 μ F) between the chroma input terminal (pin 19) and ground. (2) Set the voltage of the brightness adjustment terminal (pin 31) to 0V, 2.5V, and 5.0V. Then measure the voltage of the B output terminal (pin 41) during the trace period at each voltage level. (V_{BRGHT} [V])
3	Dynamic Range of Video Input	Dr_6	(1) Set the contrast adjustment terminal (pin 30) to 0V, and set the brightness adjustment terminal (pin 31) to 1.5V. (2) Connect a DC power supply to the luminance input terminal (pin 6) and apply the same voltage as V_{CLMP} . (3) While measuring the output voltage of the B output terminal (pin 41), increase the voltage of the DC power supply connected to the luminance input terminal (pin 6). (4) Measure the voltage of the DC power supply connected to the luminance input terminal (pin 6) when the output voltage of the B output terminal (pin 41) saturates. (V [V]) (5) $Dr_6 [V_{p-p}] = V - V_{CLMP}$
4	Maximum Output Voltage of RGB Output	V_{OMAX}	(1) Set the contrast adjustment terminal (pin 30) to 5.0V, and set the brightness adjustment terminal (pin 31) to 5.0V. (2) Connect a DC power supply to the luminance input terminal (pin 6) and apply the same voltage as V_{CLMP} . (3) While measuring the output voltage of the B output terminal (pin 41), raise the voltage of the DC power supply connected to the luminance input terminal (pin 6). (4) Measure the voltage of the DC power supply connected to the luminance input terminal (pin 6) when the output voltage of the B output terminal (pin 41) saturates. (V_{OMAX} [V])
5	Horizontal Blanking Level	V_{HBLK}	(1) Connect a capacitor (0.01 μ F) between the luminance input terminal (pin 6) and ground, and connect a capacitor (0.01 μ F) between the chroma input terminal (pin 19) and ground. (2) Measure the voltage of the B output terminal (pin 41) during the Horizontal blanking period. (V_{HBLK} [V])

NOTE	CHARACTERISTIC	SYMBOL	MEASUREMENT METHOD
6	Vertical Blanking Level	V _{VBLK}	<p>(1) Connect a capacitor (0.01μF) between the luminance input terminal (pin 6) and ground, and connect a capacitor (0.01μF) between the chroma input terminal (pin 19) and ground.</p> <p>(2) Measure the voltage of the B output terminal (pin 41) during the vertical blanking period. (V_{VBLK} [V])</p>
7	Vertical Blanking Period	T _{VBLK}	<p>(1) Connect a capacitor (0.01μF) between the luminance input terminal (pin 6) and ground, and connect a capacitor (0.01μF) between the chroma input terminal (pin 19) and ground.</p> <p>(2) Measure the vertical blanking period of the B output terminal (pin 41)</p>
8	Contrast Control Characteristic	G _{CONT}	<p>(1) Connect a capacitor (0.01μF) between the chroma input terminal (pin 19) and ground.</p> <p>(2) Set the sharpness adjustment terminal (pin 27) to 0V, and set the brightness adjustment terminal (pin 31) to 1.5V.</p> <p>(3) Input a multi-burst signal to the luminance input terminal (pin 6).</p> <p>(4) Set the contrast adjustment terminal (pin 30) to 0V, 2.5V, and 5V. Then measure the AC gain between the luminance input terminal (pin 6) and B output terminal (pin 41) at each voltage level. (G_{CONT} [dB])</p>
9	Frequency Characteristic	G _f	<p>(1) Connect a capacitor (0.01μF) between the chroma input terminal (pin 19) and ground.</p> <p>(2) Input a multi-burst signal to the luminance input terminal (pin 6).</p> <p>(3) Set the picture quality adjustment terminal (pin 27) to 5.0V, the contrast adjustment terminal (pin 30) to 2.5V, the brightness adjustment terminal (pin 31) to 1.5V, and the aperture control terminal (pin 9) to 6.5V.</p> <p>(4) Observe the output waveform of the B output terminal (pin 41), and then measure the AC gain at 10MHz against 100kHz. (G_f [dB])</p>

NOTE	CHARACTERISTIC	SYMBOL	MEASUREMENT METHOD
10	Sharpness Control Characteristic	G _{SHRP}	<p>(1) Set the color adjustment terminal (pin 29) to 0V, the contrast adjustment terminal (pin 30) to 2.5V, and the brightness adjustment terminal (pin 31) to 1.5V.</p> <p>(2) Set the Sharpness adjustment terminal (pin 27) to 5.0V.</p> <p>(3) Input a multi-burst signal to the luminance input terminal (pin 6).</p> <p>(4) Measure the signal amplitude of the B output terminal (pin 41) at a frequency of 100kHz (V_{100k} [V_{p-p}]) and at a frequency of 4MHz (V_{4M} [V_{p-p}]).</p> <p>(5) G_{SHRP} (Max.) [dB] = $20 \log \frac{V_{4M}}{V_{100k}}$</p> <p>(6) Set the sharpness adjustment terminal (pin 27) to 0V, and measure same.</p> <p>(7) G_{SHRP} (Min.) [dB] = $20 \log \frac{V_{4M}}{V_{100k}}$</p>
11	Delay Time Control Characteristics of Aperture Circuit	t_{AC}	<p>(1) Set the picture quality adjustment terminal (pin 27) to 5.0V, the color adjustment terminal (pin 29) to 0V, the contrast adjustment terminal (pin 30) to 2.5V, and the brightness adjustment terminal (pin 31) to 1.5V.</p> <p>(2) Set the aperture control terminal (pin 9) to 0V.</p> <p>(3) Input a multi-burst signal into the luminance input terminal (pin 6).</p> <p>(4) Measure the frequency (f_m [MHz]) at which the minimum AC gain is gotten between the luminance input terminal (pin 6) and the B output terminal (pin 41).</p> <p>(5) t_{AC} (Max.) [μs] = $\frac{1}{f_m}$</p> <p>(6) Set the aperture control terminal (pin 9) to 5.0V, and measure the frequency (f_m [MHz]) at which the minimum AC gain is gotten.</p> <p>(7) t_{AC} (Min.) [μs] = $\frac{1}{f_m}$</p>

NOTE	CHARACTERISTIC	SYMBOL	MEASUREMENT METHOD
12	Gain of DC Restore Amplitude	G _{DCA}	<p>(1) Set the contrast adjustment terminal (pin 30) to 2.5V and the brightness adjustment terminal (pin 31) to 1.5V.</p> <p>(2) Measure the AC gain between the luminance input terminal (pin 6) and the B output terminal (pin 41). (G [times])</p> <p>(3) Connect a capacitor (0.01μF) between the luminance input terminal (pin 6) and ground.</p> <p>(4) Connect an ammeter and DC power supply in series between the APL filter terminal (pin 7) and the GND.</p> <p>(5) Adjust the voltage of the DC power supply until the ammeter reads is 0mA.</p> <p>(6) Measure the voltage of the B output terminal (pin 41) during the trace period. (V₀ [V])</p> <p>(7) Decrease the voltage of the DC power supply by 0.1V.</p> <p>(8) Measure the voltage of the B output terminal (pin 41) during the trace period. (V₁ [V])</p> <p>(9) $G_{DCA} = \frac{V_0 - V_1}{0.1 [V]} \times \frac{1}{G}$</p>
13	Black Stretch Amplitude Maximum Gain	G _{EXP}	<p>(1) Set the contrast adjustment terminal (pin 30) to 2.5V and set the brightness adjustment terminal (pin 31) to 1.5V.</p> <p>(2) Input a signal with a frequency of 500kHz and an amplitude of 100mV_{p-p} into the luminance input terminal (pin 6).</p> <p>(3) Measure the output amplitude of the B output terminal (pin 41) during the trace period when the black peak detection terminal (pin 8) is set to 5.5V. (V₀ [V_{p-p}])</p> <p>(4) Measure the output amplitude of the B output terminal (pin 41) during the trace period when the black peak detection terminal (pin 8) is set to 6.5V. (V₁ [V_{p-p}])</p> <p>(5) $G_{EXP} = \frac{V_1}{V_0}$</p>
14	Noise Reduction Level	G _{NR}	<p>(1) Set the sharpness adjustment terminal (pin 27) to 0V, the color adjustment terminal (pin 29) to 0V, the contrast adjustment terminal (pin 30) to 2.5V and the brightness adjustment terminal (pin 31) to 1.5V.</p> <p>(2) Set the YNR terminal (pin 26) to 0V.</p> <p>(3) Input a signal with a frequency of 100kHz and an amplitude of 30mV_{p-p} into the luminance input terminal (pin 6).</p> <p>(4) Measure the output amplitude of the B output terminal (pin 41). (V₀ [V])</p> <p>(5) Set the YNR terminal (pin 26) to 5.0V.</p> <p>(6) Measure the output amplitude of the B output terminal (pin 41). (V₁ [V])</p> <p>(7) $G_{NR} [dB] = 20 \log \frac{V_1}{V_0}$</p>

Chroma

NOTE	CHARACTERISTIC	SYMBOL	MEASUREMENT METHOD
15	ACC Characteristics	e_{ACC}	<p>(1) Input a black burst signal (burst level of 100mV_{p-p}) into the chroma input terminal (pin 19).</p> <p>(2) Measure the output amplitude of the B-Y output terminal (pin 17).</p> <p>(3) Reduce the burst level, then measure it when the output amplitude of the B-Y output terminal (pin 17) becomes -3dB less the original amplitude. (e_{ACC} (Min.) [dB])</p> <p>(4) Increase the burst level, then measure it when the output amplitude of the B-Y output terminal (pin 17) becomes -3dB plus the original amplitude. (e_{ACC} (Max.) [dB])</p>
16	killer Operation Level	e_K	<p>(1) Input a black burst signal (burst level of 100mV_{p-p}) into the chroma input terminal (pin 19).</p> <p>(2) Measure the voltage of the station ID terminal (pin 25).</p> <p>(3) Reduce the burst level, then measure it when the voltage of the station ID terminal (pin 25) becomes 2.5V. (e_K [mV_{p-p}])</p>
17	APC Control Sensitivity	β_{APC}	<p>(1) Connect a capacitor (0.01μF) between the chroma input terminal (pin 19) and ground.</p> <p>(2) Connect a 1kΩ resistor between the killer filter terminal (pin 18) and the GND.</p> <p>(3) Connect a high-input-resistance buffer amp to the VCXO terminal (pin 15), and a frequency counter to the buffer amp output.</p> <p>(4) Connect a DC power supply to the APC filter terminal (pin 14). After applying 4.475V and 4.525V, read the frequency each condition. (Let each reading be f_L [MHz] and f_H [MHz].)</p> <p>(5) β_{APC} [kHz/V] = $\frac{f_H - f_L}{50 \text{ [mv]}}$</p>
18	APC Control Range	f_{cAPC}	<p>(1) Connect a DC power supply to the APC filter terminal (pin 14).</p> <p>(2) Set the voltage of the DC power supply to 4.5V, then measure the VCXO oscillation frequency using a small-capacity probe, such as an FET probe, attached to the VCXO terminal (pin 15). (f_o [Hz])</p> <p>(3) Set the voltage of the DC power supply to 4.0V and 5.0V, then measure VCXO oscillation frequency in the same way. (f_L [Hz], f_H [Hz])</p> <p>(4) f_{cAPC} [Hz] = $f_L - f_o$ or f_{cAPC} [Hz] = $f_H - f_o$</p>

NOTE	CHARACTERISTIC	SYMBOL	MEASUREMENT METHOD
19	Color Differential Signal Output Level (PAL)	e_{CHRM}	(1) Input a rainbow color-bar signal (burst level of $100\text{mV}_{\text{p-p}}$, burst chroma ratio of 1 : 1) into the chroma input terminal (pin 19). (2) Measure the output signal amplitudes of the R-Y output terminal (pin 16) and the B-Y output terminal (pin 17). ($e_{\text{CHRM}} [V_{\text{p-p}}]$)
20	Color Differential Signal Output Level (NTSC)	e_{CHRM}	(1) Input a rainbow color-bar signal (burst level of $100\text{mV}_{\text{p-p}}$, burst chroma ratio of 1 : 1) into the chroma input terminal (pin 19). (2) Apply 2.5V to the tint adjustment terminal (pin 28). (3) Measure the output signal amplitudes of the R-Y output terminal (pin 16) and the B-Y output terminal (pin 17). ($e_{\text{CHRM}} [V_{\text{p-p}}]$)
21	Relative Amplitude (R-Y)	$e_{\text{R}}/e_{\text{B}}$	(1) Input a rainbow color-bar signal (burst level of $100\text{mV}_{\text{p-p}}$, burst chroma ratio of 1 : 1) into the chroma input terminal (pin 19). (2) Measure the output signal amplitudes of the R output terminal (pin 37) and the B output terminal (pin 41) during the trace period. (Let these amplitudes be $V_{\text{R-Y}} [V_{\text{p-p}}]$ and $V_{\text{B-Y}} [V_{\text{p-p}}]$, respectively.) (3) $e_{\text{R}}/e_{\text{B}} = \frac{V_{\text{R-Y}}}{V_{\text{B-Y}}}$ (4) To take measurements with the NTSC system, apply 2.5V to the tint adjustment terminal (pin 28).
22	Relative Phase (R-Y)	θ_{RB}	(1) Input a rainbow color-bar signal (burst level of $100\text{mV}_{\text{p-p}}$, burst chroma ratio of 1 : 1) into the chroma input terminal (pin 19). (2) Measure the relative phases of the output waveforms of the R output terminal (pin 37) and the B output terminal (pin 41) with respect to their peak positions.
23	Relative Amplitude (G-Y)	$e_{\text{G}}/e_{\text{B}}$	Applying the same method used to measure the relative R-Y amplitude, obtain the amplitude ratio of the G output terminal (pin 39) and the B output terminal (pin 41) during the trace period.
24	Relative Phase (G-Y)	θ_{GB}	Applying the same method used to measure the relative G-Y phase, measure the relative phases from the output waveforms of the G output terminal (pin 39) and the B output terminal (pin 41).

NOTE	CHARACTERISTIC	SYMBOL	MEASUREMENT METHOD
25	1H DL Gain Adjustment Range	DLAMP	<p>(1) Input a black burst signal (burst level of $100\text{mV}_{\text{p-p}}$) into the chroma input terminal (pin 19) and the 1H delay line input terminal (pin 21).</p> <p>(2) Connect an attenuator and phase shift circuit between the 1H delay line input terminal (pin 21) and the signal source.</p> <p>(3) Adjust the phase shift of burst signal to 90° using the phase shift circuit.</p> <p>(4) While observing the voltage of the 1H delay line adjustment terminal (pin 23), reduce the signal amplitude applied to the 1H delay line input terminal (pin 21) using the attenuator.</p> <p>(5) Read the attenuator value when the voltage of the 1H delay line input terminal (pin 23) is 4.0V and let it be A [dB]. In the same way, read the attenuator value when the voltage is 5.0V and let it be B [dB].</p> <p>(6) $\text{DLAMP (Min.) [dB]} = A + 18$; $\text{DLAMP (Max.) [dB]} = B + 18$</p>
26	1H DL Phase Adjustment Range	DLPHS	<p>(1) Input a black burst signal (burst level of $100\text{mV}_{\text{p-p}}$) into the chroma input terminal (pin 19) and the 1H delay line input terminal (pin 21).</p> <p>(2) Connect an attenuator and a phase shifter between the 1H delay line input terminal (pin 21) and the signal source.</p> <p>(3) Adjust the phase shift of burst signal to 90° using the phase shift circuit. Then set the attenuator to -18dB.</p> <p>(4) While observing the voltage of the 1H delay line adjustment terminal (pin 22), change the signal phase applied to the 1H delay line input terminal (pin 21) by using the phase shifter.</p> <p>(5) Measure a phase shift when the voltage of the 1H delay line adjustment terminal (pin 22) is 4.0V and let it be DLPHS (Min). Using the same method, measure the phase shift when the voltage is 5.0V and let it be DLPHS (Max).</p>

NOTE	CHARACTERISTIC	SYMBOL	MEASUREMENT METHOD
27	Color Control Characteristics	G_{COLOR}	<p>(1) Set the sharpness adjustment terminal (pin 27) to 0V, the contrast adjustment terminal (pin 30) to 2.5V, and the brightness adjustment terminal (pin 31) to 1.5V.</p> <p>(2) Input a rainbow color-bar signal (burst level of 100mV_{p-p}, burst chroma ratio of 1 : 1) to the chroma input terminal (pin 19).</p> <p>(3) Set the voltage of the color adjustment terminal (pin 29) to 0V, 2.5V, and 5V. Then measure the output signal amplitude V_{B-Y} [V_{p-p}] of the B-Y output terminal (pin 17) and the signal amplitude V_B [V_{p-p}] of the B output terminal (pin 41) during the trace period at each voltage level.</p> <p>(4) $G_{\text{COLOR}} \text{ [dB]} = 20 \log \frac{V_B}{V_{B-Y}}$</p>
28	Tint Control Characteristics	θ_{TINT}	<p>(1) Input a rainbow color-bar signal (burst level of 100mV_{p-p}, burst chroma ratio of 1 : 1) to the chroma input terminal (pin 19).</p> <p>(2) Set the voltage of the tint adjustment terminal (pin 28) to 1.1V. Then observe the output waveform of the B output terminal (pin 41).</p> <p>(3) Change the burst phase of the signal generator so that the 6th signal of the output waveform reaches its maximum. Then measure the burst phase when this maximum is reached. ($-\theta_{\text{TINT}} [^\circ]$)</p> <p>(4) Change the voltage of the tint adjustment terminal (pin 28) to 3.9V. Then measure it.</p>
29	PAL/NTSC Select Threshold Voltage	$V_{P/N}$	<p>(1) Observe the output waveform of the R-Y output terminal (pin 16).</p> <p>(2) Raise the voltage of the tint adjustment terminal (pin 28) up from 0V. Then measure the voltage of the tint adjustment terminal (pin 28) when the color difference signal modulation mode is switched from PAL to NTSC. ($V_{P/N}$ [V])</p>

Sync. processing

NOTE	CHARACTERISTIC	SYMBOL	MEASUREMENT METHOD
30	Sync. Separation Current Sensitivity	I_{IN5}	(1) Connect an ammeter and DC power supply in series between the sync. input terminal (pin 5) and the GND. (2) Observe the output pulse of the VP output terminal (pin 46). (3) While lowering the voltage of the DC power supply beginning with 3.0V, measure the value of the ammeter when the output pulse period of the VP output terminal (pin 46) changes from 353H to 261.5H. (I_{IN5} [μ A])
31	H. AFC Phase Detection Current	I_{HDet}	(1) Connect a 1k Ω resistor and a DC voltmeter in series between the H. AFC filter 1 terminal (pin 2) and GND. (2) Input a composite sync. signal into the sync. separation input terminal (pin 5). Then observe the waveform of the H. AFC filter 1 terminal (pin 2). (3) Adjust the voltage of the DC power supply so that the waveform is vertically symmetrical. (4) Measure the zero-peak value of the waveform. (V_{IDet} [mV]) (5) I_{HDet} [μ A] = $\frac{V_{IDet}}{1 [k\Omega]}$
32	Phase Detector Inactive Period	T_s	(1) Input a composite signal into the sync. separation input terminal (pin 5). (2) Apply 5.0V to the YNR terminal (pin 26) through a 10k Ω resistor. (3) While observing the waveform of the YNR terminal (pin 26), measure the period when the pulse is inactive. (T_s (H))
33	2nd AFC Active Period	AFC _{ON}	(1) Input a composite signal into the sync. separation input terminal (pin 5). (2) Observe the waveform of the flyback pulse input terminal (pin 45). (3) While increasing the storage time from 0. Measure the strage time until H. AFC goes to be lock. (AFC _{ON} [μ s])

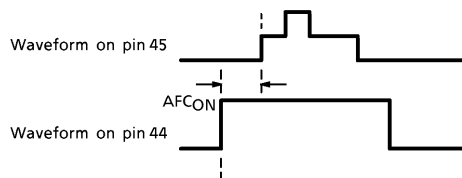

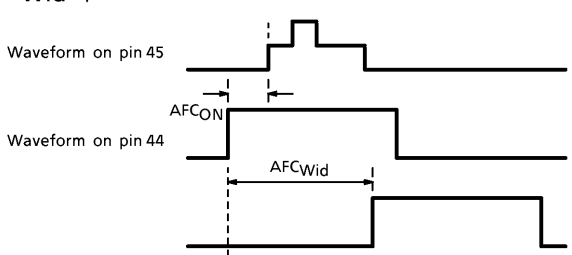
NOTE	CHARACTERISTIC	SYMBOL	MEASUREMENT METHOD
34	2nd AFC Control Range	AFCWid	<p>(1) Input a composite sync. signal into the sync. input terminal (pin 5).</p> <p>(2) Observe the waveform of the flyback pulse input terminal (pin 45).</p> <p>(3) Make sure that the storage time is equal to AFC_{ON}.</p> <p>(4) While increasing the storage time. Then measure the storage time until H. AFC goes to be un-lock. (AFCWid [μs])</p> 
35	Supply Voltage for 32f _H VCO in Active	V _{VCO}	<p>(1) Leave the V/C V_{CC} terminal (pin 12) open.</p> <p>(2) Connect a high-input-resistance probe between the ceramic resonator and resistor, which are connected in series between the 32f_H VCO terminal (pin 1) and the GND. Then observe the waveform.</p> <p>(3) Increase the voltage of Def. V_{CC} up from 0V, and measure the Def. V_{CC} voltage when the 32f_H VCO starts oscillating. (V_{VCO} [V])</p>
36	Supply Voltage for Horizontal Output in Active	V _{HON}	<p>(1) Leave the V/C V_{CC} terminal (pin 12) open.</p> <p>(2) Observe the output waveform of the horizontal output terminal (pin 44).</p> <p>(3) Increase the voltage of Def. V_{CC} up from 0V, and measure the Def. V_{CC} voltage when the horizontal output begins. (V_{HON} [V])</p>
37	Horizontal OSC Free-run Frequency	f _{HO}	<p>(1) Connect a capacitor (0.01μF) between the sync. input terminal (pin 5) and ground.</p> <p>(2) Measure the frequency of the output waveform of the horizontal output terminal (pin 44). (f_{HO} [kHz])</p>

NOTE	CHARACTERISTIC	SYMBOL	MEASUREMENT METHOD
38	Horizontal OSC Pull-in Range	PLAFC	<p>(1) Increase the horizontal frequency of the composite sync. signal that is input from the sync. input terminal (pin 5) beginning with 14.625kHz.</p> <p>(2) While observing the waveform of the flyback pulse input terminal (pin 45), measure the horizontal frequency until H. AFC goes to be lock. (f_{PLOW} [kHz])</p> <p>(3) Decrease the horizontal frequency of the composite sync. signal that is input from the sync. input terminal (pin 5) beginning with 16.625kHz.</p> <p>(4) While observing the waveform of the flyback pulse input terminal (pin 45), measure the horizontal frequency until H. AFC goes to be lock. (f_{PLHIGH} [kHz])</p> <p>(5) PR_{AFC} [kHz] = $f_{PLOW} - 15.625$ [kHz] or PR_{AFC} [kHz] = $f_{PRHIGH} - 15.625$ [kHz]</p>
39	Horizontal OSC Hold Range	LRAFC	<p>(1) Decrease the horizontal frequency of the composite sync. signal that is input from the sync. input terminal (pin 5) beginning with 15.625kHz.</p> <p>(2) While observing the waveform of the flyback pulse input terminal (pin 45), measure the horizontal frequency until H. AFC goes to be un-lock. (f_{LRLOW} [kHz])</p> <p>(3) Increase the horizontal frequency of the composite sync. signal that is input from the sync. input terminal (pin 5) beginning with 15.625kHz.</p> <p>(4) While observing the waveform of the flyback pulse input terminal (pin 45), measure the horizontal frequency until H. AFC goes to be un-lock. (f_{LRHIGH} [kHz])</p> <p>(5) PL_{AFC} [kHz] = $f_{LRLOW} - 15.625$ [kHz] or PL_{AFC} [kHz] = $f_{LRHIGH} - 15.625$ [kHz]</p>
40	AFC Control Sensitivity	β_{AFC}	<p>(1) Connect a capacitor (0.01μF) between the sync. input terminal (pin 5) and ground.</p> <p>(2) Connect a DC power supply to the H. AFC filter terminal (pin 2).</p> <p>(3) Measure the frequency of the horizontal output terminal (pin 44), then adjust the voltage of the DC power supply so that the measured frequency is 15.625kHz and the voltage is V_O [V].</p> <p>(4) Measure the frequency of the horizontal output terminal (pin 44) when the voltage of the H. AFC filter terminal (pin 2) is set to $V_O + 50$ [mV]. (f_{HIGH} [Hz])</p> <p>(5) Measure the frequency of the horizontal output terminal (pin 44) when the voltage of the H. AFC filter terminal (pin 2) is set to $V_O - 50$ [mV]. (f_{LOW} [Hz])</p> <p>(6) β_{AFC} [Hz/mV] = $\frac{f_{HIGH} - f_{LOW}}{100}$ [mV]</p>

NOTE	CHARACTERISTIC	SYMBOL	MEASUREMENT METHOD
41	Horizontal Pulse duty	T_{DUT}	Measure the pulse duty cycle from the output waveform of the horizontal output terminal (pin 44). (T_{DUT} [%])
42	Horizontal Pulse Level	V_{HL} V_{HH}	Measure the high-level and low-level voltages of the output waveform of the horizontal output terminal (pin 44). (V_{HL} [V] ; V_{HH} [V])
43	X-RAY Protection Threshold Voltage	V_{XON}	(1) Connect DC power supply to the X-RAY protection input terminal (pin 43). (2) While increase the voltage of the DC power supply, measure the DC voltage when the horizontal pulse from the horizontal output terminal (pin 44) stops. (V_{XON} [V])
44	X-RAY Protection Hold Voltage	V_{XHLD}	(1) Apply 5.0V to the X-RAY protection input terminal (pin 43), then stop this voltage application after operating the X-RAY protection circuit. (2) Decrease the Def. V_{CC} voltage, then increase it back to 9.0V. (3) Measure the voltage where the horizontal pulse remains idle even after the Def. V_{CC} voltage is returned to 9.0V. (V_{XHLD} [V])
45	Vertical Pulse Width	T_{VP}	While observing the output waveform of the VP output terminal (pin 46), measure the low-level period. (T_{VP} [H])
46	Vertical OSC Pull-in Range	PL_V	(1) Input a composite sync. signal into the sync. input terminal (pin 5). (2) While changing the vertical sync. period by 0.5H step, measure the vertical period immediately before the voltage of the station ID terminal (pin 25) decreases to 0V. (PL_V [H]) (3) When taking this measurement in the 50Hz mode, set the terminal voltage of the 1H delay line input terminal (pin 21) to 6.0V. When taking a measurement in the 60Hz mode, set the terminal voltage to 3.0V.
47	Vertical OSC Free-run Frequency	T_{VO}	(1) Connect a capacitor (0.01 μ F) between the sync. input terminal (pin 5) and ground. (2) While observing the output waveform of the VP output terminal (pin 46), measure the vertical free-run oscillation cycle. (T_{VO} [H]) (3) When taking this measurement in the 50Hz mode, set the terminal voltage of the 1H delay line input terminal (pin 21) to 6.0V. When taking a measurement in the 60Hz mode, set the terminal voltage to 3.0V.

NOTE	CHARACTERISTIC	SYMBOL	MEASUREMENT METHOD
48	Vertical OSC Pull-in Range Select Voltage	V_{SW50} V_{SW60}	<p>(1) Input a composite sync. signal with a vertical frequency of 60Hz from the sync. input terminal (pin 5).</p> <p>(2) Connect a DC power supply to the 1H delay line input terminal (pin 21). Then increase the terminal voltage beginning with 4.5V.</p> <p>(3) While measuring the terminal voltage of the station ID terminal (pin 25), measure the terminal voltage of the 1H delay line input terminal (pin 21) when the station ID terminal voltage decreases to 0V. (V_{SW50} [V])</p> <p>(4) Connect a capacitor (0.01μF) between the sync. input terminal (pin 5) and ground.</p> <p>(5) Connect a DC power supply to the 1H delay line input terminal (pin 21). Then decrease the terminal voltage beginning with 4.5V.</p> <p>(6) While measuring the VP pulse period that is output from the VP output terminal (pin 46), measure the terminal voltage of the 1H delay line input terminal (pin 21) when the pulse period changes from 353H to 261.5H. (V_{SW60} [H])</p>
49	Vertical Frequency Identification Voltage	V_{ID50} V_{ID60}	<p>(1) Input a composite sync. signal with a vertical frequency of 50Hz from the sync. input terminal (pin 5).</p> <p>(2) Measure the terminal voltage of the 1H delay line output terminal (pin 24). (V_{ID50} [V])</p> <p>(3) Input a composite sync. signal with a vertical frequency of 60Hz from the sync. input terminal (pin 5).</p> <p>(4) Measure the terminal voltage of the 1H delay line output terminal (pin 24). (V_{ID60} [V])</p>

Linear RGB Processing

NOTE	CHARACTERISTIC	SYMBOL	MEASUREMENT METHOD
50	RGB Input Dynamic Range	Dr _{RGB}	<p>(1) Set the contrast adjustment terminal (pin 30) to 2.5V, the brightness adjustment terminal (pin 31) to 1.5V, and the Ys terminal (pin 35) to 2.0V.</p> <p>(2) Measure the terminal voltage of the R input terminal (pin 32) using a high-input-resistance voltmeter. (V_{CLMP} [V])</p> <p>(3) Connect a DC power supply to the R input terminal (pin 32). Then apply the same voltage as V_{CLMP}.</p> <p>(4) While measuring the output voltage of the R output terminal (pin 37), increase the voltage of the DC power supply that is connected to the R input terminal (pin 32).</p> <p>(5) Measure the voltage of the DC power supply connected to the R input terminal (pin 32) when the output voltage of the R input terminal (pin 37) becomes constant and remains so even when you increase the voltage of the DC power supply. (V [V]) Dr_{RGB} [V_{p-p}] = V - V_{CLMP}</p> <p>(6) Take the same measurement for the G input terminal (pin 33) and B input terminal (pin 34).</p>
51	Gain (RGB Input→RGB Output)	G _{IO}	<p>(1) Set the contrast adjustment terminal (pin 30) to 5.0V, the brightness adjustment terminal (pin 31) to 1.5V, and the Ys terminal (pin 35) to 2.0V.</p> <p>(2) Input to the B input terminal (pin 34) a square wave with a 200mV amplitude and a 50% duty cycle that is synchronized to the horizontal sync. signal. (This square wave must be such that the horizontal sync. pulse is at the center of its low-level width.)</p> <p>(3) Measure the amplitude of the B output terminal (pin 41). (V_O [mV])</p> <p>(4) G_{IO} [dB] = $20 \log \frac{V_O}{200}$</p>
52	Contrast Control Limiting Level	G _{LIMIT}	<p>(1) Set the contrast adjustment terminal (pin 30) to 5.0V, the brightness adjustment terminal (pin 31) to 1.5V, and the Ys terminal (pin 35) to 2.0V.</p> <p>(2) Input a signal with a 0.5V_{p-p} amplitude into the B input terminal (pin 34) and measure the output amplitude of the B output terminal (pin 41). (V₀ [V_{p-p}])</p> <p>(3) Set the contrast adjustment terminal (pin 30) to 0V, and set the Ys terminal (pin 35) to 9.0V.</p> <p>(4) Input a signal with a 0.5V_{p-p} amplitude into the B input terminal (pin 34) and measure the output amplitude of the B output terminal (pin 41). (V₁ [V_{p-p}])</p> <p>(5) G_{LIMIT} [dB] = $20 \log \frac{V_1}{V_0}$</p>

NOTE	CHARACTERISTIC	SYMBOL	MEASUREMENT METHOD
53	Switching Threshold Voltage	$V_{TV/TXT}$ $V_{TX/OSD}$	<p>(1) Set the contrast adjustment terminal (pin 30) to 5.0V, the brightness adjustment terminal (pin 31) to 1.5V, and the Ys terminal (pin 35) to 0V.</p> <p>(2) Input a signal (any signal) from the B input terminal (pin 34).</p> <p>(3) Input a signal (any signal) from the luminance input terminal (pin 6).</p> <p>(4) Connect a DC power supply to the Ys terminal (pin 35).</p> <p>(5) While observing the output waveform of the B output terminal (pin 41), increase the voltage of the DC power supply.</p> <p>(6) Measure the voltage of the Ys terminal (pin 35) when the output waveform of the B output terminal (pin 41) is switched from the signal of the luminance input terminal (pin 6) to that of the B input terminal (pin 34). ($V_{TV/TX}$ [V])</p> <p>(7) Set the contrast adjustment terminal (pin 30) to 0V.</p> <p>(8) While observing the output waveform of the B output terminal (pin 41), increase the voltage of the DC power supply.</p> <p>(9) Measure the voltage of the Ys terminal (pin 35) when the output waveform of the B output terminal (pin 41) has a large amplitude. ($V_{TV/OSC}$ [V])</p>
54	Switching Time (TV→RGB) (TXT→TV)	$t_{TV/TXT}$ $t_{TXT/TV}$	<p>(1) Set the contrast adjustment terminal (pin 30) to 5.0V, and set the brightness adjustment terminal (pin 31) to 1.5V.</p> <p>(2) Connect a capacitor (0.01μF) between the luminance input terminal (pin 6) and ground, and connect a capacitor (0.01μF) between the chroma input terminal (pin 19) and ground.</p> <p>(3) Input the test signal (A) into the B input terminal (pin 34).</p> <p>(4) Input the test signal (A) into the Ys terminal (pin 35).</p> <p>(5) While observing the output waveform of the B output terminal (pin 41), measure the switching time.</p>

INPUT SIGNAL FOR MEASUREMENT OF OSD PERFORMANCE

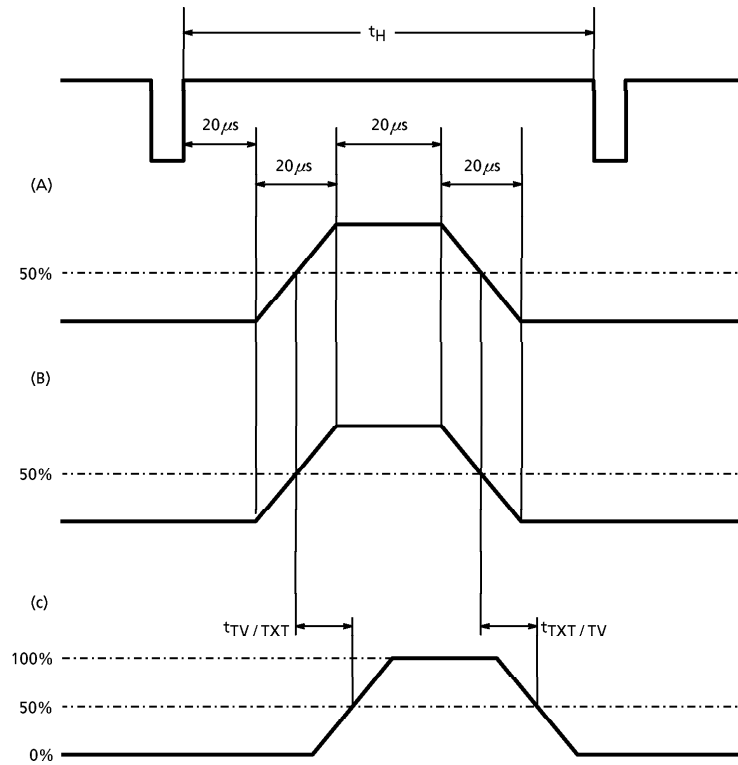

APPLICATION EXAMPLE CIRCUIT

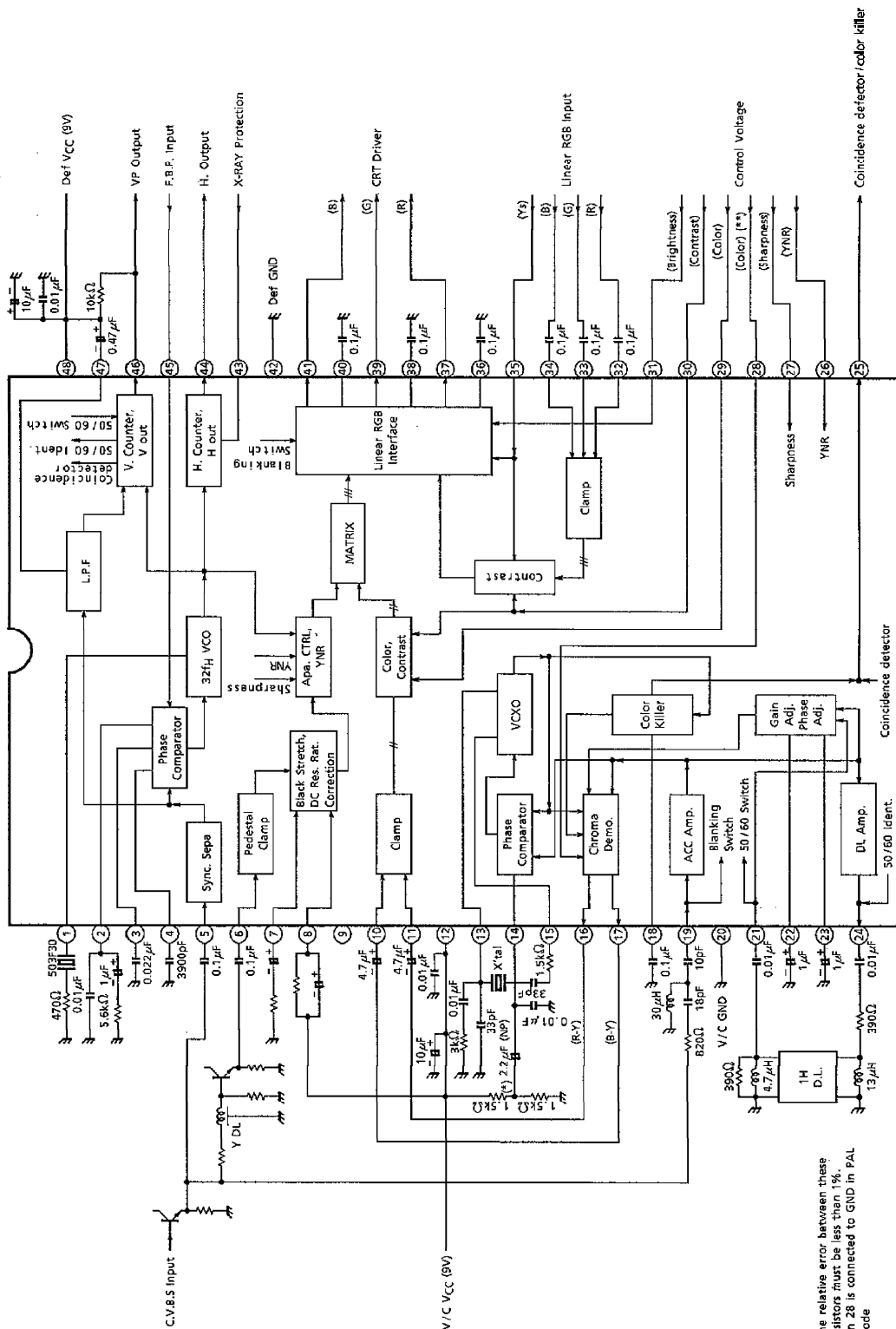

(*) The relative error between these resistors must be less than 1%.
 (***) Pin 28 is connected to GND in PAL mode

OUTLINE DRAWING
SDIP48-P-600-1.78

Unit : mm

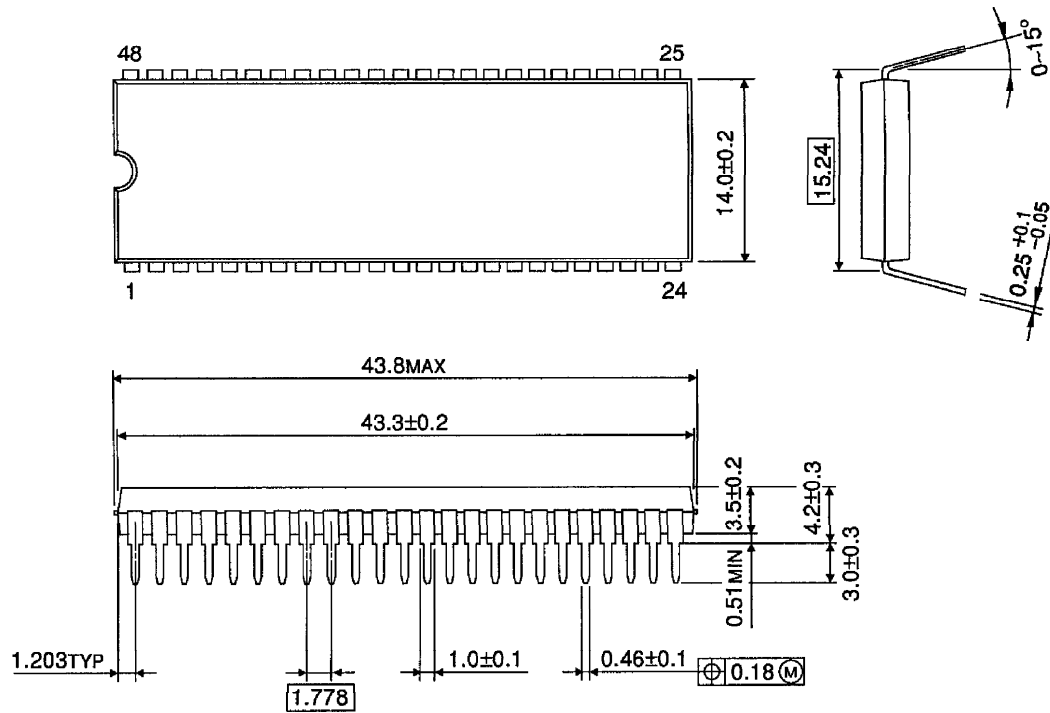

Weight : 4.81g (Typ.)