

TOSHIBA BIPOLAR LINEAR INTEGRATED CIRCUIT SILICON MONOLITHIC

TA8411L

STEPPING MOTOR SYSTEM DRIVER

The TA8411L is Stepping Motor System Driver IC incorporates Dual Bipolar Stepping Motor Drivers, DC Motor Driver and Serial to Parallel Signal Conversion Circuit (12 bit Serial to Parallel Shift Resistor with Latch) which control the 3 Output Drivers states by means of Input Serial Signal trains.

FEATURES

- 2 Bipolar Stepping Motors and 1 Brush DC Motor (or Solenoid) are controlled by input serial signal trains and latch signals.
- Output Current up to 0.8A (for Stepper) and 0.6A (for DC Motor).
- PWM Chopper type Stepping Motor Drivers.
- All C-MOS Compatible Inputs.
- Operating Supply Voltage : $V_{M1, 2} = 0 \sim 27V$
 $V_{CC} = 4.5 \sim 5.5V$

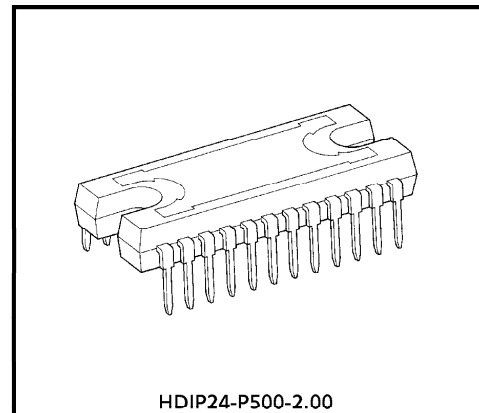

Weight : 4.30g (Typ.)

961001EBA1

- TOSHIBA is continually working to improve the quality and the reliability of its products. Nevertheless, semiconductor devices in general can malfunction or fail due to their inherent electrical sensitivity and vulnerability to physical stress. It is the responsibility of the buyer, when utilizing TOSHIBA products, to observe standards of safety, and to avoid situations in which a malfunction or failure of a TOSHIBA product could cause loss of human life, bodily injury or damage to property. In developing your designs, please ensure that TOSHIBA products are used within specified operating ranges as set forth in the most recent products specifications. Also, please keep in mind the precautions and conditions set forth in the TOSHIBA Semiconductor Reliability Handbook.
- The products described in this document are subject to foreign exchange and foreign trade control laws.
- The information contained herein is presented only as a guide for the applications of our products. No responsibility is assumed by TOSHIBA CORPORATION for any infringements of intellectual property or other rights of the third parties which may result from its use. No license is granted by implication or otherwise under any intellectual property or other rights of TOSHIBA CORPORATION or others.
- The information contained herein is subject to change without notice.

BLOCK DIAGRAM

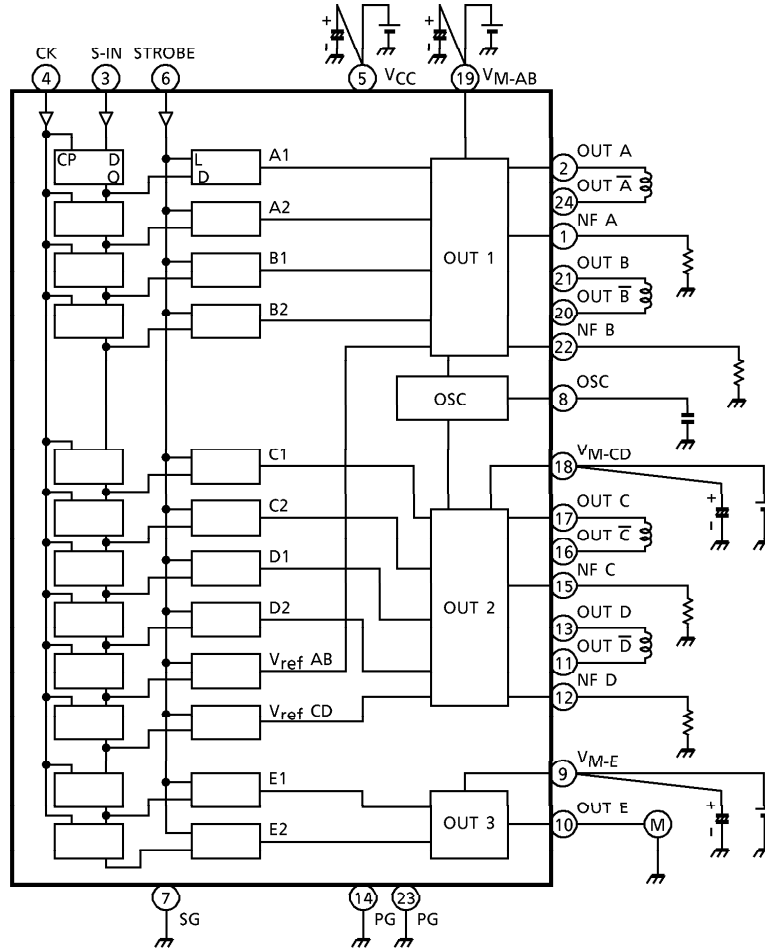

(Note 1) Capacitance connect to each Power Supply Terminal is required to change to optimum value for noise elimination and also required to connect directly to each Power Supply Terminal (V_{CC} , V_{M1} , 2) and the corresponding GND Terminal (See Table 1) for stable operations.

Table 1

GND	POWER SUPPLY
Pin⑦ (SG)	Pin⑤ (V_{CC})
Pin⑳ (PG)	Pin⑱ (V_{M-AB})
Pin⑭ (PG)	Pin⑱ (V_{M-CD}), Pin⑨ (V_{M-E})

(Note 2) Heat Fin is connect to GND terminal with Low Impedance.

PIN FUNCTION

PIN No.	SYMBOL	FUNCTIONAL DESCRIPTION
1	NF A	A channel current detection output terminal.
2	OUT A	OUTPUT A
3	S-IN	Serial signal input terminal.
4	CK	Clock signal input terminal.
5	V _{CC}	Supply voltage terminal for control circuit.
6	STROBE	STROBE signal input terminal.
7	SG	Signal GND terminal.
8	OSC	Internal osc frequency setting terminal.
9	V _{M-E}	E channel power supply input terminal.
10	OUT E	E channel output terminal. (pushpull output)
11	OUT \bar{D}	OUTPUT \bar{D}
12	NF D	D channel current detection output terminal.
13	OUT D	OUTPUT D
14	PG	Power GND terminal.
15	NF C	C channel current detection output terminal.
16	OUT \bar{C}	OUTPUT \bar{C}
17	OUT C	OUTPUT C
18	V _{M-CD}	Supply voltage terminal for C channel D channel.
19	V _{M-AB}	Supply voltage terminal for A channel B channel.
20	OUT \bar{B}	OUTPUT \bar{B}
21	OUT B	OUTPUT B
22	NF B	B channel current detection output terminal.
23	PG	Power GND terminal.
24	OUT \bar{A}	OUTPUT \bar{A}

PIN CONNECTION

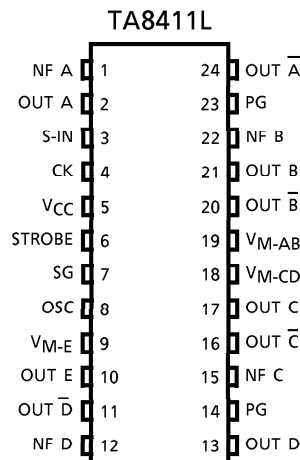

INPUT SERIAL PULSE TRAIN (PIN③) AND POWER OUTPUT STATES

SERIAL INPUT SIGNAL TRAIN		CONTROL	OPERATION																														
↑	1	E2	<table border="1"> <thead> <tr> <th colspan="2">INPUT</th> <th>OUTPUT</th> <th rowspan="2">MODE</th> </tr> <tr> <th>E1</th> <th>E2</th> <th>E</th> </tr> </thead> <tbody> <tr> <td>L</td> <td>L</td> <td>∞</td> <td>STOP</td> </tr> <tr> <td>H</td> <td>L</td> <td>H</td> <td>CW/CCW</td> </tr> <tr> <td>L</td> <td>H</td> <td>L</td> <td>Brake</td> </tr> <tr> <td>H</td> <td>H</td> <td>∞</td> <td>STOP</td> </tr> </tbody> </table>	INPUT		OUTPUT	MODE	E1	E2	E	L	L	∞	STOP	H	L	H	CW/CCW	L	H	L	Brake	H	H	∞	STOP							
	INPUT			OUTPUT	MODE																												
	E1	E2		E																													
	L	L		∞	STOP																												
	H	L	H	CW/CCW																													
	L	H	L	Brake																													
	H	H	∞	STOP																													
	2	E1	DC Motor Control																														
	3	V _{ref} CD	Stepping Motor 2 Chopping Rate Control (V _{ref} CD)	V _{ref} = 0.7V Typ. (at "H" Mode) = 0.55V Typ. (at "L" Mode)																													
	4	V _{ref} AB	Stepping Motor 1 Chopping Rate Control (V _{ref} AB)																														
	5	D2	Stepping Motor 2 Control (OUT C, D)	<table border="1"> <thead> <tr> <th colspan="2">INPUT</th> <th colspan="2">OUTPUT</th> <th rowspan="2">MODE</th> </tr> <tr> <th>A1</th> <th>A2</th> <th>A</th> <th>\bar{A}</th> </tr> </thead> <tbody> <tr> <td>L</td> <td>L</td> <td>∞</td> <td>∞</td> <td>STOP</td> </tr> <tr> <td>H</td> <td>L</td> <td>H</td> <td>L</td> <td>CW/CCW</td> </tr> <tr> <td>L</td> <td>H</td> <td>L</td> <td>H</td> <td>CCW/CW</td> </tr> <tr> <td>H</td> <td>H</td> <td>∞</td> <td>∞</td> <td>STOP</td> </tr> </tbody> </table>	INPUT		OUTPUT		MODE	A1	A2	A	\bar{A}	L	L	∞	∞	STOP	H	L	H	L	CW/CCW	L	H	L	H	CCW/CW	H	H	∞	∞	STOP
	INPUT				OUTPUT		MODE																										
A1	A2	A			\bar{A}																												
L	L	∞			∞	STOP																											
H	L	H	L	CW/CCW																													
L	H	L	H	CCW/CW																													
H	H	∞	∞	STOP																													
6	D1	Stepping Motor 1 Control (OUT A, B)	B1, B2 → B, \bar{B} C1, C2 → C, \bar{C} D1, D2 → D, \bar{D} are all the same.																														
7	C2																																
8	C1																																
9	B2																																
10	B1																																
11	A2																																
12	A1																																

∞ : High impedance

INPUT SERIAL PULSE TRAIN TIMING CHART

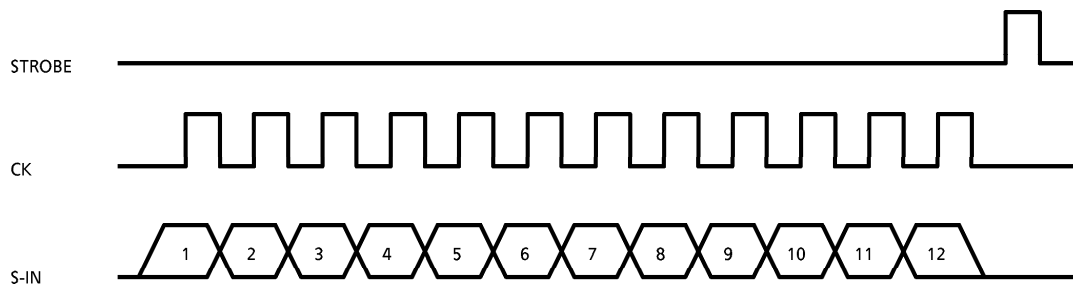

OUTPUT STAGE 1, 2 1/2 CIRCUIT

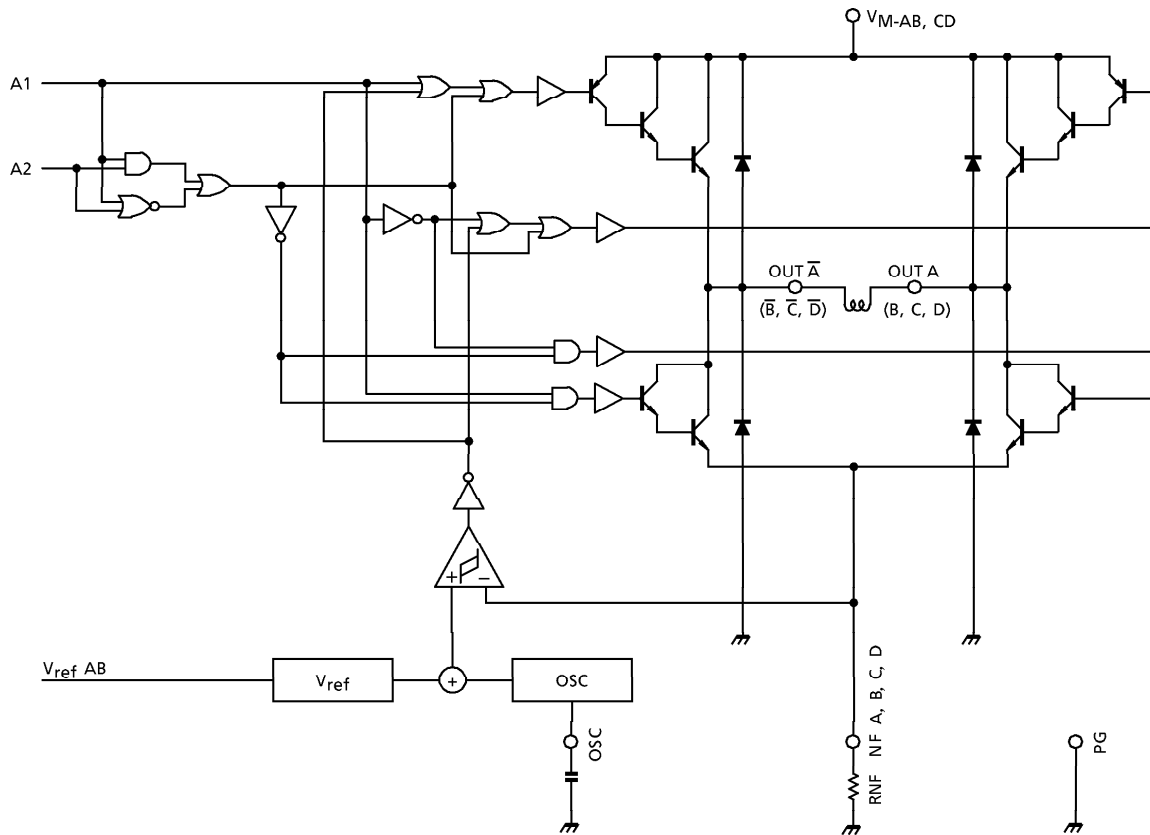

FUNCTION (Comp.+ > Comp.-)

A1	A2	A	Ā	MODE
L	L	∞	∞	STOP
H	L	H	L	CW / CCW
L	H	L	H	CCW / CW
H	H	∞	∞	STOP

∞ : High impedance

(Note 1) In case of Comp.+ < Comp.-, Upper side Power Transistor turned off.

(Note 2) Free wheeling diode connects between Output A terminal and GND is required for stable operations. And also recommend to connect free wheeling diodes other Output terminals for reliable operations.

OUTPUT STAGE 3

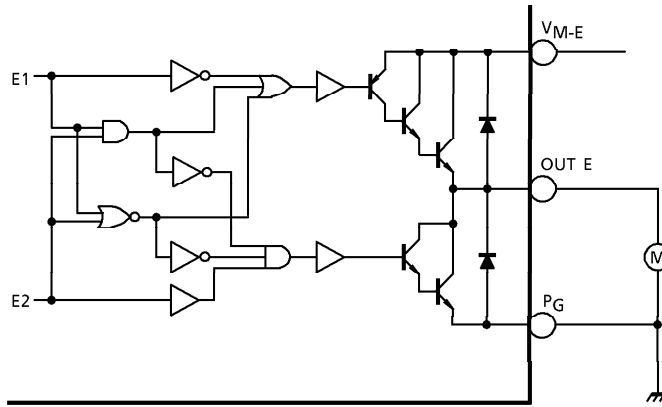

FUNCTION

E1	E2	E	MODE
L	L	∞	STOP
H	L	H	CW
L	H	L	BRAKE
H	H	∞	STOP

∞ : High impedance

INPUT STAGE (CK, S-IN, STROBE)

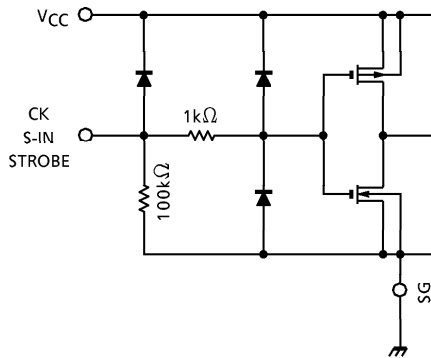

OSC STAGE (OSC)

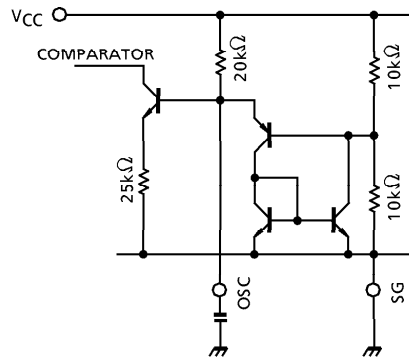

$$f_{osc} = \frac{1}{21.4 C_{OSC}} \text{ (kHz)}$$

$C_{OSC} : \mu\text{F}$

MAXIMUM RATINGS (Ta = 25°C)

CHARACTERISTIC	SYMBOL	RATING	UNIT
Supply Voltage (Motor)	V_M	30	V
Supply Voltage (Control)	V_{CC}	5.5	V
Input Voltage	V_{IN}	5.5	V
Output Current	I_{O1}, I_{O2}	0.8	A
	I_{O3}	0.6	
Power Dissipation	P_D	16.2 (Note 1)	W
		2.5 (Note 2)	
Operating Temperature	T_{opr}	- 40~85	°C
Storage Temperature	T_{stg}	- 55~150	°C

- (Note 1) $T_c = 85^\circ\text{C}$
- (Note 2) No heat sink

RECOMMENDED OPERATION CONDITION

CHARACTERISTIC		SYMBOL	TEST CONDITION	MIN.	TYP.	MAX.	UNIT
Supply Voltage (Control)		V _{CC}	—	4.5	5.0	5.5	V
Supply Voltage (Motor)		V _M	—	21.6	24	26.4	V
Input Voltage		V _{IN}	—	0	—	V _{CC}	V
Output Current	I _{OUT} A, B, C, D	I _{OUT}	Ta = 0~70°C V _{CC} = 5V V _M = 24V	—	—	0.7	A
	I _{OUT} E			—	—	0.4	
Clock Frequency		f _{CK}		—	—	1.0	MHz
		f _{STROBE}		—	—	1.0	
Clock Pulse Width		t _w CK		500	—	—	ns
		t _w STROBE		500	—	—	
Data Set Up Time		t _{su}		250	—	—	ns
Data Hold Time		t _H		250	—	—	ns
PWM Oscillation Frequency		f _{PWM}		20	—	100	kHz

ELECTRICAL CHARACTERISTICS

Output stage (Ta = 25°C, V_{CC} = 5V, V_M = 24V)

CHARACTERISTIC		SYMBOL	TEST CIR-CUIT	TEST CONDITION	MIN.	TYP.	MAX.	UNIT	
Operation Power Supply Voltage		V _{M (opr)}	—	—	0	—	27	V	
Saturation Voltage	AB DC	V _{CE (SAT)} Upper	1	I _{OUT} = 0.7A	Output - V _{CC}	—	2.0	2.5	V
				I _{OUT} = 0.5A		—	1.8	2.3	
	AB CD	V _{CE (SAT)} Lower	1	I _{OUT} = 0.7A	Output - NF	—	1.5	2.0	
				I _{OUT} = 0.5A		—	1.3	1.8	
	E	V _{CE (SAT)} Upper	1	I _{OUT} = 0.5A	Output - V _{CC}	—	1.8	2.3	
				I _{OUT} = 0.3A		—	1.7	2.2	
	E	V _{CE (SAT)} Lower	1	I _{OUT} = 0.5A	Output - NF	—	1.5	2.0	
				I _{OUT} = 0.3A		—	1.2	1.7	
Output Leak Current		I _{OL-H}	2	V _{CE} = 30V	—	—	50	μA	
		I _{OL-L}			—	—	50		
Clamp Diode Forward Voltage	AB CD	V _{F-U}	3	I _F = 700mA	Output A~D	—	1.6	2.0	V
		V _{F-L}				—	1.6	2.0	
	E	V _{F-U}	3	I _F = 500mA	Output E	—	1.5	1.9	
		V _{F-L}				—	1.7	2.1	
Propagation Delay Time (ST-OUT)		t _p	7	—	—	600	—	ns	

Small signal stage (Ta = 25°C, VCC = 5V, VM = 24V)

CHARACTERISTIC		SYMBOL	TEST CIRCUIT	TEST CONDITION		MIN.	TYP.	MAX.	UNIT
Operating Supply Voltage		VCC (opr)	—	—		4.5	—	5.5	V
Quiescent Current		ICC1	4	VCC = 5V Output Open	Output off mode	—	26.0	40	mA
		ICC2			Output on mode : output stage 1 or 2	—	26.0	40	
		ICC3			Output on mode : output stage 1 and 2	—	24.0	37	
		ICC4			Output on mode : output stage 3	—	25.0	38	
Input Voltage	"H" Level	VIN H	—	VCC = 5.0V	CK, S-IN STROBE	3.5	—	VCC	V
	"L" Level	VIN L				−0.4	—	1.5	
Input Current	"H" Level	IIN H	5	VCC = 5.0V	VIN H = 5.5V	—	55	150	μA
					VIN H = 3.5V	—	35	100	
	"L" Level	IIN L			VIN L = 1.5V	—	15	50	
Vref	"H" Level	Vref H	6	Tj = −40~125°C COSC = 3300pF RNF = 3.3Ω L = 19.5mH	Vref IN = "H"	0.6	0.7	0.8	V
	"L" Level	Vref L			Vref IN = "L"	0.45	0.55	0.65	
Vref Level Differential Voltage		ΔVref	6	Vref (H) − Vref (L)		—	0.15	—	V
Reset Voltage		VCCR	—	—		3.4	3.9	4.4	V
PWM Oscillation Frequency		fpWM	—	—		10	—	200	kHz
Clock Frequency		fCK	7	—		—	—	1.5	MHz
		fSTROBE	7	—		—	—	1.5	
Min. Clock Width		tCK	7	—		340	—	—	ns
		tSTROBE	7	—		340	—	—	
Data Set Up Time		tSU	7	—		170	—	—	ns
Data Hold Up Time		tH	7	—		170	—	—	ns

TEST CIRCUIT 1. $V_{CE(SAT)}$ Upper, Lower

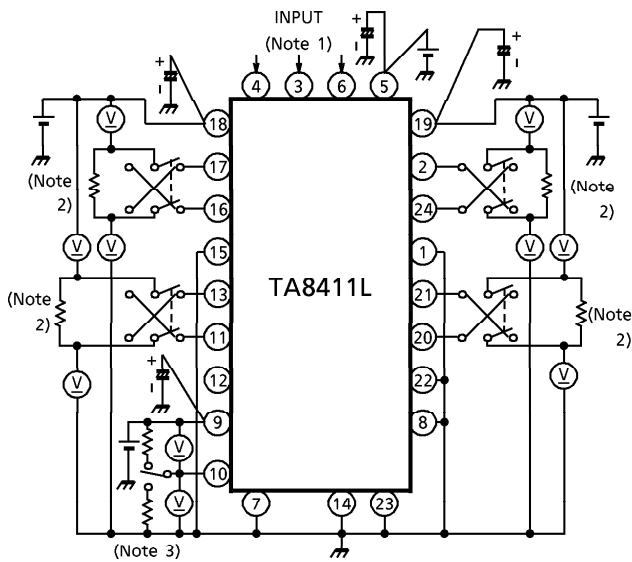

- (Note 1) Sets Output Transistor active with Input mode select.
- (Note 2) Calibrate Output Current becomes 0.5A (or 0.7A) with this resistor.
- (Note 3) Calibrate Output Current becomes 0.3A (or 0.5A) with this resistor.

TEST CIRCUIT 2. I_{OL-H} , I_{OL-L}

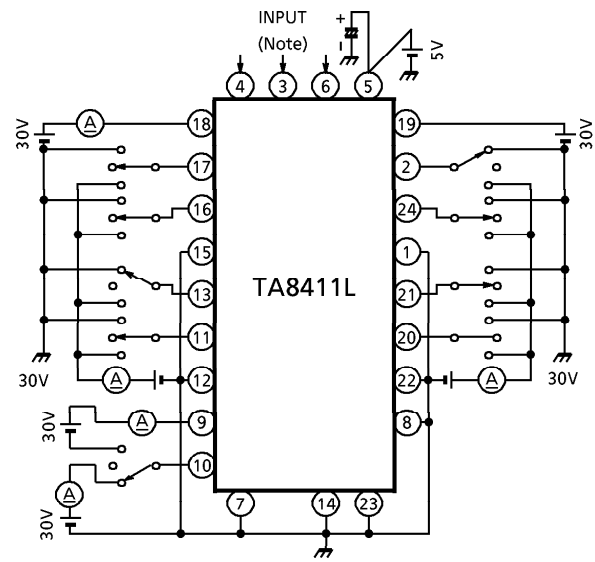

- (Note) All "L" level S-IN signal, normal CK and Strobe signals are required to measure.

TEST CIRCUIT 3. V_{F-U} , V_{F-L}

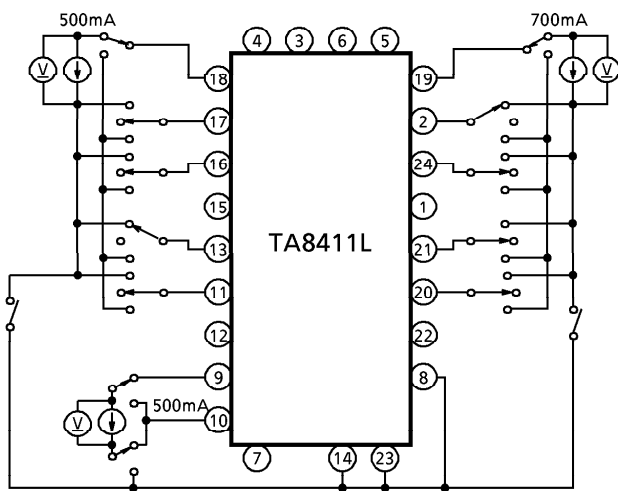

- (Note) Not to take a GND with any non-connecting Pins.

TEST CIRCUIT 4. $I_{CC1, 2, 3, 4}$

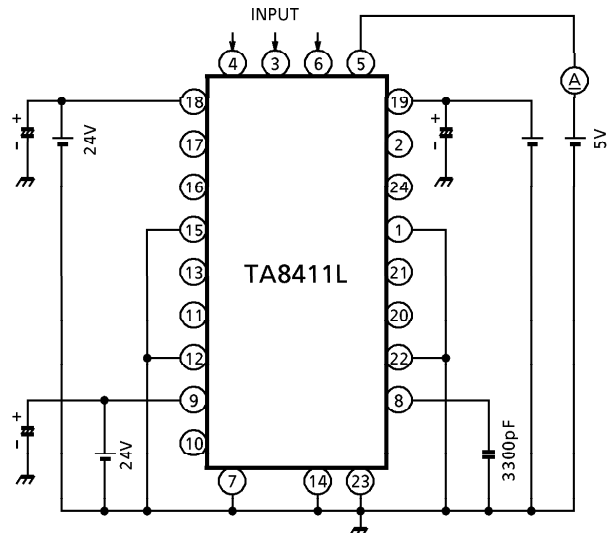

TEST CIRCUIT 5. I_{INH} , I_{INL}

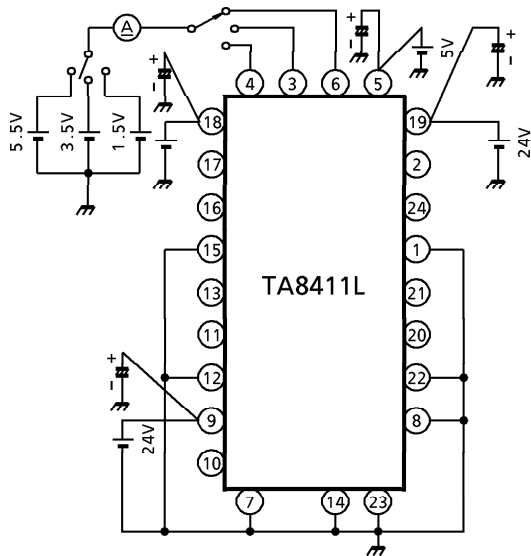

TEST CIRCUIT 6. V_{ref-H} , V_{ref-L} , ΔV_{ref}

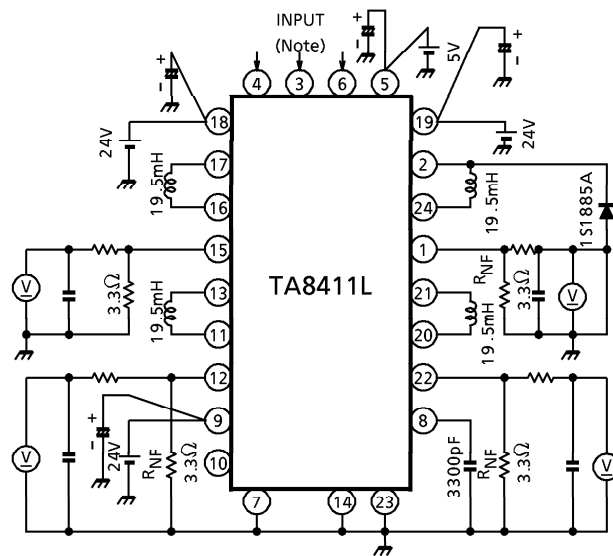

(Note) Hold the state (2 Phase excitation mode) and measure.

AC ELECTRICAL CHARACTERISTIC MEASUREMENT WAVEFORM

7-1 CK - S-IN

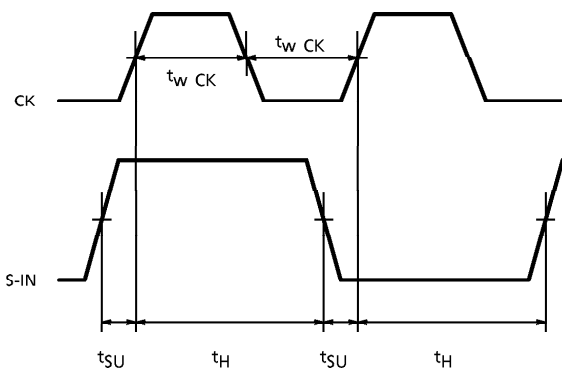

7-2 STROBE-OUT

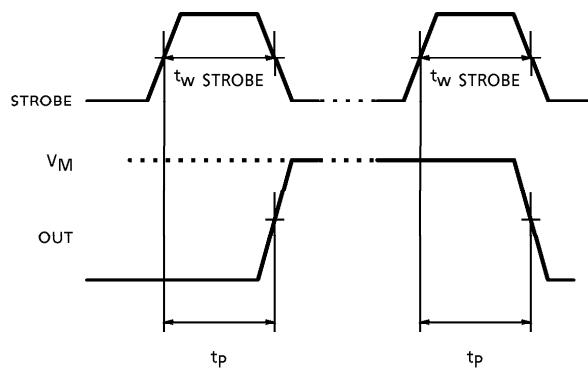

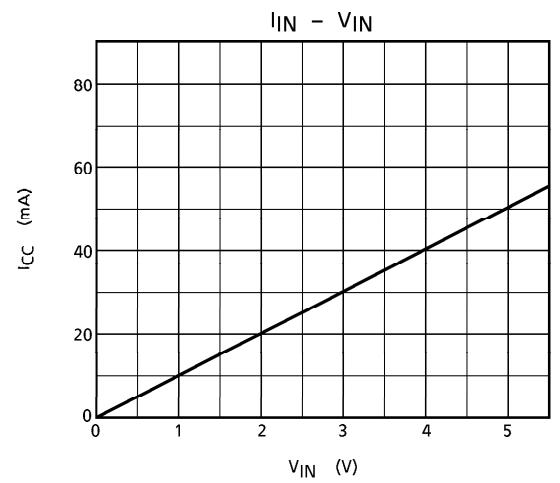
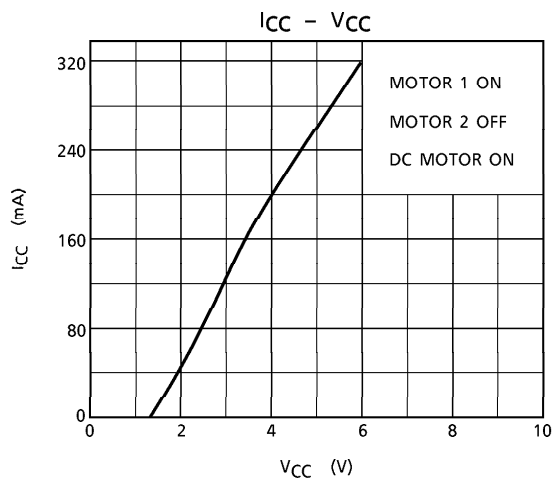
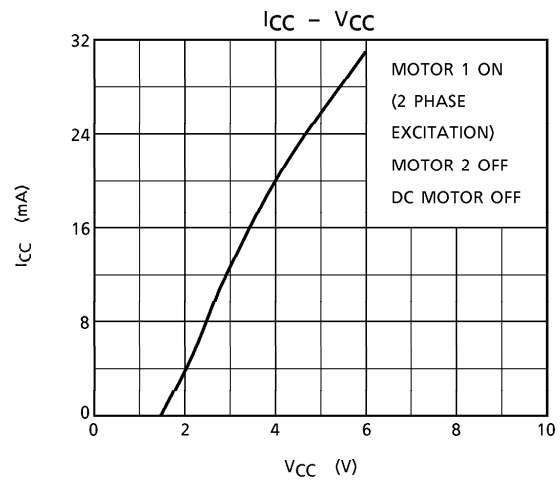
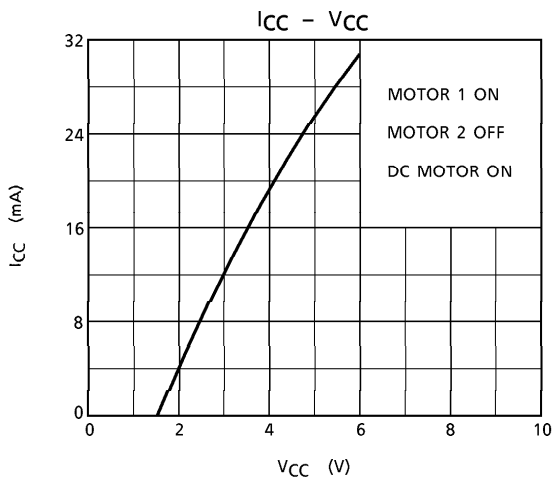
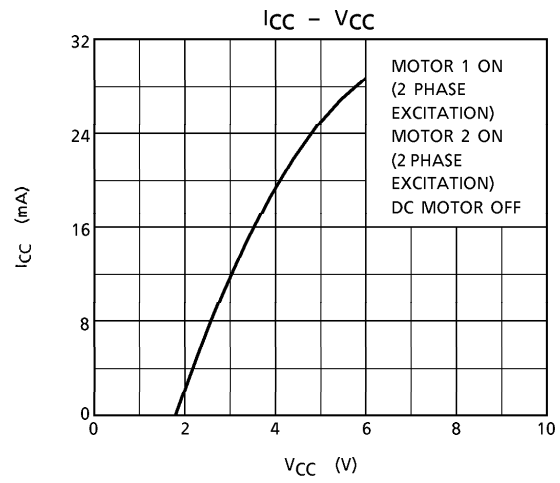
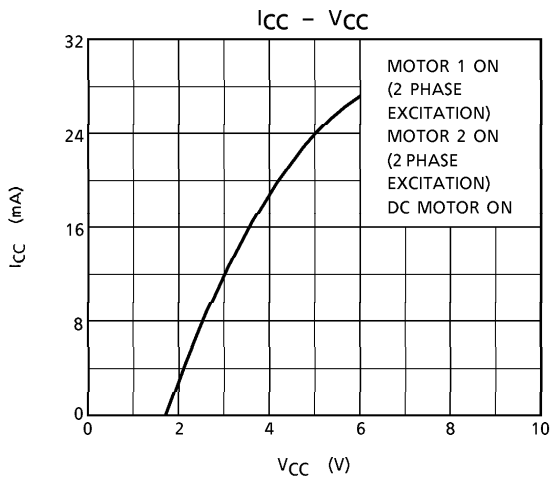

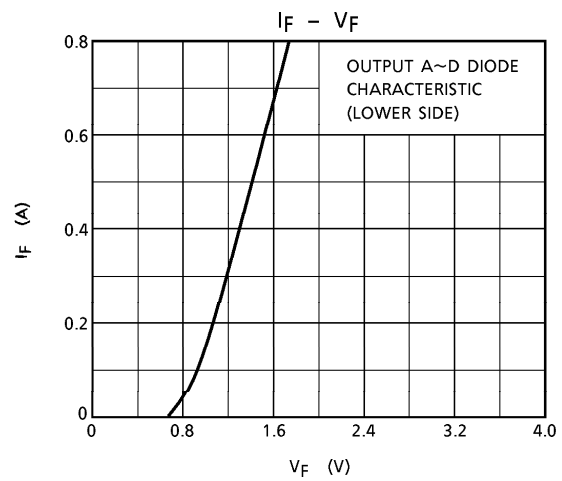
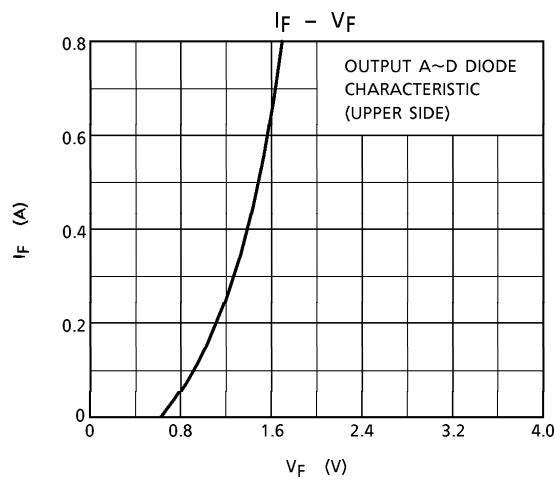
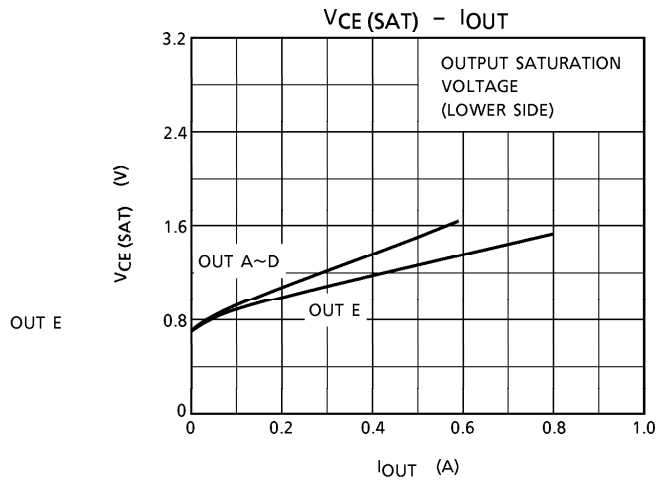
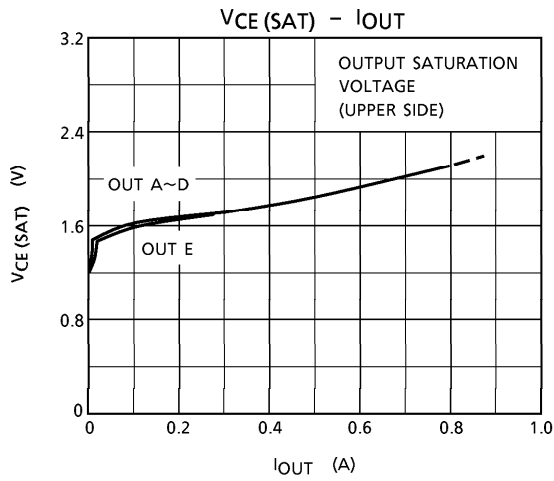
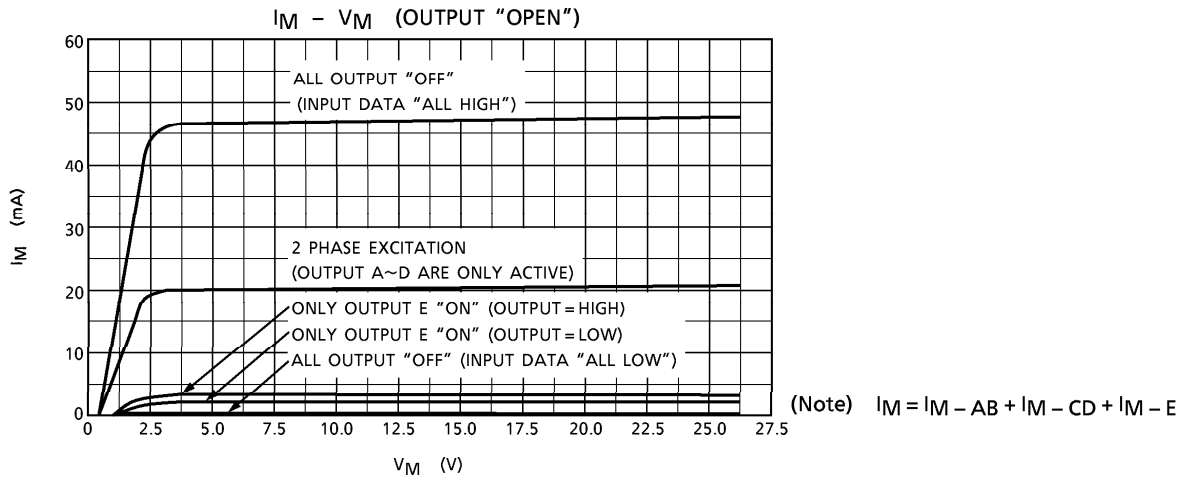

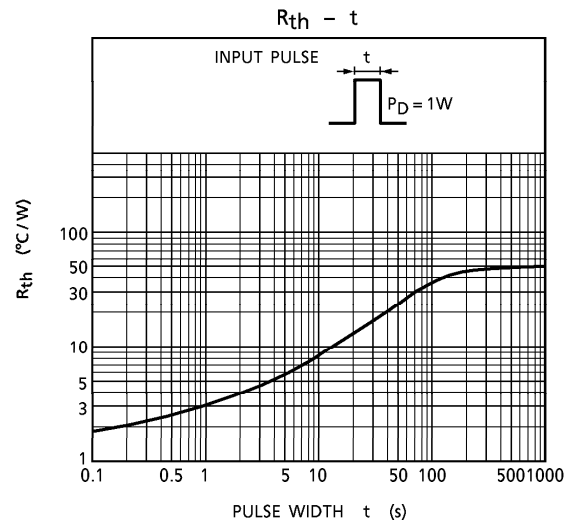
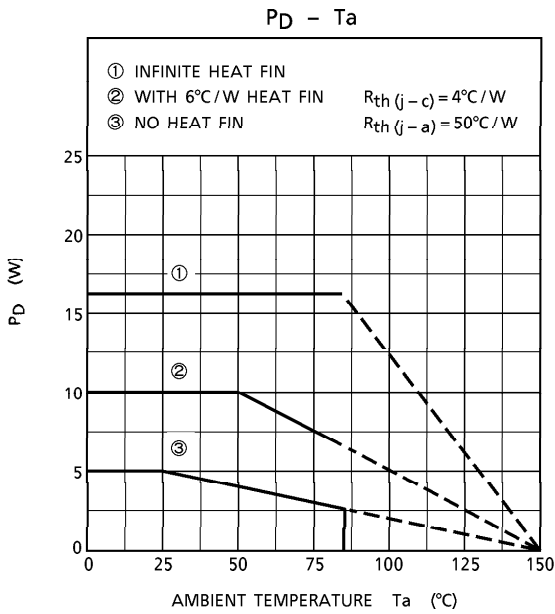
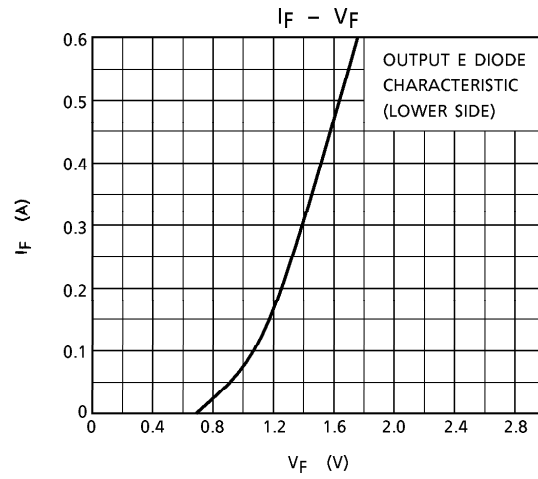
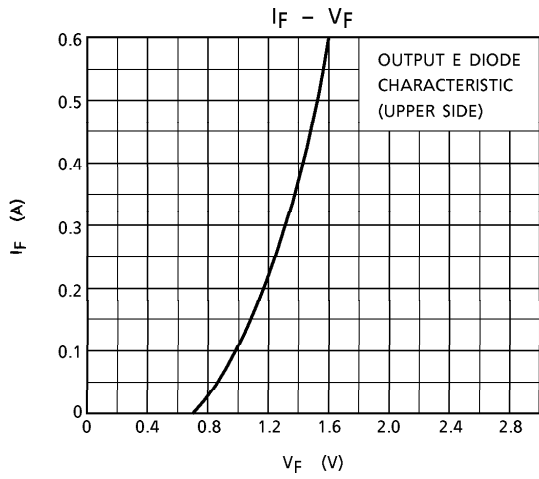

APPLICATION CIRCUIT

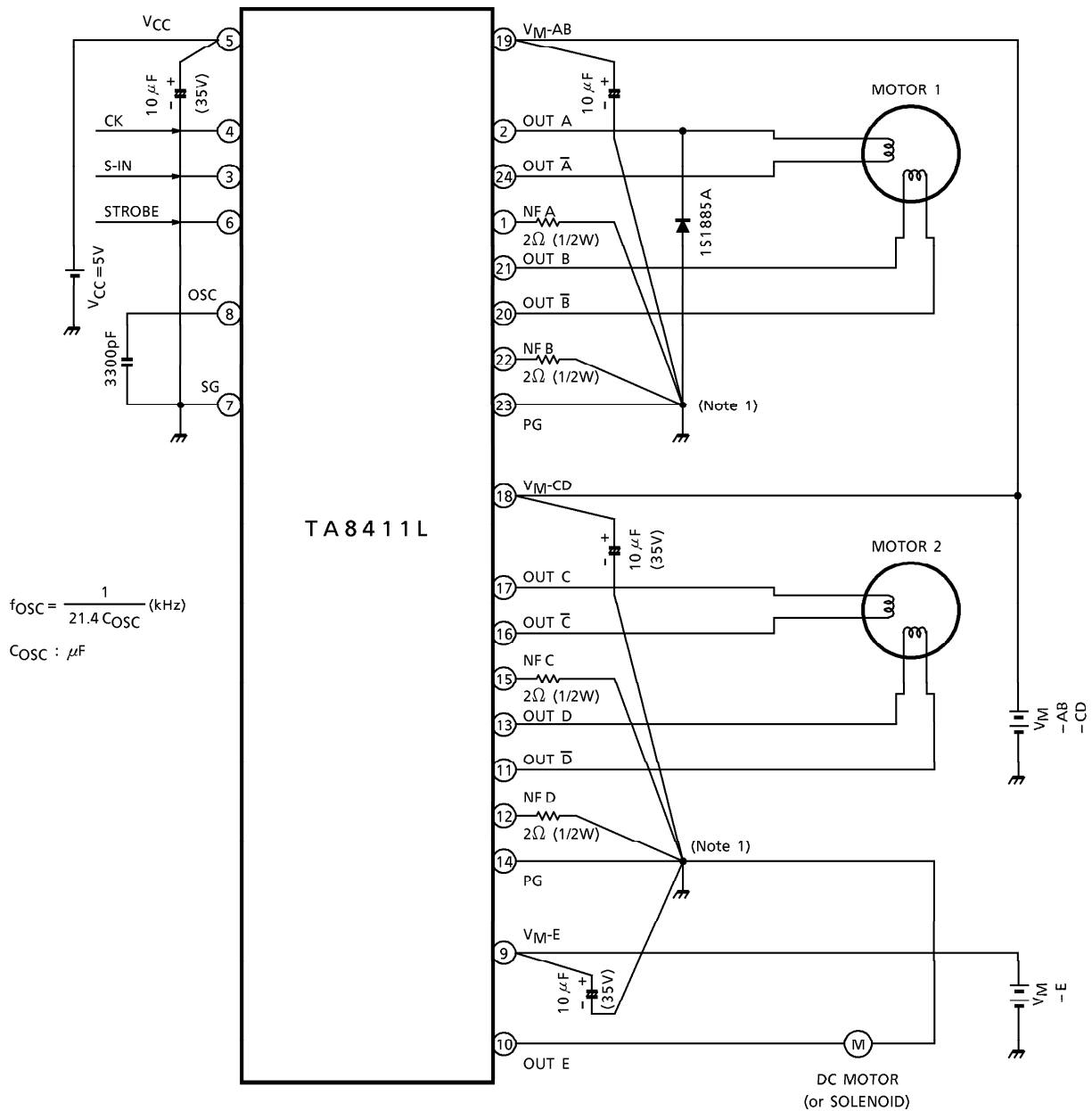

- (Note 1) Care should be taken not to have a common impedance with Output Current pass of each Motor (NF A, NF B for Motor 1, NF C, NF D for Motor 2 and PG for DC Motor) and any other signal lines. And recommend to take One Point GND with each Output Current pass and corresponding PG terminal. (See Table 1 of Block Diagram.)
- (Note 2) Utmost care is necessary in the design of the output line, V_M and GND line since IC may be destroyed due to short-circuit between outputs, air contamination fault, or fault by improper grounding.

OUTLINE DRAWING
HDIP24-P500-2.00

Unit : mm

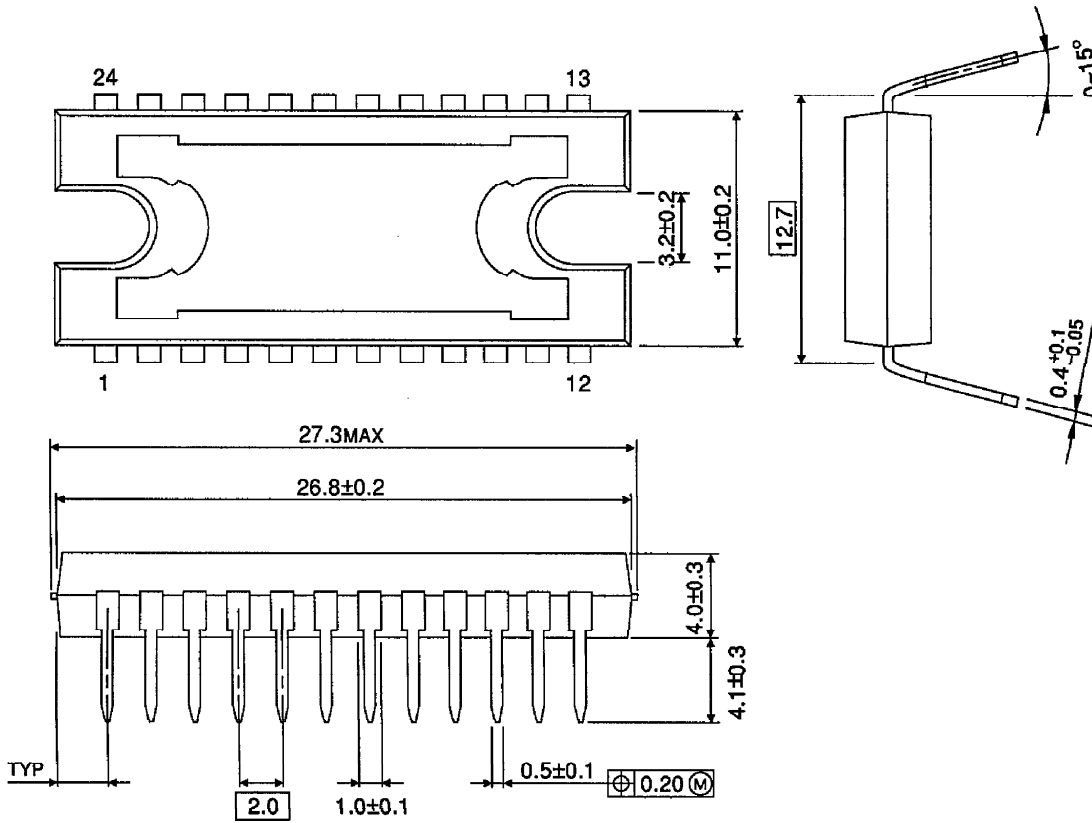

Weight : 4.30g (Typ.)