

TOSHIBA Bipolar Linear Integrated Circuit

TA8492P/PG

Three-Phase Full-Wave Brushless DC Motor Driver IC

The TA8492P/PG is a three-phase, full-wave, supply voltage-control motor driver IC.

Features

- Output current: I_O (max) = 1.5 A
- Supply voltage control motor driver
- CW/CCW/STOP function
- Operating voltage range: V_{CC} (opr.) = 7~18 V
 V_S (opr.) = 0~18 V

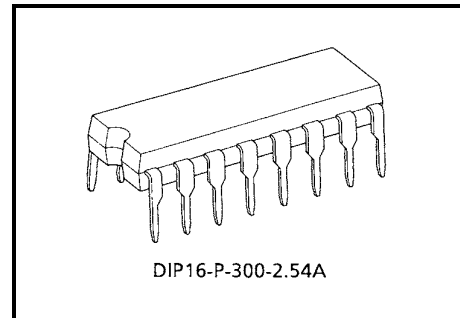

Weight: 1.11 g (typ.)

Block Diagram

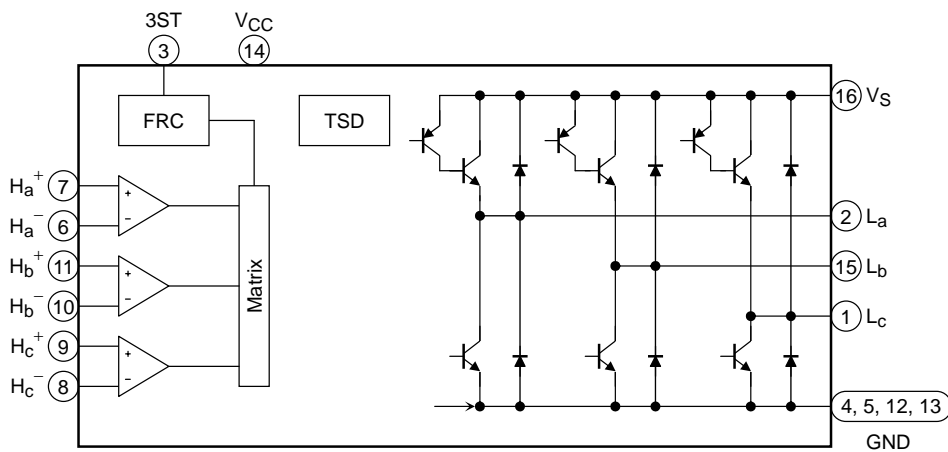

The TA8492PG is a Pb-free product.
The following conditions apply to solderability:

*Solderability

1. Use of Sn-37Pb solder bath
*solder bath temperature = 230°C
*dipping time = 5 seconds
*number of times = once
*use of R-type flux
2. Use of Sn-3.0Ag-0.5Cu solder bath
*solder bath temperature = 245°C
*dipping time = 5 seconds
* number of times = once
*use of R-type flux

Pin Description

| Pin No. | Symbol | Function |
|---------|-----------------------------|---|
| 1 | L _c | c-phase drive output pin |
| 2 | L _a | a-phase drive output pin |
| 3 | 3ST | Switching CW/CCW/Stop |
| 4 | GND | — |
| 5 | GND | — |
| 6 | H _a ⁻ | a-phase negative hall signal input pin |
| 7 | H _a ⁺ | a-phase positive hall signal input pin |
| 8 | H _c ⁻ | c-phase negative hall signal input pin |
| 9 | H _c ⁺ | c-phase positive hall signal input pin |
| 10 | H _b ⁻ | b-phase negative hall signal input pin |
| 11 | H _b ⁺ | b-phase positive hall signal input pin |
| 12 | GND | — |
| 13 | GND | — |
| 14 | V _{CC} | Supply voltage pin for control circuits |
| 15 | L _b | b-phase drive output pin |
| 16 | V _S | Supply voltage pin for output circuit |

Functions

| FRS | Hall Input | | | Output | | |
|---------|----------------|----------------|----------------|----------------|----------------|----------------|
| | H _a | H _b | H _c | L _a | L _b | L _c |
| Forward | 1 | 0 | 1 | L | H | M |
| | 1 | 0 | 0 | L | M | H |
| | 1 | 1 | 0 | M | L | H |
| | 0 | 1 | 0 | H | L | M |
| | 0 | 1 | 1 | H | M | L |
| | 0 | 0 | 1 | M | H | L |
| Reverse | 1 | 0 | 1 | H | L | M |
| | 1 | 0 | 0 | H | M | L |
| | 1 | 1 | 0 | M | H | L |
| | 0 | 1 | 0 | L | H | M |
| | 0 | 1 | 1 | L | M | H |
| | 0 | 0 | 1 | M | L | H |
| Stop | 1 | 0 | 1 | High Impedance | | |
| | 1 | 0 | 0 | | | |
| | 1 | 1 | 0 | | | |
| | 0 | 1 | 0 | | | |
| | 0 | 1 | 1 | | | |
| | 0 | 0 | 1 | | | |

Absolute Maximum Ratings (Ta = 25°C)

| Characteristic | Symbol | Rating | Unit |
|-----------------------|------------------|--------------|------|
| Supply voltage | V _S | 20 | V |
| | V _{CC} | 20 | V |
| Output current | I _O | 1.5 | A |
| Power dissipation | P _D | 1.4 (Note 1) | W |
| | | 2.7 (Note 2) | |
| Operating temperature | T _{opr} | -30~85 | °C |
| Storage temperature | T _{stg} | -55~150 | °C |

Note 1: Not mounted on the PCB

Note 2: Mounted on a PCB (PCB area, 50 × 50 × 0.8 mm; cu area, over 60%)

Electrical Characteristics (Ta = 25°C, V_{CC} = V_S = 12 V)

| Characteristic | | Symbol | Test Circuit | Test Condition | Min | Typ. | Max | Unit |
|--|---------------------------------|----------------------|--------------|---|-----------------------|------|-----------------------|-------------------|
| Supply current | | I _{CC-1} | 1 | V _{CC} = 12 V, 3ST: GND, V _S : Open | — | 5.0 | 7.0 | mA |
| | | I _{CC-2} | | V _{CC} = 18 V, 3ST: GND, V _S : Open | — | 6.0 | 9.0 | |
| | | I _{CC-3} | | Stop (3ST = V _{CC}) | — | 2.5 | 4 | |
| Output saturation voltage | Upper | V _{SAT (U)} | 2 | I _O = 1 A (source current) | — | 1.35 | 1.7 | V |
| | Lower | V _{SAT (L)} | 3 | I _O = 1 A (sink current) | — | 0.4 | 0.6 | |
| Output leak current | Upper | I _{L (U)} | 4 | V _S = 20 V | — | — | 50 | μA |
| | Lower | I _{L (L)} | 5 | V _S = 20 V | — | — | 50 | |
| Hall amp. | Input sensitivity | V _H | 6 | — | 20 | — | 400 | mV _{p-p} |
| | Common-mode input voltage range | V _{CMRH} | 7 | — | 2 | — | V _{CC} - 3.5 | V |
| CW/CCW control operation voltage | Stop | V _{STP} | 6 | — | V _{CC} - 0.4 | — | V _{CC} | V |
| | CW | V _{FW} | | — | 2.5 | — | 6.5 | |
| | CCW | V _{RV} | | — | 0 | — | 0.4 | |
| Thermal shutdown operating temperature | | T _{SD} | — | — | — | 160 | — | °C |

Functional Description

- Hall amp. circuit

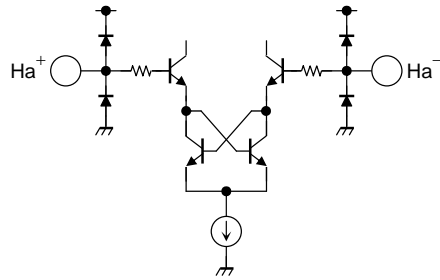

The Hall amp is a high-gain amp. The input sensitivity is 20 mV_{p-p} (min). Make sure that the input amplitude does not exceed 400 mV_{p-p}.

The common-mode voltage V_{CMRH} 2.0 to $V_{CC} - 3.5$ V.

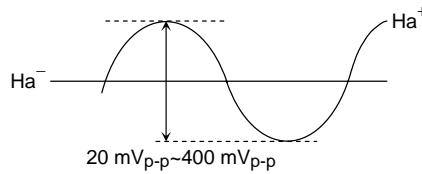

- CW/CCW/Stop control circuit

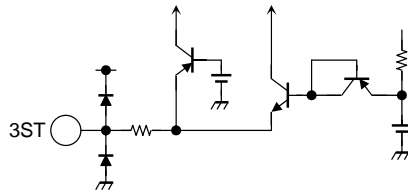

In Reverse mode, the control input (3ST) voltage range is $V_{RV} = 0$ to 0.4 V. However, keep the voltage as close to the IC GND as possible (see the application circuit diagram).

Similarly, in Stop mode, keep the voltage as close to the IC V_{CC} as possible.

In Forward mode, Toshiba recommends that the input voltage be $V_{CC}/2$.

- Output circuit

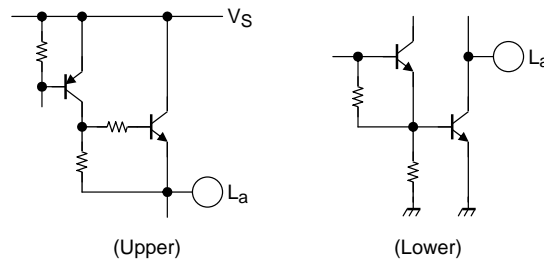

The output circuit uses voltage control where the upper and lower output transistors are saturated and the output current is controlled by the V_S voltage. To reduce switching noise, connect a snubber capacitor to the output circuit.

- Thermal shutdown circuit

The circuit turns off output when $T_j = 160^\circ\text{C}$ (typ.) (according to design specification)

Handling Precautions

CW/CCW/Stop control circuit

- a) At 3ST input, because the input voltage ranges for VRV (Reverse mode) and VSTP (Stop mode) are narrow, make sure no impedance is caused between the IC VCC and GND pins. Do not connect an input resistor to the 3ST pin as this will cause voltage offset.
- b) When controlling the rotation direction using 3ST input, switch the direction from Reverse to Stop mode or vice versa with $V_S = 0$ V; otherwise punch-through current may be generated at output.

Hall amp. circuit

A Hall IC input amplitude of over 400 mV_{p-p} causes an output function error. Make sure the amplitude is within the specified range.

Output circuit

Particular care is necessary in the design of the output, V_S , VCC and GND lines since the IC may be destroyed due to short circuits between output air contamination faults, or faults caused by improper grounding

External Parts

| Symbol | Function | Recommended Value | Remarks |
|----------------|--|-------------------|----------|
| C ₁ | Power supply line oscillation prevention | 4.7 μF | — |
| C ₂ | Power supply line oscillation prevention | 4.7 μF | — |
| C ₃ | Output noise reduction | 4.7 μF | (Note 3) |
| R ₁ | Hall bias | — | (Note 4) |

Note 3: Set an appropriate value depending on the motor and use conditions.
Set an appropriate value so that the Hall IC output common-mode input voltage and amplitude fall within the specified ranges in the Electrical Characteristics table.

Note 4: Be sure to set this bias so that the Hall element output amplitude and common-mode input voltage fall within the ranges specified in the table of electrical characteristics.

Test circuit

1. ICC1, ICC2, ICC3

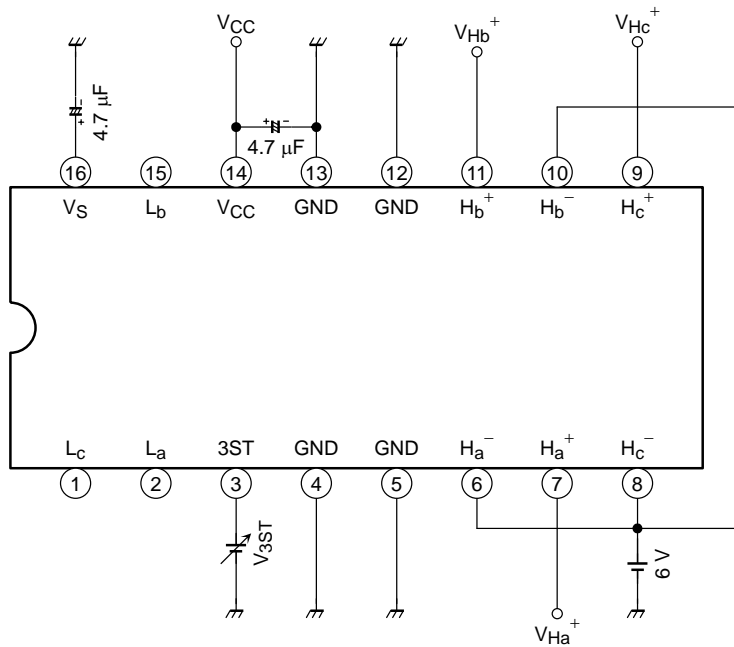

- ICC1: Input V_{Ha}^+ , V_{Hb}^+ , V_{Hc}^+ (6.01 V/5.99 V). $V_{CC} = 12\text{ V}/V_{3ST} = \text{GND}$
- ICC2: Input V_{Ha}^+ , V_{Hb}^+ , V_{Hc}^+ (6.01 V/5.99 V). $V_{CC} = 18\text{ V}/V_{3ST} = \text{GND}$
- ICC3: Input V_{Ha}^+ , V_{Hb}^+ , V_{Hc}^+ (6.01 V/5.99 V). $V_{CC} = 12\text{ V}/V_{3ST} = V_{CC}$

2. VSAT (U)

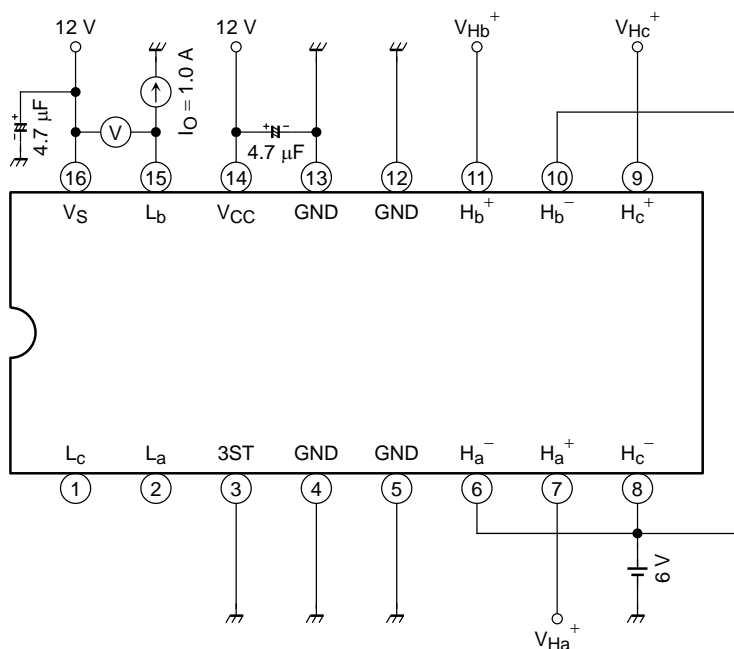

- VSAT (U): Input V_{Ha}^+ , V_{Hb}^+ , V_{Hc}^+ (6.01 V/5.99 V), check that the output function is at High level, then measure phases a, b, and c.

3. VSAT (L)

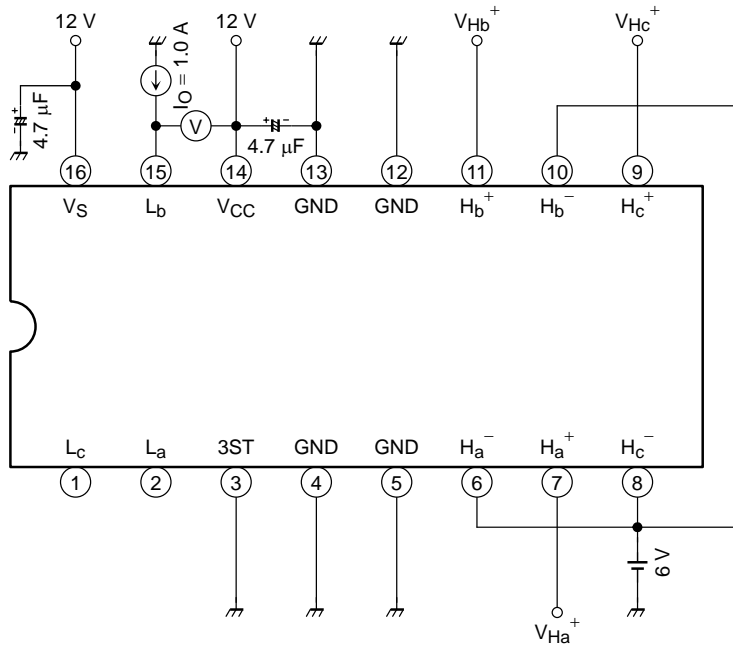

- VSAT (L): Input V_{Ha}^+ , V_{Hb}^+ , V_{Hc}^+ (6.01 V/5.99 V) and check that the output function is "L". (a-phase, b-phase, c-phase)

4. IL (U)

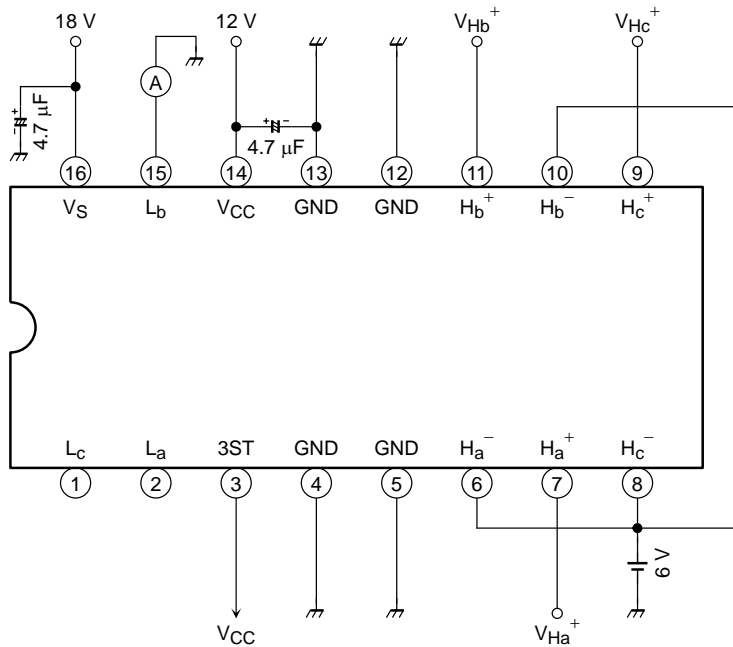

- IL (U): Check that the output function is high impedance at 3ST = VCC. (a-phase, b-phase, c-phase)

5. $I_L(L)$

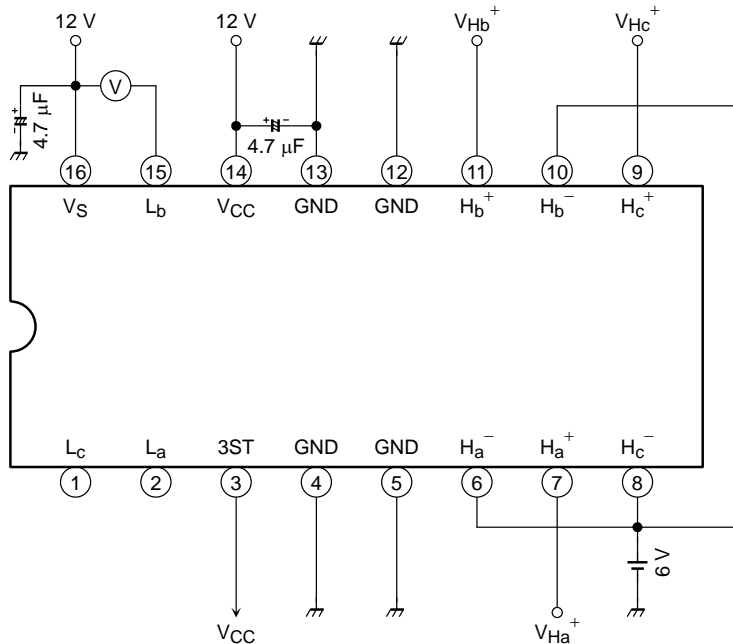

- $I_L(L)$: Check that the output function is high impedance at $3ST = VCC$.
(a-phase, b-phase, c-phase)

6. $V_H, V_{STP}, V_{FW}, V_{RV}$

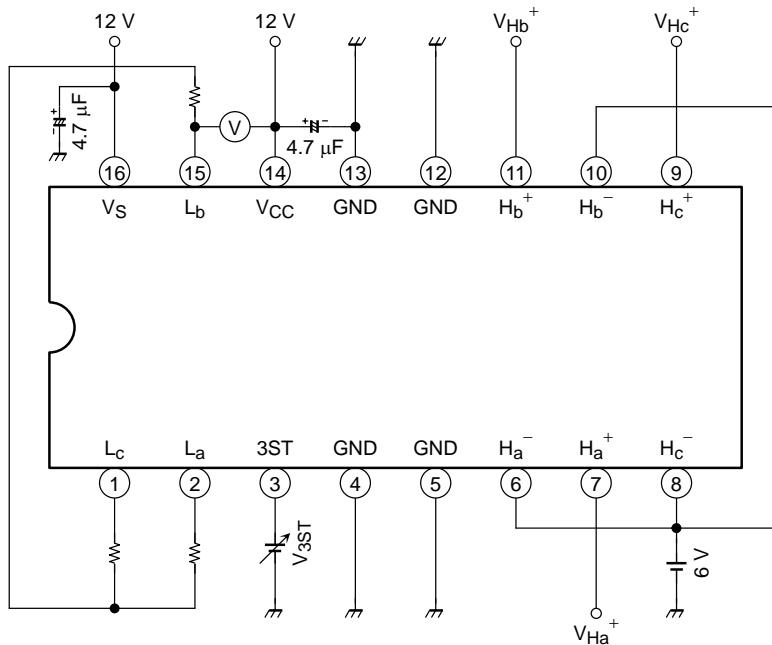

- V_H : Input $V_{Ha}^+, V_{Hb}^+, V_{Hc}^+$ (6.01 V/5.99 V) and check the output function.
(a-phase, b-phase, c-phase) AT $V_{3ST} = GND$.
- V_{STP} : When V_{3ST} is 8.5 V, input $V_{Ha}^+, V_{Hb}^+, V_{Hc}^+$ (6.01 V/5.99 V), fix the output function, then check that the output function is at high impedance.
- V_{FW} : Input $V_{Ha}^+, V_{Hb}^+, V_{Hc}^+$ (6.01 V/5.99 V) and check that the output function is forward mode.
AT $V_{3ST} = 2.5 V/6.5 V$.

- V_{RV}: Input V_{Ha}⁺, V_{Hb}⁺, V_{Hc}⁺ (6.01 V/5.99 V) and check that the output function is reverse mode.
AT V_{3ST} = 0.4 V.

7. V_{CMRH}

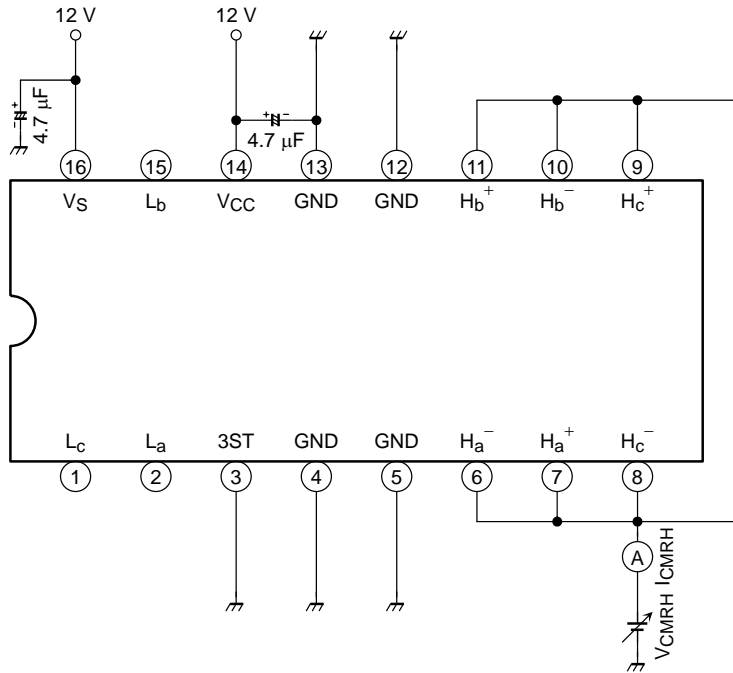

- V_{CMRH}: Measure the I_{CMRH} gap between V_{CMRH} = 2 V and 8.5 V.

Application Circuit

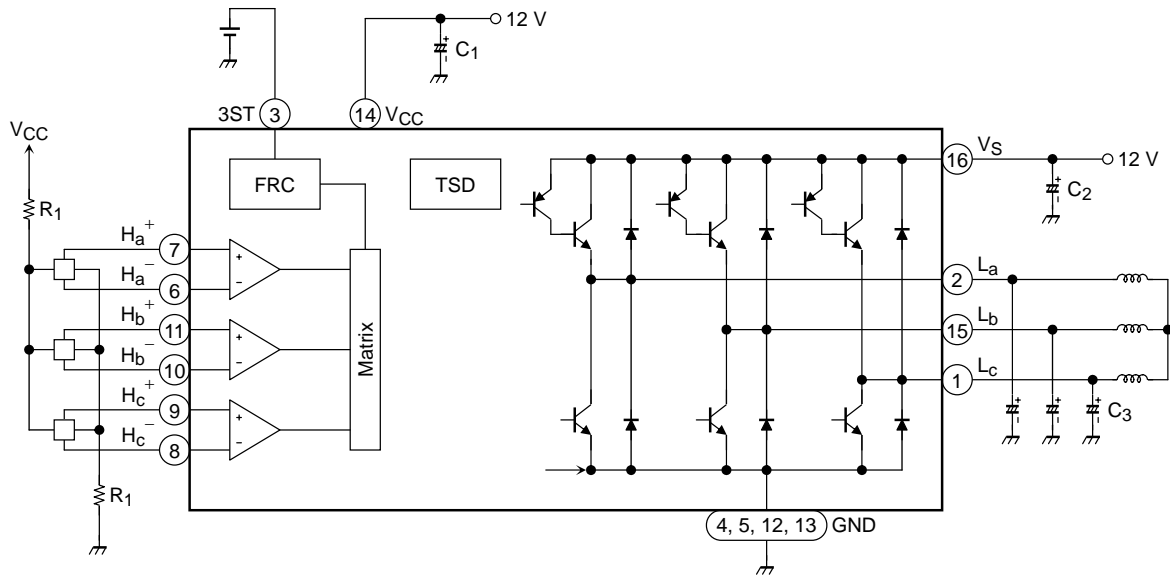

Note: Utmost care is necessary in the design of the output, V_{CC} , V_M , and GND lines since the IC may be destroyed by short-circuiting between outputs, air contamination faults, or faults due to improper grounding, or by short-circuiting between contiguous pins.

Package Dimensions

DIP16-P-300-2.54A

Unit : mm

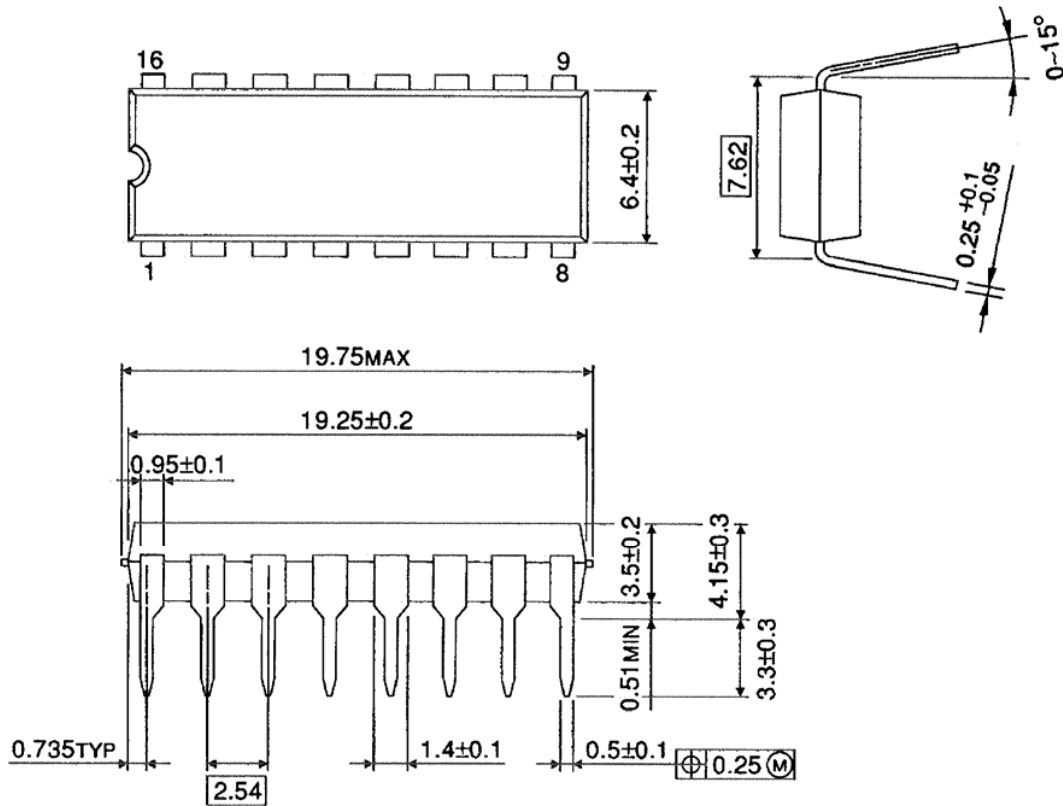

Weight: 1.11 g (typ.)

Notes on Contents**1. Block Diagrams**

Some of the functional blocks, circuits, or constants in the block diagram may be omitted or simplified for explanatory purposes.

2. Equivalent Circuits

The equivalent circuit diagrams may be simplified or some parts of them may be omitted for explanatory purposes.

3. Timing Charts

Timing charts may be simplified for explanatory purposes.

4. Application Circuits

The application circuits shown in this document are provided for reference purposes only. Thorough evaluation is required, especially at the mass production design stage.

Toshiba does not grant any license to any industrial property rights by providing these examples of application circuits.

5. Test Circuits

Components in the test circuits are used only to obtain and confirm the device characteristics. These components and circuits are not guaranteed to prevent malfunction or failure from occurring in the application equipment.

IC Usage Considerations**Notes on handling of ICs**

- [1] The absolute maximum ratings of a semiconductor device are a set of ratings that must not be exceeded, even for a moment. Do not exceed any of these ratings.
Exceeding the rating(s) may cause the device breakdown, damage or deterioration, and may result injury by explosion or combustion.
- [2] Use an appropriate power supply fuse to ensure that a large current does not continuously flow in case of over current and/or IC failure. The IC will fully break down when used under conditions that exceed its absolute maximum ratings, when the wiring is routed improperly or when an abnormal pulse noise occurs from the wiring or load, causing a large current to continuously flow and the breakdown can lead smoke or ignition. To minimize the effects of the flow of a large current in case of breakdown, appropriate settings, such as fuse capacity, fusing time and insertion circuit location, are required.
- [3] If your design includes an inductive load such as a motor coil, incorporate a protection circuit into the design to prevent device malfunction or breakdown caused by the current resulting from the inrush current at power ON or the negative current resulting from the back electromotive force at power OFF. IC breakdown may cause injury, smoke or ignition.
Use a stable power supply with ICs with built-in protection functions. If the power supply is unstable, the protection function may not operate, causing IC breakdown. IC breakdown may cause injury, smoke or ignition.
- [4] Do not insert devices in the wrong orientation or incorrectly.
Make sure that the positive and negative terminals of power supplies are connected properly. Otherwise, the current or power consumption may exceed the absolute maximum rating, and exceeding the rating(s) may cause the device breakdown, damage or deterioration, and may result injury by explosion or combustion.
In addition, do not use any device that is applied the current with inserting in the wrong orientation or incorrectly even just one time.

Points to remember on handling of ICs**(1) Thermal Shutdown Circuit**

Thermal shutdown circuits do not necessarily protect ICs under all circumstances. If the thermal shutdown circuits operate against the over temperature, clear the heat generation status immediately.

Depending on the method of use and usage conditions, such as exceeding absolute maximum ratings can cause the thermal shutdown circuit to not operate properly or IC breakdown before operation.

(2) Heat Radiation Design

In using an IC with large current flow such as power amp, regulator or driver, please design the device so that heat is appropriately radiated, not to exceed the specified junction temperature (T_j) at any time and condition. These ICs generate heat even during normal use. An inadequate IC heat radiation design can lead to decrease in IC life, deterioration of IC characteristics or IC breakdown. In addition, please design the device taking into consideration the effect of IC heat radiation with peripheral components.

(3) Back-EMF

When a motor rotates in the reverse direction, stops or slows down abruptly, a current flow back to the motor's power supply due to the effect of back-EMF. If the current sink capability of the power supply is small, the device's motor power supply and output pins might be exposed to conditions beyond maximum ratings. To avoid this problem, take the effect of back-EMF into consideration in system design.

RESTRICTIONS ON PRODUCT USE

060116EBA

- The information contained herein is subject to change without notice. 021023_D
- TOSHIBA is continually working to improve the quality and reliability of its products. Nevertheless, semiconductor devices in general can malfunction or fail due to their inherent electrical sensitivity and vulnerability to physical stress. It is the responsibility of the buyer, when utilizing TOSHIBA products, to comply with the standards of safety in making a safe design for the entire system, and to avoid situations in which a malfunction or failure of such TOSHIBA products could cause loss of human life, bodily injury or damage to property.
In developing your designs, please ensure that TOSHIBA products are used within specified operating ranges as set forth in the most recent TOSHIBA products specifications. Also, please keep in mind the precautions and conditions set forth in the "Handling Guide for Semiconductor Devices," or "TOSHIBA Semiconductor Reliability Handbook" etc. 021023_A
- The TOSHIBA products listed in this document are intended for usage in general electronics applications (computer, personal equipment, office equipment, measuring equipment, industrial robotics, domestic appliances, etc.). These TOSHIBA products are neither intended nor warranted for usage in equipment that requires extraordinarily high quality and/or reliability or a malfunction or failure of which may cause loss of human life or bodily injury ("Unintended Usage"). Unintended Usage include atomic energy control instruments, airplane or spaceship instruments, transportation instruments, traffic signal instruments, combustion control instruments, medical instruments, all types of safety devices, etc. Unintended Usage of TOSHIBA products listed in this document shall be made at the customer's own risk. 021023_B
- The products described in this document shall not be used or embedded to any downstream products of which manufacture, use and/or sale are prohibited under any applicable laws and regulations. 060106_Q
- The information contained herein is presented only as a guide for the applications of our products. No responsibility is assumed by TOSHIBA for any infringements of patents or other rights of the third parties which may result from its use. No license is granted by implication or otherwise under any patent or patent rights of TOSHIBA or others. 021023_C
- The products described in this document are subject to the foreign exchange and foreign trade laws. 021023_E