

TOSHIBA BIPOLAR LINEAR INTEGRATED CIRCUIT SILICON MONOLITHIC

TA8423P, TA8423F

3 PHASE Bi-DIRECTIONAL HALL MOTOR DRIVER

The TA8423P, TA8423F are 3 phase Bi-Directional Hall Motor Driver IC designed for VCR (Capstan, head and reel), ADP, Tape Deck, FDD and other Output Driver for 3 phase bipolar Hall motors.

FEATURES

- Few external parts required
- Wide operating supply voltage range
: $V_{CC(opr)} = 7 \sim 17V$
- Forward rotation, reverse rotation and stop are controlled by 1 terminal signal control and easy to interface with CPU.
- High sensitivity of the position sensing circuit.
(Hall sensor input) : $V_H = 20mV_{p-p}$ (Typ.)
- Large output current : $I_O (MAX.) = 1.2A$
- Protect diodes equipped for all inputs
- Recommend to use TOSHIBA Ga-As Hall sensor "THS100 series"
- Built-in internal reference
- Built-in thermal shut down circuit

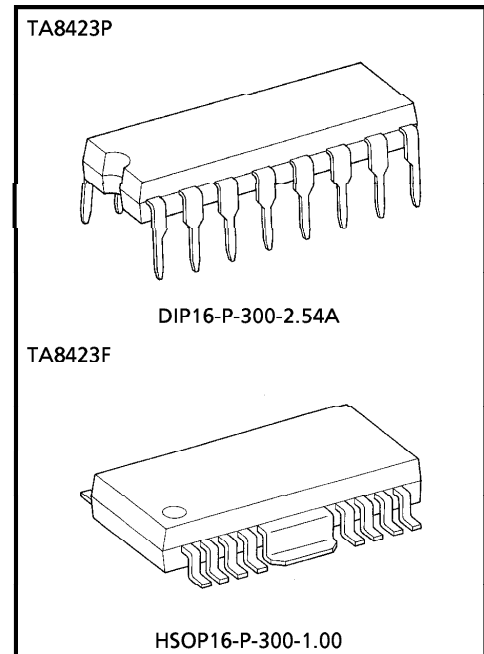

Weight
 DIP16-P-300-2.54A : 1.11g (Typ.)
 HSOP16-P-300-1.00 : 0.50g (Typ.)

961001EBA1

- TOSHIBA is continually working to improve the quality and the reliability of its products. Nevertheless, semiconductor devices in general can malfunction or fail due to their inherent electrical sensitivity and vulnerability to physical stress. It is the responsibility of the buyer, when utilizing TOSHIBA products, to observe standards of safety, and to avoid situations in which a malfunction or failure of a TOSHIBA product could cause loss of human life, bodily injury or damage to property. In developing your designs, please ensure that TOSHIBA products are used within specified operating ranges as set forth in the most recent products specifications. Also, please keep in mind the precautions and conditions set forth in the TOSHIBA Semiconductor Reliability Handbook.
- The products described in this document are subject to foreign exchange and foreign trade control laws.
- The information contained herein is presented only as a guide for the applications of our products. No responsibility is assumed by TOSHIBA CORPORATION for any infringements of intellectual property or other rights of the third parties which may result from its use. No license is granted by implication or otherwise under any intellectual property or other rights of TOSHIBA CORPORATION or others.
- The information contained herein is subject to change without notice.

BLOCK DIAGRAM

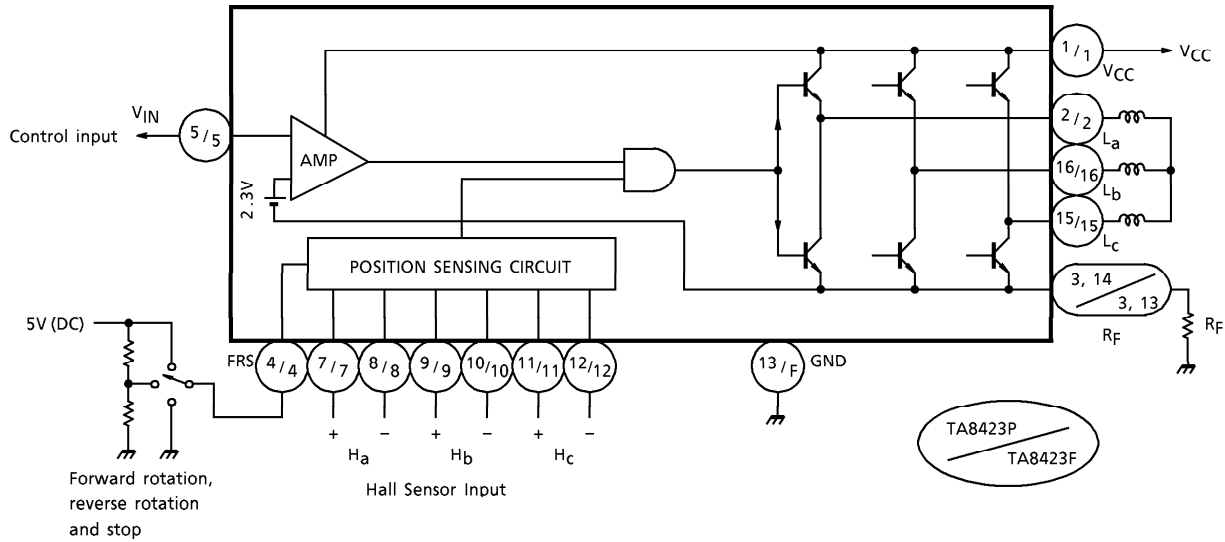

PIN FUNCTION

PIN No.		SYMBOL	FUNCTIONAL DESCRIPTION
P	F		
1	1	V_{CC}	Power supply input terminal.
2	2	L_a	a-phase drive output terminal.
3	3	R_F	Output current detection terminal.
4	4	FRS	Forward / Reverse control terminal.
5	5	V_{IN}	Control Amp. positive input terminal.
6	6	N.C	Non Connection.
7	7	H_a+	a-phase Hall Amp. positive input terminal.
8	8	H_a-	a-phase Hall Amp. negative input terminal.
9	9	H_b+	b-phase Hall Amp. positive input terminal.
10	10	H_b-	b-phase Hall Amp. negative input terminal.
11	11	H_c+	c-phase Hall Amp. positive input terminal.
12	12	H_c-	c-phase Hall Amp. negative input terminal.
13	FIN	GND	GND terminal.
14	13	R_F	Output current detection terminal.
15	15	L_c	c-phase drive output terminal.
16	16	L_b	b-phase drive output terminal.

1. Control input circuit

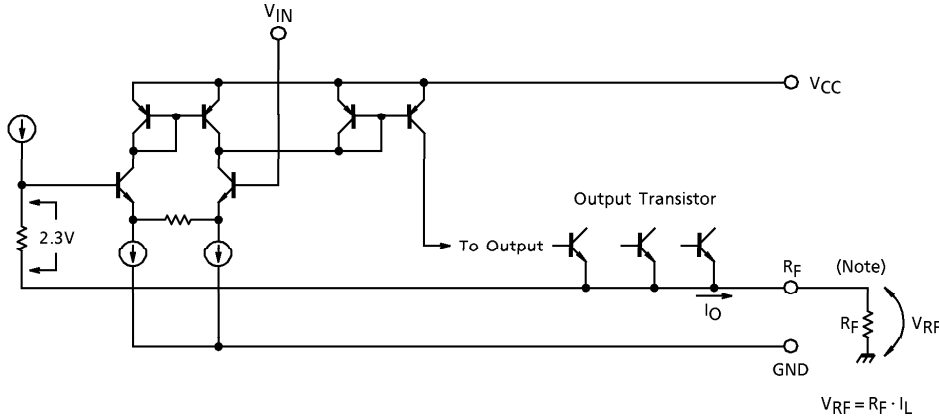

$V_{RF} (= R_F \cdot I_L)$ of feed back voltage is feed backed to negative input of control amp internally. Voltage gain becomes approximately equal to 1 (0dB) by this internal feed back.

(Note) 2 terminals (Pin③, ⑬ for F version and Pin③, ⑭ for P version) are provided for RF terminal to decrease the interference caused by internal common impedance. Both Pins are required to connect for stable operation.

INPUT-OUTPUT CHARACTERISTIC

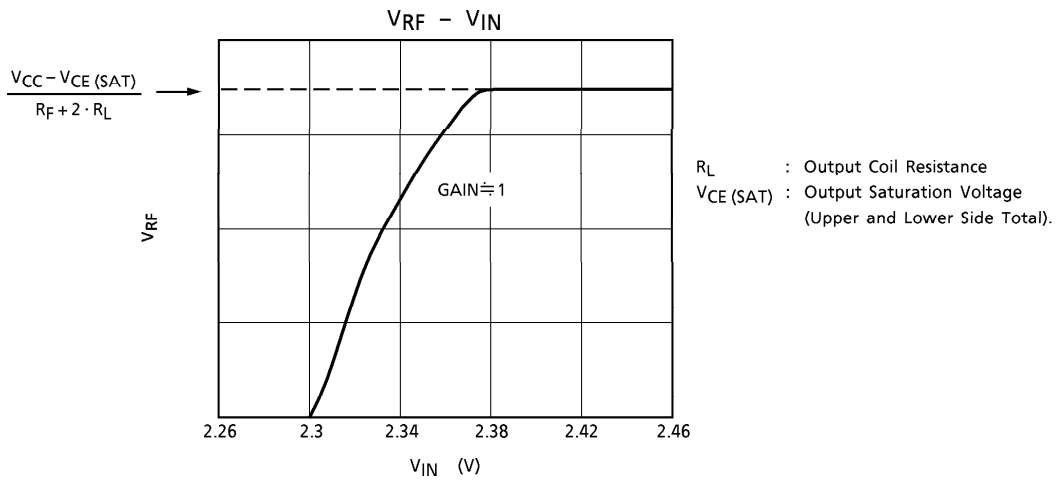

V_{RF} is feed back voltage generated by R_F and output current of I_L , drive current of I_D and internal reference circuit current of I_R .

But I_O and I_R are negligible therefore,

$$I_R \ll I_L + I_D$$

$$V_{RF} \doteq R_F (I_L + I_O + I_R)$$

$$I_L \gg I_D, I_R$$

$$V_{RF} \doteq R_F \cdot I_L$$

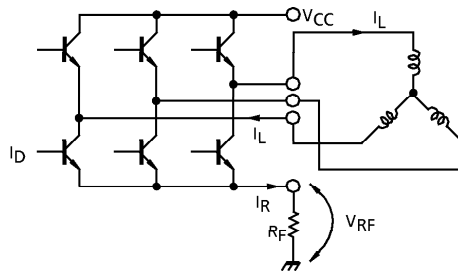

0 Torque state is obtained when less than 2.3V of control voltage fed into input terminal.

0 Torque state also obtained by select a stop mode by controlling FRS input (Pin④).

Less supply current is obtained with this condition.

2. FRS CIRCUIT

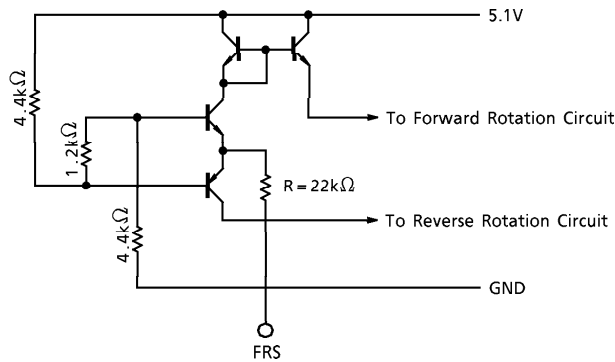

Forward, Reverse and Stop Modes are selectable by controlling this terminal.

Specified voltages are less than 1.3V (Forward), 2.4~3.0V or Open (Stop) and 3.9V~ V_{CC} (Reverse).

$V_{FRS} - I_{FRS}$ characteristic is shown below.

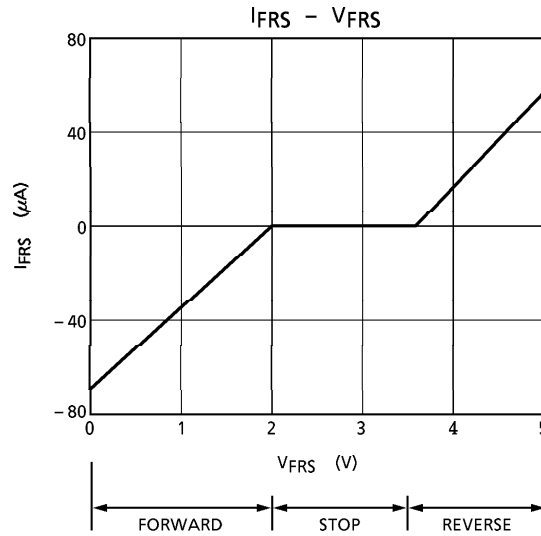

FUNCTION

FRS INPUT	POSITION SENSING INPUT			OUTPUT		
	H _a	H _b	H _c	L _a	L _b	L _c
L ($V_{④} < 1.3V$)	1	0	1	H	L	M
	1	0	0	H	M	L
	1	1	0	M	H	L
	0	1	0	L	H	M
	0	1	1	L	M	H
	0	0	1	M	L	H
H ($3.9V < V_{④} < V_{CC}$)	1	0	1	L	H	M
	1	0	0	L	M	H
	1	1	0	M	L	H
	0	1	0	H	L	M
	0	1	1	H	M	L
	0	0	1	M	H	L
M ($2.4V < V_{④} < 3.0V$ or Open)	1	0	1	High Impedance (Stop)		
	1	0	0			
	1	1	0			
	0	1	0			
	0	1	1			
	0	0	1			

(Note) "1" of the Hall Sensor input means that voltage above +20mV is applied to the positive side of each Hall Sensor from the negative side and "0" means that voltage above +20mV is applied to the negative side from the positive side. In this case, needless to say, DC potential must be within the specified common mode voltage range of Hall Sensor input. Further, "H", "M" and "L" of output mean $V_{CC} - V_{SAT1} = 1/2 V_{CC}$ and V_{SAT2} , respectively.

MAXIMUM RATINGS (Ta = 25°C)

CHARACTERISTIC		SYMBOL	RATING	UNIT
Supply Voltage		V _{CC}	18	V
Output Current		I _O	1.2	A
Hall Sensor Input Voltage		V _H	400	mV _{p-p}
Power Dissipation	TA8423P	P _D	1.2 (Note 1)	W
	TA8423F		0.9 (Note 1)	
			8.3 (Note 2)	
Operating Temperature		T _{opr}	- 30~75	°C
Storage Temperature		T _{stg}	- 55~150	°C

(Note 1) No heat sink
 (Note 2) T_c = 25°C

ELECTRICAL CHARACTERISTICS (V_{CC} = 12V, Ta = 25°C)

CHARACTERISTIC		SYMBOL	TEST CIR-CUIT	TEST CONDITION	MIN.	TYP.	MAX.	UNIT
Supply Current		I _{CC1}	1	FRS open	4	8	19	mA
		I _{CC2}		FRS = 5V	4.5	9	21	
		I _{CC3}		V _{CC} = 18V, FRS = GND	5.5	11	22	
Control Amp.	Reference Voltage	V _{ref}	1	—	2.2	2.3	2.4	V
	Voltage Gain	G _V		—	—	0	—	dB
	Input Current	I _{in}		V _{IN} = 3.5V	—	2.5	10	μA
	Reference Voltage Ripple Rejection Ratio	R _r		—	- 60	—	—	dB
Cut-off Current	Upper Side	I _{OL(U)}	—	V _{CC} = 18V	—	—	50	μA
	Lower Side	I _{OL(L)}		V _{CC} = 18V	—	—	50	
Saturation Voltage	Upper Side	V _{SAT1}	2	I _L = 1A	—	1.5	1.9	V
	Lower Side	V _{SAT2}		I _L = 1A	—	0.8	1.2	
Gain Difference		ΔG _V	1	—	—	—	± 1	%
Residual Output Voltage		V _{OR}	1	—	—	0	10	mV _{p-p}
Position Sensing Input	Input Sensitivity	V _H	—	—	—	20	—	mV
	Common Mode Voltage Range	CMR _H	3	—	2.0	—	V _{CC} - 3	V
	Input Offset Voltage	V _{HO}	—	—	—	0	5	mV
Rotation Control (Input Operation Voltage)	Forward	V _F	1	—	- 0.3	—	1.3	V
	Stop	V _S		—	2.4	—	3.0	
	Reverse	V _R		—	3.9	—	V _{CC}	
Thermal Shut Down Circuit Operating Temperature		TSD	—	—	150	—	—	°C

TEST CIRCUIT 1

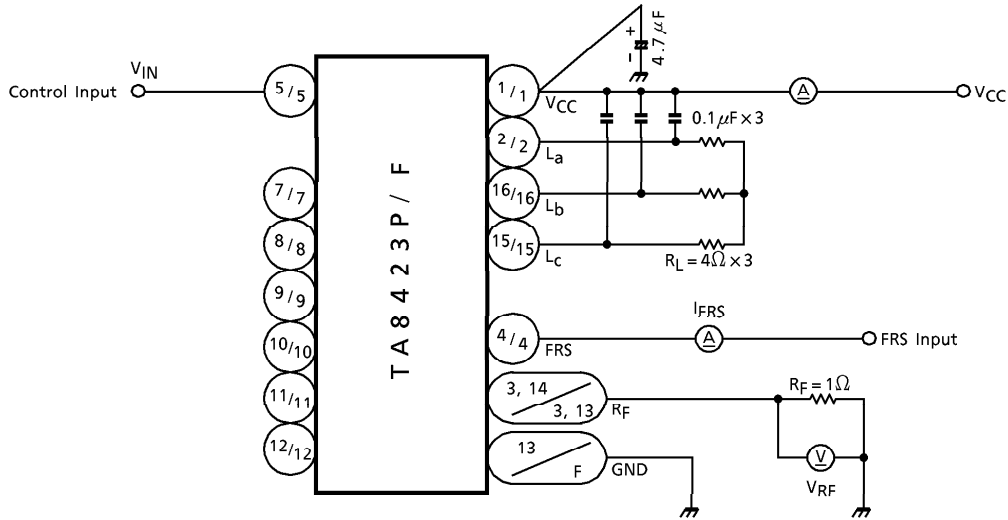

TEST CIRCUIT 2

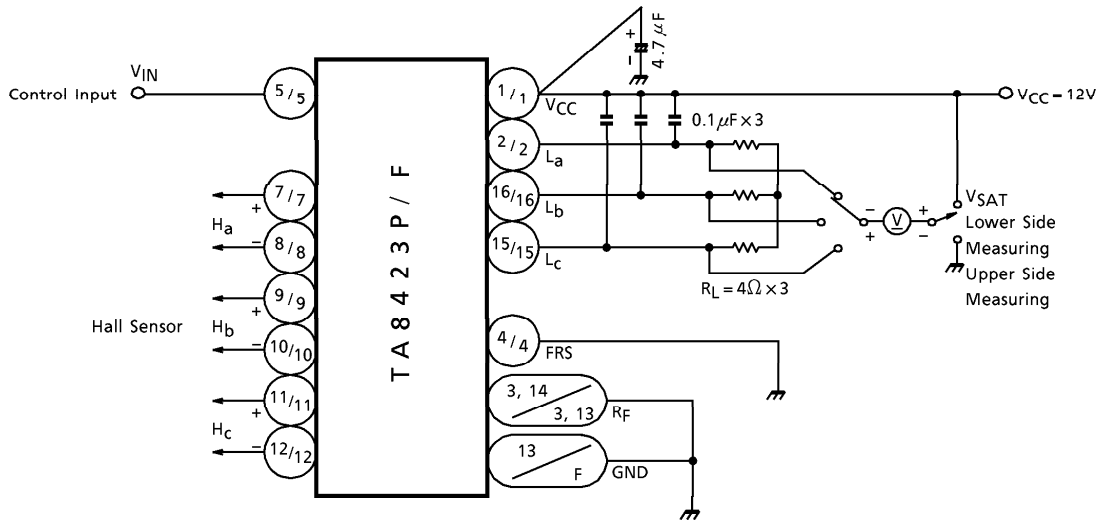

TEST CIRCUIT 3

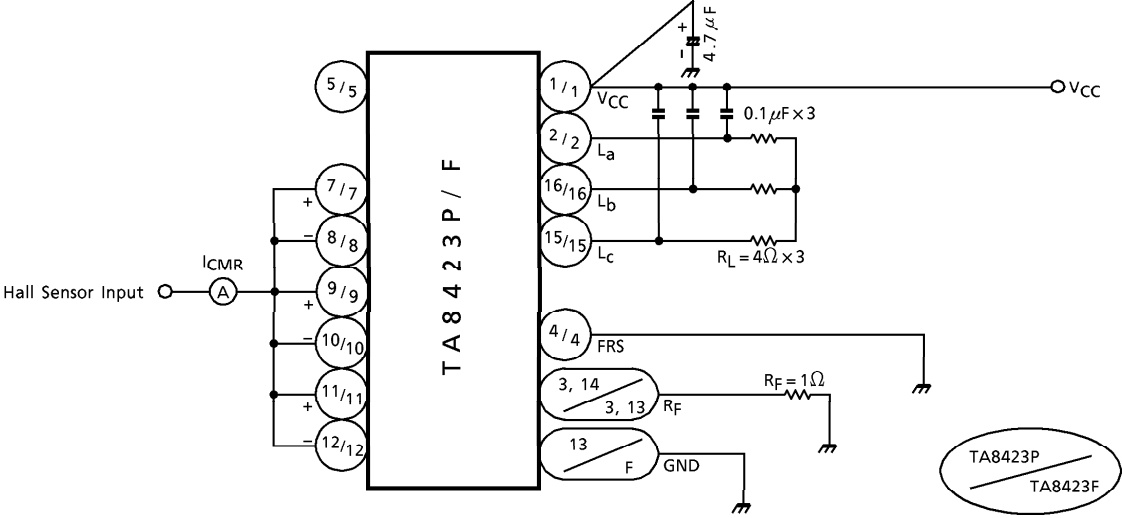

Output Amplifier Saturation Voltage Characteristics

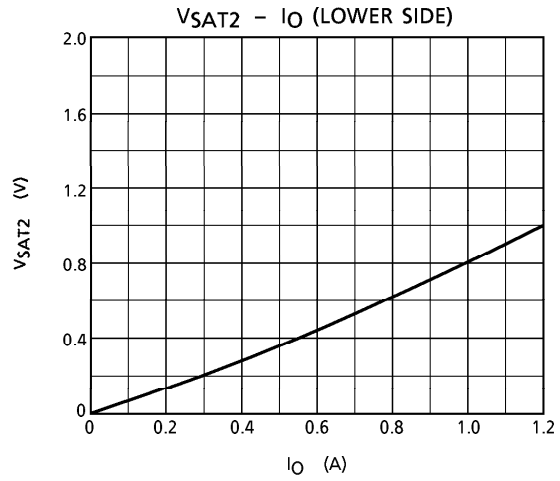
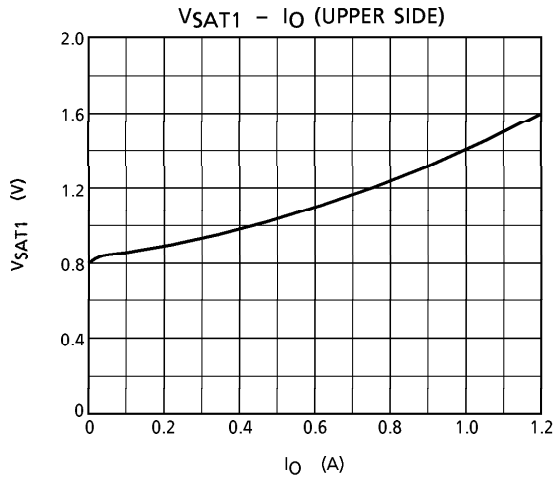

TA8423P

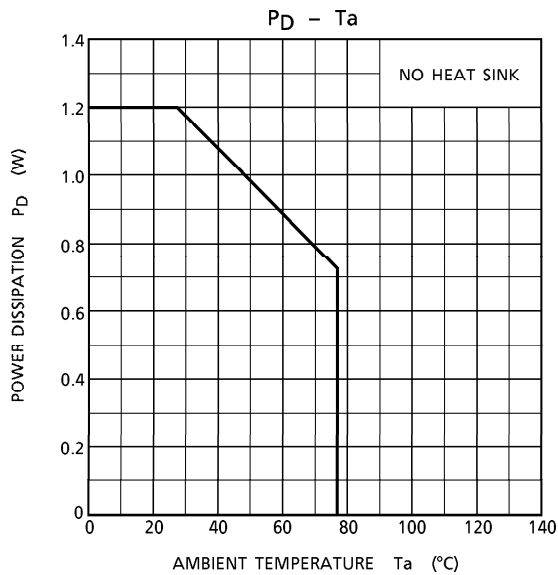

TA8423F

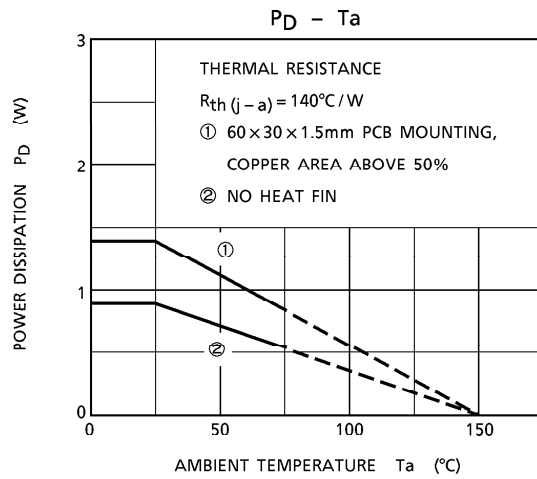

APPLICATION CIRCUIT

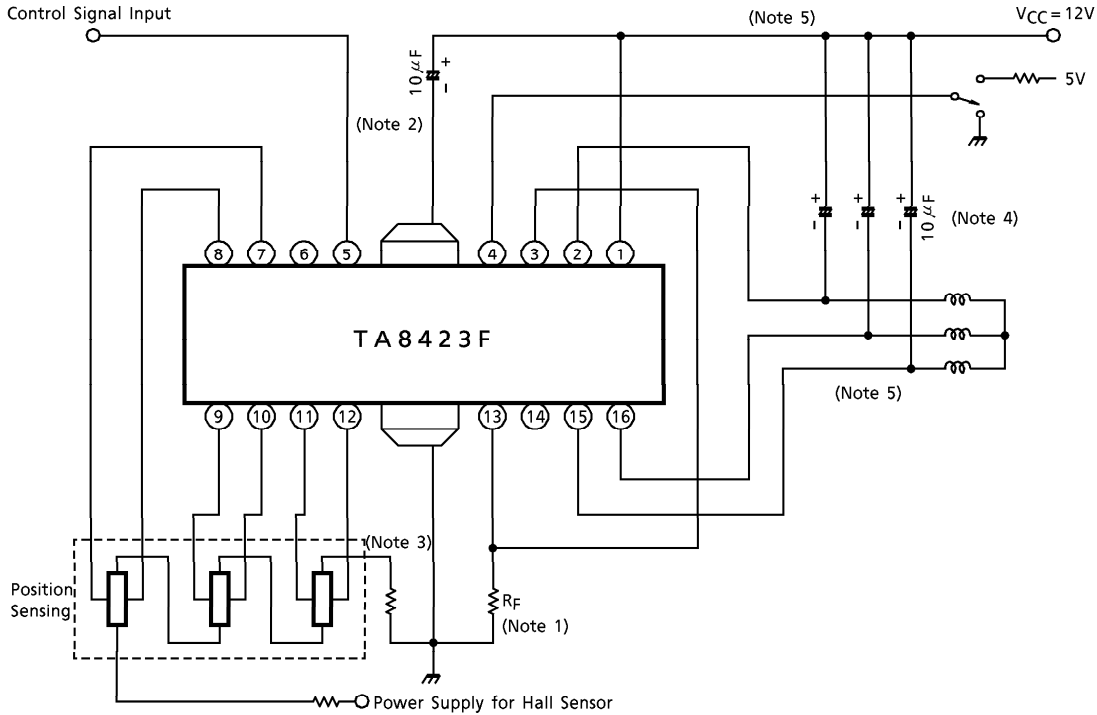

- (Note 1) Recommendable value of R_F is 0.3 to 5Ω . It depends on required initial torque, gain, coil impedance and control voltage of Pin 5.
- (Note 2) To connect directly to IC Pin (Fin for F version and ⑬ Pin for P version) and GND to eliminate the influence of common impedance. It is required to increase the value of this capacitance for stable operations in case of poor wiring or patterning of PCB.
- (Note 3) Special care should be taken not to have a common impedance with GND line, R_F GND line and Hall Sensor GND line.
- (Note 4) Please select to optimum value for eliminate a vibration noise and parasitic oscillation. And also to change the connection (for example, each output to V_{CC} or to R_F) for getting better characteristics.
- (Note 5) Utmost care is necessary in the design of the output line, V_{CC} and GND line since IC may be destroyed due to short-circuit between outputs, air contamination fault, or fault by improper grounding.

OUTLINE DRAWING
DIP16-P-300-2.54A

Unit : mm

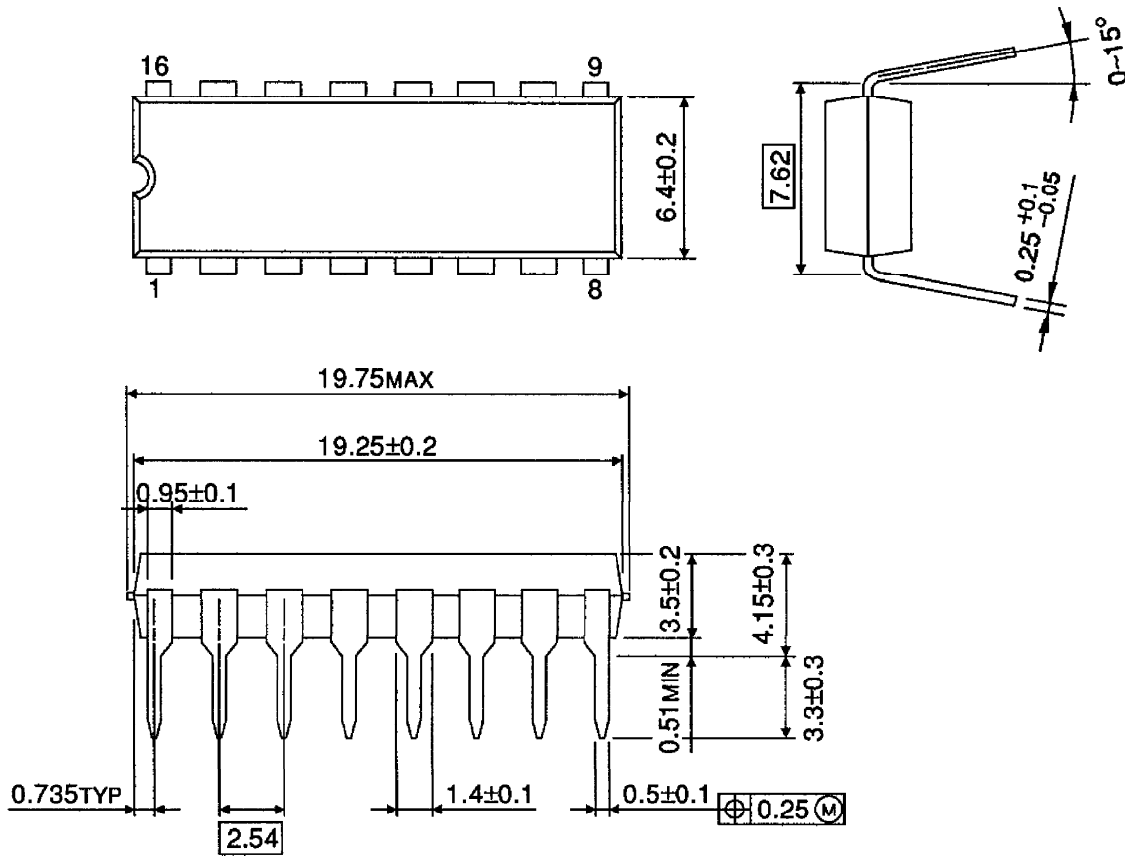

Weight : 1.11g (Typ.)

OUTLINE DRAWING

HSOP16-P-300-1.00

Unit : mm

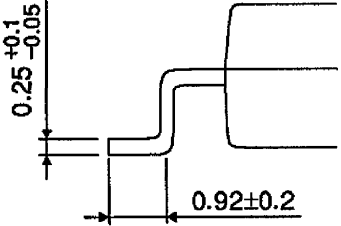
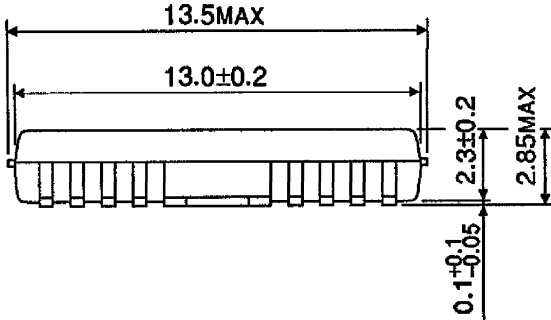
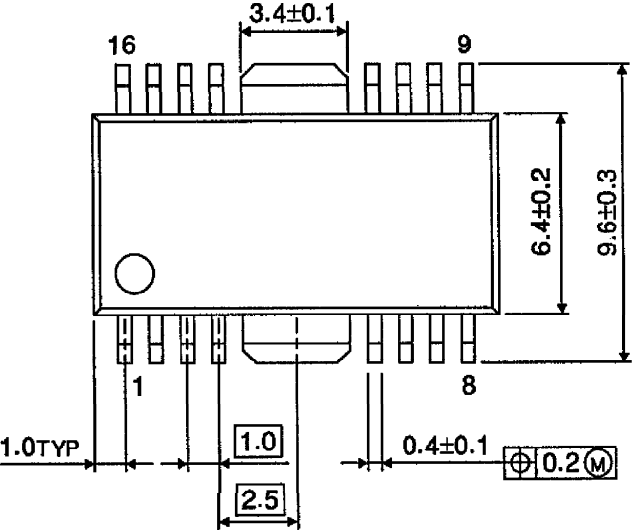

Weight : 0.50g (Typ.)