

TOSHIBA CMOS Integrated Circuit Silicon Monolithic

TB6548F/FG

Three-Phase Full-Wave PWM Sensorless Controller for Brushless DC Motors

The TB6548F/FG is a three-phase full-wave sensorless controller for brushless DC motors. The device supports voltage control by PWM signal input and is capable of PWM type sensorless driving when used in conjunction with the TA84005F/FG.

Features

- Three-phase full-wave sensorless drive
- PWM control (PWM signal is supplied from external sources)
- Turn-on signal output current: 20 mA
- Built-in protection against overcurrent
- Forward/reverse modes
- Built-in lead angle control function (0, 7.5, 15 and 30 degrees)
- Built-in lap turn-on function

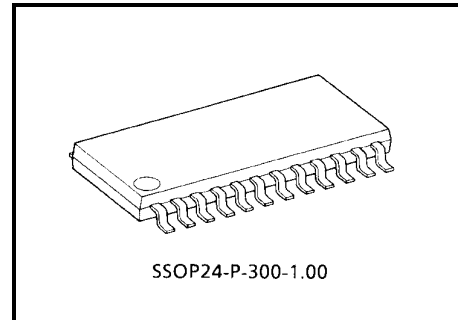

Weight: 0.32 g (typ.)

TB6548FG:

The TB6548FG is a Pb-free product.

The following conditions apply to solderability:

*Solderability

1. Use of Sn-37Pb solder bath
 - *solder bath temperature = 230°C
 - *dipping time = 5 seconds
 - *number of times = once
 - *use of R-type flux
2. Use of Sn-3.0Ag-0.5Cu solder bath
 - *solder bath temperature=245°C
 - *dipping time = 5 seconds
 - *number of times = once
 - *use of R-type flux

Block Diagram

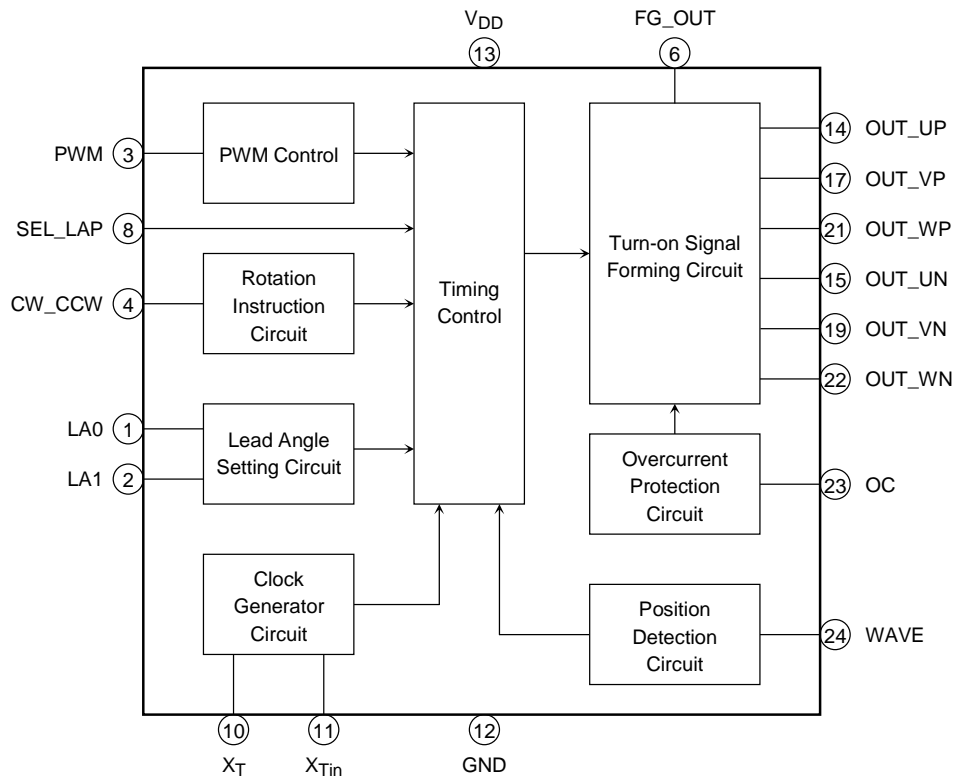

Pin Assignment

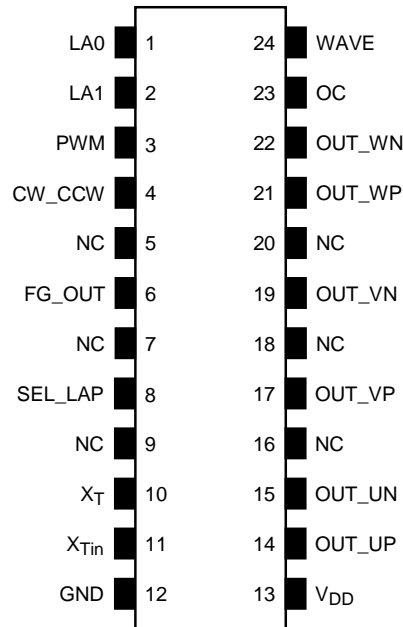

Pin Description

Pin No.	Symbol	I/O	Description
1	LA0	I	Lead angle setting signal input pin <ul style="list-style-type: none"> LA0 = Low, LA1 = Low: Lead angle of 0 degrees LA0 = High, LA1 = Low: Lead angle of 7.5 degrees
2	LA1	I	<ul style="list-style-type: none"> LA0 = Low, LA1 = High: Lead angle of 15 degrees LA0 = High, LA1 = High: Lead angle of 30 degrees Built-in pull-down resistor
3	PWM	I	PWM signal input pin <ul style="list-style-type: none"> Inputs Low-active PWM signal Built-in pull-up resistor Disables input of duty-100% (Low) signal High for 250 ns or longer is required.
4	CW_CCW	I	Rotational direction signal input pin <ul style="list-style-type: none"> High: Reverse (U → W → V) Low, Open: Forward (U → V → W) Built-in pull-down resistor
5	NC	—	Not connected
6	FG_OUT	O	Rotational frequency detection signal output pin <ul style="list-style-type: none"> Equivalent to U-phase signal (except PWM)
7	NC	—	Not connected
8	SEL_LAP	I	Lap turn-on select pin <ul style="list-style-type: none"> Low: Lap turn-on High: 120 degrees turn-on Built-in pull-up resistor
9	NC	—	Not connected
10	X _T	—	Resonator connecting pin
11	X _{Tin}	—	<ul style="list-style-type: none"> Selects starting commutation frequency. Starting commutation frequency $f_{st} = \text{Resonator frequency } f_{xt} / (6 \times 2^{17})$
12	GND	—	Connected to GND.
13	V _{DD}	—	Connected to 5 V power supply.
14	OUT_UP	O	U-phase upper turn-on signal output pin <ul style="list-style-type: none"> U-phase winding wire positive ON/OFF switching pin ON: Low, OFF: High
15	OUT_UN	O	U-phase lower turn-on signal output pin <ul style="list-style-type: none"> U-phase winding wire negative ON/OFF switching pin ON: High, OFF: Low
16	NC	—	Not connected
17	OUT_VP	O	V-phase upper turn-on signal output pin <ul style="list-style-type: none"> V-phase winding wire positive ON/OFF switching pin ON: Low, OFF: High
18	NC	—	Not connected
19	OUT_VN	O	V-phase lower turn-on signal output pin <ul style="list-style-type: none"> V-phase winding wire negative ON/OFF switching pin ON: High, OFF: Low
20	NC	—	Not connected

Pin No.	Symbol	I/O	Description
21	OUT_WP	O	W-phase upper turn-on signal output pin <ul style="list-style-type: none"> W-phase winding wire positive ON/OFF switching pin ON: Low, OFF: High
22	OUT_WN	O	W-phase lower turn-on signal output pin <ul style="list-style-type: none"> W-phase winding wire negative ON/OFF switching pin ON: High, OFF: Low
23	OC	I	Overcurrent signal input pin <ul style="list-style-type: none"> High on this pin can put constraints on the turn-on signal performing PWM control. Built-in pull-up resistor
24	WAVE	I	Positional signal input pin <ul style="list-style-type: none"> Inputs majority logic synthesis signal of three-phase pin voltage. Built-in pull-up resistor

Functional Description

1. Sensorless Drive

On receipt of the start instruction by PWM signal, the turn-in signal for forcible commutation (commutation irrespective of the rotor position of the motor) is output and the motor starts to rotate. The rotation of the motor causes induced voltage on the wirewound pin for each phase.

When signals indicating positive or negative for pin voltage (including induced voltage) for each phase are input through their respective positional signal input pins, the turn-on signal for forcible commutation is automatically switched to the turn-on signal for the positional signal (induced voltage).

Thereafter, the turn-on signal is formed according to the induced voltage contained in the pin voltage so as to drive the brushless DC motor.

2. Starting Commutation Frequency (resonator pin and counter bit select pin)

The forcible commutation frequency at the time of start is determined by the resonator's frequency and the number of counter bits (within the IC).

$$\text{Starting commutation frequency } f_{st} = \text{Resonator frequency } f_{xt} / (6 \times 2^{(\text{bit} + 3)}) \quad \text{bits} = 14$$

The forcible commutation frequency at the time of start can be adjusted using the inertia of the motor and the load.

- The forcible commutation frequency should be set higher as the number of magnetic poles increases.
- The forcible commutation frequency should be set lower as the inertia of the load increases.

3. PWM Control

The PWM signal can be reflected in the turn-on signal by supplying the PWM signal from external sources.

The frequency of the PWM signal should be set adequately high with regard to the electrical frequency of the motor and in accordance with the switching characteristics of the drive circuit.

Because positional detection is performed in synchronization with the falling edges of the PWM signal, positional detection cannot be performed with 0% duty or 100% duty.

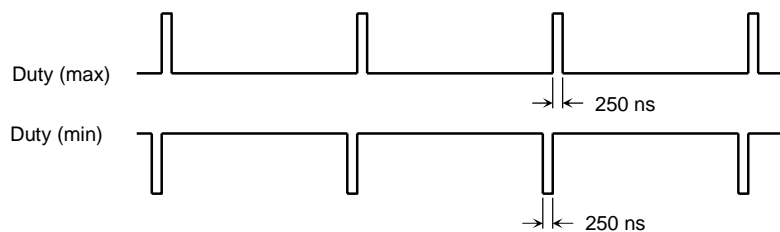

Even if the duty is 99%, the duty of the voltage applied to the motor is 100% owing to the storage time of the drive circuit.

4. PWM Control

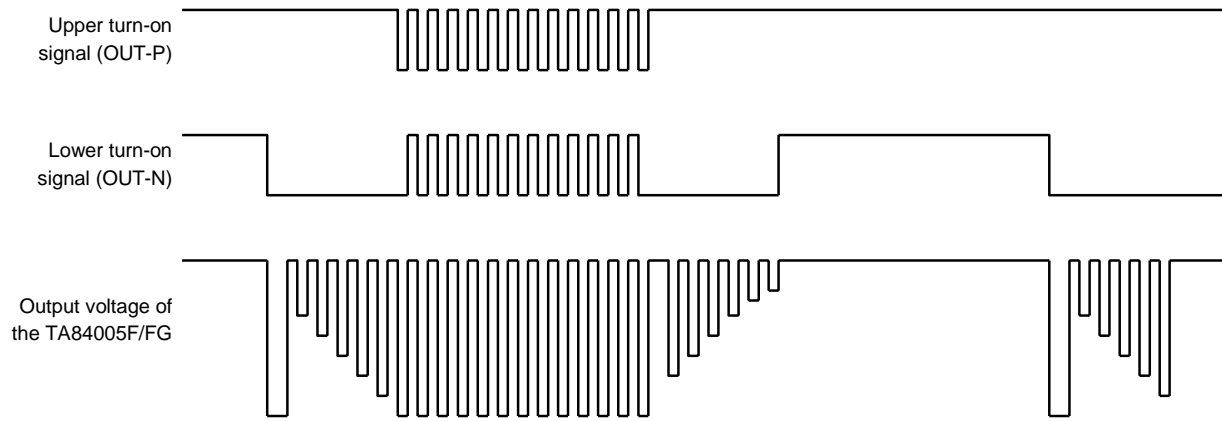

5. Positional Variation

Since positional detection is performed in synchronization with the PWM signal, positional variation occurs in connection with the frequency of the PWM signal. Take particular care if using the IC for high-speed motors.

Variation is calculated by detecting at two consecutive rising edges of the PWM signal.

$$1/f_p < \text{Detection time variation} < 2/f_p \quad f_p: \text{PWM frequency}$$

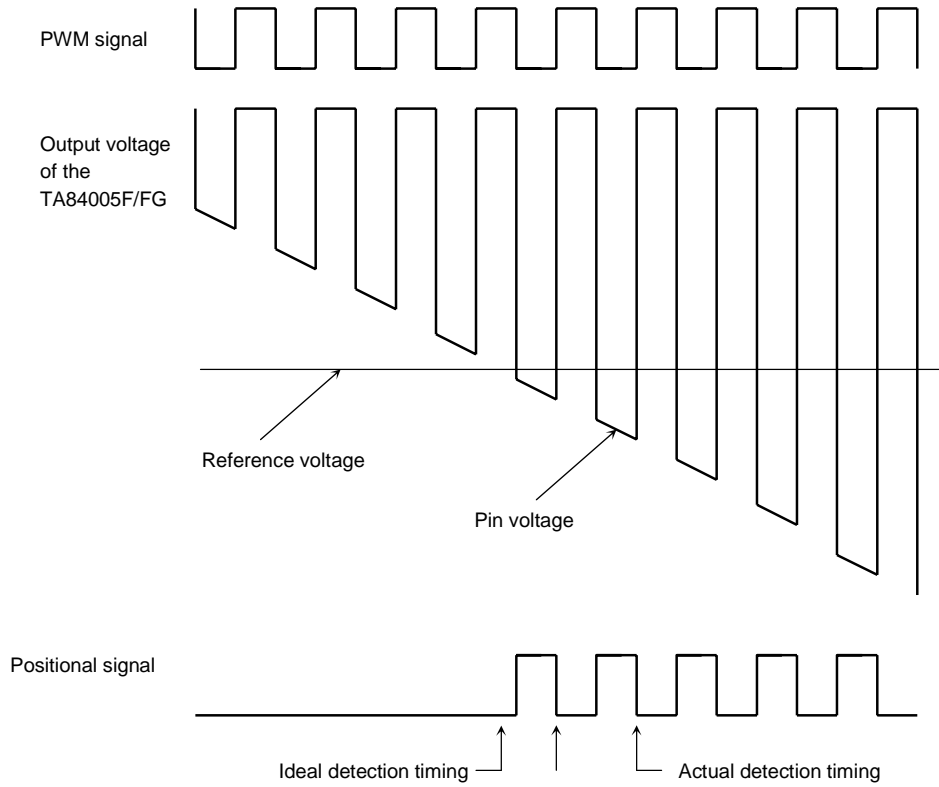

6. Lead Angle Control

The lead angle is 0 degrees during the starting forcible commutation and, when normal commutation is started, automatically changes to the lead angle that has been set using LA0 and LA1. However, if both LA0 and LA1 are set for High, the lead angle is 30 degrees in the starting forcible commutation as well as in normal commutation.

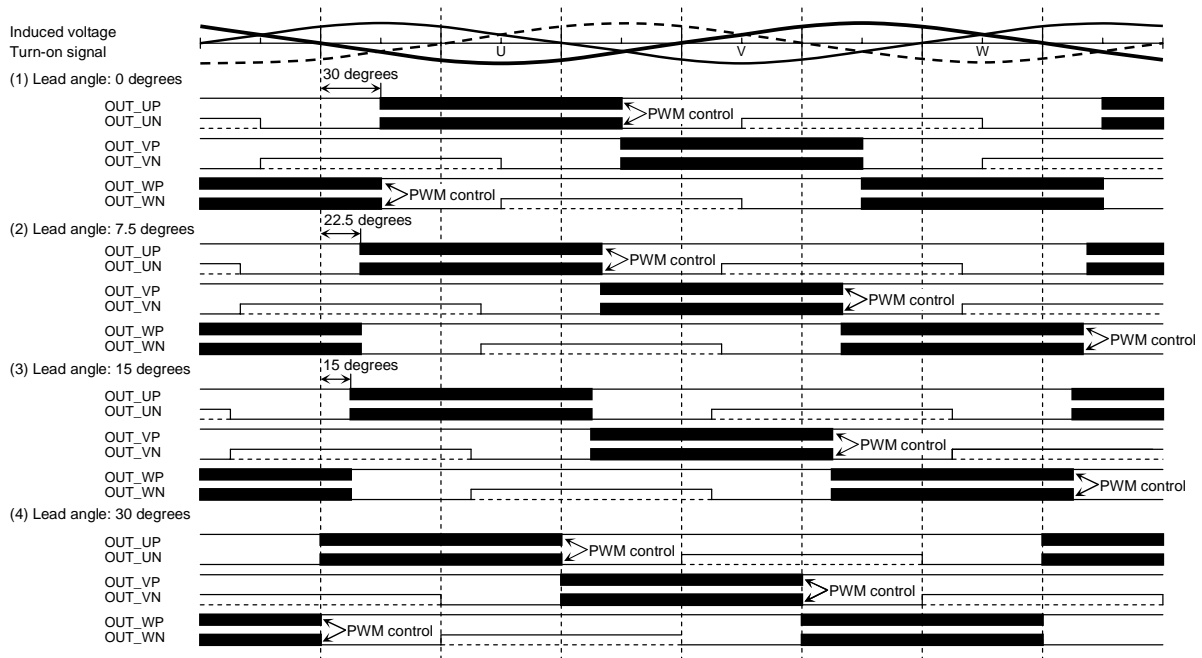

7. Lap Turn-on Control

When SEL_LAP = High, the turn-on electrical angle is 120 degrees. When SEL_LAP = Low, Lap Turn-on Mode starts.

In Lap Turn-on Mode, the time between zero-cross point and the 120-degree turn-on timing becomes longer (shaded area in the below chart) so as to create some overlap when switching turn-on signals. The lap time varies depending on the lead angle setting.

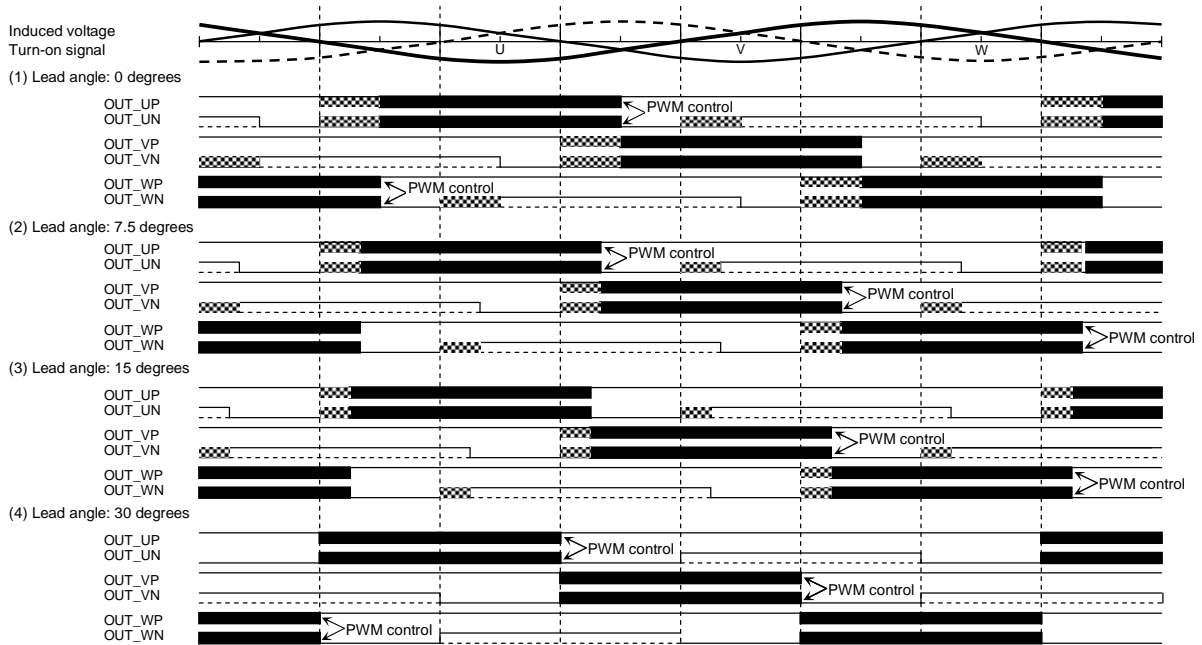

8. Start/Stop Control

Start/Stop is controlled using the PWM signal input pin.

A stop is acknowledged when the PWM signal duty is 0, and a start is acknowledged when the ON-signal of a frequency four times higher than the resonator frequency or greater is input continuously.

Timing chart

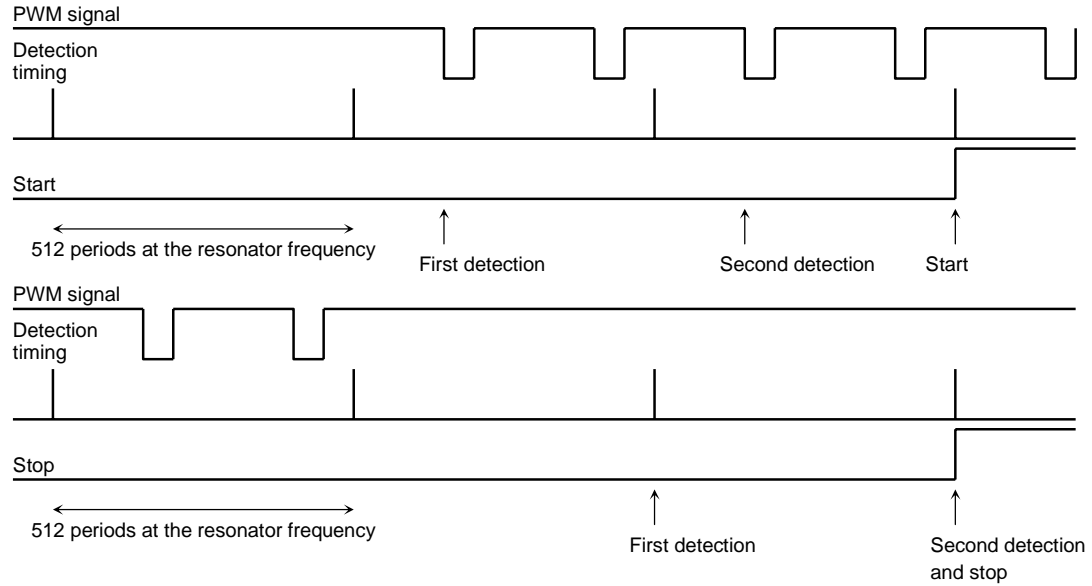

Note: Take sufficient care regarding noise on the PWM signal input pin.

Absolute Maximum Ratings (Ta = 25°C)

Characteristic	Symbol	Rating	Unit
Power supply voltage	V _{DD}	5.5	V
Input voltage	V _{in}	-0.3 to V _{DD} + 0.3	V
Turn-on signal output current	I _{OUT}	20	mA
Power dissipation	P _D	590	mW
Operating temperature	T _{opr}	-30 to 85	°C
Storage temperature	T _{stg}	-55 to 150	°C

Recommended Operating Conditions (Ta = -30 to 85°C)

Characteristic	Symbol	Test Condition	Min	Typ.	Max	Unit
Power supply voltage	V _{DD}	—	4.5	5.0	5.5	V
Input voltage	V _{in}	—	-0.3	—	V _{DD} + 0.3	V
PWM frequency	f _{PWM}	—	—	16	—	kHz
Oscillation frequency	f _{osc}	—	1.0	—	10	MHz

Electrical Characteristics (Ta = 25°C, VDD = 5 V)

Characteristic	Symbol	Test Circuit	Test Condition	Min	Typ.	Max	Unit
Static power supply current	I _{DD}	—	PWM = H, X _{Tin} = H	—	0.1	0.3	mA
Dynamic power supply current	I _{DD (opr)}	—	PWM = 50% Duty, X _{Tin} = 4 MHz	—	1	3	mA
Input current	I _{IN-1 (H)}	—	V _{IN} = 5 V, PWM, OC, WAVE_U, SEL_LAP	—	0	1	μA
	I _{IN-1 (L)}	—	V _{IN} = 0 V, PWM, OC, WAVE_U, SEL_LAP	-75	-50	—	
	I _{IN-2 (H)}	—	V _{IN} = 5 V, CW_CCW, LA0, LA1	—	50	75	
	I _{IN-2 (L)}	—	V _{IN} = 0 V, CW_CCW, LA0, LA1	-1	0	—	
Input voltage	V _{IN (H)}	—	PWM, OC, SEL_LAP, CW_CCW WAVE_U, LA0, LA1	3.5	—	5	V
	V _{IN (L)}	—	PWM, OC, SEL_LAP, CW_CCW WAVE_U, LA0, LA1	GND	—	1.5	
Input hysteresis voltage	V _H	—	PWM, OC, SEL_LAP, CW_CCW WAVE_U, LA0, LA1	—	0.6	—	V
Output voltage	V _{O-1 (H)}	—	I _{OH} = -1 mA OUT_UP, OUT_VP, OUT_WP	4.3	—	V _{DD}	V
	V _{O-1 (L)}	—	I _{OL} = 20 mA OUT_UP, OUT_VP, OUT_WP	GND	—	0.5	
	V _{O-2 (H)}	—	I _{OH} = -20 mA OUT_UN, OUT_VN, OUT_WN	4.0	—	V _{DD}	
	V _{O-2 (L)}	—	I _{OL} = 1 mA OUT_UN, OUT_VN, OUT_WN	GND	—	0.5	
	V _{O-3 (H)}	—	I _{OH} = -0.5 mA FG_OUT	4.0	—	V _{DD}	
	V _{O-3 (L)}	—	I _{OL} = 0.5 mA FG_OUT	GND	—	0.5	
Output leak current	I _{L (H)}	—	V _{DD} = 5.5 V, V _{OUT} = 0 V OUT_UP, OUT_VP, OUT_WP OUT_UN, OUT_VN, OUT_WN FG_OUT	—	0	10	μA
	I _{L (L)}	—	V _{DD} = 5.5 V, V _{OUT} = 5.5 V OUT_UP, OUT_VP, OUT_WP OUT_UN, OUT_VN, OUT_WN FG_OUT	—	0	10	
Output delay time	t _{pLH}	—	PWM-Output	—	0.5	1	μs
	t _{pHL}	—		—	0.5	1	

Application Circuit Example

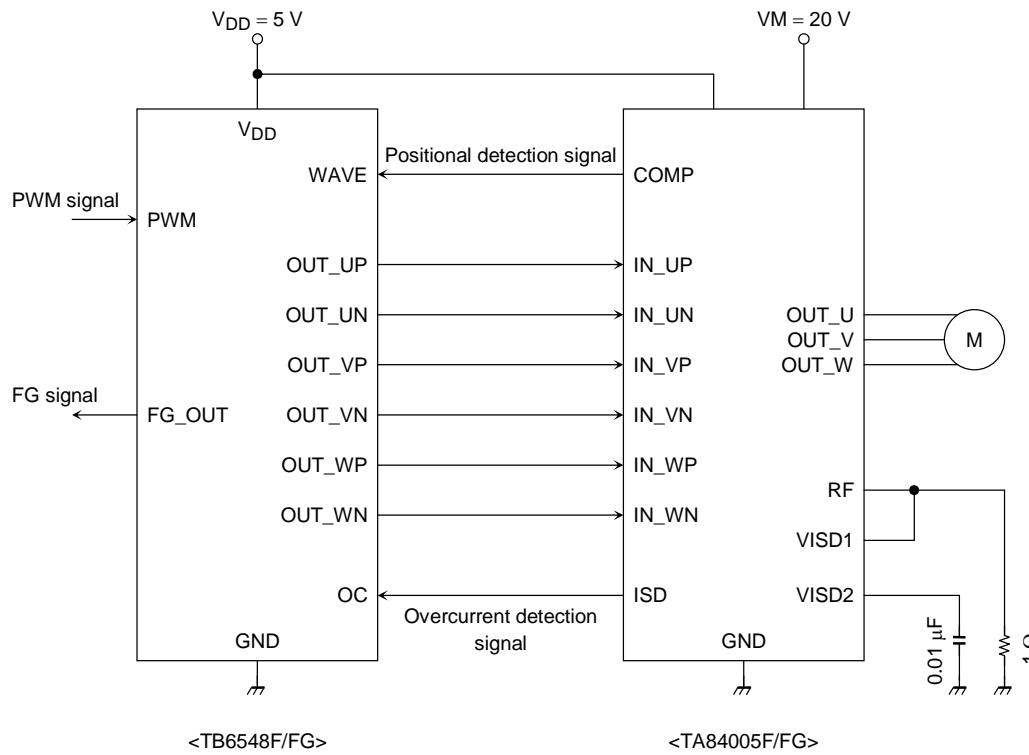

Note 1: Utmost care is necessary in the design of the output, V_{CC} , V_M , and GND lines since the IC may be destroyed by short-circuiting between outputs, air contamination faults, or faults due to improper grounding, or by short-circuiting between contiguous pins.

Note 2: The above application circuit and values mentioned are intended only as an example for reference. Since the values may vary depending on the motor to be used, appropriate values must be determined through experiment before use of the device.

Package Dimensions

SSOP24-P-300-1.00

Unit : mm

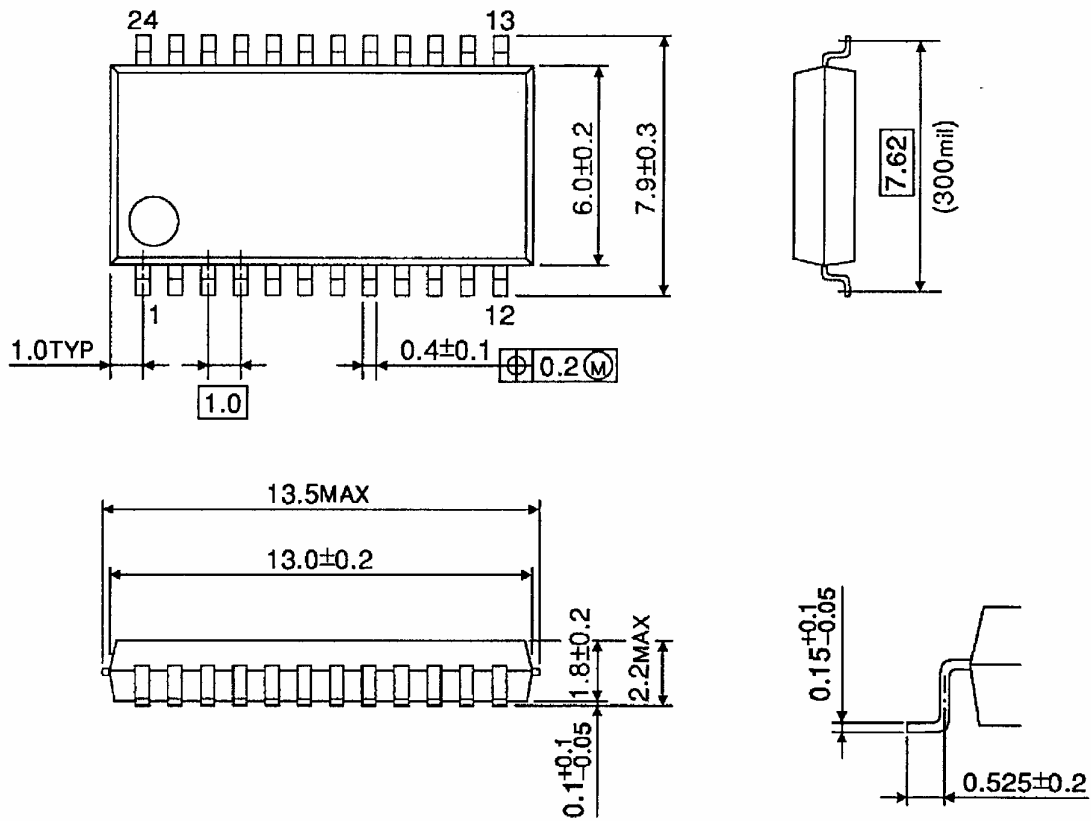

Weight: 0.32 g (typ.)

Notes on Contents

1. Block Diagrams

Some of the functional blocks, circuits, or constants in the block diagram may be omitted or simplified for explanatory purposes.

2. Equivalent Circuits

The equivalent circuit diagrams may be simplified or some parts of them may be omitted for explanatory purposes.

3. Timing Charts

Timing charts may be simplified for explanatory purposes.

4. Application Circuits

The application circuits shown in this document are provided for reference purposes only. Thorough evaluation is required, especially at the mass production design stage.

Toshiba does not grant any license to any industrial property rights by providing these examples of application circuits.

5. Test Circuits

Components in the test circuits are used only to obtain and confirm the device characteristics. These components and circuits are not guaranteed to prevent malfunction or failure from occurring in the application equipment.

IC Usage Considerations

Notes on handling of ICs

[1] The absolute maximum ratings of a semiconductor device are a set of ratings that must not be exceeded, even for a moment. Do not exceed any of these ratings.

Exceeding the rating(s) may cause the device breakdown, damage or deterioration, and may result injury by explosion or combustion.

[2] Do not insert devices in the wrong orientation or incorrectly.

Make sure that the positive and negative terminals of power supplies are connected properly.

Otherwise, the current or power consumption may exceed the absolute maximum rating, and exceeding the rating(s) may cause the device breakdown, damage or deterioration, and may result injury by explosion or combustion.

In addition, do not use any device that is applied the current with inserting in the wrong orientation or incorrectly even just one time.

Points to remember on handling of ICs

(1) Back-EMF

When a motor rotates in the reverse direction, stops or slows down abruptly, a current flow back to the motor's power supply due to the effect of back-EMF. If the current sink capability of the power supply is small, the device's motor power supply and output pins might be exposed to conditions beyond maximum ratings. To avoid this problem, take the effect of back-EMF into consideration in system design.

RESTRICTIONS ON PRODUCT USE

060116EBA

- The information contained herein is subject to change without notice. 021023_D
- TOSHIBA is continually working to improve the quality and reliability of its products. Nevertheless, semiconductor devices in general can malfunction or fail due to their inherent electrical sensitivity and vulnerability to physical stress. It is the responsibility of the buyer, when utilizing TOSHIBA products, to comply with the standards of safety in making a safe design for the entire system, and to avoid situations in which a malfunction or failure of such TOSHIBA products could cause loss of human life, bodily injury or damage to property.
In developing your designs, please ensure that TOSHIBA products are used within specified operating ranges as set forth in the most recent TOSHIBA products specifications. Also, please keep in mind the precautions and conditions set forth in the "Handling Guide for Semiconductor Devices," or "TOSHIBA Semiconductor Reliability Handbook" etc. 021023_A
- The TOSHIBA products listed in this document are intended for usage in general electronics applications (computer, personal equipment, office equipment, measuring equipment, industrial robotics, domestic appliances, etc.). These TOSHIBA products are neither intended nor warranted for usage in equipment that requires extraordinarily high quality and/or reliability or a malfunction or failure of which may cause loss of human life or bodily injury ("Unintended Usage"). Unintended Usage include atomic energy control instruments, airplane or spaceship instruments, transportation instruments, traffic signal instruments, combustion control instruments, medical instruments, all types of safety devices, etc. Unintended Usage of TOSHIBA products listed in this document shall be made at the customer's own risk. 021023_B
- The products described in this document shall not be used or embedded to any downstream products of which manufacture, use and/or sale are prohibited under any applicable laws and regulations. 060106_Q
- The information contained herein is presented only as a guide for the applications of our products. No responsibility is assumed by TOSHIBA for any infringements of patents or other rights of the third parties which may result from its use. No license is granted by implication or otherwise under any patent or patent rights of TOSHIBA or others. 021023_C
- The products described in this document are subject to the foreign exchange and foreign trade laws. 021023_E