

TA8231L

42W BTL×2CH AUDIO POWER IC

The TA8231L is BTL audio power amplifier for consumer application. It is designed for high power, low distortion and low noise.

It contains various kind of protectors and the function of stand-by.

FEATURE

- High Power
 - : $P_{OUT(1)} = 42W$ (Typ.)
($V_{CC} = 14.4V$, $f = 1kHz$, $THD = 10\%$, $R_L = 2\Omega$)
 - : $P_{OUT(2)} = 37W$ (Typ.)
($V_{CC} = 13.2V$, $f = 1kHz$, $THD = 10\%$, $R_L = 2\Omega$)
 - : $P_{OUT(3)} = 22W$ (Typ.)
($V_{CC} = 13.2V$, $f = 1kHz$, $THD = 10\%$, $R_L = 4\Omega$)
- Excellent Output Power Bandwidth
 - : $P_{OUT(4)} = 17W$ (Typ.)
($V_{CC} = 13.2V$, $f = 20Hz \sim 20kHz$, $THD = 1\%$, $R_L = 4\Omega$)
- Fixed Voltage Gain
 - : $G_V = 32dB$ (Typ.)
($V_{CC} = 13.2V$, $V_{out} = 0.775V_{rms}$ (0dBm))
- Low Thermal Resistance
 - : $\theta_{j-c} = 1.5^\circ C/W$ (Typ.)
- Low Distortion
 - : $THD = 0.02\%$ (Typ.)
($V_{CC} = 13.2V$, $f = 1kHz$, $P_{out} = 4W$, $R_L = 4\Omega$)
- Built-in Stand-by Switch Function
 - : $I_{STBY} = 100\mu A$ (Typ.)
(With pin① set at high, power is turned ON)
- Built-in Various Protection Circuit
 - : Thermal Shut Down, Over Voltage, Out to GND, Out to V_{CC} , Out to Out Short
- Operating Supply Voltage
 - : $V_{CC(opr)} = 9 \sim 18V$

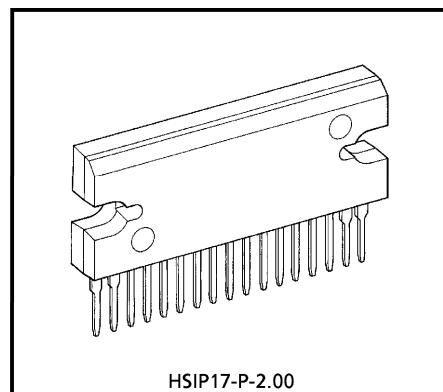

Weight : 9.8g (Typ.)

980508EBA2

- TOSHIBA is continually working to improve the quality and the reliability of its products. Nevertheless, semiconductor devices in general can malfunction or fail due to their inherent electrical sensitivity and vulnerability to physical stress. It is the responsibility of the buyer, when utilizing TOSHIBA products, to observe standards of safety, and to avoid situations in which a malfunction or failure of a TOSHIBA product could cause loss of human life, bodily injury or damage to property. In developing your designs, please ensure that TOSHIBA products are used within specified operating ranges as set forth in the most recent products specifications. Also, please keep in mind the precautions and conditions set forth in the TOSHIBA Semiconductor Reliability Handbook.
- The products described in this document are subject to foreign exchange and foreign trade laws.
- The information contained herein is presented only as a guide for the applications of our products. No responsibility is assumed by TOSHIBA CORPORATION for any infringements of intellectual property or other rights of the third parties which may result from its use. No license is granted by implication or otherwise under any intellectual property or other rights of TOSHIBA CORPORATION or others.
- The information contained herein is subject to change without notice.

BLOCK DIAGRAM

(G_V = 32dB)

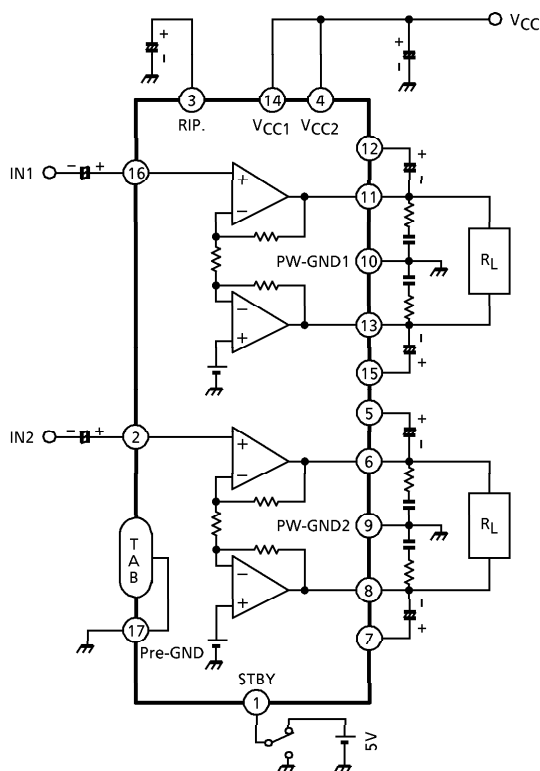

CAUTION AND APPLICATION METHOD

(Description is made only on the single channel.)

1. Voltage gain adjustment

This IC has no NF (negative feedback) terminals. Therefore, the voltage gain can't adjusted, but it makes the device a space and total costs saver.

The voltage gain is decided only internal by expression below.

$$G_V = 20 \log \frac{R_{f1}}{R_{f2}} + 6 \text{ (dB)} = 32 \text{ (dB)}$$

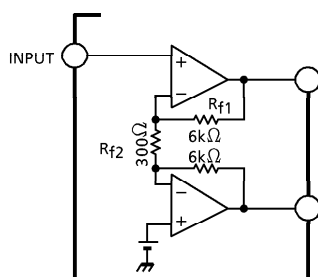

2. Stand-By SW Function

By means of controlling pin① (Stand-by terminal) to High and Low, the power supply can be set to ON and OFF. The threshold voltage of pin① is set at about 3V (Typ.), and the Power Supply current is about 100μA (Typ.) at the stand-by state.

Pin① Control Voltage : $V_{(SB)}$

Stand-By	Power	$V_{(SB)}$ (V)
ON	OFF	0~2
OFF	ON	3~ V_{CC}

~ Advantage of Stand-By SW ~

- (1) Since V_{CC} can directly be controlled to ON/OFF by the microcomputer, the switching relay can be omitted.
- (2) Since the control current is microscopic, the switching relay of small current capacity is satisfactory for switching.

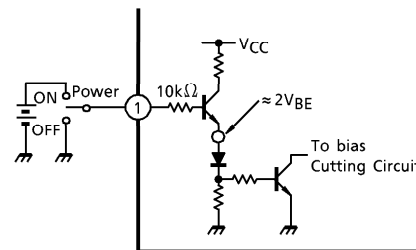
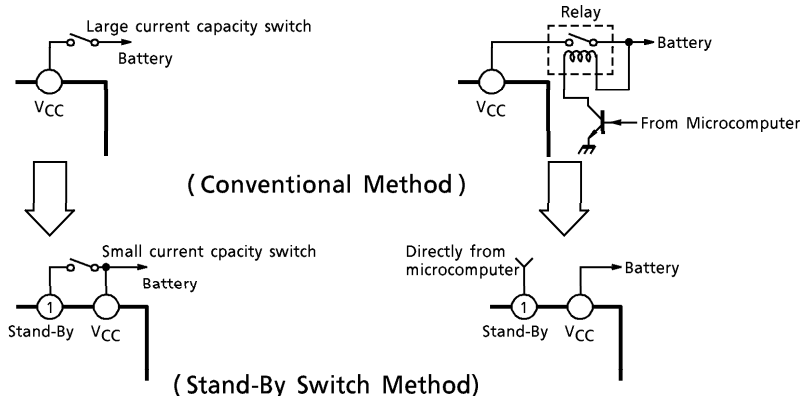

(Fig. 2) With pin① set to High, Power is turned ON.

3. Preventive measure against oscillation

For preventing the oscillation, it is advisable to use C4, the condenser of polyester film having small characteristic fluctuation of the temperature and the frequency. The resistance R to be series applied to C4 is effective for phase correction of high frequency, and improves the oscillation allowance. Since the oscillation allowance is varied according to the causes described below, perform the temperature test to check the oscillation allowance.

- (1) Capacity value of condenser
- (2) Kind of condenser
- (3) Layout of printed board

MAXIMUM RATING (Ta = 25°C)

CHARACTERISTIC	SYMBOL	RATING	UNIT
Peak Supply Voltage (0.2s)	V _{CC} (surge)	50	V
DC Supply Voltage	V _{CC} (DC)	25	V
Operating Supply Voltage	V _{CC} (opr)	18	V
Output Current (peak)	I _O (peak)	9	A
Power Dissipation	P _D	50	W
Operating Temperature	T _{opr}	-30~85	°C
Storage Temperature	T _{stg}	-55~150	°C

ELECTRICAL CHARACTERISTICS

(Unless Otherwise Specified V_{CC} = 13.2V, f = 1kHz, R_g = 600Ω, R_L = 4Ω, Ta = 25°C)

CHARACTERISTIC	SYMBOL	TEST CIR-CUIT	CONDITION	MIN	TYP.	MAX	UNIT
Quiescent Current	I _{ccq}	—	V _{in} = 0	—	150	250	mA
Output Power	P _{out} (1)	—	V _{CC} = 14.4V, THD = 10%, R _L = 2Ω	—	42	—	W
	P _{out} (2)	—	THD = 10%, R _L = 2Ω	28	37	—	W
	P _{out} (3)	—	THD = 10%, R _L = 4Ω	19	22	—	W
	P _{out} (4)	—	THD = 1%, f = 20Hz~20kHz, R _L = 4Ω	—	17	—	W
Total Harmonic Distortion	THD	—	P _{out} = 4W	—	0.02	0.2	%
Voltage Gain	G _V	—	V _{out} = 0.775V _{rms} (0dBm)	30.5	32	33.5	dB
Voltage Gain Ratio	ΔG _V	—	V _{out} = 0.775V _{rms} (0dBm)	-1	0	1	dB
Output Noise Voltage	V _{NO} (1)	—	R _g = 0Ω, DIN45405 Noise Filter	—	0.07	—	mV _{rms}
	V _{NO} (2)	—	R _g = 0Ω, BW = 20Hz~20kHz	—	0.06	0.1	mV _{rms}
Ripple Rejection Ratio	R.R.	—	f _{ripple} = 100Hz, V _{out} = 0.775V _{rms} (0dBm), R _g = 600Ω	40	60	—	dB
Cross Talk	C.T.	—	R _g = 600Ω, V _{out} = 0.775V _{rms} (0dBm)	—	60	—	dB
Input Resistance	R _{IN}	—	—	—	30	—	kΩ
Output Offset Voltage	V _{offset}	—	V _{in} = 0	-200	0	200	mV
Stand-By Current	I _{STBY}	—	Pin① : GND	—	100	150	μA

TEST CIRCUIT

(G_V = 32dB)

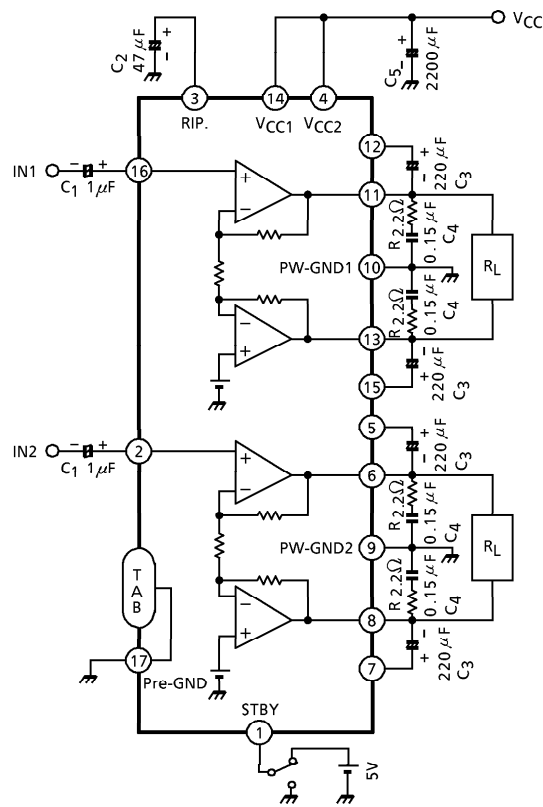

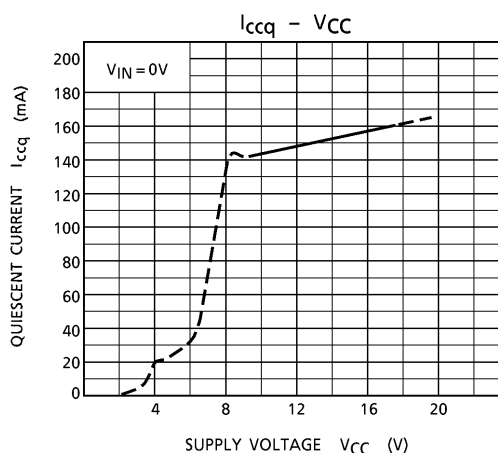
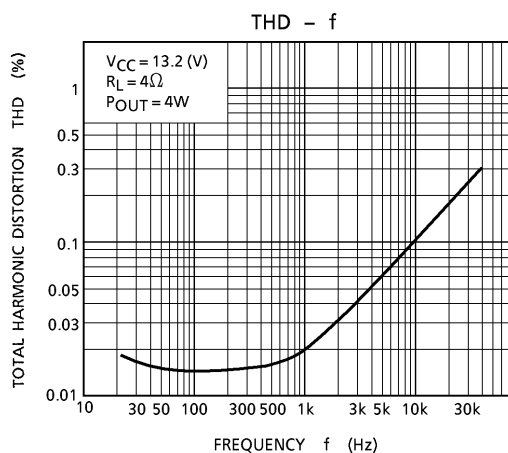
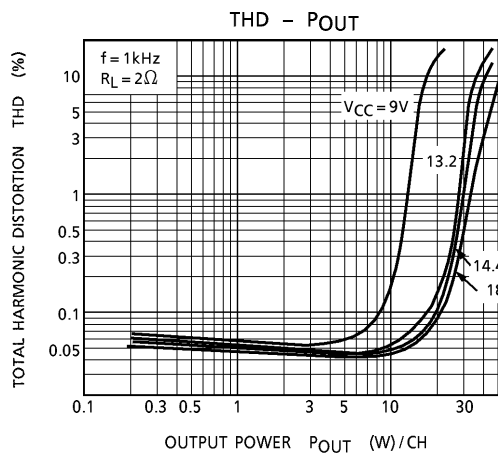
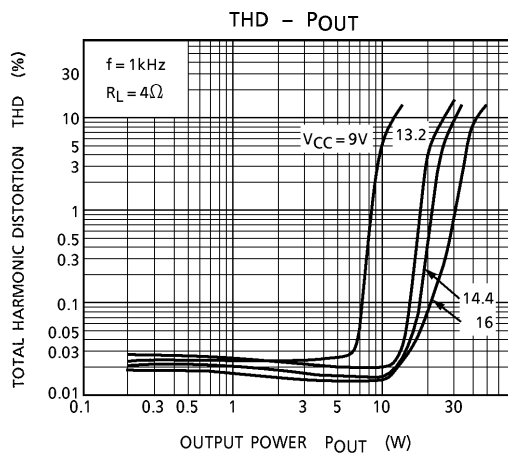
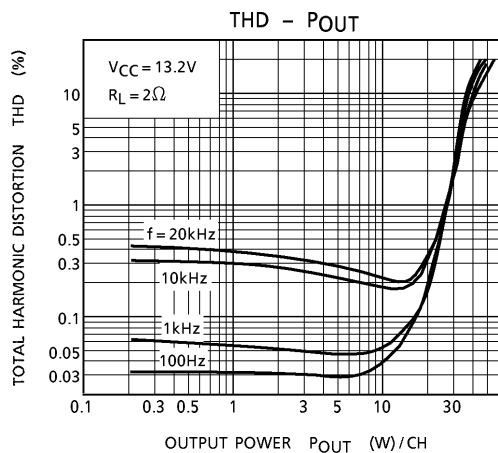
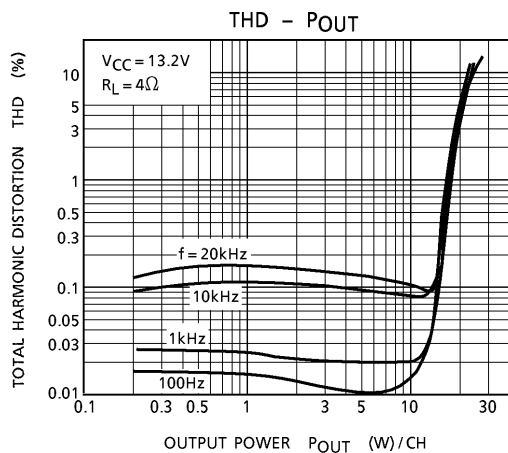

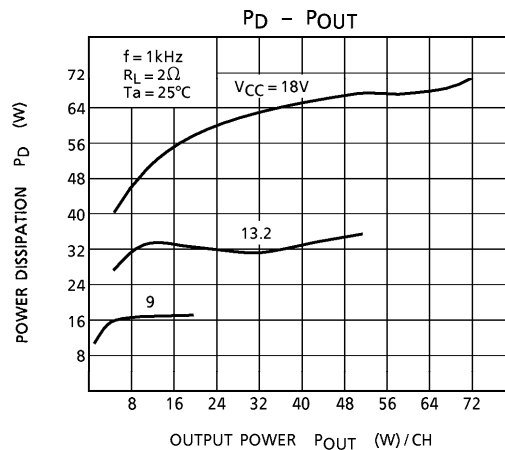
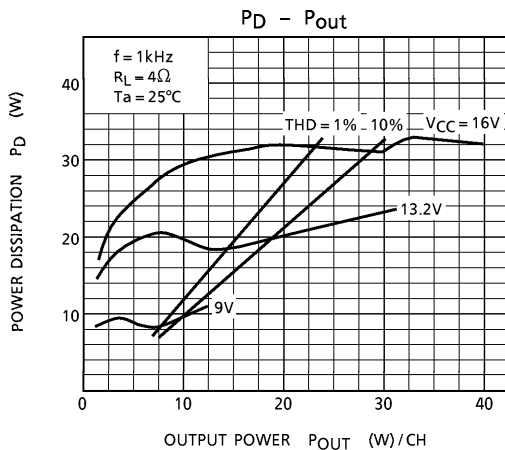
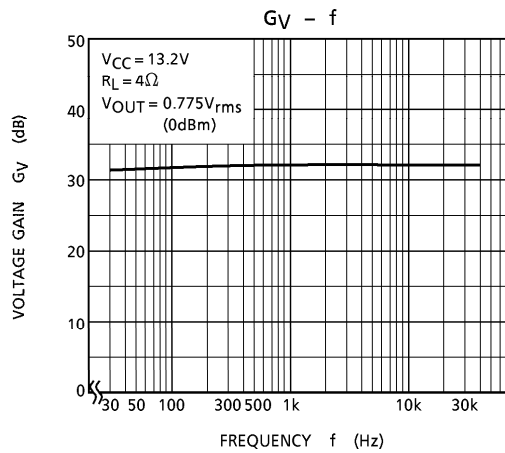
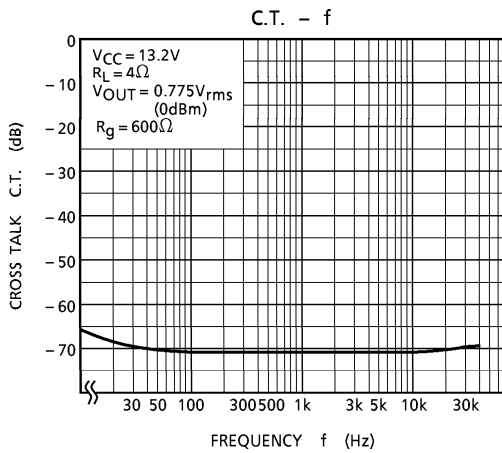
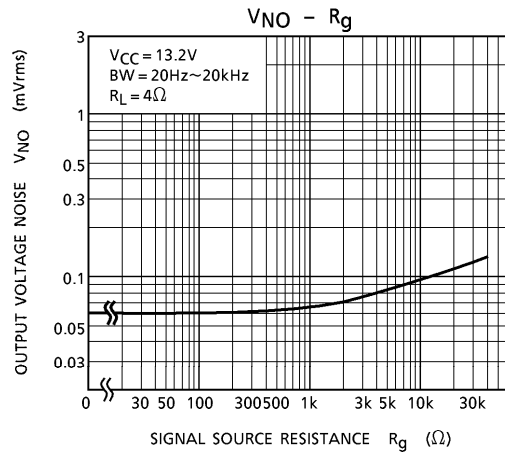
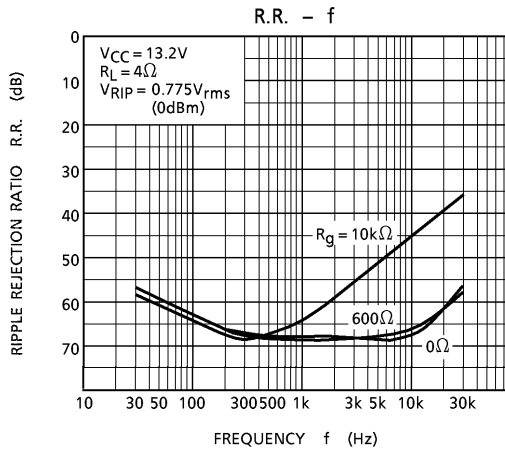

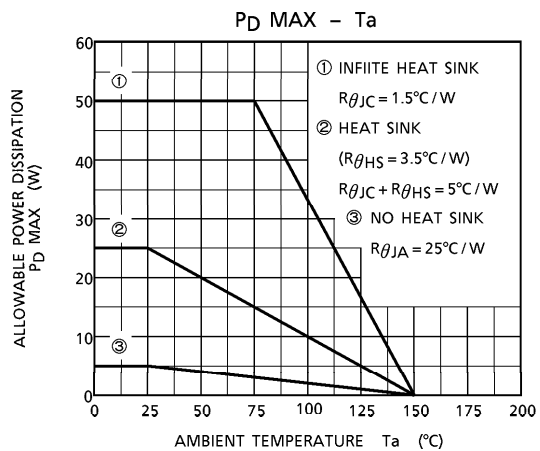

OUTLINE DRAWING
HSIP17-P-2.00

Unit : mm

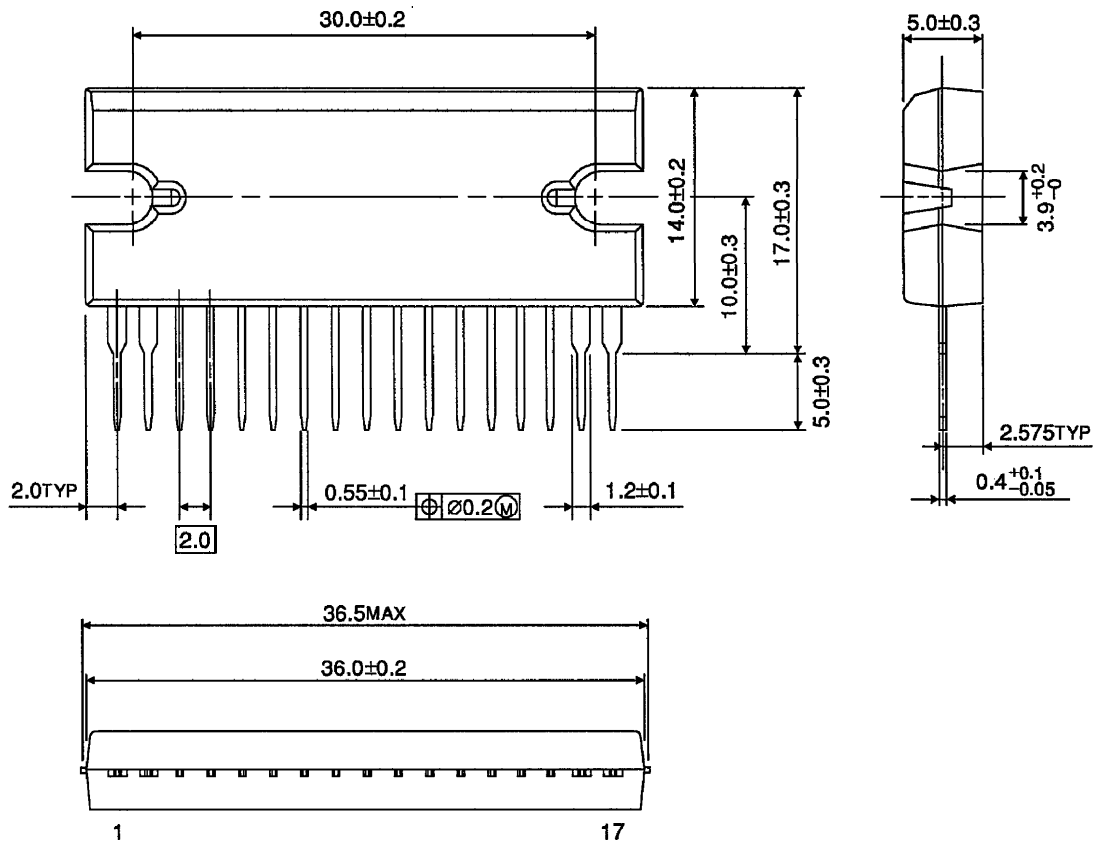

Weight : 9.8g (Typ.)