

TA8145FN

STEREO HEADPHONE AMPLIFIER (1.5V USE)

The TA8145FN is a stereo headphone power amplifier IC, which is developed for low voltage operation (1.5V). It is especially suitable for a stereo headphone cassette player.

FEATURES

- OCL (Output Condenser-Less)
- Built-in a ripple filter
- $G_V = 22\text{dB}$ (Typ.)
- Output power : $P_O = 8\text{mW}$ (Typ.)
($V_{CC} = 1.5\text{V}$, $R_L = 16\Omega$, $\text{THD} = 10\%$, $T_a = 25^\circ\text{C}$)
- Built-in a power switch.
- Built-in a power amplifier mute.
- Excellent ripple rejection ratio : $\text{RR} = 52\text{dB}$ (Typ.)
- Low noise : $V_{NO} = 27\mu\text{V}_{\text{rms}}$ (Typ.)
- Operating supply voltage range ($T_a = 25^\circ\text{C}$)
 $V_{CC(\text{opr})} = 0.9\sim 2.2\text{V}$

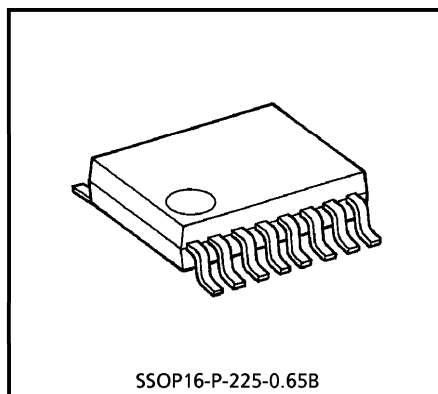

SSOP16-P-225-0.65B

Weight : 0.09g (Typ.)

BLOCK DIAGRAM

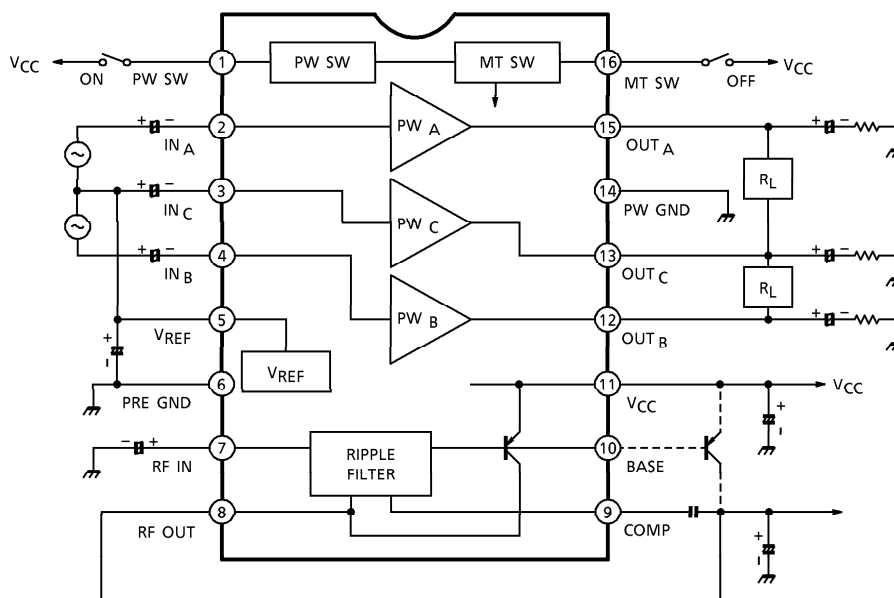

961001EBA2

● TOSHIBA is continually working to improve the quality and the reliability of its products. Nevertheless, semiconductor devices in general can malfunction or fail due to their inherent electrical sensitivity and vulnerability to physical stress. It is the responsibility of the buyer, when utilizing TOSHIBA products, to observe standards of safety, and to avoid situations in which a malfunction or failure of a TOSHIBA product could cause loss of human life, bodily injury or damage to property. In developing your designs, please ensure that TOSHIBA products are used within specified operating ranges as set forth in the most recent products specifications. Also, please keep in mind the precautions and conditions set forth in the TOSHIBA Semiconductor Reliability Handbook.

TERMINAL EXPLANATION

TERMINAL VOLTAGE : Typical terminal voltage at no signal with test circuit ($V_{CC} = 1.2V$, $T_a = 25^\circ C$)

TERMINAL		FUNCTION	INTERNAL CIRCUIT	TERMINAL VOLTAGE (V)
No.	NAME			
1	PW SW	Power on/off switch. V_{CC} : Power on GND/OPEN : Power off		—
16	MT SW	Muting switch. V_{CC} : Muting off GND/OPEN : Muting on		—
2	IN _A	Input of power amplifier		0.75
4	IN _B			
15	OUT _A	Output of power amplifier		0.6
12	OUT _B			
3	IN _C	Input of center amplifier		0.75
13	OUT _C	Output of center amplifier		0.6
5	V _{REF}	Reference voltage		0.75
6	PRE GND	—	—	0
7	RF IN	Ripple filter terminal		1.2

961001EBA2'

- The products described in this document are subject to foreign exchange and foreign trade control laws.
- The information contained herein is presented only as a guide for the applications of our products. No responsibility is assumed by TOSHIBA CORPORATION for any infringements of intellectual property or other rights of the third parties which may result from its use. No license is granted by implication or otherwise under any intellectual property or other rights of TOSHIBA CORPORATION or others.
- The information contained herein is subject to change without notice.

TERMINAL		FUNCTION	INTERNAL CIRCUIT	TERMINAL VOLTAGE (V)
No.	NAME			
8	RF OUT	Ripple filter output.		1.1
9	COMP	Phase-compensation terminal for a ripple filter circuit.		0.7
10	BASE	Base bias for an external PNP transistor of ripple filter.		0.5
11	V _{CC}	—		—
14	PW GND	—	—	0

APPLICATION NOTE

(1) Center amplifier

It is necessary to insert the coupling capacitor between the terminal of center amplifier input and V_{REF} , because it is necessary to stabilize the center amplifier circuit. Input signal should not be applied to the input terminal of center amplifier, because the internal circuit has unbalance and center amplifier doesn't operate normally.

(2) Power amplifier input

The input signal should be applied to power amplifier input through a coupling capacitor, because in case that DC current or DC voltage is applied to the terminal of IN_A (pin 2) and IN_B (pin 4), the internal circuit has unbalance and center amplifier doesn't operate normally.

(3) Muting switch

The leak current flows through the terminal of MT SW (pin 16), in case that the terminal is connected with V_{CC} line independently, even though this IC is off-mode (the terminal of PW SW (pin 1) is off-mode).

(4) Power switch

It is necessary to connect an external pull-down resistor with the terminal of PW SW (pin 1), in case that this IC is turned on due to external noise etc.

MAXIMUM RATINGS (Ta = 25°C)

CHARACTERISTIC		SYMBOL	RATING	UNIT
Supply Voltage		V _{CC}	4.5	V
Output Current	Power amplifier	I _O (peak)	60	mA
	Ripple Filter (Built-in transistor)	I _{RF}	5	
Power Dissipation (Note)		P _D	400	mW
Operating Temperature		T _{opr}	-25~75	°C
Storage Temperature		T _{stg}	-55~150	

Note : Derated above Ta = 25°C in the proportion of 3.2mW/°C.

ELECTRICAL CHARACTERISTICS

Unless otherwise specified. V_{CC} = 1.2V, R_L = 16Ω, R_g = 600Ω, f = 1kHz, Ta = 25°C
 SW₁ : a, SW₂ : a, SW₃ : a, SW₄ : ON, SW₅ : ON

CHARACTERISTIC		SYMBOL	TEST CIRCUIT	TEST CONDITION	MIN.	TYP.	MAX.	UNIT
Quiescent Current		I _{CCO1}	—	Power off, SW ₁ : b, SW ₂ : b	—	0.1	5	μA
		I _{CCO2}	—	Mute on, SW ₂ : b	—	1.6	3	mA
		I _{CCO3}	—	V _{in} = 0, SW ₃ : b	—	10	14	
Power Amplifier	Voltage Gain	G _V	—	V _O (A) = V _O (B) = -22dBV	20	22	24	dB
	Channel Balance	CB	—	V _O = -22dBV	—	0	1.5	
	Output Power	P _O	—	V _{CC} = 1.5V, THD = 10% V _{in} (A) = V _{in} (B)	5	8	—	mW
	Total Harmonic Distortion	THD	—	V _{CC} = 1V P _O (A) = P _O (B) = 0.5mW	—	0.7	1.5	%
	Output Noise Voltage	V _{no}	—	SW ₃ : b, BPF = 20Hz~20kHz	—	27	40	μV _{rms}
	Cross Talk	CT	—	V _O = -22dBV	31	37	—	dB
	Ripple Rejection Ratio	RR1	—	V _{CC} = 1V, f _r = 100Hz V _r = -32dBV, SW ₄ : OPEN	45	52	—	
Muting Attenuation	ATT	—	V _O = -22dBV, SW ₂ : a→b	65	80	—		
Ripple Filter Output Voltage		V _{RF}	—	V _{CC} = 1V, I _{RF} = 30mA	0.86	0.9	—	V
Ripple Rejection Ratio Of Ripple Filter Output		RR2	—	V _{CC} = 1V, I _{RF} = 30mA f _r = 100Hz, V _r = -32dBV SW ₄ : OPEN	30	37	—	dB
Power Switch	Power On Current	I ₁	—	V _{CC} = 0.9V, V ₅ ≥ 0.5V, SW ₁ : c	5	—	—	μA
	Power Off Voltage	V ₁	—	V _{CC} = 0.9V, V ₅ ≤ 0.1V SW ₁ : d	0	—	0.3	V
Mute Switch	Mute Off Current	I ₁₆	—	V _{CC} = 0.9V, V ₁₃ ≥ 0.3V, SW ₂ : c	5	—	—	μA
	Mute On Voltage	V ₁₆	—	V _{CC} = 0.9V, V ₁₃ ≤ 0.3V SW ₂ : d	0	—	0.3	V

TEST CIRCUIT

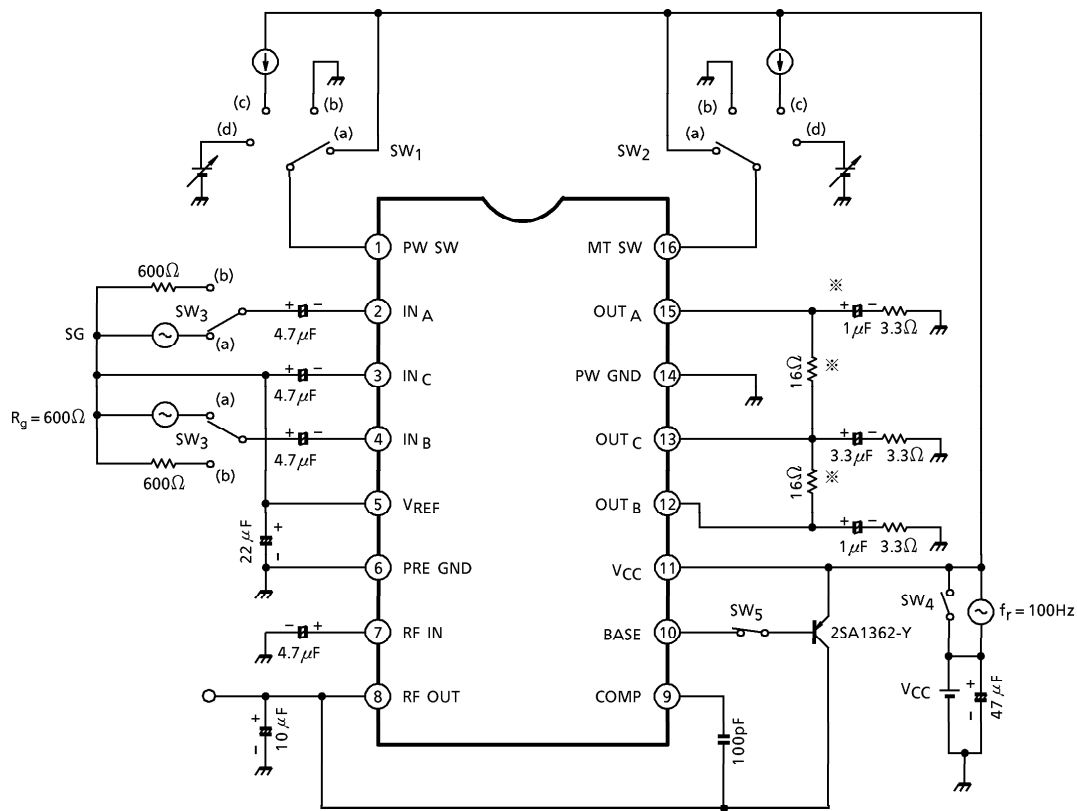

※ Tantalum condenser

CHARACTERISTICS CURVES

Unless otherwise specified, $V_{CC} = 1.2V$, $R_g = 600\Omega$, $f = 1kHz$, $R_L = 16\Omega$, $T_a = 25^\circ C$

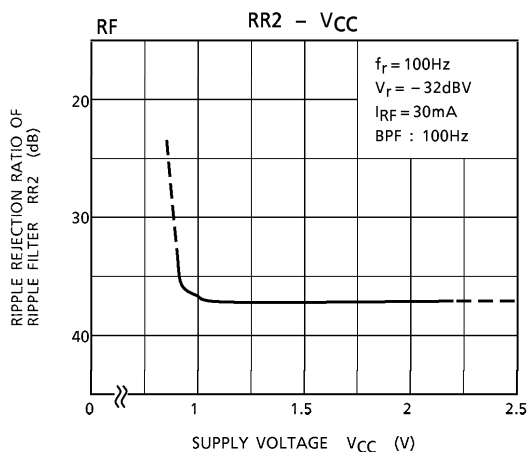
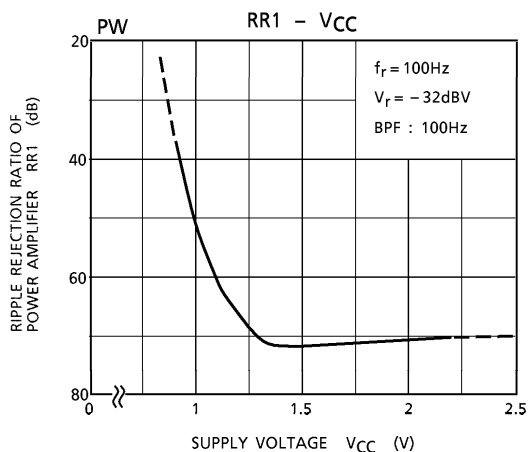
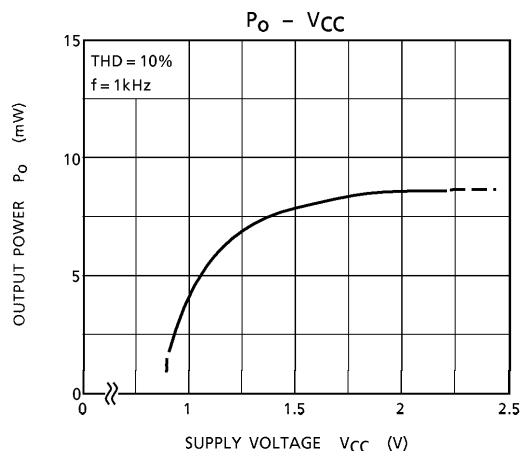
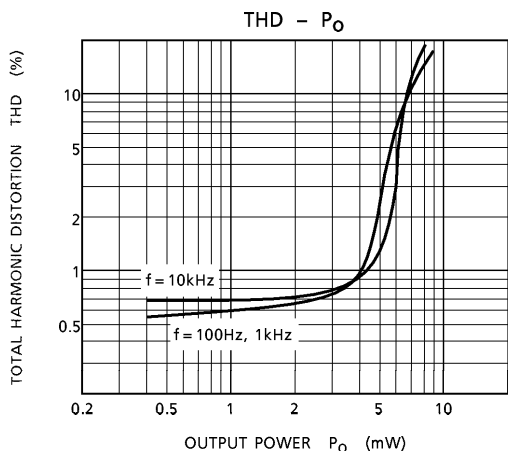
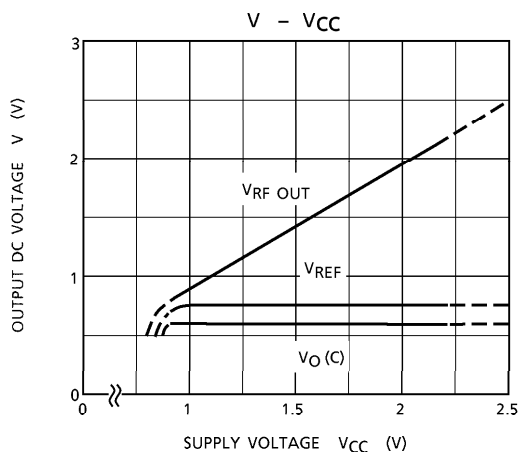
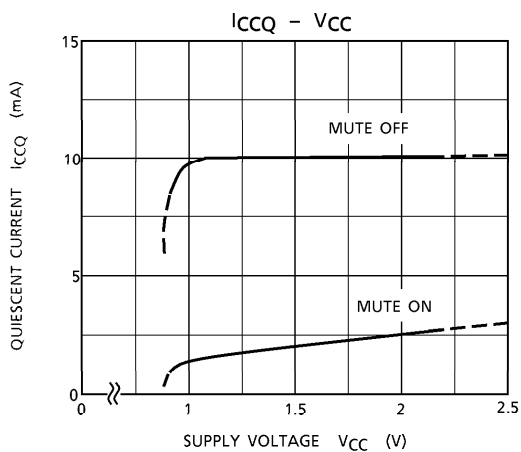

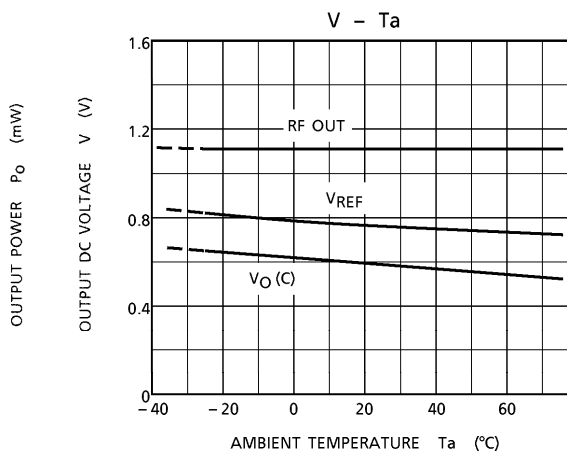
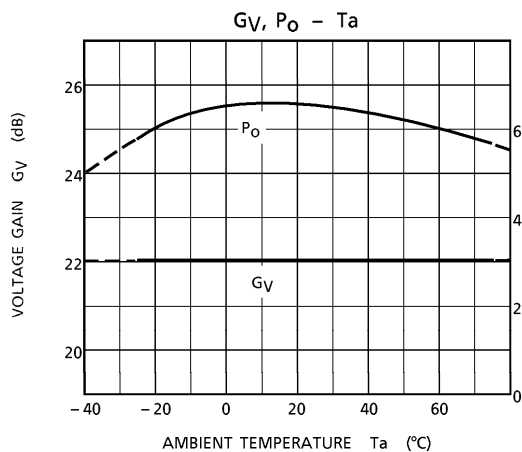
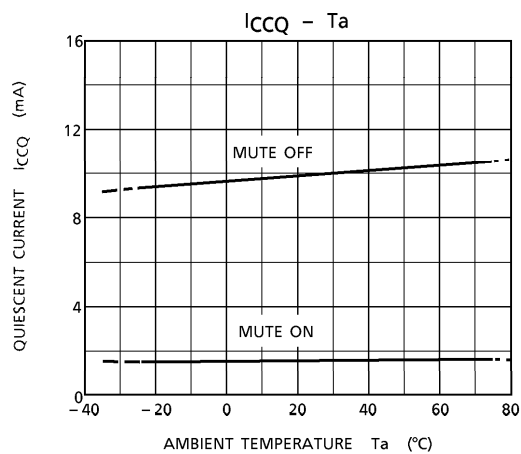
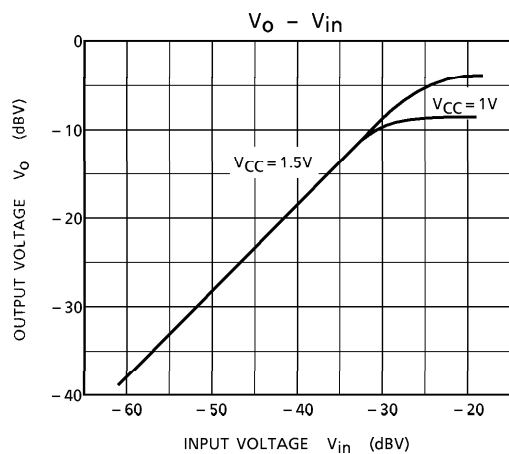
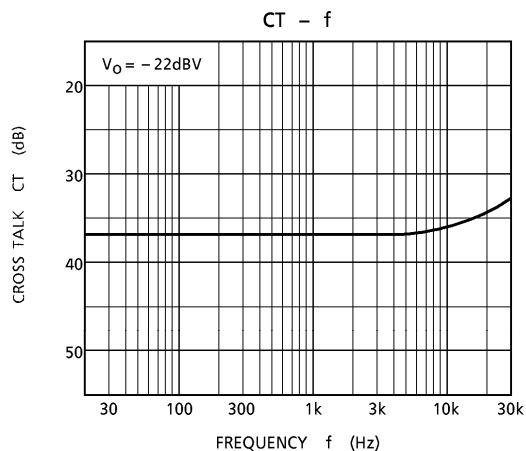
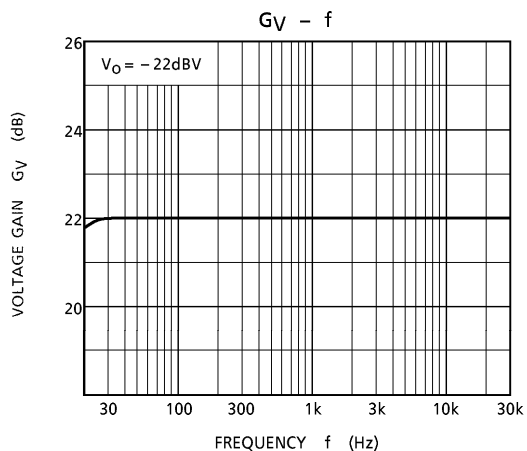

OUTLINE DRAWING
SSOP16-P-225-0.65B

Unit : mm

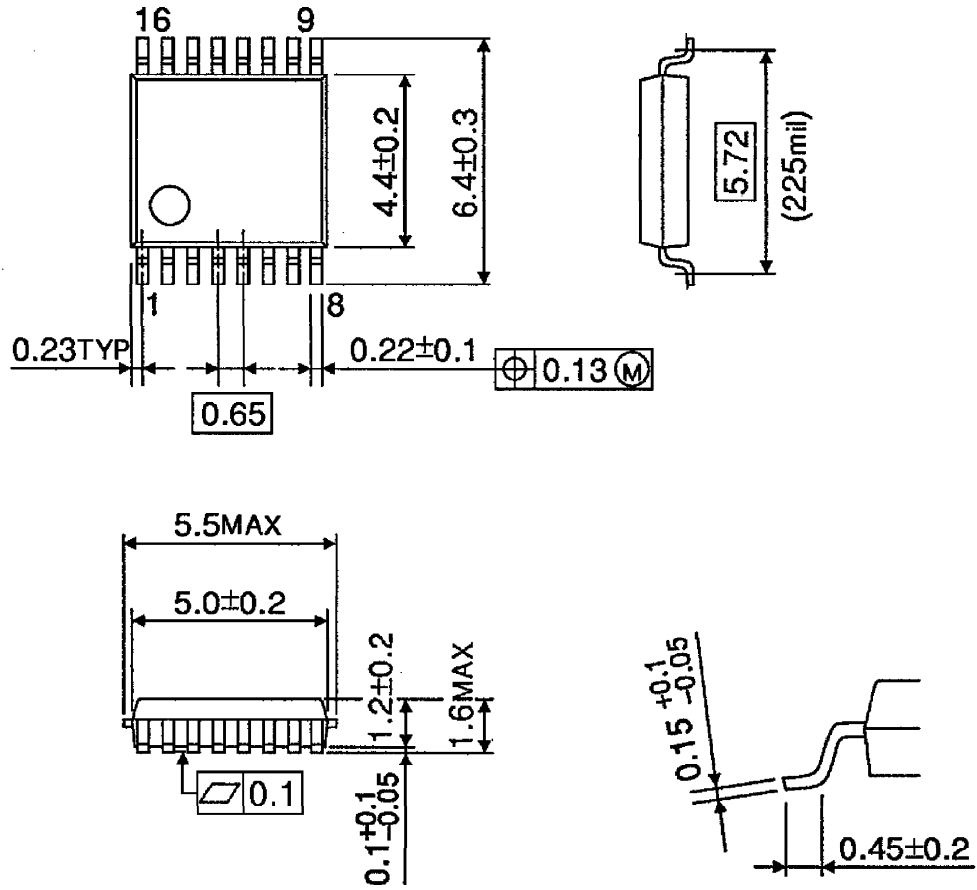

Weight : 0.09g (Typ.)