

DUAL FULL-BRIDGE PWM MOTOR DRIVER

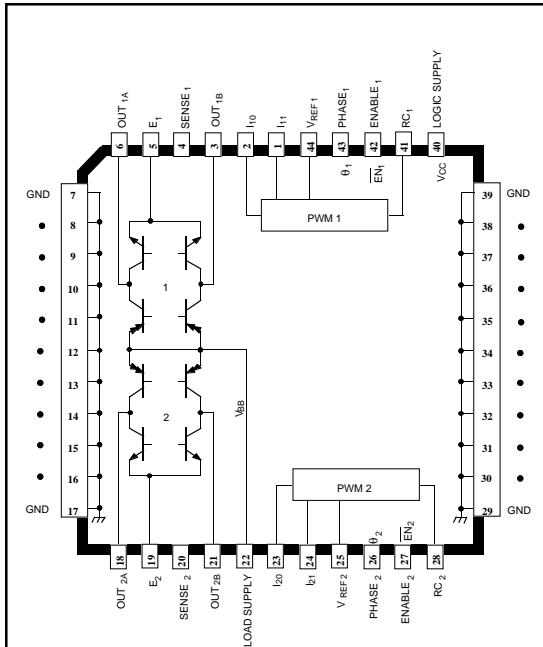

Dwg. PP-021

ABSOLUTE MAXIMUM RATINGS at $T_j \leq +150^\circ\text{C}$

| | |
|---|--|
| Motor Supply Voltage, V_{BB} | 45 V |
| Output Current, I_{OUT} ($t_w \leq 20 \mu\text{s}$) | $\pm 1.75 \text{ A}$ |
| (Continuous) | $\pm 1.5 \text{ A}$ |
| Logic Supply Voltage, V_{CC} | 7.0 V |
| Logic Input Voltage Range, V_{IN} | -0.3 V to +7.0 V |
| Output Emitter Voltage, V_E | 1.0 V |
| Package Power Dissipation, P_D | See Graph |
| Operating Temperature Range, T_A | -20°C to $+85^\circ\text{C}$ |
| Storage Temperature Range, T_S | -55°C to $+150^\circ\text{C}$ |

Output current rating may be limited by duty cycle, ambient temperature, and heat sinking. Under any set of conditions, do not exceed the specified peak current rating or a junction temperature of $+150^\circ\text{C}$.

The UDN2917EB motor driver is designed to drive both windings of a bipolar stepper motor or bidirectionally control two dc motors. Both bridges are capable of sustaining 45 V and include internal pulse-width modulation (PWM) control of the output current to 1.5 A.

For PWM current control, the maximum output current is determined by the user's selection of a reference voltage and sensing resistor. Two logic-level inputs select output current limits of 0, 33%, 67%, or 100% of the maximum level. A PHASE input to each bridge determines load current direction. Active-low ENABLE inputs control the four drivers in each bridge.

The bridges include both ground clamp and flyback diodes for protection against inductive transients. Internally generated delays prevent cross-over currents when switching current direction. Special power-up sequencing is not required. Thermal protection circuitry disables the outputs if the chip temperature exceeds safe operating limits.

The UDN2917EB is supplied in a 44-lead power PLCC for surface-mount applications. Its batwing construction provides for maximum package power dissipation in the smallest possible construction. The UDN2917EB is provided for operation over an ambient temperature range of -20°C to $+85^\circ\text{C}$.

FEATURES

- 1.5 A Continuous Output Current
- 45 V Output Sustaining Voltage
- Internal Clamp Diodes
- Digital Control of Output Current
- Internal Thermal Shutdown Circuitry
- Similar to Dual PBL3770

Always order by complete part number: **UDN2917EB** .

2917 DUAL FULL-BRIDGE PWM MOTOR DRIVER

PWM CURRENT-CONTROL CIRCUITRY

CHANNEL 1
PIN NUMBERS
SHOWN.

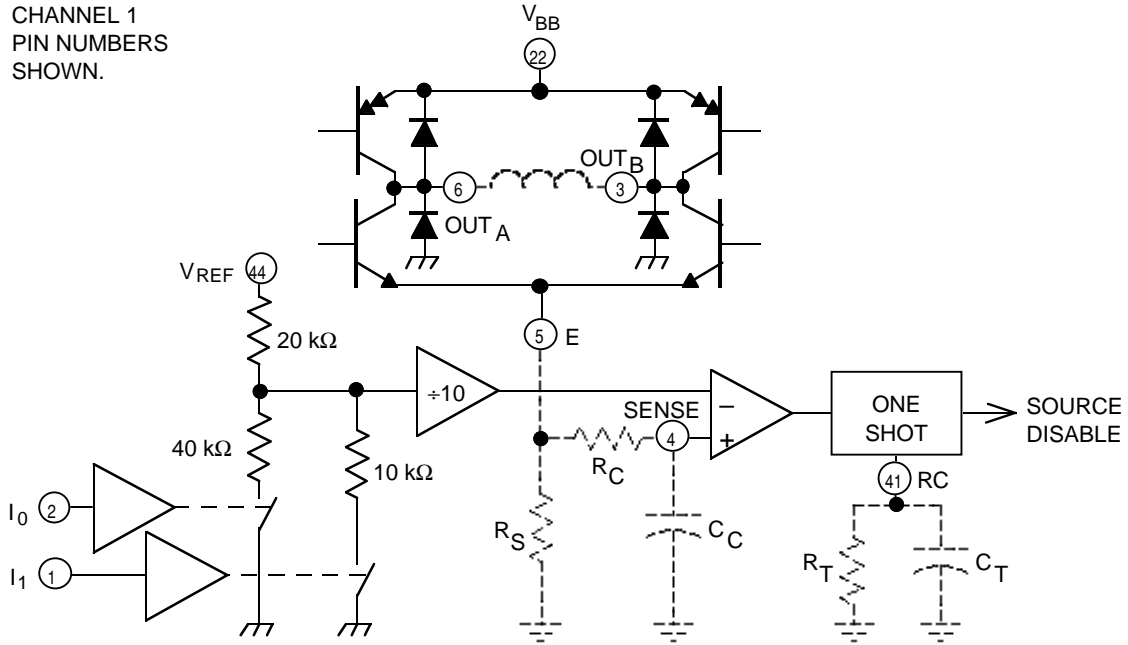

Dwg. EP-007-2A

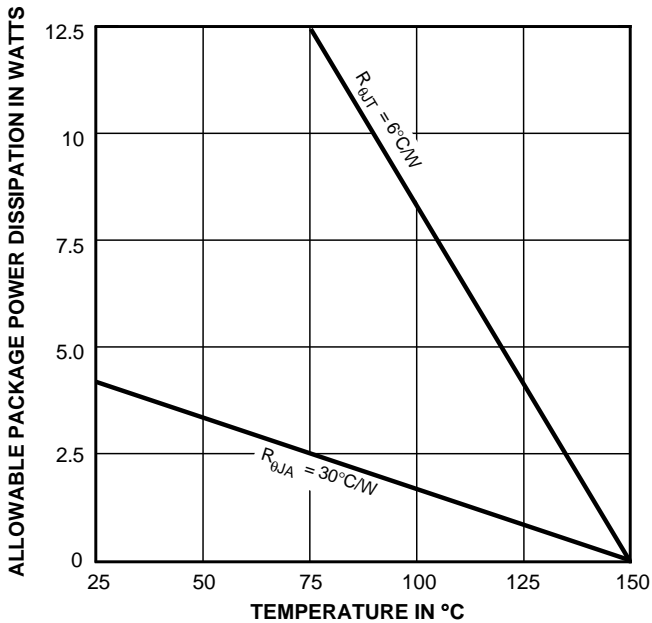

Dwg. GP-020B

TRUTH TABLE

| Enable | Phase | Out _A | Out _B |
|--------|-------|------------------|------------------|
| L | H | H | L |
| L | L | L | H |
| H | X | Z | Z |

X = Don't care

Z = High impedance



115 Northeast Cutoff, Box 15036
Worcester, Massachusetts 01615-0036 (508) 853-5000
Copyright © 1991, 2004 Allegro MicroSystems, Inc.

2917 DUAL FULL-BRIDGE PWM MOTOR DRIVER

ELECTRICAL CHARACTERISTICS at $T_A = +25^\circ\text{C}$, $V_{BB} = 45\text{ V}$, $V_{CC} = 5.0\text{ V}$, $V_{REF} = 5.0\text{ V}$ (unless otherwise noted).

| Characteristic | Symbol | Test Conditions | Limits | | | Units |
|--|---------------|--|--------|-------|------|---------------|
| | | | Min. | Typ. | Max. | |
| Output Drivers (OUT_A or OUT_B) | | | | | | |
| Motor Supply Range | V_{BB} | | 10 | — | 45 | V |
| Output Leakage Current | I_{CEX} | $V_{OUT} = V_{BB}$ | — | <1.0 | 50 | μA |
| | | $V_{OUT} = 0$ | — | <-1.0 | -50 | μA |
| Output Sustaining Voltage | $V_{CE(sus)}$ | $I_{OUT} = \pm 1.5\text{ A}$, $L = 3.5\text{ mH}$ | 45 | — | — | V |
| Output Saturation Voltage | $V_{CE(SAT)}$ | Sink Driver, $I_{OUT} = +1.0\text{ A}^*$ | — | 0.5 | 0.7 | V |
| | | Sink Driver, $I_{OUT} = +1.5\text{ A}^*$ | — | 0.8 | 1.0 | V |
| | | Source Driver, $I_{OUT} = -1.0\text{ A}^*$ | — | 1.8 | 1.9 | V |
| | | Source Driver, $I_{OUT} = -1.5\text{ A}^*$ | — | 1.9 | 2.1 | V |
| Clamp Diode Leakage Current | I_R | $V_R = 45\text{ V}$ | — | <1.0 | 50 | μA |
| Clamp Diode Forward Voltage | V_F | $I_F = 1.5\text{ A}$ | — | 1.6 | 2.0 | V |
| Driver Supply Current | $I_{BB(ON)}$ | Both Bridges On, No Load | — | 9.0 | 12 | mA |
| | $I_{BB(OFF)}$ | Both Bridges Off | — | 4.0 | 6.0 | mA |

Control Logic

| | | | | | | |
|--|---------------------|---|------|------|------|------------------|
| Input Voltage | $V_{IN(1)}$ | All Inputs | 2.4 | — | — | V |
| | $V_{IN(0)}$ | All Inputs | — | — | 0.8 | V |
| Input Current | $I_{IN(1)}$ | $V_{IN} = 2.4\text{ V}$ | — | <1.0 | 20 | μA |
| | $I_{IN(0)}$ | $V_{IN} = 0.8\text{ V}$ | — | -3.0 | -200 | μA |
| Reference Voltage Range | V_{REF} | Operating | 1.5 | — | 7.5 | V |
| Current Limit Threshold (at trip point) | V_{REF}/V_{SENSE} | $I_0 = I_1 = 0.8\text{ V}$ | 9.5 | 10 | 10.5 | — |
| | | $I_0 = 2.4\text{ V}$, $I_1 = 0.8\text{ V}$ | 13.5 | 15 | 16.5 | — |
| | | $I_0 = 0.8\text{ V}$, $I_1 = 2.4\text{ V}$ | 25.5 | 30 | 34.5 | — |
| Thermal Shutdown Temp. | T_J | | — | 170 | — | $^\circ\text{C}$ |
| Total Logic Supply Current | $I_{CC(ON)}$ | $I_0 = I_1 = V_{EN} = 0.8\text{ V}$, No Load | — | 90 | 105 | mA |
| | $I_{CC(OFF)}$ | $I_0 = I_1 = 2.4\text{ V}$, No Load | — | 10 | 12 | mA |

Negative current is defined as coming out of (sourcing) the specified device pin.

Typical Data is for design information only.

* Pulse test (<10 ms).

2917 DUAL FULL-BRIDGE PWM MOTOR DRIVER

APPLICATIONS INFORMATION

PWM CURRENT CONTROL

The UDN2917EB dual bridge is designed to drive both windings of a bipolar stepper motor. Output current is sensed and controlled independently in each bridge by an external sense resistor (R_S), internal comparator, and monostable multivibrator.

When the bridge is turned on, current increases in the motor winding and it is sensed by the external sense resistor until the sense voltage (V_{SENSE}) reaches the level set at the comparator's input:

$$I_{TRIP} = V_{REF} / 10 R_S$$

The comparator then triggers the monostable which turns off the source driver of the bridge. The actual load current peak will be slightly higher than the trip point (especially for low-inductance loads) because of the internal logic and switching delays. This delay (t_d) is typically 2 μ s. After turn-off, the motor current will normally decay, circulating through the ground clamp diode and sink transistor. The source driver's off time (and therefore the magnitude of the current decrease) is determined by the monostable's external RC timing components, where $t_{off} = R_T C_T$ within the range of 20 k Ω to 100 k Ω and 200 pF to 500 pF.

When the source driver is re-enabled, the winding current (the sense voltage) is again allowed to rise to the comparator's threshold. This cycle repeats itself, maintaining the average motor winding current at the desired level.

Special circuitry has been included to prevent runaway current control when the fixed off time (t_{off}) is set too short. This circuitry prevents the source driver from being re-enabled until the load current has decayed to below the I_{TRIP} level.

PWM OUTPUT CURRENT WAVEFORM

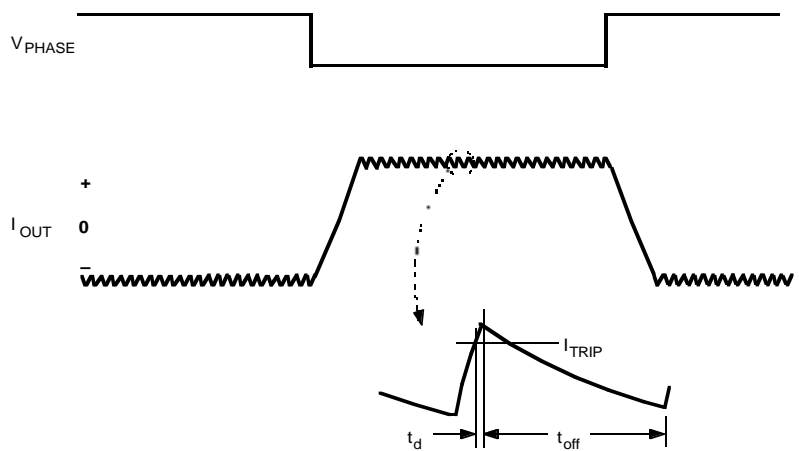

Dwg. WM-003-1A

LOAD CURRENT PATHS

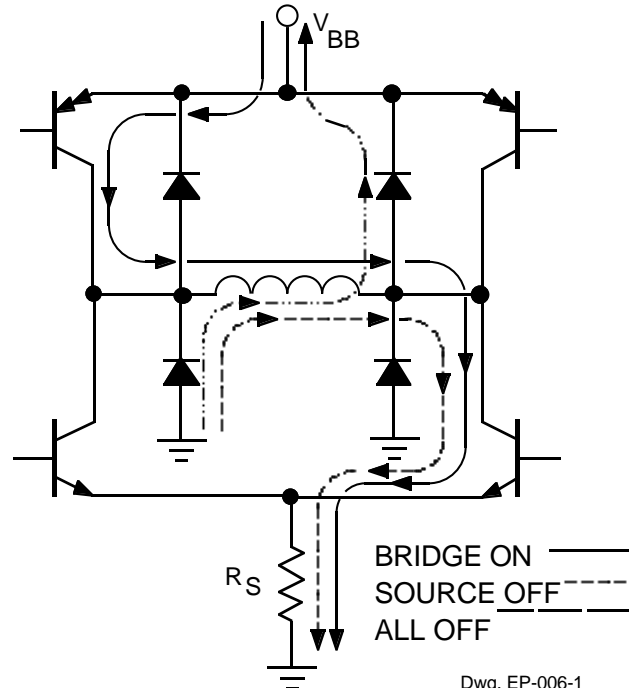

Dwg. EP-006-1

2917 DUAL FULL-BRIDGE PWM MOTOR DRIVER

CURRENT-CONTROL TRUTH TABLE

| I_0 | I_1 | Output Current |
|-------|-------|---------------------------------|
| L | L | $V_{REF}/10 R_S = I_{TRIP}$ |
| H | L | $V_{REF}/15 R_S = 2/3 I_{TRIP}$ |
| L | H | $V_{REF}/30 R_S = 1/3 I_{TRIP}$ |
| H | H | 0 |

Loads with high distributed capacitances may result in high turn-on current peaks. This peak (appearing across R_S) will attempt to trip the comparator, resulting in erroneous current control or high-frequency oscillations. An external $R_C C_C$ low-pass filter may be needed to delay the action of the comparator.

LOGIC CONTROL OF OUTPUT CURRENT

Two logic level inputs (I_0 and I_1) allow digital selection of the motor winding current at 100%, 67%, 33%, or 0% of the maximum level per the table. The 0% output current condition turns off all drivers in the bridge and can be used as an output enable function. These logic level inputs greatly enhance the implementation of μP -controlled drive formats.

During half-step operations, the I_0 and I_1 inputs allow the μP to control the motor at a constant torque between all positions in an eight-step sequence. This is accomplished by digitally selecting 100% drive current when only one phase is on and 67% drive current when two phases are on.

The logic control inputs can also be used to select a reduced current level (and reduced power dissipation) for 'hold' conditions and/or increased current (and available torque) for start-up conditions.

GENERAL

To avoid excessive voltage spikes on the LOAD SUPPLY pin (V_{BB}), a large-value capacitor ($\geq 47 \mu F$) should be connected from V_{BB} to ground as close as possible to the device. Under no circumstances should the voltage at LOAD SUPPLY exceed 45 V.

The PHASE input to each bridge determines the direction motor winding current flows. An internally generated deadtime (approximately 3 μs) prevents crossover currents that can occur when switching the PHASE input.

All four drivers in the bridge output can be turned off ($V_{EN} \geq 2.4 V$ or $I_0 = I_1 \geq 2.4 V$), resulting in a fast current decay through the internal output clamp and flyback diodes. The fast current decay is desirable in half-step and high-speed applications. All logic inputs float high; the ENABLE input must be tied low if it is not used.

Varying the reference voltage (V_{REF}) provides continuous control of the peak load current for micro-stepping applications, within the specified limits for V_{REF} .

Thermal protection circuitry turns off all drivers when the junction temperature reaches $+170^\circ C$. It is only intended to protect the device from failures due to excessive junction temperature and should not imply that output short circuits are permitted. The output drivers are re-enabled when the junction temperature cools to $+145^\circ C$.

2917 DUAL FULL-BRIDGE PWM MOTOR DRIVER

UDN2917EB

Dimensions in Inches
(controlling dimensions)

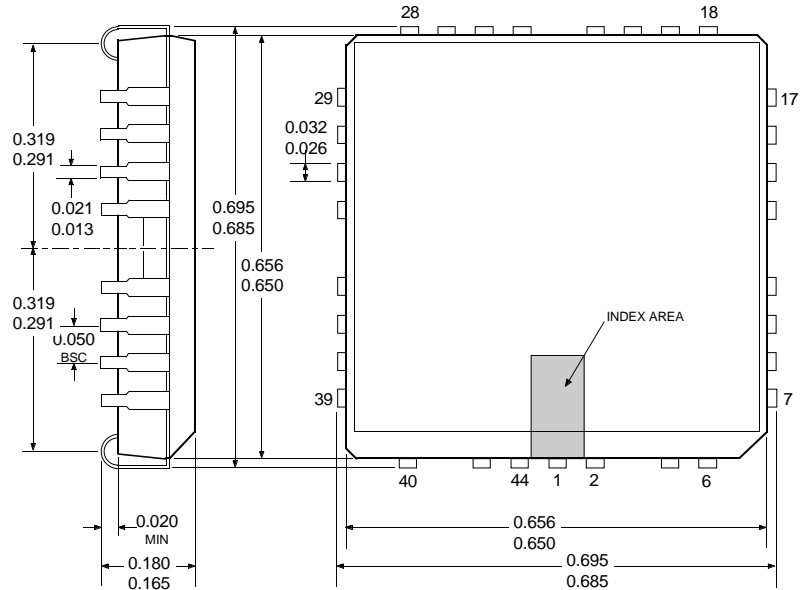

Dwg. MA-005-44A in

Dimensions in Millimeters
(for reference only)

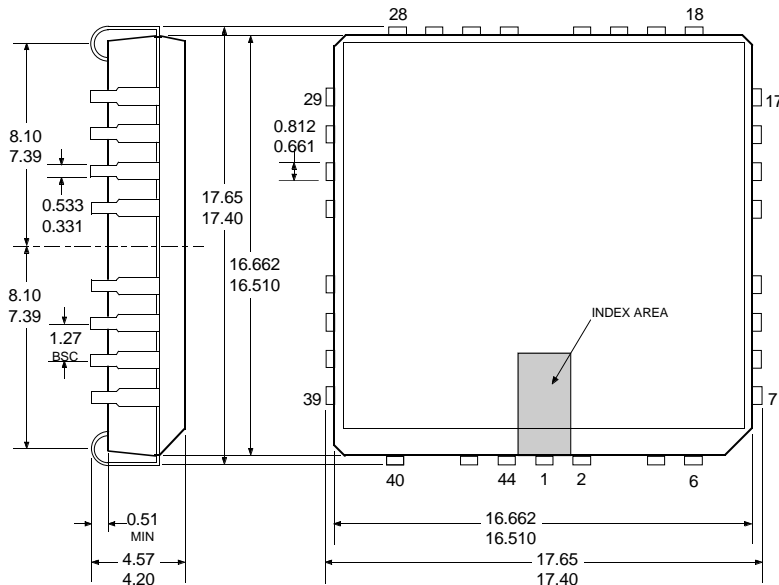

Dwg. MA-005-44A mm

- NOTES: 1. MO-047AC except for terminal shoulder height.
 2. Webbed lead frame. Leads 7-17 and 29-39 are internally one piece.
 3. Lead spacing tolerance is non-cumulative.
 4. Exact body and lead configuration at vendor's option within limits shown.
 5. Supplied in standard sticks/tubes of 27 devices or add "TR" to part number for tape and reel.



115 Northeast Cutoff, Box 15036
 Worcester, Massachusetts 01615-0036 (508) 853-5000

2917
DUAL FULL-BRIDGE
PWM MOTOR DRIVER

The products described here are manufactured under one or more U.S. patents or U.S. patents pending.

Allegro MicroSystems, Inc. reserves the right to make, from time to time, such departures from the detail specifications as may be required to permit improvements in the performance, reliability, or manufacturability of its products. Before placing an order, the user is cautioned to verify that the information being relied upon is current.

Allegro products are not authorized for use as critical components in life-support devices or systems without express written approval.

The information included herein is believed to be accurate and reliable. However, Allegro MicroSystems, Inc. assumes no responsibility for its use; nor for any infringement of patents or other rights of third parties which may result from its use.