

2981 THRU 2984 8-CHANNEL SOURCE DRIVERS

One of Eight Drivers

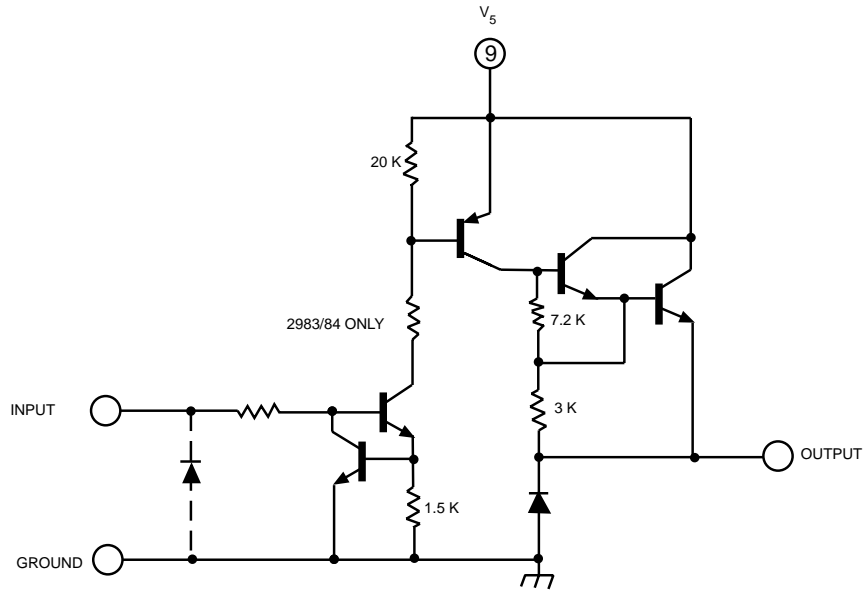

Dwg. No. A-10,242B

A2982SLW and A2984SLW

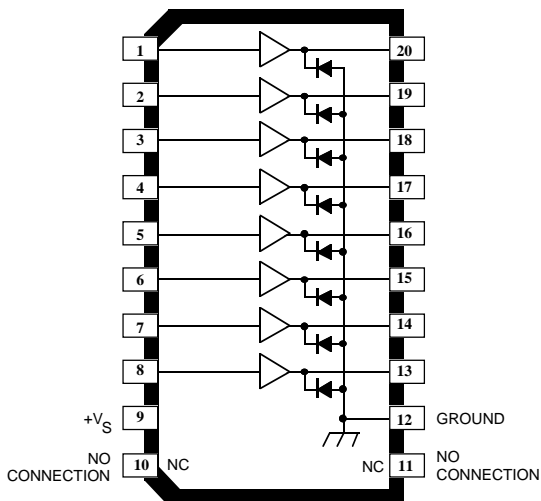

Dwg. PP-064-2

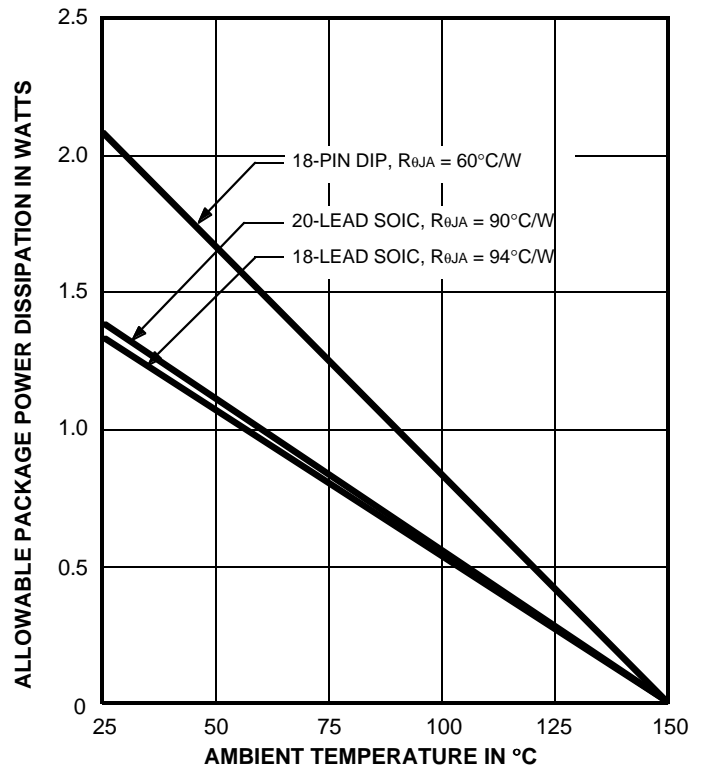

Dwg. GP-022-4A

2981 THRU 2984 8-CHANNEL SOURCE DRIVERS

ELECTRICAL CHARACTERISTICS at $T_A = +25^\circ\text{C}$ (unless otherwise specified).

Characteristic	Symbol	Applicable Devices	Test Conditions	Test Fig.	Limits			
					Min.	Typ.	Max.	Units
Output Leakage Current	I_{CEX}	2981/82†	$V_{IN} = 0.4\text{ V}^*$, $V_S = 50\text{ V}$, $T_A = +70^\circ\text{C}$	1	—	—	200	μA
		2983/84†	$V_{IN} = 0.4\text{ V}^*$, $V_S = 80\text{ V}$, $T_A = +70^\circ\text{C}$	1	—	—	200	μA
Output Sustaining Voltage	$V_{CE(SUS)}$	2981/82†	$I_{OUT} = -45\text{ mA}$	—	35	—	—	V
		2983/84†	$I_{OUT} = -70\text{ mA}$	—	45	—	—	V
Collector-Emitter Saturation Voltage	$V_{CE(SAT)}$	All	$V_{IN} = 2.4\text{ V}$, $I_{OUT} = -100\text{ mA}$	2	—	1.6	1.8	V
			$V_{IN} = 2.4\text{ V}$, $I_{OUT} = -225\text{ mA}$	2	—	1.7	1.9	V
			$V_{IN} = 2.4\text{ V}$, $I_{OUT} = -350\text{ mA}$	2	—	1.8	2.0	V
Input Current	$I_{IN(ON)}$	2981/83A	$V_{IN} = 2.4\text{ V}$	3	—	140	200	μA
			$V_{IN} = 3.85\text{ V}$	3	—	310	450	μA
		2982/84†	$V_{IN} = 2.4\text{ V}$	3	—	140	200	μA
			$V_{IN} = 12\text{ V}$	3	—	1.25	1.93	mA
Output Source Current (Outputs Open)	I_{OUT}	2981/83A	$V_{IN} = 2.4\text{ V}$, $V_{CE} = 2.0\text{ V}$	2	-350	—	—	mA
		2982/84†	$V_{IN} = 2.4\text{ V}$, $V_{CE} = 2.0\text{ V}$	2	-350	—	—	mA
Supply Current Leakage Current	I_S	2981/82†	$V_{IN} = 2.4\text{ V}^*$, $V_S = 50\text{ V}$	4	—	—	10	mA
		2983/84†	$V_{IN} = 2.4\text{ V}^*$, $V_S = 80\text{ V}$	4	—	—	10	mA
Clamp Diode Forward Voltage	I_R	2981/82†	$V_R = 50\text{ V}$, $V_{IN} = 0.4\text{ V}^*$	5	—	—	50	μA
		2983/84†	$V_R = 80\text{ V}$, $V_{IN} = 0.4\text{ V}^*$	5	—	—	50	μA
Clamp Diode	V_F	All	$I_F = 350\text{ mA}$	6	—	1.5	2.0	V
Turn-On Delay	t_{ON}	All	$0.5 E_{IN}$ to $0.5 E_{OUT}$, $R_L = 100\Omega$, $V_S = 35\text{ V}$	—	—	1.0	2.0	μs
Turn-Off Delay	t_{OFF}	All	$0.5 E_{IN}$ to $0.5 E_{OUT}$, $R_L = 100\Omega$, $V_S = 35\text{ V}$, See Note	—	—	5.0	10	μs

NOTES: Turn-off delay is influenced by load conditions. Systems applications well below the specified output loading may require timing considerations for some designs, i.e., multiplexed displays or when used in combination with sink drivers in a totem pole configuration.

Negative current is defined as coming out of (sourcing) the specified device terminal.

* All inputs simultaneously.

† Complete part number includes a prefix (A or UDN) and a suffix (A or SLW) as follows:

UDN2981A,
UDN2982A, UDN2982LW, or A2982SLW,
UDN2983A,
UDN2984A, UDN2984LW, or A2984SLW.

**The A2984SLW, UDN2984A, & UDN2984LW are discontinued.
Shown for reference only.**

2981 THRU 2984 8-CHANNEL SOURCE DRIVERS

TEST FIGURES

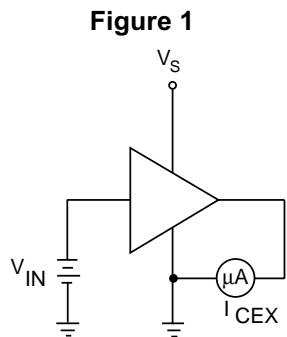

Dwg. No. A-11,083

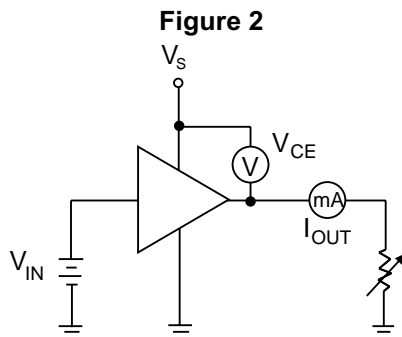

Dwg. No. A-11,084

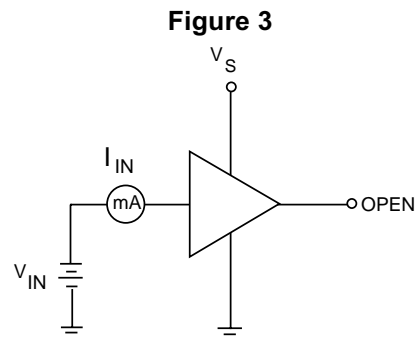

Dwg. No. A-11,085

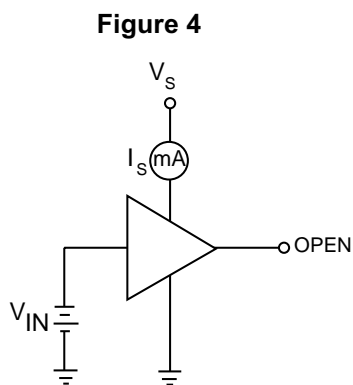

Dwg. No. A-11,086

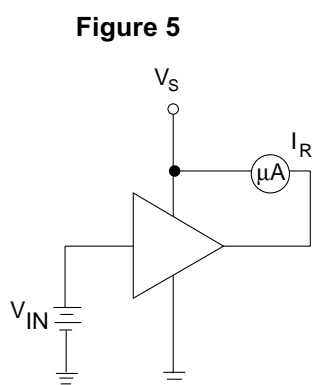

Dwg. No. A-11,087

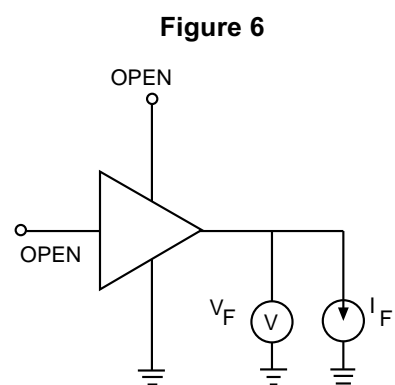

Dwg. No. A-11,088

2981 THRU 2984 8-CHANNEL SOURCE DRIVERS

Allowable peak collector current as a function of duty cycle

Series UDN2980A

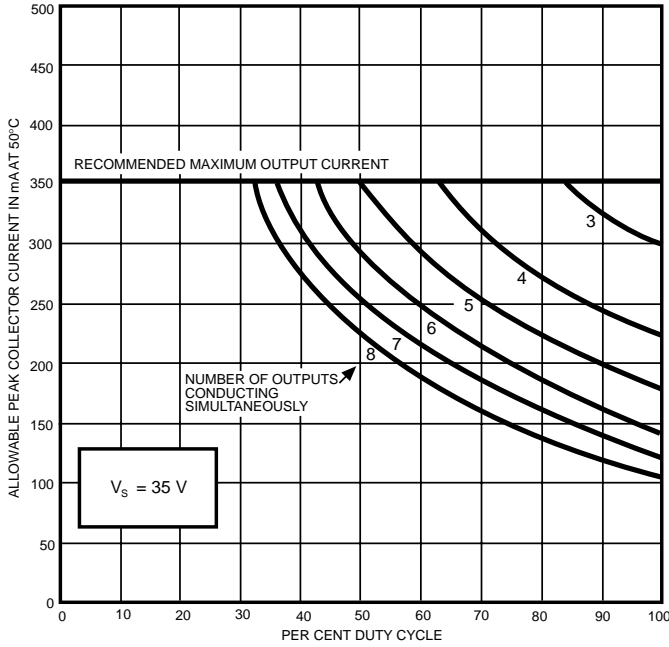

Dwg. No. A-11,106B

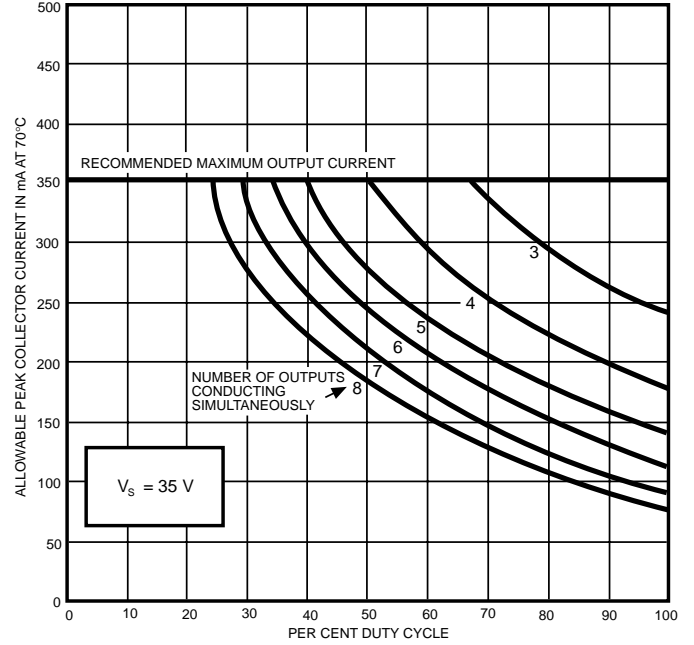

Dwg. No. A-11,111B

UDN2981A and UDN2982A

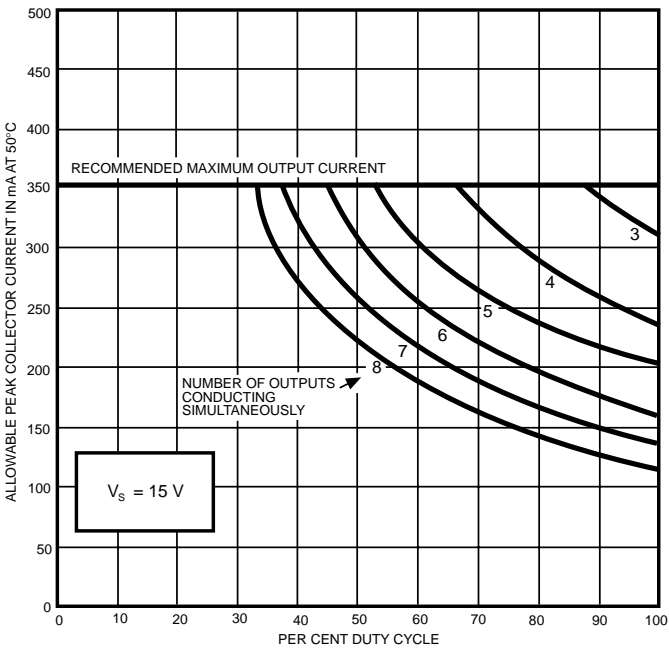

Dwg. No. A-11,107B

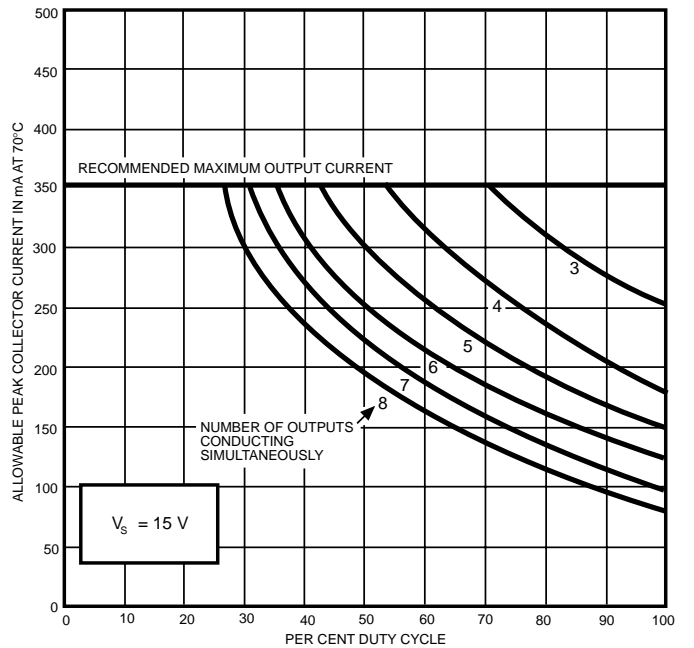

Dwg. No. A-11,108B

2981 THRU 2984 8-CHANNEL SOURCE DRIVERS

Allowable peak collector current as a function of duty cycle

UDN2983A and UDN2984A

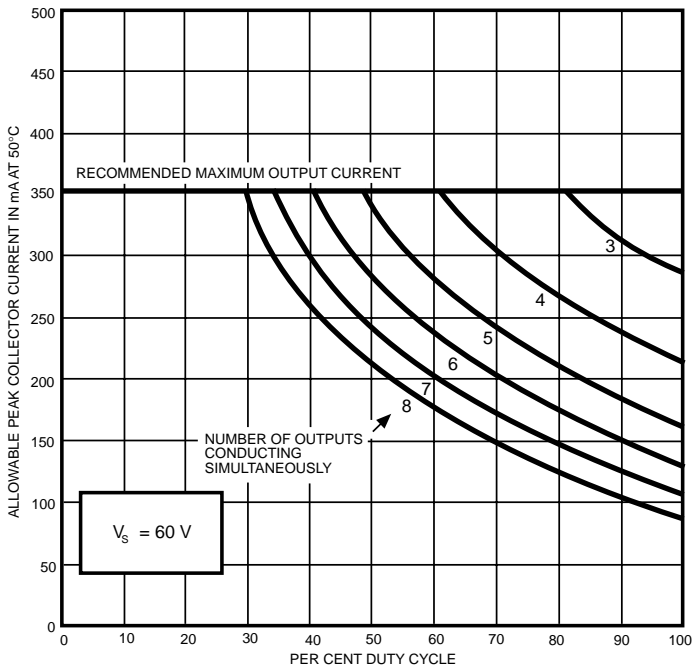

Dwg. No. A-11,109B

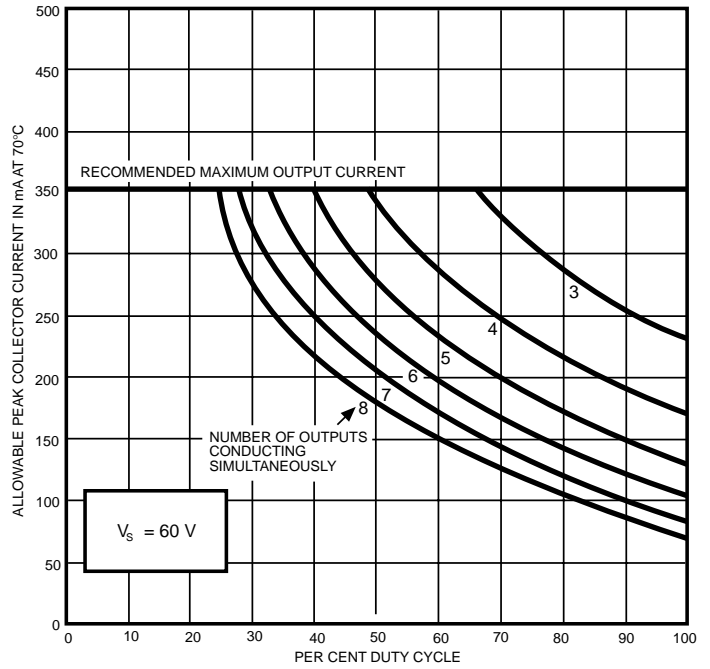

Dwg. No. A-11,110B

Input current as a function of input voltage

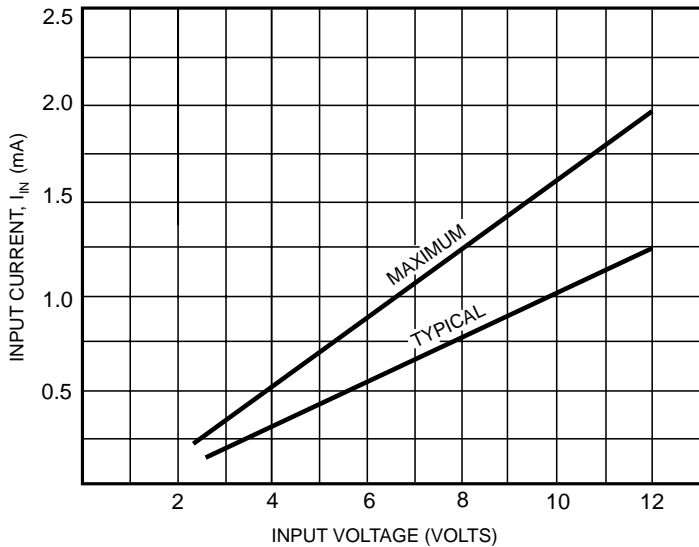

Dwg. No. A-11,115B

Typical electroensitive printer application

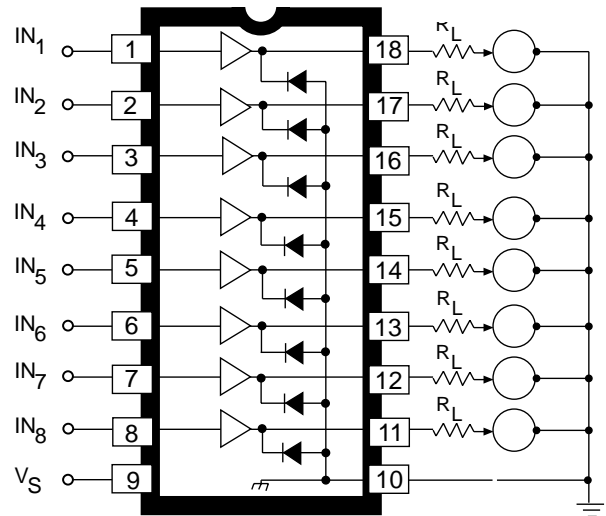

Dwg. No. A-11,113A

2981 THRU 2984 8-CHANNEL SOURCE DRIVERS

UDN2981A, UDN2982A, UDN2983A, and UDN2984A

Dimensions in Inches (controlling dimensions)

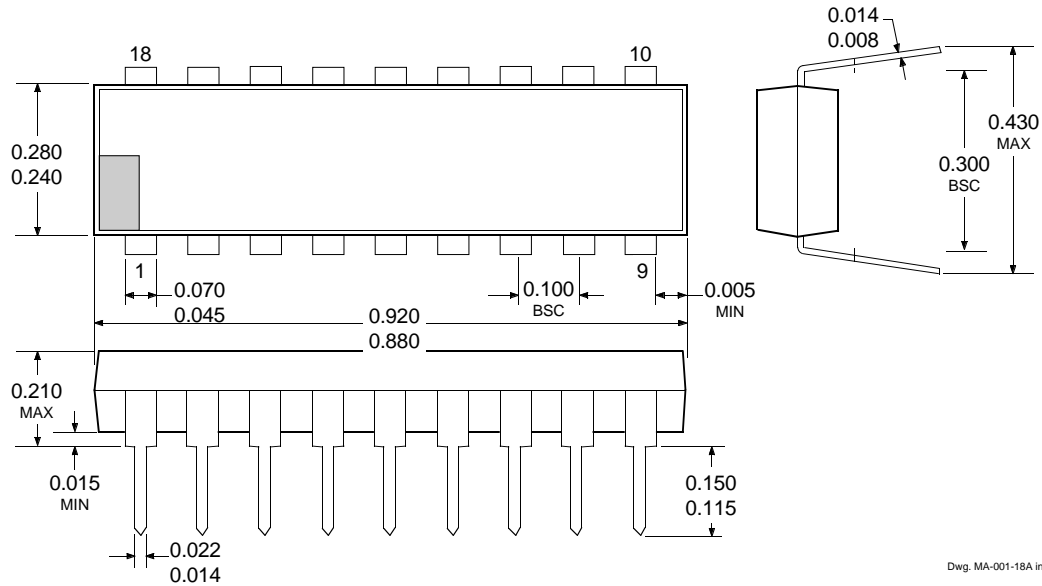

Dimensions in Millimeters (for reference only)

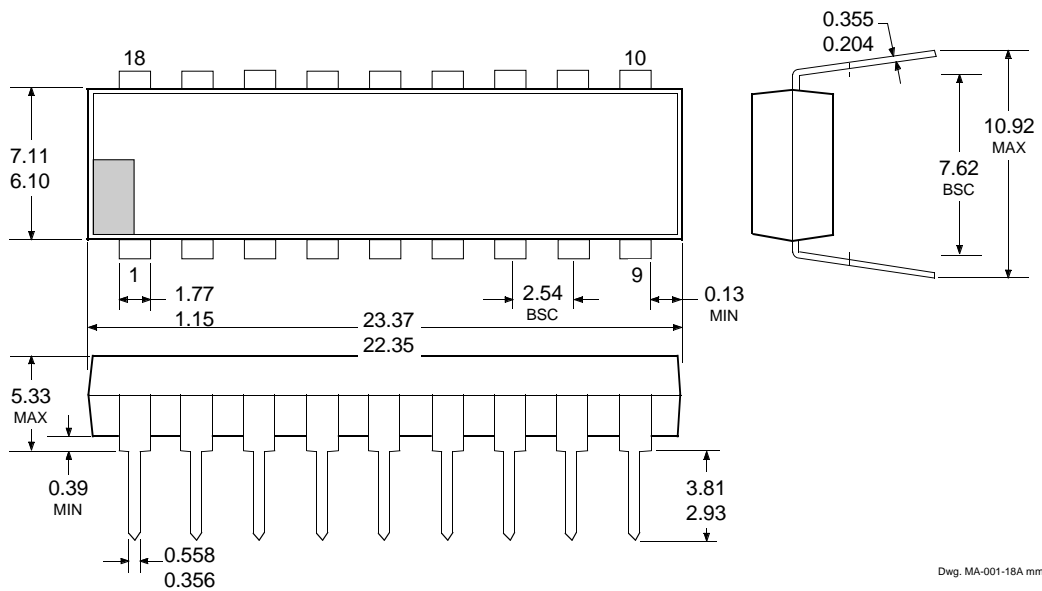

- NOTES: 1. Exact body and lead configuration at vendor's option within limits shown.
 2. Lead spacing tolerance is non-cumulative.
 3. Lead thickness is measured at seating plane or below.
 4. Supplied in standard sticks/tubes of 21 devices.

2981 THRU 2984 8-CHANNEL SOURCE DRIVERS

UDN2982LW and UDN2984LW (add "TR" to part number for tape and reel) Dimensions in Inches (for reference only)

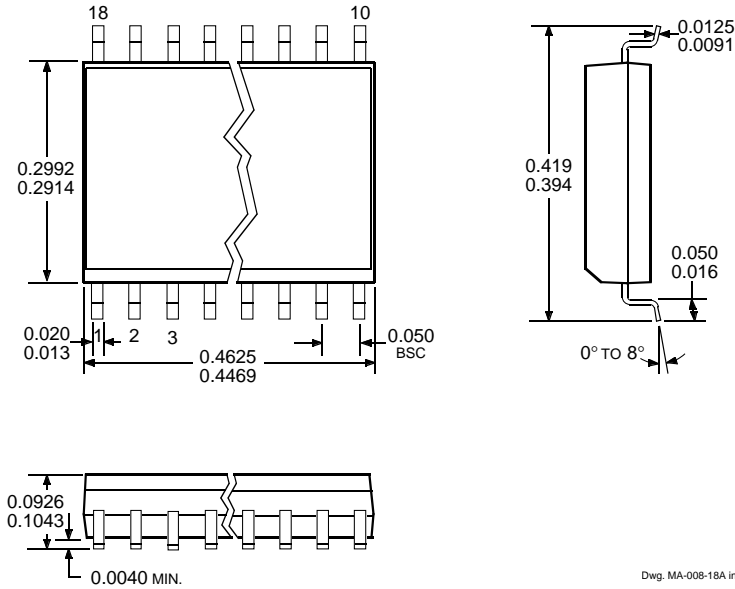

Dimensions in Millimeters (controlling dimensions)

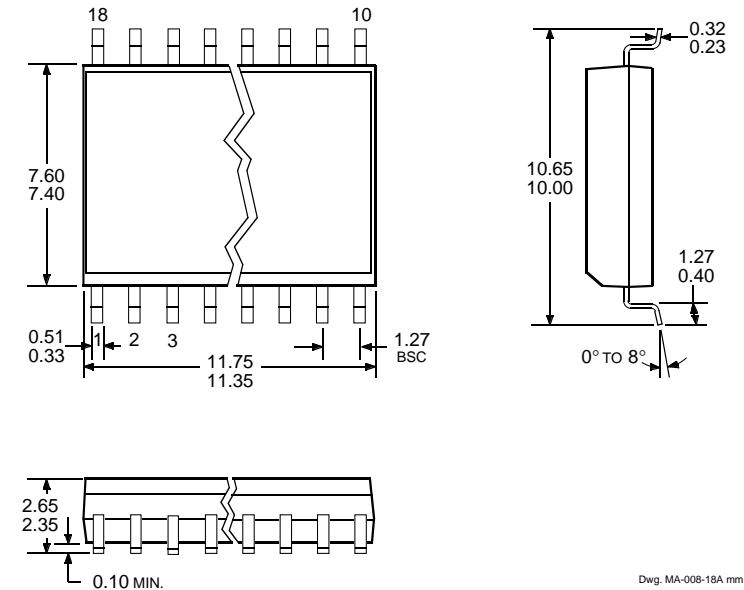

- NOTES: 1. Exact body and lead configuration at vendor's option within limits shown.
2. Lead spacing tolerance is non-cumulative.
3. Supplied in standard sticks/tubes of 41 devices or add "TR" to part number for tape and reel.

2981 THRU 2984 8-CHANNEL SOURCE DRIVERS

A2982SLW and A2984SLW (add "TR" to part number for tape and reel) Dimensions in Inches (for reference only)

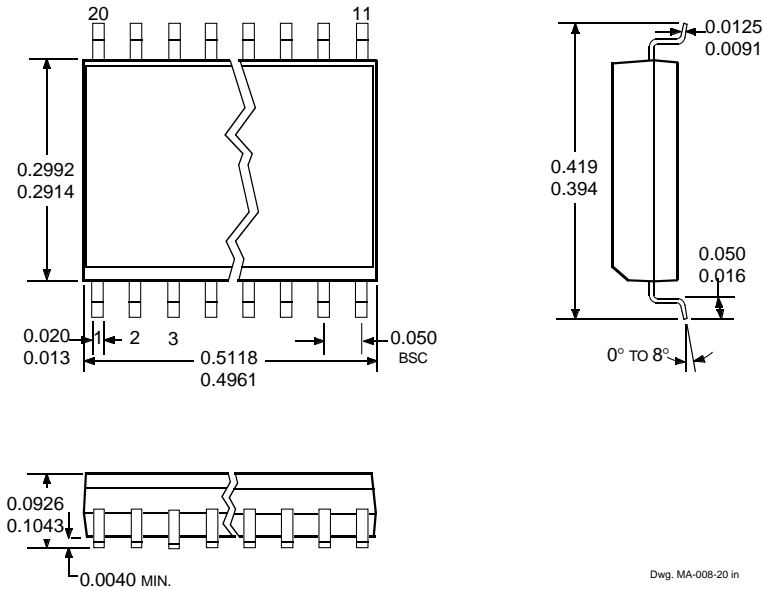

Dimensions in Millimeters (controlling dimensions)

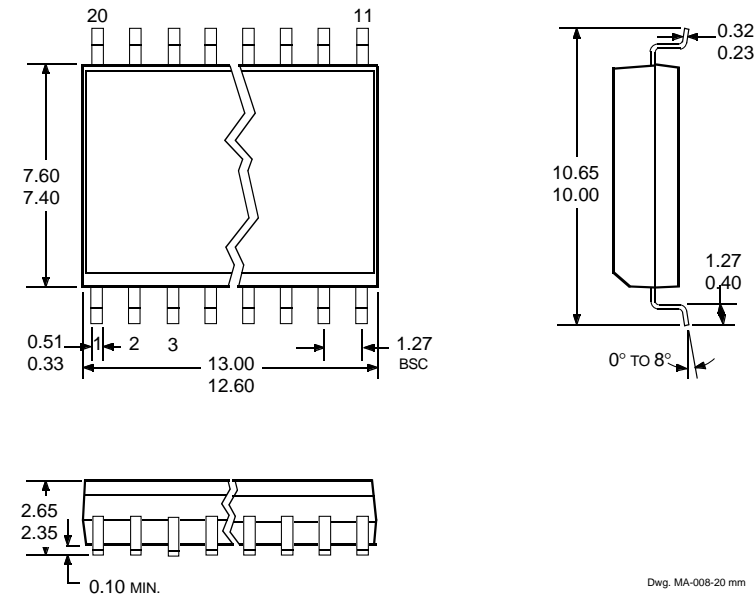

- NOTES: 1. Exact body and lead configuration at vendor's option within limits shown.
2. Lead spacing tolerance is non-cumulative.
3. Supplied in standard sticks/tubes of 37 devices or add "TR" to part number for tape and reel.

2981 THRU 2984
8-CHANNEL
SOURCE DRIVERS

The products described here are manufactured under one or more U.S. patents or U.S. patents pending.

Allegro MicroSystems, Inc. reserves the right to make, from time to time, such departures from the detail specifications as may be required to permit improvements in the performance, reliability, or manufacturability of its products. Before placing an order, the user is cautioned to verify that the information being relied upon is current.

Allegro products are not authorized for use as critical components in life-support devices or systems without express written approval.

The information included herein is believed to be accurate and reliable. However, Allegro MicroSystems, Inc. assumes no responsibility for its use; nor for any infringement of patents or other rights of third parties which may result from its use.