

# Z16C01/C02

## CPU CENTRAL PROCESSING UNIT

### FEATURES

Part	Memory Address	Memory Extension	Speed (MHz)
Z16C01	8 Mbytes	48 Mbytes	10
Z16C02	64 Kbytes	384 Kbytes	10

- 40/48-Pin PDIP and 44-Pin PLCC Packages
- $+4.5 \leq V_{CC} \leq +5.5$ -Volt Operating Range
- Low-Power CMOS
- 0°C to +70°C Temperature Range

- Extendable Register Files
- Nine Basic Instruction Types
- Eight User-Selectable Addressing Modes
- Seven Data Types
- Supports Three Interrupt Types and Four Traps
- RISC-Like Load/Store Architecture

### GENERAL DESCRIPTION

The Z16C01/C02 CPU are members of the 16-bit processor and controller family. Designed using a RISC-like Load/Store architecture, the CPU can operate in either system or normal modes, permitting privileged operations and improving operating system organization and implementation.

To boost the main CPU's performance capability, the processor core includes hardwired control and is a 16-bit real-time processor functioning at register access speeds. Register flexibility is created by grouping or overlapping multiple registers, and by allowing extended register file capabilities as the system expands. Easy extended register file control is accomplished through a single instruction stream communication.

The CPU supports three types of interrupts (non-maskable, vectored, and non-vectored) and four traps (system call, extended process architecture instruction, privileged instructions, and segmentation trap). The vectored and non-vectored interrupts are maskable.

The processor's resources include seven data types that range from bits to 32-bit long words, and byte and word strings, plus eight user-selectable addressing modes. The nine basic instruction types can be combined with various data types and addressing modes to form a powerful set of 414 instructions.

The extended processing architecture features provide a modular approach to expanding both the hardware and software capabilities of the Z16C01/C02.

**Notes:**

All Signals with a preceding front slash, "/", are active Low, e.g.: B/W (WORD is active Low); /B/W (BYTE is active Low, only).

Power connections follow conventional descriptions below:

Connection	Circuit	Device
Power Ground	$V_{CC}$ GND	$V_{DD}$ $V_{SS}$

GENERAL DESCRIPTION (Continued)

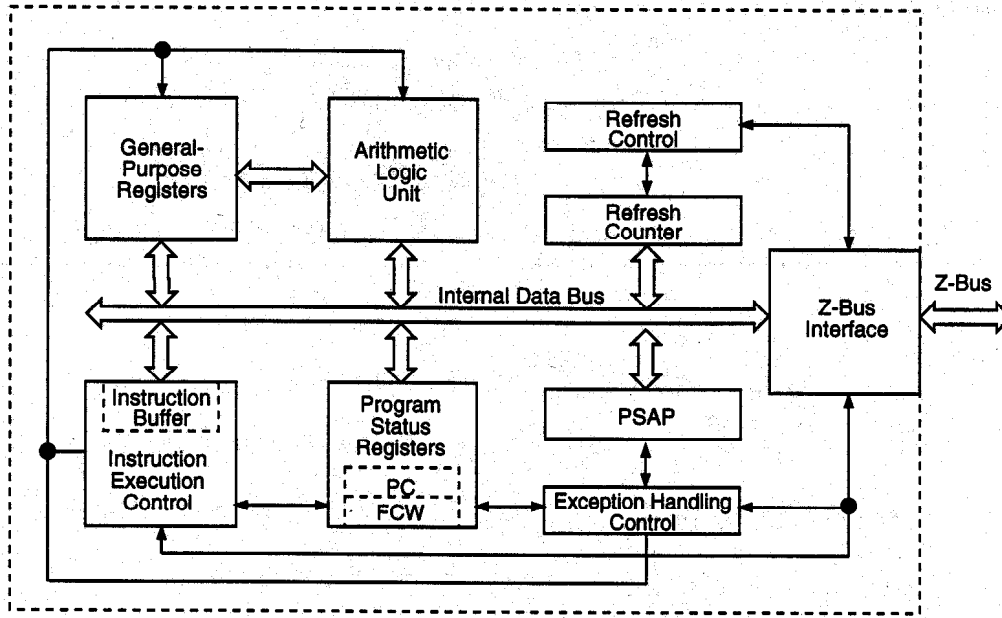

Z16C00 CPU Functional Block Diagram

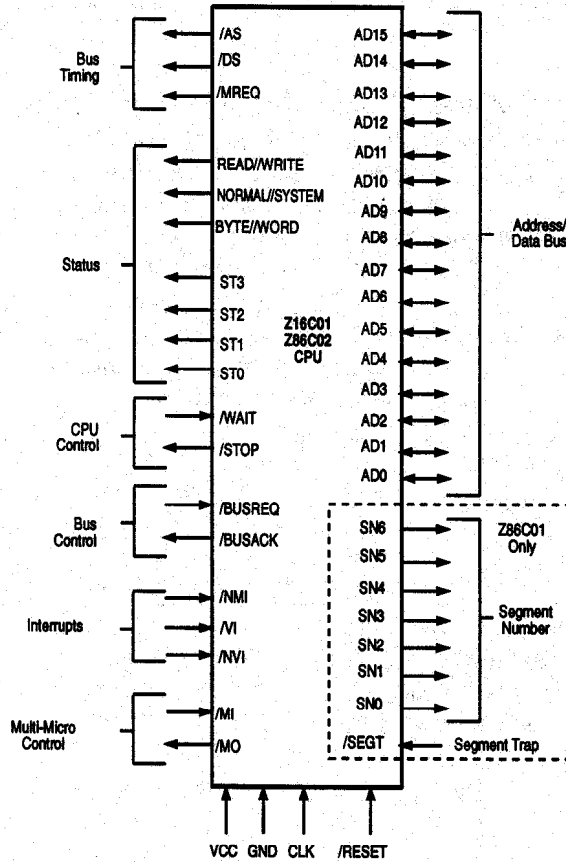

Z16C01/C02 Signal Descriptions

### PIN DESCRIPTION

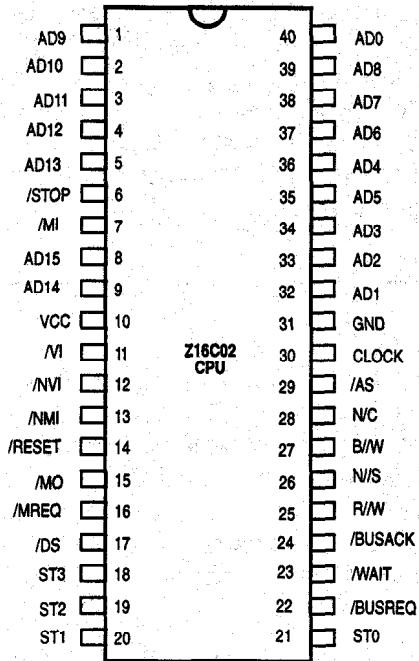

Z16C02 40-Pin PDIP

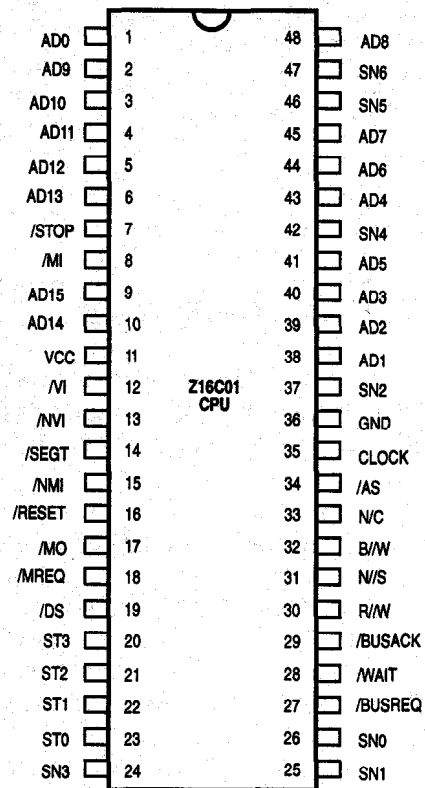

Z16C01 48-Pin PDIP

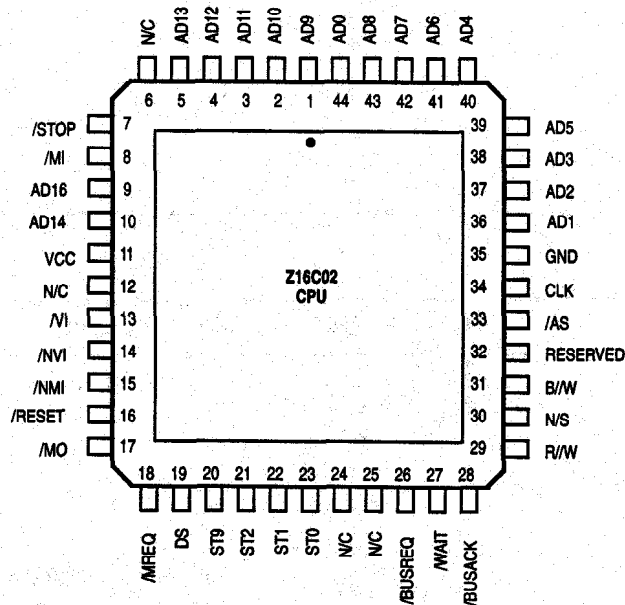

Z16C02 44-Pin PLCC

### ABSOLUTE MAXIMUM RATINGS

Voltages on  $V_{CC}$  with respect to  $V_{SS}$ .....-0.3V to +7.0V  
 Voltages on all inputs with respect to  $V_{SS}$ .....-0.3V to  $V_{CC}+0.3V$   
 Storage Temperature.....-65°C to +150°C

Stresses greater than those listed under Absolute Maximum Ratings may cause permanent damage to the device. This is a stress rating only; operating of the device at any condition above these indicated in the operational sections of these specifications is not implied. Exposure to absolute maximum rating conditions for extended periods may affect device reliability.

### STANDARD TEST CONDITIONS

The DC characteristics below apply for the following test conditions, unless otherwise noted. All voltages are referenced to GND (0V). Positive current flows into the referenced pin.

Available operating temperature ranges are:

- S = 0°C to +70°C, + 4.5V ≤  $V_{CC}$  ≤ + 5.5V (Z16C01, Z16C02)
- E = -40°C to +100°C, + 4.5V ≤  $V_{CC}$  ≤ + 5.5V (Z16C01, Z16C02)

All AC parameters assume a total load capacitance (including parasitic capacitances) or 100 pf max, except for parameter 6 (50 pf max). Timing reference between two output signals assume a load difference of 50 pf max.

The Ordering Information section lists package temperature ranges and product numbers.

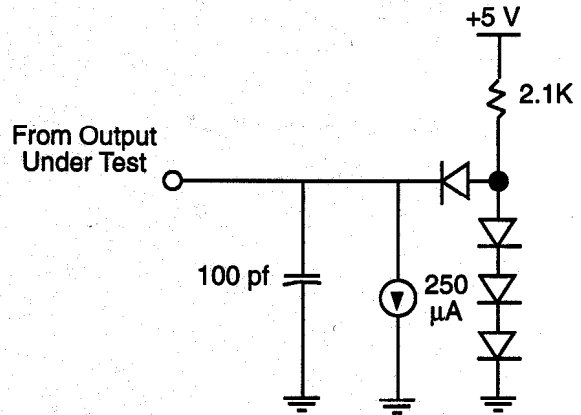

Test Load Diagram

### DC CHARACTERISTICS

Sym	Parameter	MIN	MAX	Units	Condition
$V_{CH}$	Clock Input High Voltage	$V_{CC}-0.4$	$V_{CC}+0.3$	V	Driven by External Clock Generator
$V_{CL}$	Clock Input Low Voltage	-0.3	0.45	V	Driven by External Clock Generator
$V_{IH}$	Input High Voltage	2.0	$V_{CC}+0.3$	V	
$V_{IH}$ RESET	Input High Voltage on /RESET Pin	2.4	$V_{CC}+0.3$	V	
$V_{IH}$ NMI	Input High Voltage on NMI Pin	2.4	$V_{CC}+0.3$	V	
$V_{IL}$	Input Low Voltage	-0.3	0.8	V	
$V_{OH}$	Output High Voltage	2.4		V	$I_{OH} = -250\mu A$
$V_{OL}$	Output Low Voltage		0.4	V	$I_{OL} = +2.0mA$
$I_{IL}$	Input Leakage		±10	μA	$0.4V \leq V_{IN} \leq +2.4V$
$I_{IL}$ SEGT	Input Leakage on /SEGT Pin	-100	100	μA	
$I_{OL}$	Output Leakage		±10	μA	$0.4V \leq V_{IN} \leq +2.4V$
$I_{CC}$	$V_{CC}$ Power Supply Current		35	mA	10MHz

**FOOTNOTES TO AC CHARACTERISTICS**

No.	Symbol	Z16C01/2 10 MHz Equation
11	TdA(DR)	2TcC+TwCh-60ns
13	TdDS(A)	TwCl+5ns
16	TdDW(DS)	TcC+TwCh-30ns
17	TdA(MR)	TwCh-20ns
19	TwMRh	TcC-20ns
20	TdMR(A)	TwCl-20ns
21	TdDW(DSW)	TwCh-25ns
22	TdMR(DR)	2TcC-60ns
25	TdA(AS)	TwCh-20ns
27	TdAS(DR)	2TcC-60ns
28	TdDS(AS)	TwCl-20ns
29	TwAS	TwCh-5ns
30	TdAS(A)	TwCl-10ns
32	TdAS(DSR)	TwCl-5ns
33	TdDSR(DR)	TcC+TwCh-60ns
35	TdDS(DW)	TwCl-15ns
36	TdA(DSR)	TcC-35ns
38	TwDSR	TcC+TwCh-30ns
40	TwDSW	TcC-25ns
41	TdDSI(DR)	2TcC-80ns
43	TwDS	2TcC-40ns
44	TdAS(DSA)	4TcC+TwCl-30ns
46	TdDSA(DR)	2TcC+TwCh-75ns
48	TdS(AS)	TwCh-20ns
68	TwA	TcC-50ns
69	TdDS(s)	TwCl-10ns

**AC Timing Test Conditions:**

$$\begin{aligned}
 V_{OL} &= 0.8V \\
 V_{OH} &= 2.0V \\
 V_{IL} &= 0.8V \\
 V_{IH} &= 2.4V \\
 V_{ILC} &= 0.45V \\
 V_{IHC} &= V_{CC} - 0.4V
 \end{aligned}$$

**AC CHARACTERISTICS**

No.	Symbol	Parameter	Z16C01/2 10 MHz	
			Min	Max
1	TcC	Clock Cycle Time	100	**
2	TwCh	Clock Width (High)	40	**
3	TwCl	Clock Width (Low)	40	**
4	TfC	Clock Fall Time		10
5	TrC	Clock Rise Time		10
6	TdC(SNv)	Clock+ Segment Number Valid (50pf load)		50
7	TdC(SNn)	Clock +Segment Number Not Valid	0	
8	TdC(Bz)	Clock + Bus Float		50
9	TdC(A)	Clock +Address Valid		50
10	TdC(Az)	Clock + Address Float		50
11	TdA(DR)	Address Valid to Read Data Required Valid		180*
12	TsDR(C)	Read Data to Clock Fall Setup Time	20	
13	TdDS(A)	/DS+Address Active	45*	
14	TdC(DW)	Clock + Write Data Valid		60
15	ThDR(DS)	Read Data to /DS Rise Hold Time	0	
16	TdDW(DS)	Write Data Valid to /DS Rise Delay	110*	
17	TdA(MR)	Address Valid to /MREQ Fall Delay	20*	
18	TdC(MR)	Clock Fall to /MREQ Fall Delay		50
19	TwMRh	/MREQ Width (High)	80*	
20	TdMR(A)	/MREQ [ Address Not Active	20*	
21	TdDW(DSW)	Write Data Valid to /DS Fall (Write) Delay	15*	
22	TdMR(DR)	/MREQ [ Read Data Required Valid		140*
23	TdC(MR)	Clock Fall /MREQ Rise Delay		50
24	TdC(ASf)	Clock + /AS Fall Delay		35
25	TdA(AS)	Address Valid to /AS Rise Delay	20*	
26	TdC(ASr)	Clock [ /AS Rise Delay		25
27	TdAS(DR)	/AS + Read Data Required Valid		140*
28	TdDS(AS)	/DS + /AS Fall Delay	20*	
29	TwAS	/AS Width (Low)	35*	
30	TdAS(A)	/AS + Address Not Active Delay	30*	
31	TdAz(DSR)	Address Float to /DS (Read) Fall Delay	0	
32	TdAS(DSR)	/AS + /DS (Read) Fall Delay		35*
33	TdDSR(DR)	/DS (Read) Fall to Read Data Required Valid		80*
34	TdC(DSr)	Clock Fall to /DS Rise Delay		30
35	TdDS(DW)	/DS + Write Data Not Valid	25*	
36	TdA(DSR)	Address Valid to /DS (Read) Fall Delay	65*	
37	TdC(DSR)	Clock Rise /DS (Read) Fall Delay		45
38	TwDSR	/DS (Read) Width (Low)	110*	
39	TdC(DSW)	Clock Fall to /DS (Write) Fall Delay		45
40	TwDSW	/DS (Write) Width (Low)	75*	
41	TdDSI(DR)	/DS (I/O) [ Read Data Required Valid		120*
42	TdC(DSf)	Clock [ /DS (I/O) Fall Delay		45
43	TwDS	/DS (I/O) Width (Low)	160*	
44	TdAS(DSA)	/AS + /DS (Acknowledge) Fall Delay	410*	
45	TdC(DSA)	Clock + /DS (Acknowledge) Fall Delay		45
46	TdDSA(DR)	/DS (Acknowledge) [ Read Data Required Delay		165*
47	TdC(S)	Clock Rise to Status Valid Delay		50

**AC CHARACTERISTICS (Continued)**

No.	Symbol	Parameter	Z16C01/2	
			10 MHz Min	Max
48	TdS(AS)	Status Valid to /AS Rise Delay	20*	
49	TsR(C)	/RESET to Clock Rise Setup Time	35	
50	ThR(C)	/RESET to Clock Rise Hold Time	0	
51	TwNMI	/NMI Width (Low)	35	
52	TsNMI(C)	/NMI to Clock Rise Setup Time	35	
53	TsVI(C)	/VI, /NVI to Clock Rise Setup Time	35	
54	ThVI(C)	/VI, /NVI to Clock Rise Hold Time	10	
55	TsSGT(C)	/SEGT to Clock Rise Setup Time	35	
56	ThSGT(C)	/SEGT to Clock Rise Hold Time	10	
57	TsMI(C)	/MI to Clock Rise Setup Time	35	
58	ThMI(C)	/MI to Clock Rise Hold Time	0	
59	TdC(MO)	Clock Rise to /MO Delay		50
60	TsSTP(C)	/STOP to Clock Fall Setup Time	35	
61	ThSTP(C)	/STOP to Clock Fall Hold Time	0	
62	TsW(C)	/WAIT to Clock Fall Setup Time	20	
63	ThW(C)	/WAIT to Clock Fall Hold Time	5	
64	TsBRQ(C)	/BUSREQ to Clock Rise Setup Time	35	
65	ThBRQ(C)	/BUSREQ to Clock Rise Hold Time	5	
66	TdC(BAKr)	Clock Rise to /BUSACK Rise Delay		35
67	TdC(BAKf)	Clock Rise to /BUSACK Fall Delay		35
68	TwA	Address Valid Width	50*	
69	TdDS(S)	/DS Rise to STATUS Not Valid	30*	

\* Clock-cycle time-dependent characteristics. See Footnotes to AC Characteristics.

\*\* Clock may be stopped.

† Units in nanoseconds (ns).

COMPOSITE AC TIMING DIAGRAM

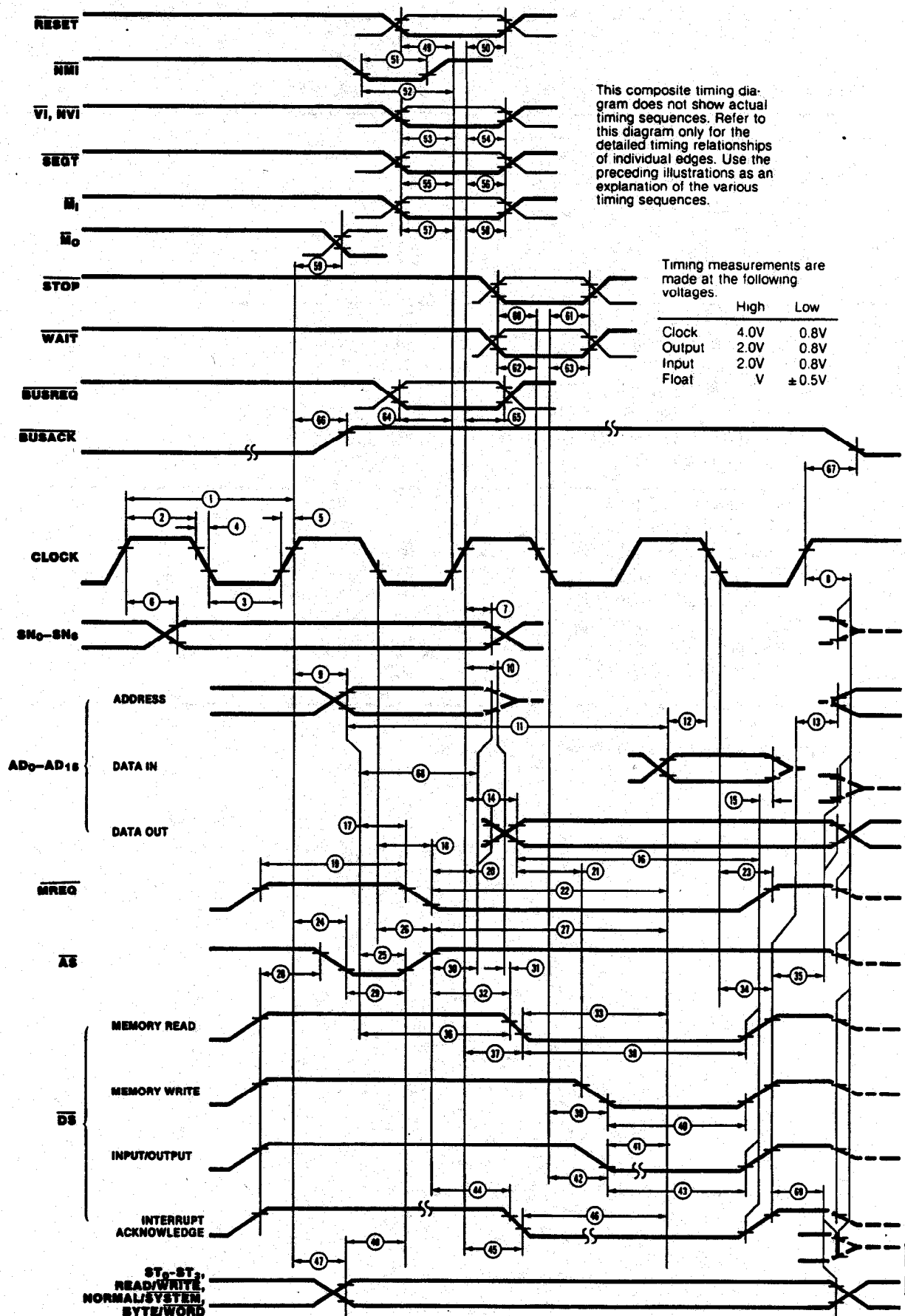

Composite AC Timing



TIMING DIAGRAMS

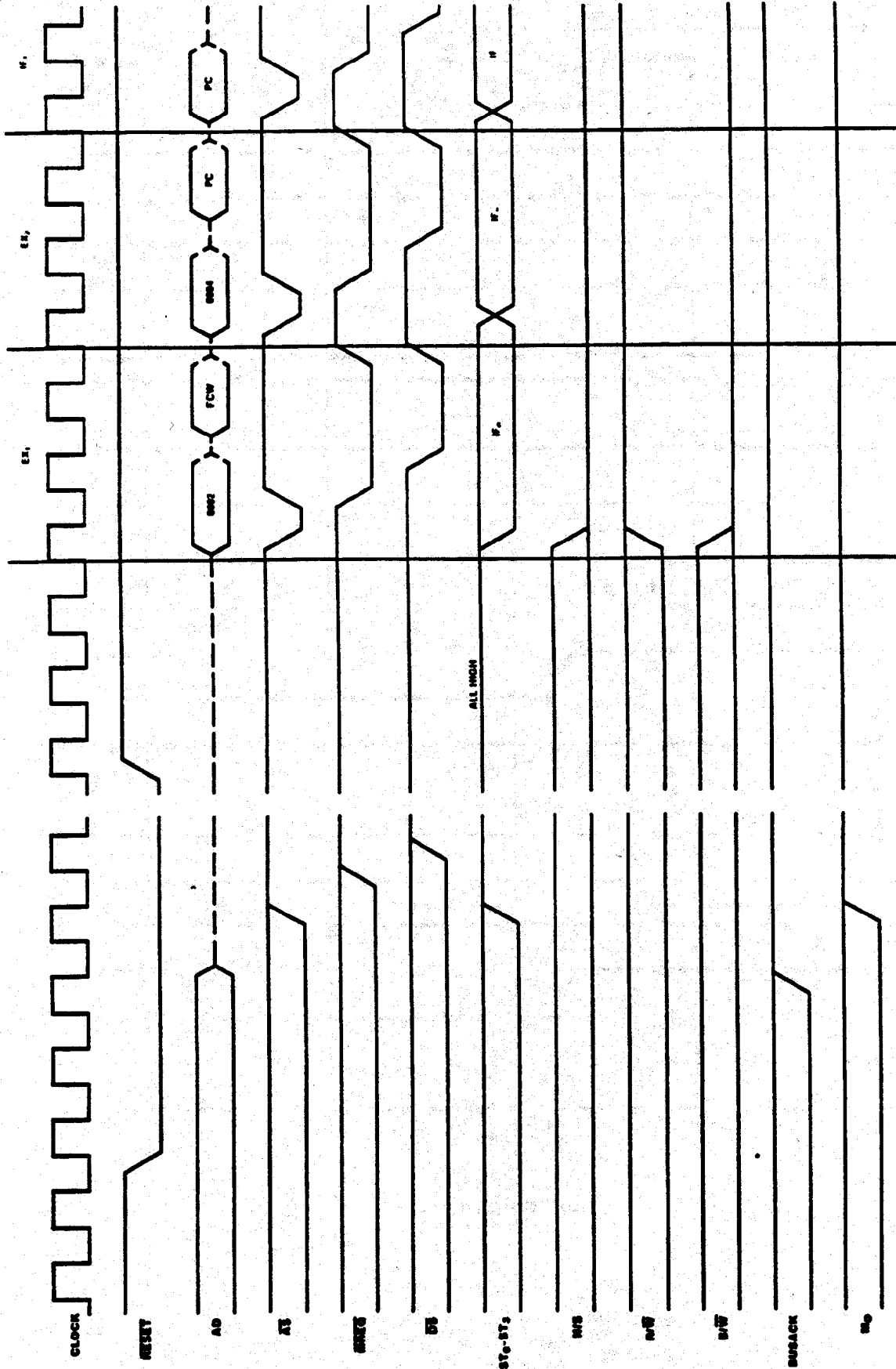

Reset Timing

TIMING DIAGRAMS (Continued)

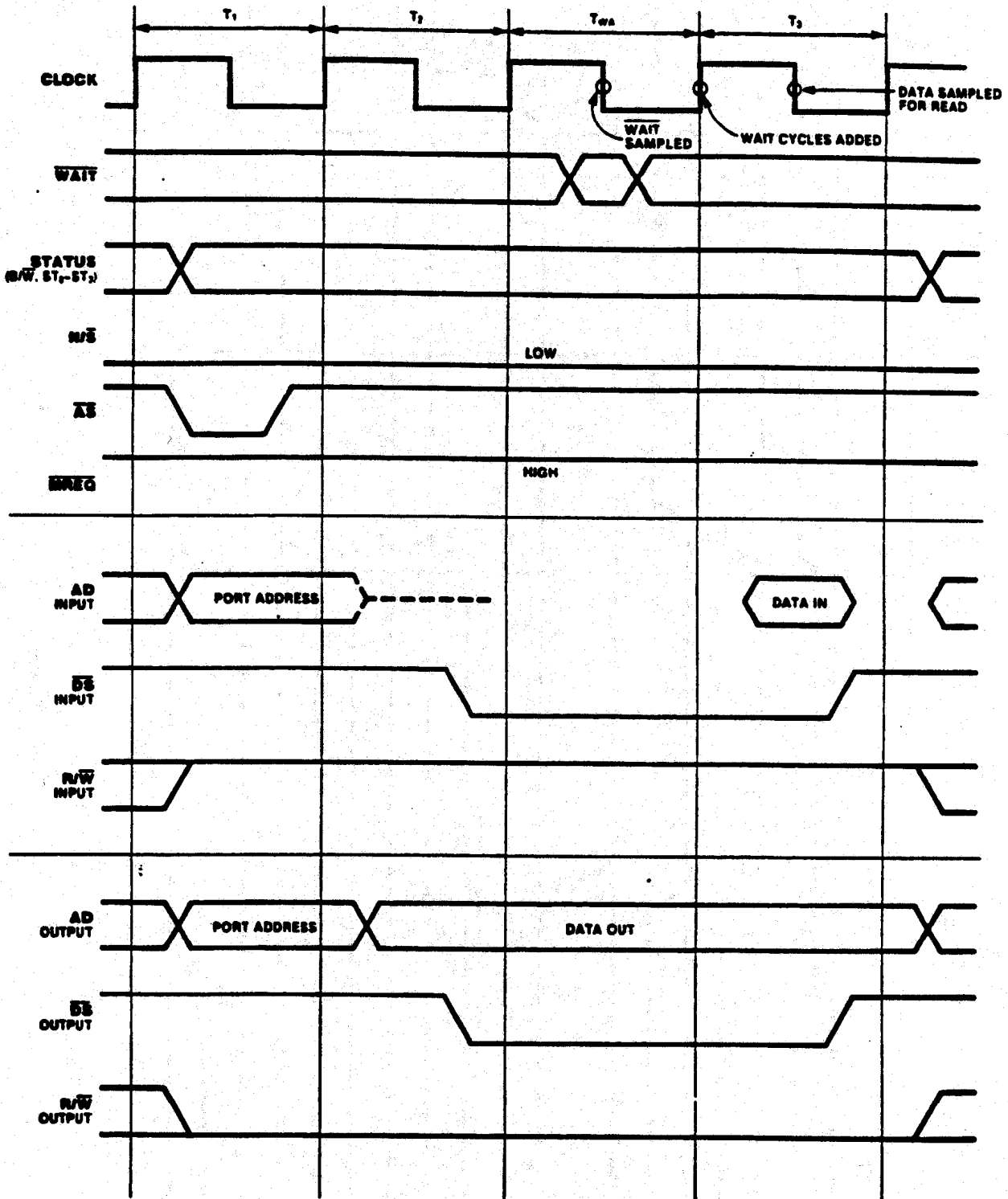

Input/Output Timing

TIMING DIAGRAMS (Continued)

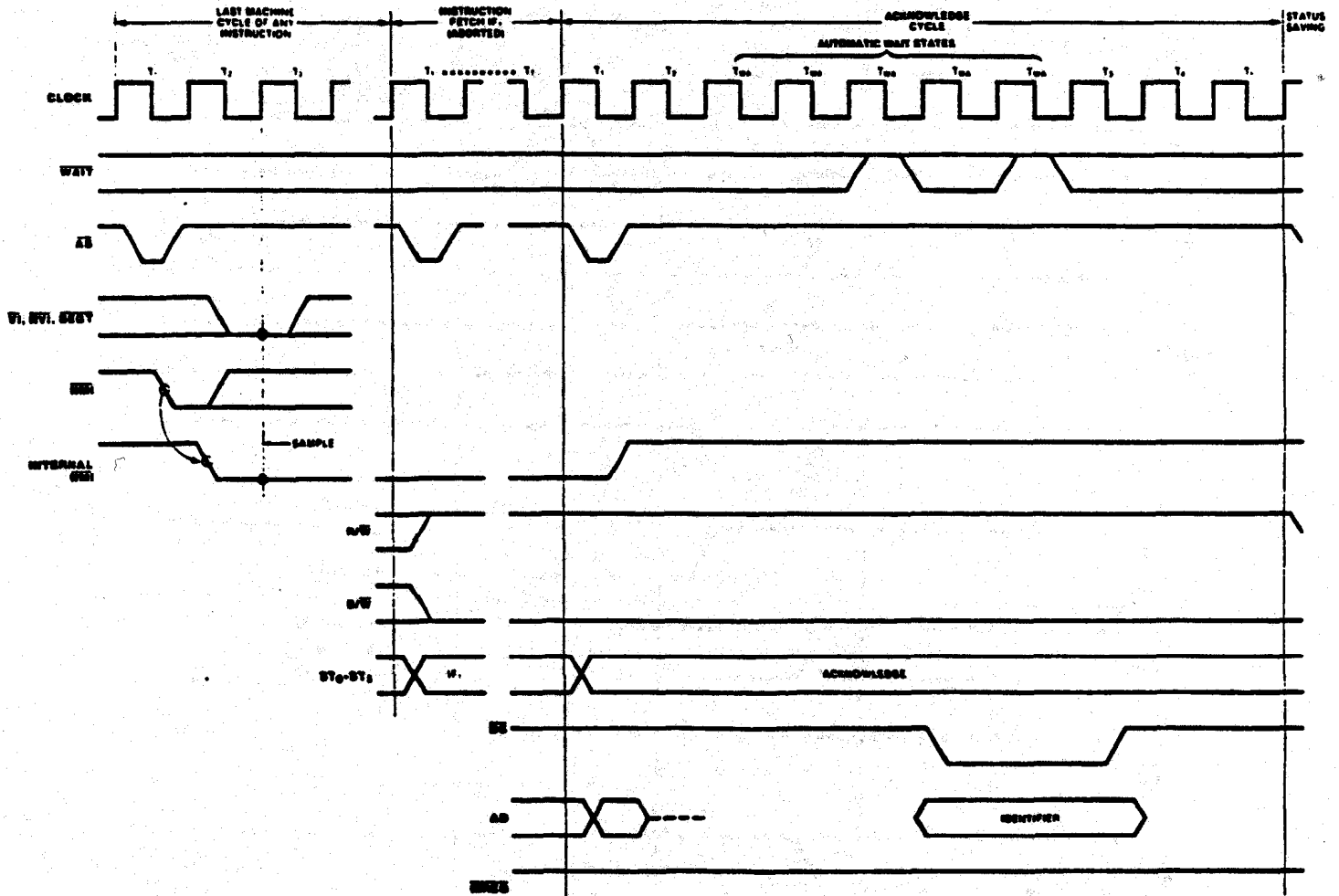

Interrupt and Segment Trap  
Request/Acknowledge Timing

TIMING DIAGRAMS (Continued)

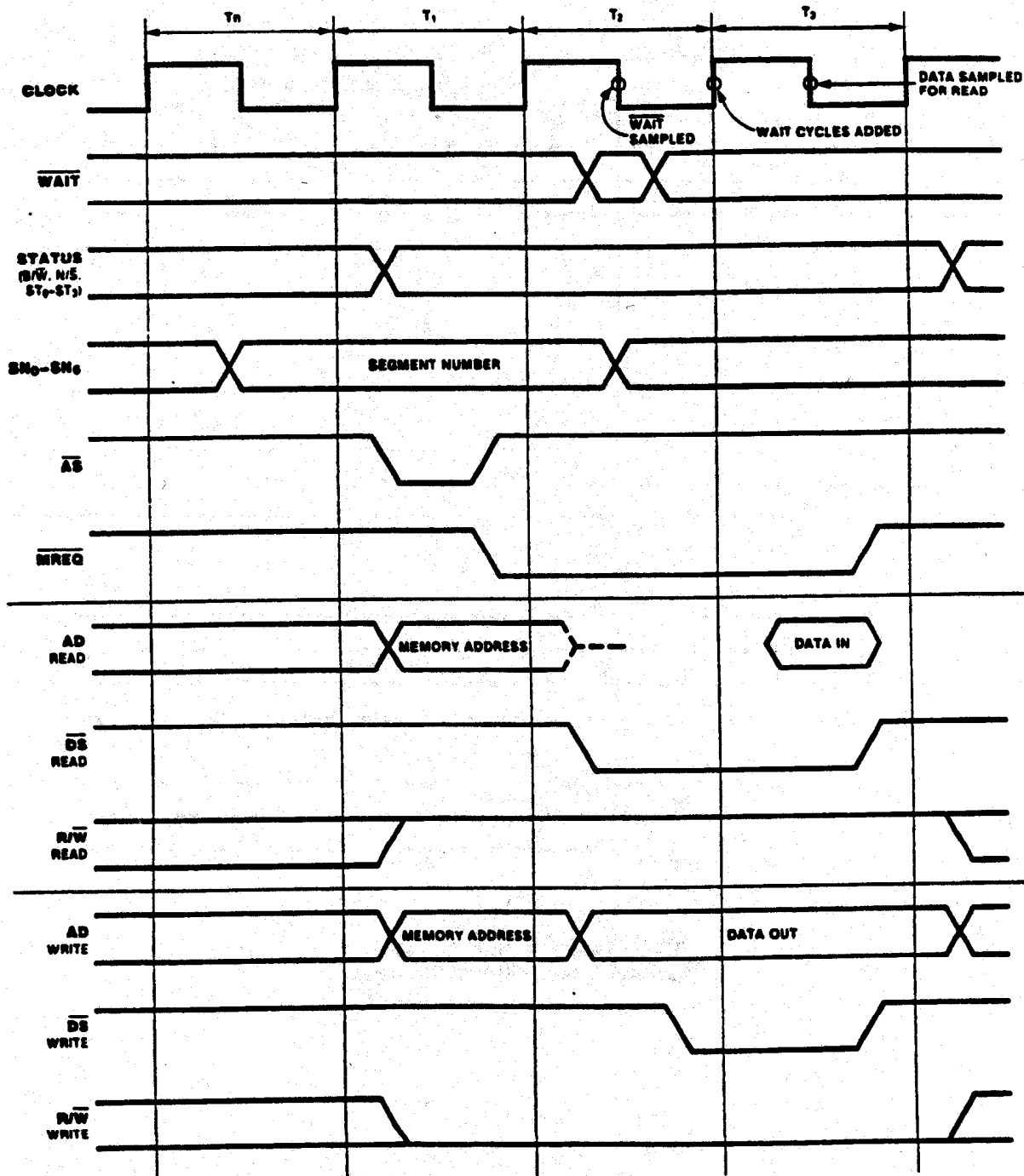

Memory Read and Write Timing

TIMING DIAGRAMS (Continued)

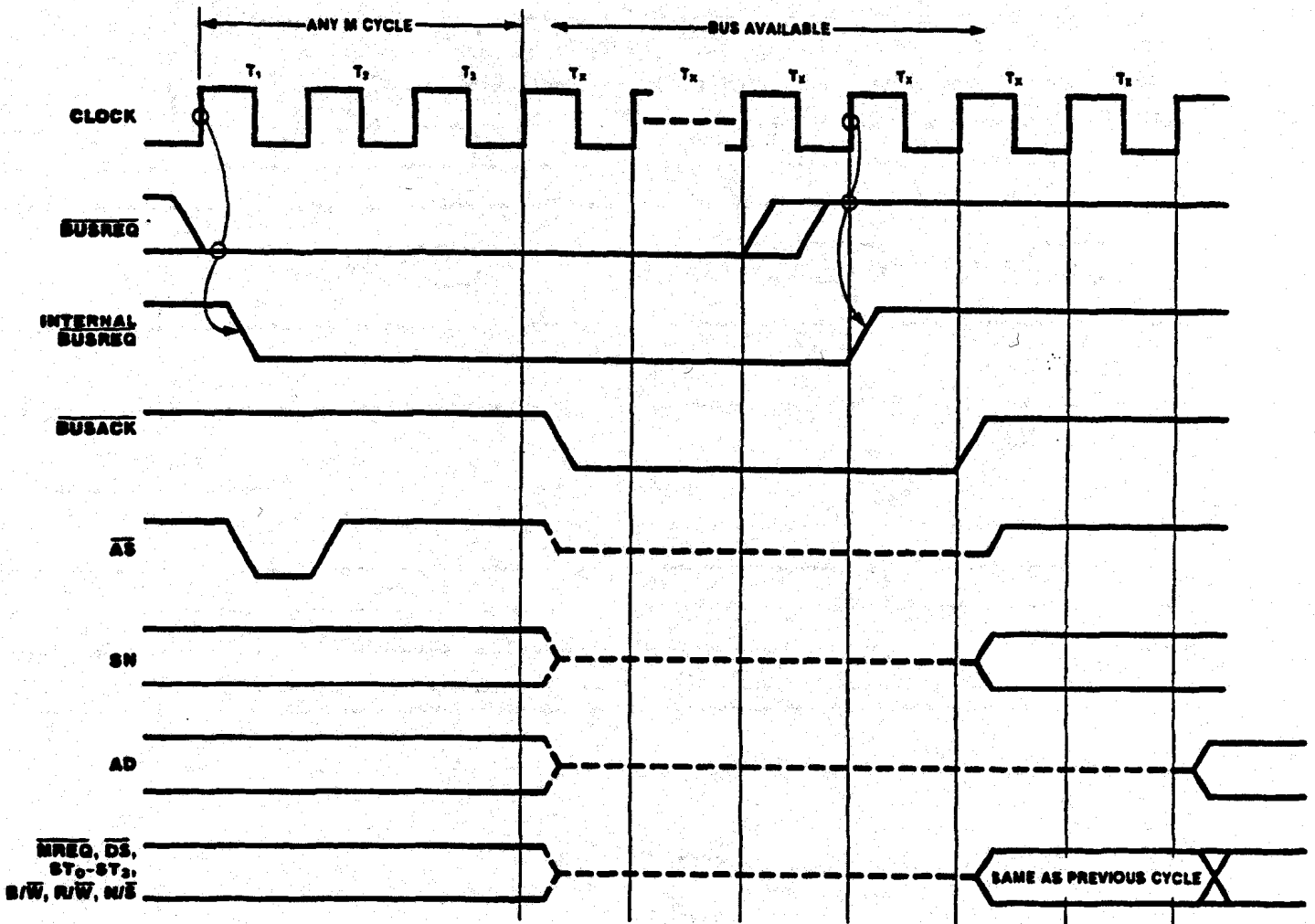

Bus Request/Acknowledge Timing

TIMING DIAGRAMS (Continued)

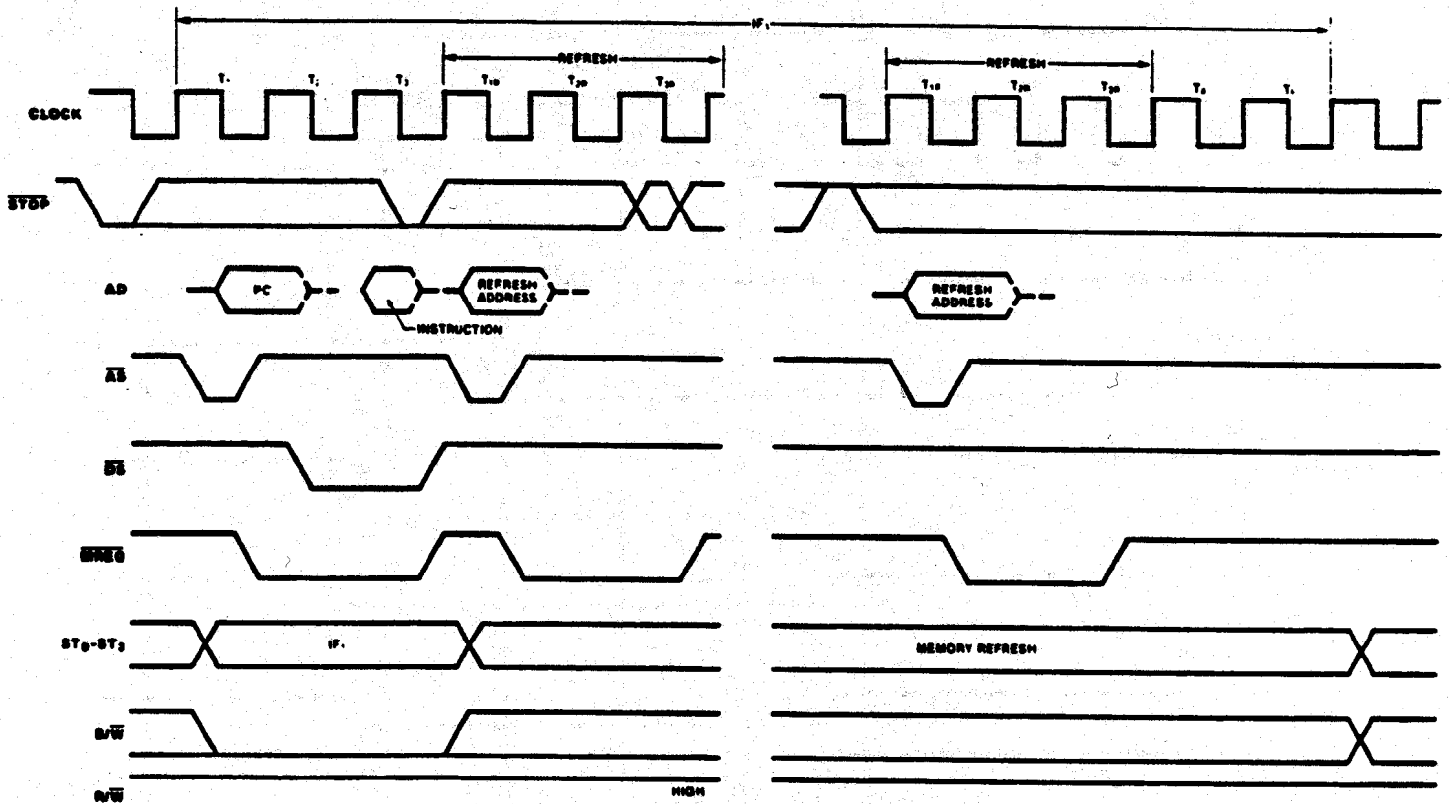

Stop Timing

© 1995 by Zilog, Inc. All rights reserved. No part of this document may be copied or reproduced in any form or by any means without the prior written consent of Zilog, Inc. The information in this document is subject to change without notice. Devices sold by Zilog, Inc. are covered by warranty and patent indemnification provisions appearing in Zilog, Inc. Terms and Conditions of Sale only. Zilog, Inc. makes no warranty, express, statutory, implied or by description, regarding the information set forth herein or regarding the freedom of the described devices from intellectual property infringement. Zilog, Inc. makes no warranty of merchantability or fitness for any purpose. Zilog, Inc. shall not be responsible for any errors that may appear in this document. Zilog, Inc. makes no commitment to update or keep current the information contained in this document.

Zilog's products are not authorized for use as critical components in life support devices or systems unless a specific written agreement pertaining to such intended use is executed between the customer and Zilog prior to use. Life support devices or systems are those which are intended for surgical implantation into the body, or which sustains life whose failure to perform, when properly used in accordance with instructions for use provided in the labeling, can be reasonably expected to result in significant injury to the user.

Zilog, Inc. 210 East Hacienda Ave.  
Campbell, CA 95008-6600  
Telephone (408) 370-8000  
Telex 910-338-7621  
FAX 408 370-8056  
Internet: <http://www.zilog.com/zilog>  
General Questions: [info@zilog.com](mailto:info@zilog.com)