

MMA504 DC to 4.0 GHz Amplifier

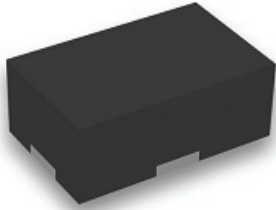

2012 OUTLINE

Description:

MMA504 is a fully matched amplifier fabricated in Aeroflex / Metelics' highly reliable InGaP HBT technology and housed in a low cost 1.9 X 1.1 plastic DFN package. It is designed for wireless infrastructure, test instruments and other applications from 100 MHz up to 4 GHz.

Features:

- DC - 4.0 GHz Broadband Gain Block
- ± 0.5 dB Gain Flatness DC to 2 GHz
- Better than 15 dB Return Loss

ELECTRICAL CHARACTERISTICS, $T_c = +25$ °C, $V_s = 5V$, $R_{bias} = 22$ Ohms

Parameter	Term	Minimum	Typical	Maximum	Units
3dB Bandwidth	BW	DC	---	4.0	GHz
Frequency Range	f_o	DC	---	2.0	GHz
Gain	G_p	18	19.5	---	dB
Output Power	P_{1dB}	14.5	15.5	---	dBm
Standing Wave Ratio	VSWR	---	1.25:1	2.0:1	---
3 rd Order Intercept Point	IP3	+26	+27.8	---	dBm
Noise Figure	NF	---	4.4	5.0	dB
Device Current	I_c	42	48	55	mA
Device Voltage	V_{CC}	3.8	4	4.2	V

Maximum Ratings:

Rating	Limits	Units
I_c	60	mA
Pin CW	+10	dBm
θ_{JC}	125	
T_{OP}	-40 to +85	°C
T_J	+150	°C
T_{STG}	-65 to +125	°C
T_{SOLDER}	+260 °C per JEDEC STD-J-20C	



Revision Date: 10/22/2010

Typical RF Performance at $T_A = 25^\circ\text{C}$, $Z_o = 50 \Omega$, Small Signal, $V_s = 5\text{V}$, $R_{\text{bias}} = 22 \Omega$:

Figure 1.

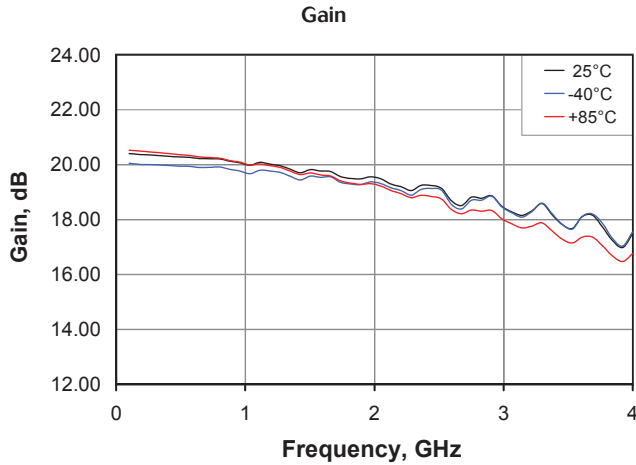

Figure 2.

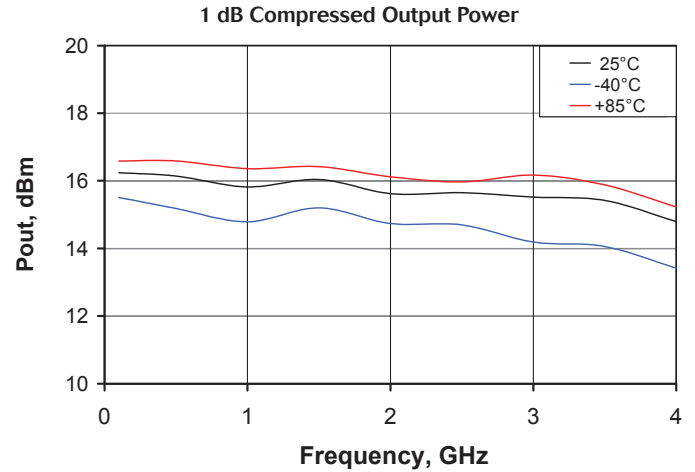

Figure 3.

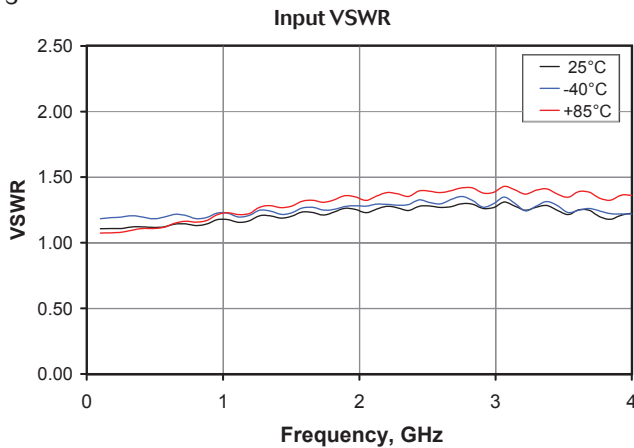

Figure 4.

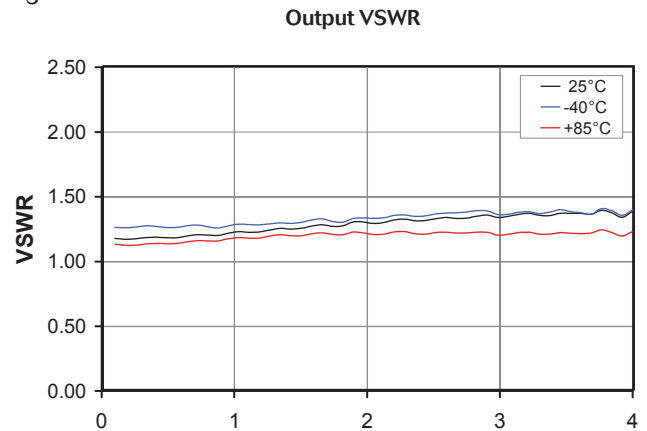

Figure 5.

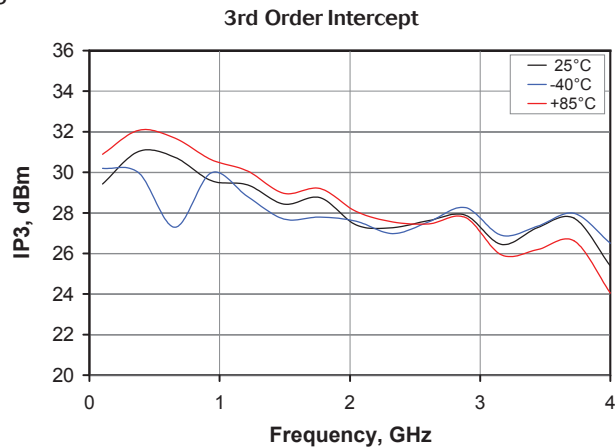
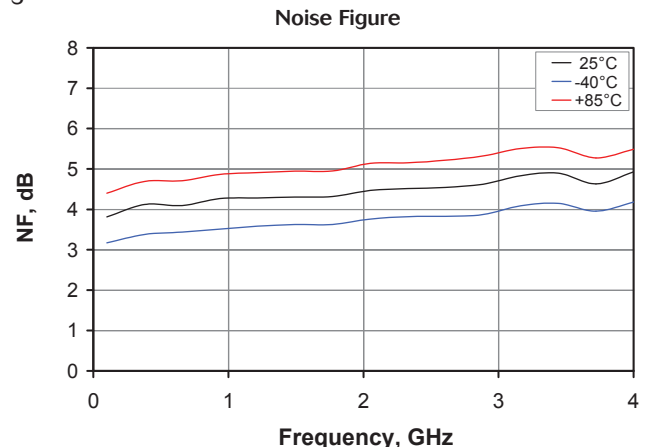

Figure 6.



MMA504 DC to 4.0 GHz Amplifier



Package Outline:

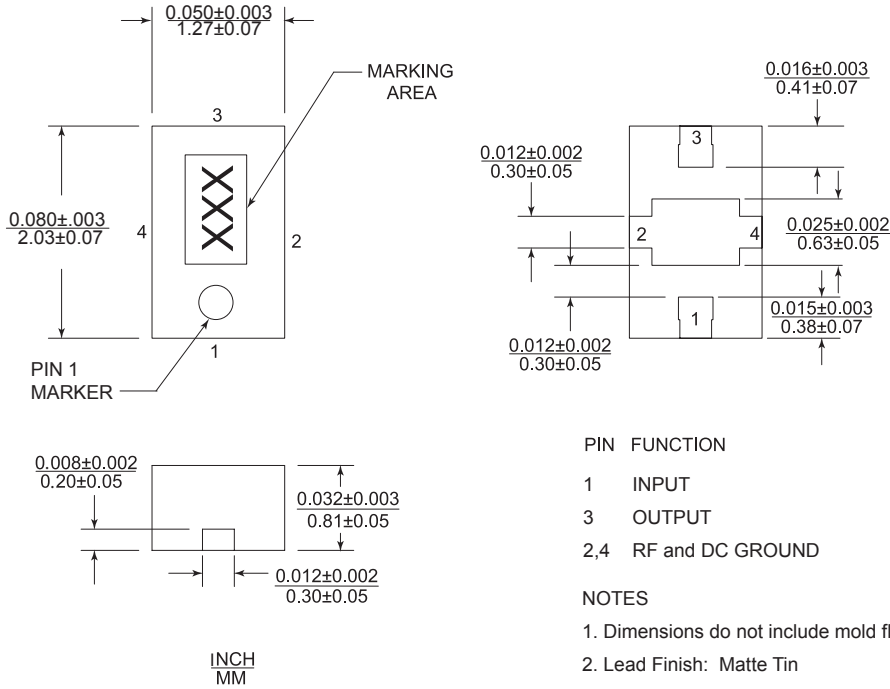

Recommended PCB Layout:

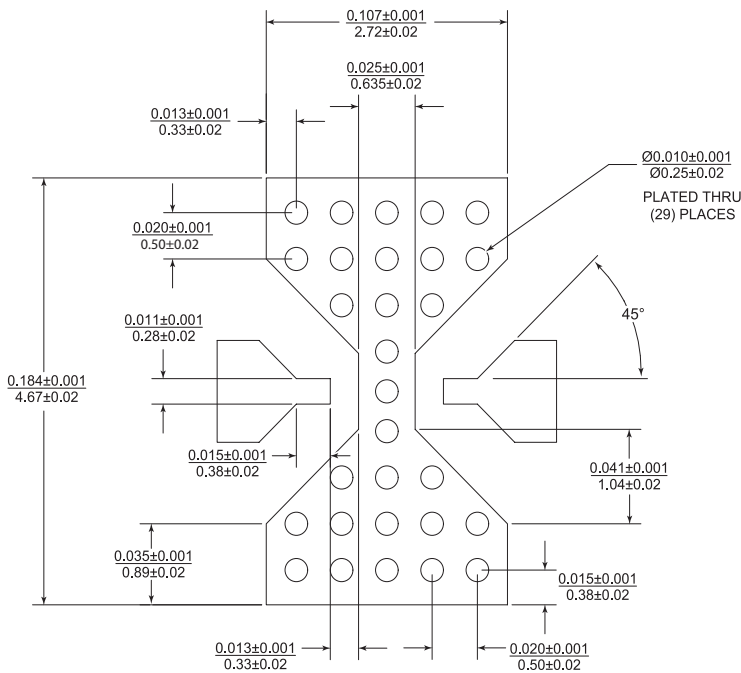

Application Circuit:

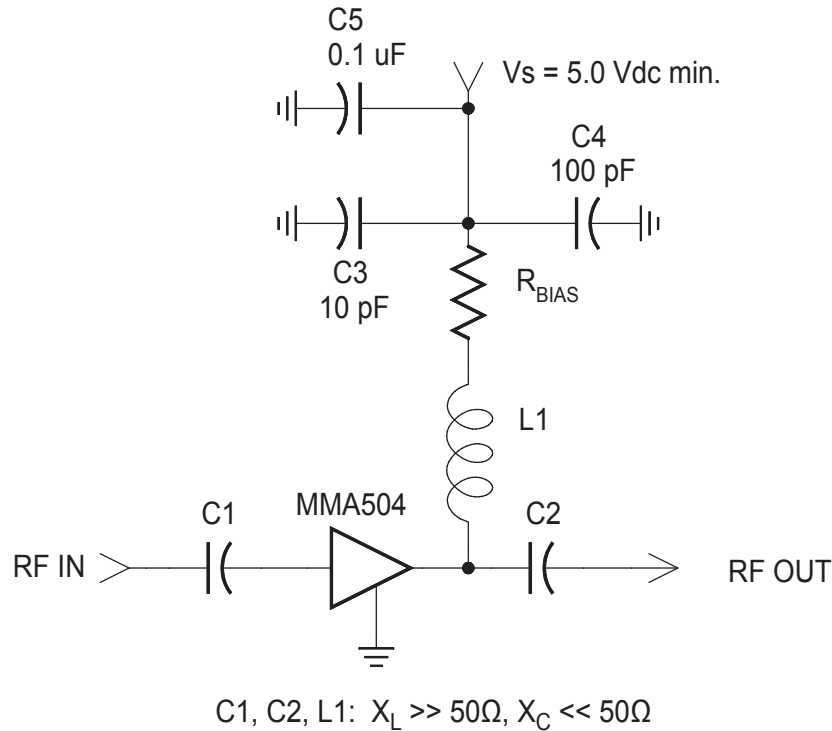

R_{BIAS} vs. V_S

V_S (V)	5.0	6.0	10.0	10.0	15.0
R_{BIAS} (Ω)	22	43	100	130	180
Power Dissipation (W)	0.05	0.1	0.2	0.3	0.4

Aeroflex / Metelics Inc.

Aeroflex Microelectronic Solutions
975 Stewart Drive
Sunnyvale, CA 94085
TEL: 408-737-8181

54 Grenier Field Road
Londonderry, NH 03053
TEL: 603-641-3800

ISO 9001:2008 certified companies

Sales

888-641-SEMI (7364)
metelics-sales@aeroflex.com

www.aeroflex.com/Microwave www.aeroflex.com/Metelics

Aeroflex / Metelics, Inc. reserves the right to make changes to any products and services herein at any time without notice. Consult Aeroflex or an authorized sales representative to verify that the information in this data sheet is current before using this product. Aeroflex does not assume any responsibility or liability arising out of the application or use of any product or service described herein, except as expressly agreed to in writing by Aeroflex; nor does the purchase, lease, or use of a product or service from Aeroflex convey a license under any patent rights, copyrights, trademark rights, or any other of the intellectual rights of Aeroflex or of third parties.

Copyright 2010 Aeroflex / Metelics. All rights reserved.



Our passion for performance is defined by three attributes represented by these three icons: solution-minded, performance-driven and customer-focused.