

Data Sheet



SCA2100-D01 2-AXIS ACCELEROMETER WITH DIGITAL SPI INTERFACE

Features

- 3.3V supply voltage
- $\pm 2g$ measurement range
- 2-axis measurement XY directions
- $\pm 70mg$ offset accuracy over temp range
- SPI digital interface
- Enhanced self diagnostics features
- Size 7.0 x 3.3 x 8.6 mm (w x h x l)
- Qualified according to the AEC-Q100 standard
- Package, pin-out and SPI protocol compatible with VTI digital accelerometer product family
- RoHS compliant Dual Flat Lead (DFL) plastic package suitable for lead-free soldering processes and SMD mounting
- Proven capacitive 3D-MEMS technology

Applications

The SCA2100-D01 is targeted at automotive applications. Typical applications include

- Electronic Stability Control (ESC)
- Hill Start Aid (HSA)
- Electronic Parking Brake (EPB)
- Roll Over
- Suspension
- Inclination
- Industrial applications

General Description

The SCA2100-D01 is a two axis accelerometer component based on VTI's capacitive 3D-MEMS technology. The component integrates high accuracy micromechanical acceleration sensing together with a flexible SPI digital interface. The component's Dual Flat Lead (DFL) housing guarantees robust operation over the product lifetime.

The SCA2100-D01 is designed, manufactured and tested for high stability, reliability and quality requirements of automotive applications. The accelerometer has an extremely stable output over wide ranges of temperature, humidity and mechanical noise. The component is qualified according to the AEC-Q100 standard and has several advanced self diagnostics features. The DFL housing is suitable for SMD mounting and the component is compatible with the RoHS and ELV directives.

The SCA2100-D01 is a part of VTI's digital accelerometer family and is compatible with its single axis accelerometers (SCA8X0 Series) and other multi axis accelerometers (SCA21X0 Series and SCA31X0 Series).

Performance Characteristics

Vdd=3.3 V and ambient temperature unless otherwise specified.

Parameter	Condition				Units
		Min	Typ	Max	
Analog and digital Vdd		3.0		3.6	V
Current consumption	Active mode		3	5	mA
	Power down mode		0.12		mA
Measurement range	Measurement axes (XY)	-2		2	g
Operating temperature		-40		125	°C
Offset total error ^{A)}	Temperature range -40 ... +125 °C	-100		100	mg
Offset temperature dependency ^{B)}	Temperature range -40 ... +125 °C	-70		70	mg
Sensitivity	12 bit output		900		Count/g
Total sensitivity error		-4		4	% FS
Linearity error	+1g ... -1g range	-20		20	mg
Cross-Axis sensitivity				±3.5	%
Zero acceleration output	2-complement		0		Counts
Amplitude response ^{C)}	-3dB frequency	30		55	Hz
Noise				5	mg RMS
Power on setup time				0.1	s
Output data rate			2000		Hz
Output load				50	pF
SPI clock rate				8	MHz
ESD protection	Human Body Model			2	kV
	Charge Device Model			1	kV
Moisture sensitivity level	IPC/JEDEC J-STD-020C, Level 3				
Mechanical shock				20 000	g

- A) Includes offset deviation from 0g value including calibration error and drift over lifetime, temperature and supply voltage.
 B) Offset drift due to temperature. Value is a relative value and has not to be centered to zero.
 C) See figure 4.

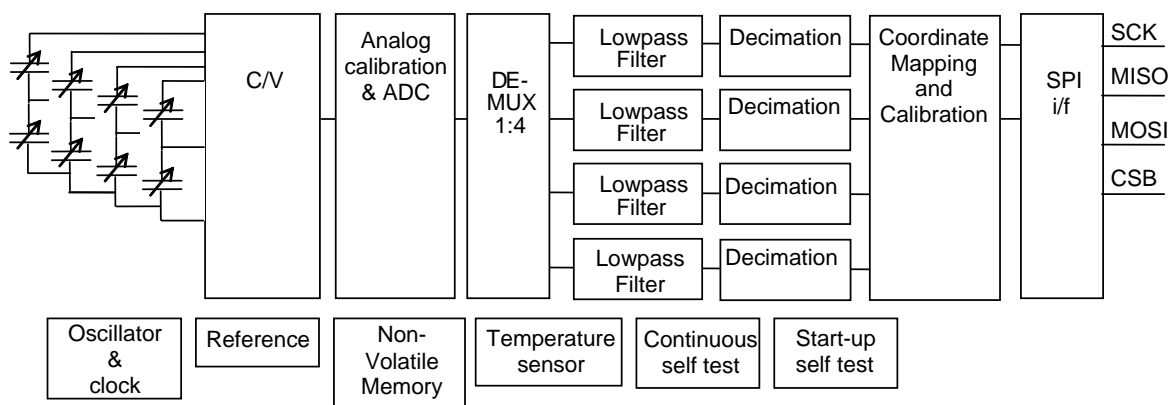

Figure 1. SCA2100-D01 Block diagram

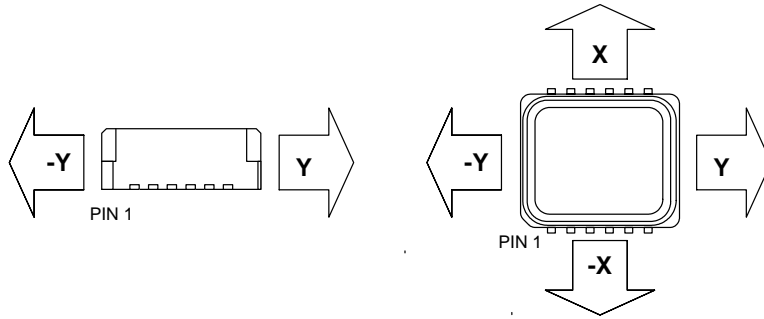

Figure 2. Accelerometer measuring directions

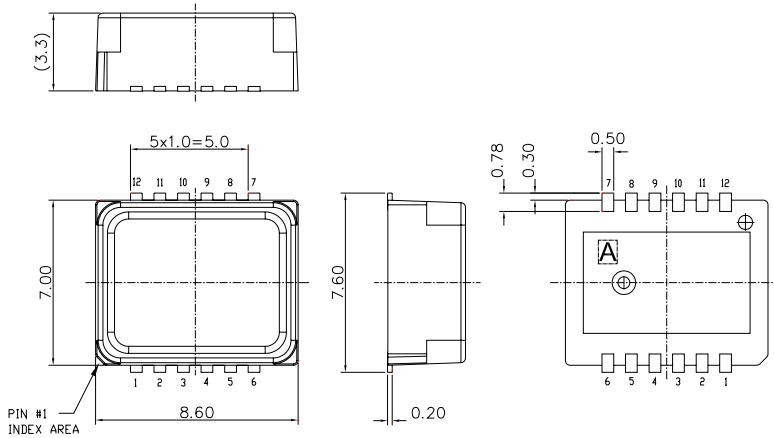

Figure 3. Housing dimensions

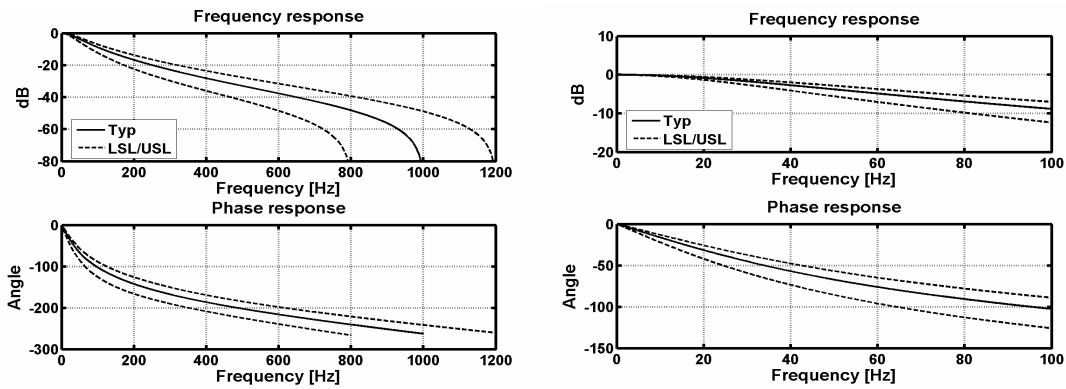

Figure 4. Frequency response curves

Document Change Control

Rev.	Date	Change Description
A	07.10.06	Preliminary version