

RJ45 Modular Jack Connectors with Pulse Transformers

TM11RD - 5TANA Series

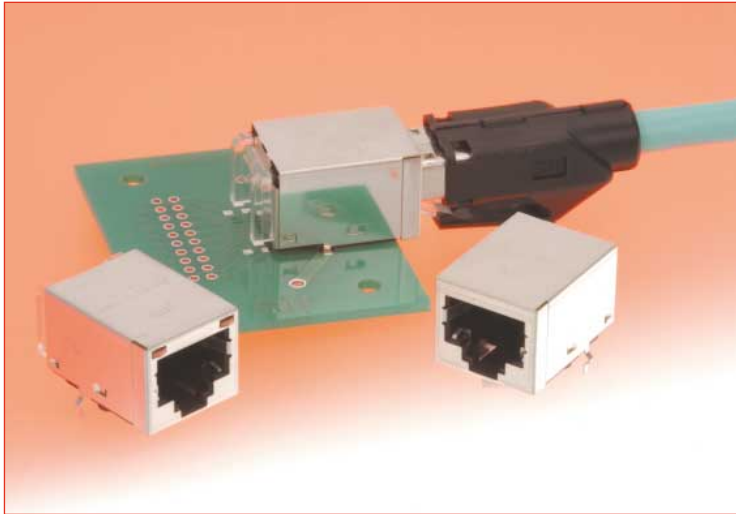

Pulse Transformer Circuit Diagram

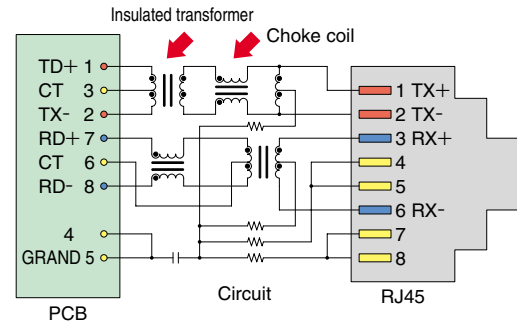

■ Features

1. Pulse Transformers Support FastEthernet

Equipped with built-in insulation transformers and common mode choke coils, withstanding voltage of 1.5 kV and supporting 100Base-Tx and 10Base-T.

2. Incorrect Plug Insertion Prevention Key

A built-in key offers protection against insertion of 6-conductor type modular plug.

3. Built-in optical indicators

Optical indicators are integral part of the connectors, saving space on the board. There is no emission of any electrical noise.

4. EMI protection

Metal shield covers the outer surfaces of the connectors assuring complete protection against electromagnetic interference.

5. FCC standards

Meets requirements of FCC Title 47, Part 68, Subpart F.

6. Environmental considerations

Plating compounds are lead-free.

■ Applications

Notebook PC's, telecommunication hubs, routers, bridges and ATM transmission equipment, Ethernet switches and networking equipment, office equipment, test and measurement equipment.

RJ11 (6 position) plug insertion prevention

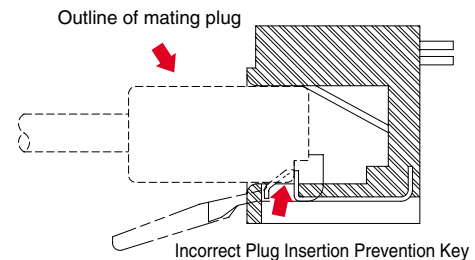

Built-in optical indicators

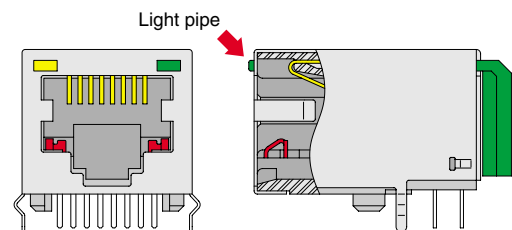

* Light colors are determined by the color of LED's used.

■Product Specifications

Ratings	Voltage rating 125V AC	Operating temperature range: -25°C to +80°C (Note)
---------	------------------------	--

	Item	Specification	Conditions
Connector	1.Insertion resistance	-2dB min.	1 to 65MHz
	2.Insulation resistance	100M ohms min.	100V DC
	3.Withstanding voltage	No flashover or insulation breakdown.	Basic terminal between 123-45-768 500V AC / one minute Primary (RJ45 side) to secondary (PCB side) 1500V AC / one minute Terminal to shield 1500V AC / one minute
Pulse transformer	4.Insertion resistance	-1dB min.	1 to 65MHz
	5.Return loss	-20 dB max.	1 to 10 MHz
		-16 dB max.	10 to 30 MHz
		-12 dB max.	30 to 60 MHz
		-10 dB max.	60 to 80 MHz
	6.Inductance	350μH min.	0.1V, 100KHz, 8mADC
7.Cross talk (Reference)	-40 dB max.	1 to 30 MHz	
	-35 dB max.	30 to 60 MHz	
	-30 dB max.	60 to 100 MHz	
8.Common mode rejection ratio (Reference)	-30 dB max.	1 to 50 MHz	
	-20 dB max.	50 to 150 MHz	

Note: Includes temperature rise caused by current flow.

■Materials

Component	Material	Finish/Color	Remarks
Insulator	PBT	Black	UL94V-0
Contacts	Copper alloy	Contact area : Gold plated Termination area: Tin plated	
Shield	Copper alloy	Tin plated	
Incorrect insertion prevention key	Stainless		
Pulse transformer	—	—	
Optical pipe	Polycarbonate	Clear	UL94V-0

■Ordering information

TM11 R D - 5 T A NA - A - 8 8 - LP

① ② ③ ④ ⑤ ⑥ ⑦ ⑧ ⑨ ⑩

① Series name	: TM11
② Connector type	R: Jack
③ Direction of locking lever (mating plug)	D: Down
④ Jack suffix number	: 5
⑤ Transformer	T: With transformer
⑥ Transformer type	A: Transformer circuit type
⑦ Incorrect insertion prevention key	NA-A: With built-in key
⑧ Jack opening code	8: 8 contacts
⑨ Number of inserted contacts	8: 8 contacts
⑩ Optical pipe	LP: With optical pipe inserted Blank: Without optical pipe

■ Modular Jack Connectors (With built-in optical pipe)



Part Number	CL No.	RoHS
TM11RD-5TANA-A-88-LP	CL222-2936-3	YES

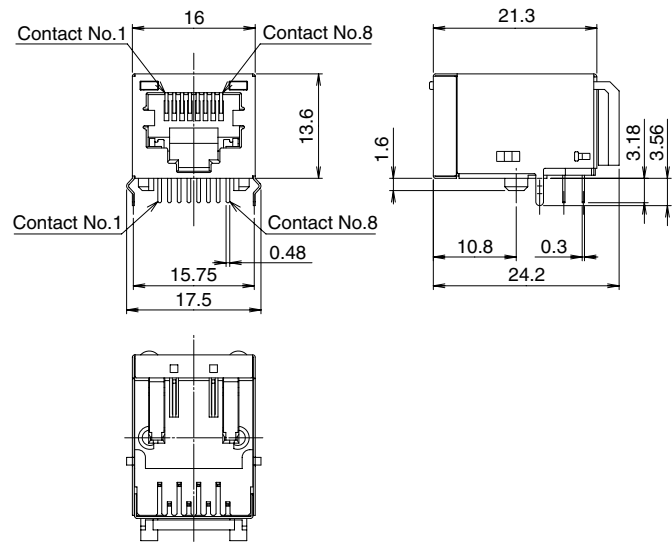

◆ Recommended PCB mounting pattern

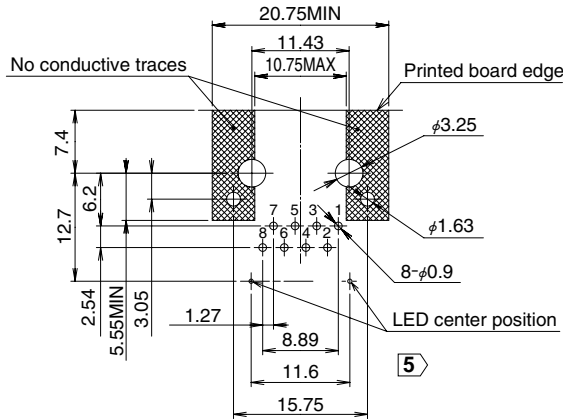

4 Suggested dimensions of LEDs

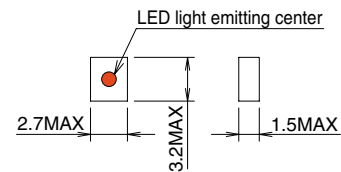

◆ Pulse Transformer Circuit Diagram

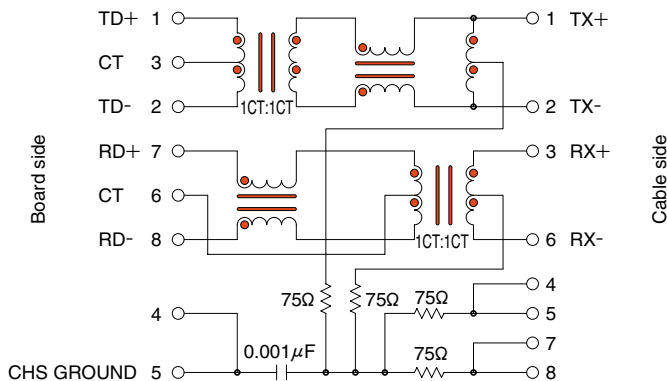

● Precautions

- Hirose Electric did not check the compatibility with the PHY chip. When replacing other manufacturers jack it is recommended to verify the compatibility with the actual equipment.
- This connector is mounted on the board using wave or manual soldering. Do not use reflow soldering.
- Recommended board thickness: 1.6mm
- To assure correct operation of the indicator light pipes LED's must be installed directly on the PCB, within recommended dimensions and with light emitting center in upward direction.
- Mount the LED so that the center of the light emitting center aligns with the center point as dimensioned on the Recommended PCB mounting pattern above.
- Verify the actual LED's mounting pattern with it's manufacturer, then add it to the PCB mounting pattern, assuring the correct placement of the center point.
- IPA cleaning at room temperature is recommended for the cleaning of this product.
 When an aqueous cleaning agent is to be used, there is a concern that the light pipe (made of polycarbonate resin) may change color; therefore, please make a selection based on a table showing the effects on the resin. These tables are issued by the various manufacturers of cleaning agents.

■Modular Jack Connectors (Without built-in optical pipe)

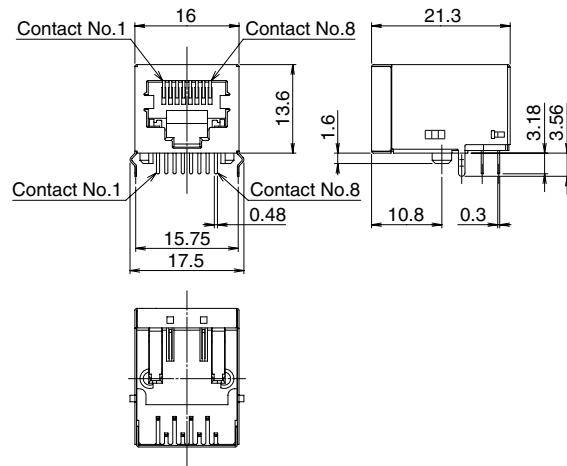
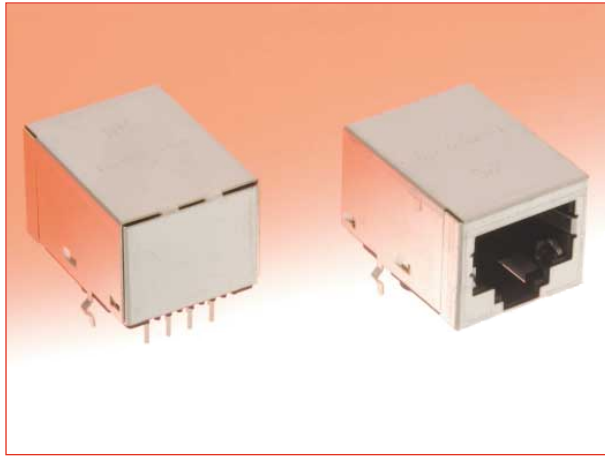

Part Number	CL No.	RoHS
TM111RD-5TANA-A-88	CL222-2932-2	YES

◆Recommended PCB mounting pattern

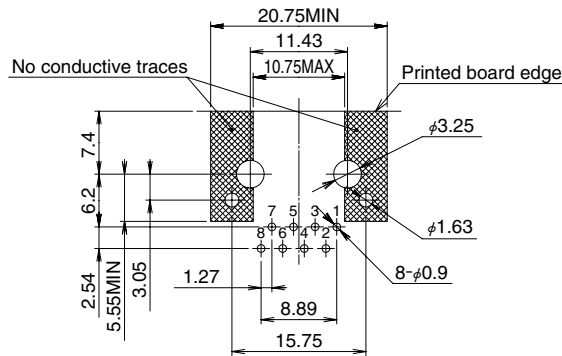

◆Pulse Transformer Circuit Diagram

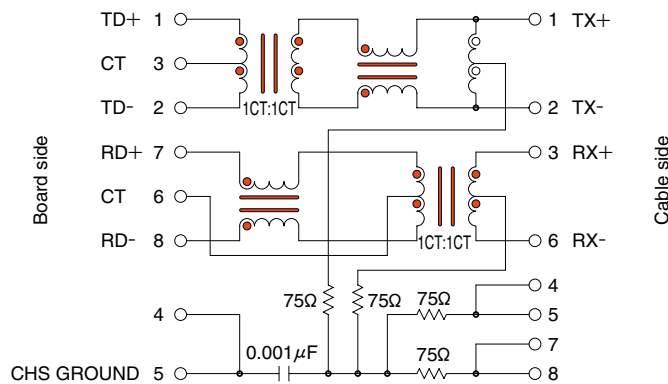

●Precautions

- Hirose Electric did not check the compatibility with the PHY chip. When replacing other manufacturers jacks it is recommended to verify the compatibility with the actual equipment.
- This connector is mounted on the board using wave or manual soldering. Do not use reflow soldering.
- Recommended board thickness: 1.6mm
- IPA cleaning at room temperature is recommended for the cleaning of this product.
 When an aqueous cleaning agent is to be used, there is a concern that the light pipe (made of polycarbonate resin) may change color; therefore, please make a selection based on a table showing the effects on the resin. These tables are issued by the various manufacturers of cleaning agents.

■ Technical Data

Measurement results of electrical characteristics

● Insertion Loss

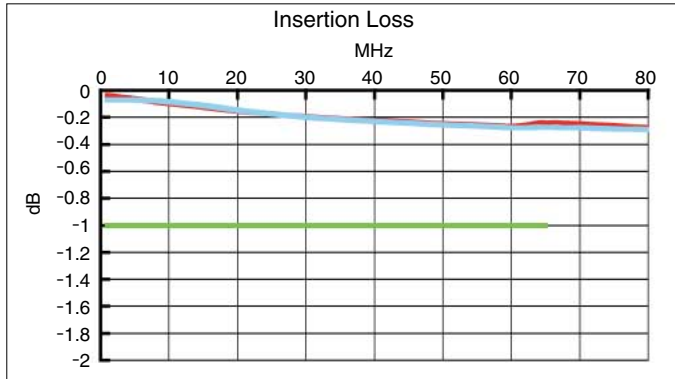
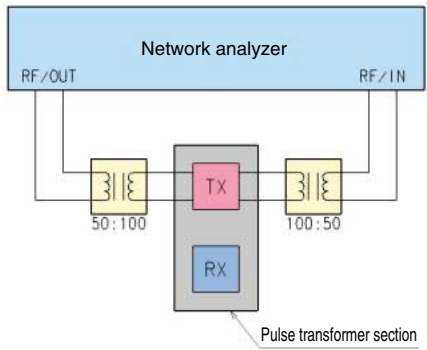

● Reflection Loss

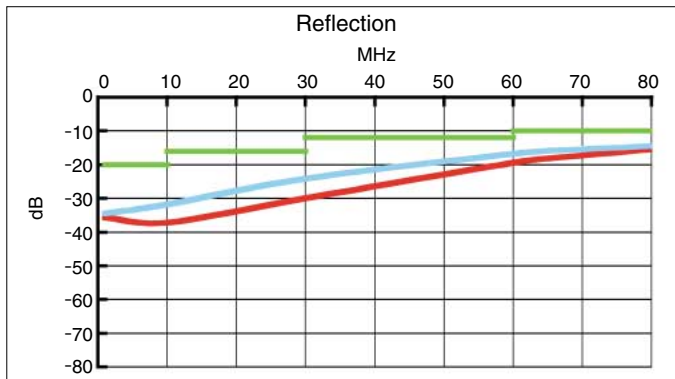
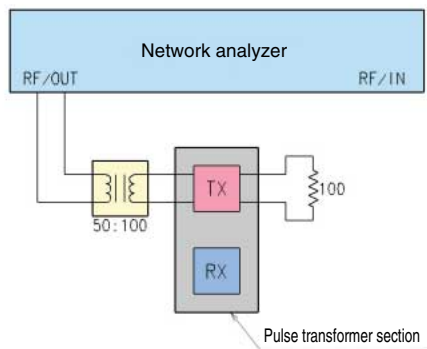

● Crosstalk (Reference)

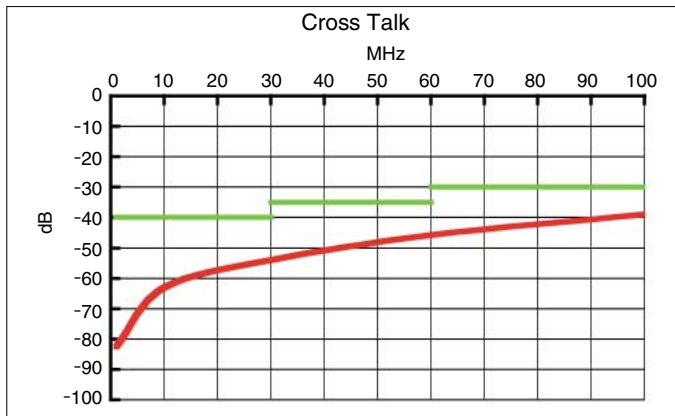
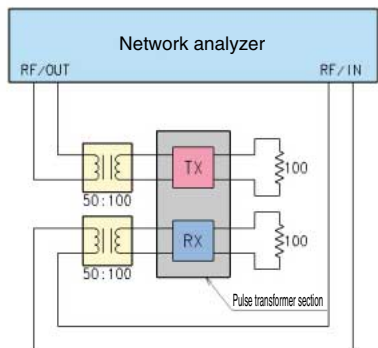

● Common Mode Rejection Ratio (Reference Value)

