

Preliminary Data Sheet

OM6423SP6
OM6424SP6

OM6425SP6
OM6426SP6

POWER MOSFETS IN 11-PIN INDUSTRIAL SIP PACKAGE

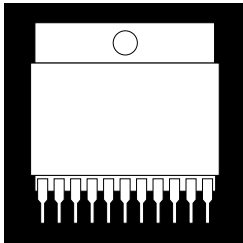

Industrial 11-Pin, 150 to 500 V, N-Channel Power MOSFET, Full "H" Bridge

FEATURES

- Low $R_{DS(on)}$
- Fast Switching
- Single SIP Package
- 3 Voltage, Current Ratings

DESCRIPTION

This series of "H" Bridge configured circuits provides the user with a low cost solution to power control. Ideally suited for stepper motors, limited span designs, lighting systems, and D.C. motor applications.

2.1

SCHEMATIC

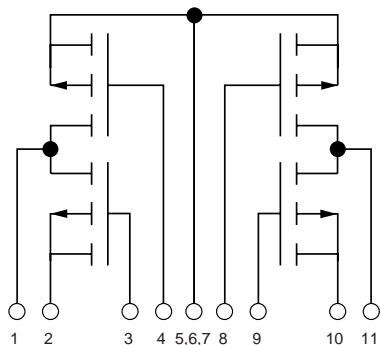

MECHANICAL OUTLINE

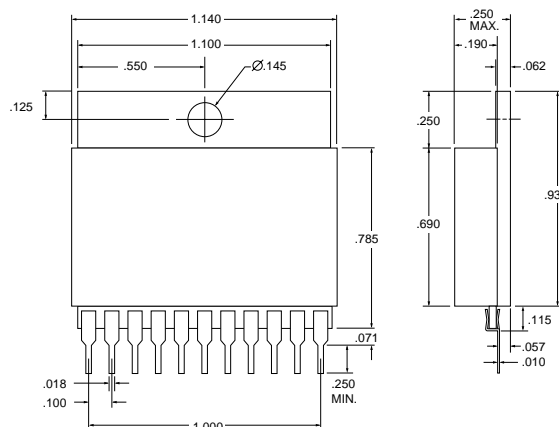

FOR FURTHER INFORMATION, CONTACT FACTORY DIRECT OR YOUR LOCAL SALES REPRESENTATIVE.
This document contains information on a new product. Specifications and information herein are subject to change without notice.

OM6423SP6 - OM6426SP6

ELECTRICAL CHARACTERISTICS: T = 25° unless otherwise noted.

Characteristic	Symbol	6423SP6		6424SP6		Units
		Min.	Max.	Min.	Max.	
Drain-Source Breakdown Voltage ($V_{GS} = 0, I_D = 0.25mA$)	$V_{(BR)DSS}$	50	150	100	-	V _{dc}
Zero Gate Voltage Drain Current ($V_{DS} = \text{Rated } V_{DSS}, V_{GS} = 0$) ($V_{DS} = \text{Rated } V_{DSS}, V_{GS} = 0, T_J = 85^\circ C$)	I_{DSS}	-	250 1000	-	250 1000	μA
Gate-Body Leakage Current, Forward ($V_{GSF} = \pm 20 \text{ Vdc}, V_{DS} = 0$)	I_{GSSF}	500	500	500	500	nA
Gate Threshold Voltage ($V_{DS} = V_{GS}, I_D = 250\mu A$)	$V_{GS(th)}$	2.0	4.0	2.0	4.0	V
Static Drain-Source-On-Resistance ($V_{GS} = 10V_{dc}$)	$r_{DS(on)}$.02	.08	-	.16	
Drain-Source-On-Voltage ($V_{GS} = 10V, T_J = 85^\circ C$)	@ $I_D =$ $V_{DS(on)}$	-	5.0 .4	-	4.0 .64	A V
Forward Transconductance ($V_{DS} = 10V, I_D = 12A$)	g_{FS}	-	8.0	-	5.0	mhos
Input Capacitance	($V_{DS} = 25V,$ $V_{GS} = 0,$ $f = 1MHz$) C_{iss}	-	700	-	850	pF
Output Capacitance	C_{oss}	-	450	-	260	pF
Reverse Transfer Capacitance	C_{rss}	-	180	-	50	pF
Turn-On Delay Time ($V_{DD} = 25V, I_D = 2A$)	$t_{d(on)}$	-	20	-	30	ns
Turn-Off Delay Time ($V_{DD} = 25V, I_D = 2A$)	$t_{d(off)}$	-	110	-	40	ns
Source Drain Diode Forward On Voltage $I_1 = 10$	V_{SD}	-	1.6	-	1.6	V

ELECTRICAL CHARACTERISTICS: T = 25° unless otherwise noted.

Characteristic	Symbol	6425SP6		6426SP6		Units
		Min.	Max.	Min.	Max.	
Drain-Source Breakdown Voltage ($V_{GS} = 0, I_D = 0.25mA$)	$V_{(BR)DSS}$	200	-	500	-	V _{dc}
Zero Gate Voltage Drain Current ($V_{DS} = \text{Rated } V_{DSS}, V_{GS} = 0$) ($V_{DS} = \text{Rated } V_{DSS}, V_{GS} = 0, T_J = 85^\circ C$)	I_{DSS}	-	250 1000	-	250 1000	μA
Gate-Body Leakage Current, Forward ($V_{GSF} = \pm 20 \text{ Vdc}, V_{DS} = 0$)	I_{GSSF}	500	500	500	500	nA
Gate Threshold Voltage ($V_{DS} = V_{GS}, I_D = 250\mu A$)	$V_{GS(th)}$	2.0	4.0	2.0	4.0	V
Static Drain-Source-On-Resistance ($V_{GS} = 10V_{dc}$)	$r_{DS(on)}$	-	.8	-	3.0	
Drain-Source-On-Voltage ($V_{GS} = 10V, T_J = 85^\circ C$)	@ $I_D =$ $V_{DS(on)}$	-	2.0 1.6	-	1.0 3.0	A V
Forward Transconductance ($V_{DS} = 10V, I_D = 12A$)	g_{FS}	-	1.3	-	1.0	mhos
Input Capacitance	($V_{DS} = 25V,$ $V_{GS} = 0,$ $f = 1MHz$) C_{iss}	-	600	-	400	pF
Output Capacitance	C_{oss}	-	300	-	150	pF
Reverse Transfer Capacitance	C_{rss}	-	80	-	40	pF
Turn-On Delay Time ($V_{DD} = 25V, I_D = 2A$)	$t_{d(on)}$	-	40	-	60	ns
Turn-Off Delay Time ($V_{DD} = 25V, I_D = 2A$)	$t_{d(off)}$	-	100	-	30	ns
Source Drain Diode Forward On Voltage $I_1 = 4$	V_{SD}	-	1.6	-	1.6	V