

FMCE-0528 EMI Input Filters

28 VOLT INPUT – 5 AMP

FEATURES

Attenuation to 60 dB at 500 kHz, typical

- Operating temperature -55° to +125°C
- Nominal 28 V input, -0.5 to 50 V operation with or without transorb
- Transient rating -0.5 to 80 V for 1 second
- Up to 5 A throughput current over the full input voltage range -0.5 to 50 V
- Compliant to
 - MIL-STD-461C CE03
 - MIL-STD-461D, E and F CE102
 - MIL-STD-461C CS01
 - MIL-STD-461D, E, and F CS101
- Compatible with MIL-STD-704 A-E 28 VDC power bus



MODEL	INPUT VOLTAGE (V)	CURRENT (A)
FMCE-0528	28	5
FMCE-0528-TR	28	5

DESCRIPTION

The FMCE-0528™ EMI filters have been specifically designed to reduce the input line reflected ripple current of Interpoint's MTR, MHF+, and MHV series of DC/DC converters. The filter can be used with combinations of the lower power converters; up to two MTR series converters or a single MFL series converter. These filters are intended for use in 28 volt applications which must meet MIL-STD-461C CE03 and CS01 and/or MIL-STD-461D, E and F CE102 and CS101 levels of conducted emissions.

The FMCE-0528 filters are built using thick-film hybrid technology and are hermetically sealed in metal packages for military, aerospace, and other high-reliability applications. Only ceramic capacitors are used in the filters to ensure reliable high temperature operation.

The filters are offered with standard screening, "ES" screening, or fully compliant to "883" MIL-PRF-38534 Class H screening. Standard microcircuit drawings (SMD) are available.

MIL-STD NOISE MANAGEMENT

When used in conjunction with Interpoint converters, the FMCE-0528 and FMCE-0528-TR filters reduce input ripple current within the frequency band of 100 kHz to 50 MHz. When used with an Interpoint converter, performance exceeds the CEO3 test of MIL-STD-461C and meets the requirements of CS01 of MIL-STD-461C. These filters also meet CE102 and CS101 of MIL-STD-461D, E and F.

TRANSIENT SUPPRESSION - FMCE-0528-TR ONLY

The FMCE-0528-TR filter also features an optional fast-reacting (1 pico second) transient suppressor (transorb) which begins clamping the input voltage at approximately 47 VDC, protecting the DC/DC converter from damage from induced line transients.

The FMCE-0528 does not have the transorb and is designed for those applications that require a wider input voltage range (0 to 50 V).

OPERATING TEMPERATURE

The filters are rated to operate, with no degradation of performance, over the temperature range of -55°C to +125°C (as measured at the baseplate). Above +125°C, current must be derated as specified on the following page.

INSERTION LOSS

Low DC resistance design results in a maximum power loss of less than 3% with typical input voltage.

FMCE-0528 EMI Input Filters

28 VOLT INPUT – 5 AMP

OPERATING CONDITIONS AND CHARACTERISTICS

Input Voltage Range, with or without transorb

- Continuous -0.5 to 50 VDC
- Transient -0.5 to 80 V for 1 second

Lead Soldering Temperature (10 sec per pin)

- 300°C

Storage Temperature Range (Case)

- -65°C to +150°C

Case Operating Temperature (T_C)

- -55°C to +125°C full power

Derating Output Power/Current

- Linearly from 100% at 125°C to 80% at 135°C case

Input to Output Capacitance ($T_C = 25^\circ\text{C}$)

- 0.048 μF max, any pin to case

Isolation ($T_C = 25^\circ\text{C}$)

- 100 megohm minimum at 500 V
- Any pin to case, except case pin

Electrostatic Discharge (ESD) Sensitivity per MIL-PRF-38534

- Classification 3B, 8000 V

MECHANICAL AND ENVIRONMENTAL

Size (maximum)

- Non-flanged
 - 2.100 x 1.115 x 0.400 inches (53.34 x 28.32 x 10.16 mm)
 - See case H1 for dimensions.
- Flanged
 - 2.910 x 1.115 x 0.400 inches (73.91 x 28.32 x 10.16 mm)
 - See case K2 for dimensions.

Weight (maximum)

- 54 grams

Screening

The FMCE-0528 EMI Input filter offers Standard, /ES or 883, Class H, QML screening. See Screening Tables 1 and 2 for more information.

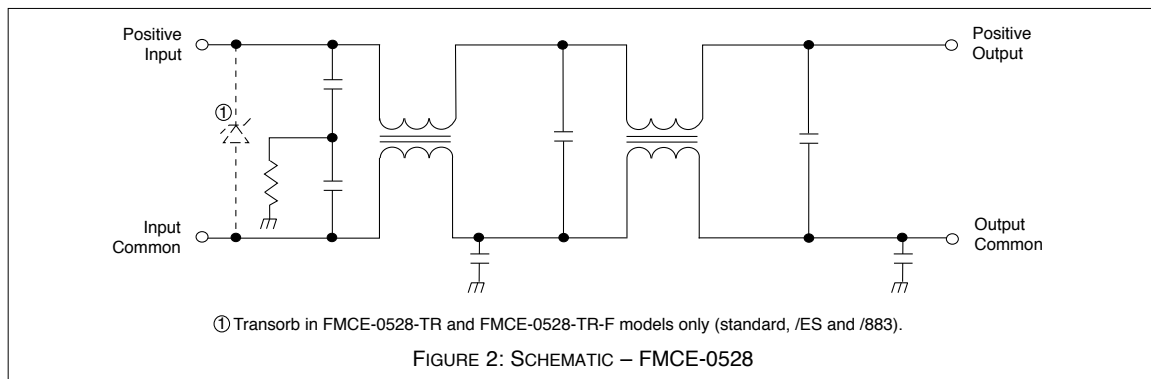
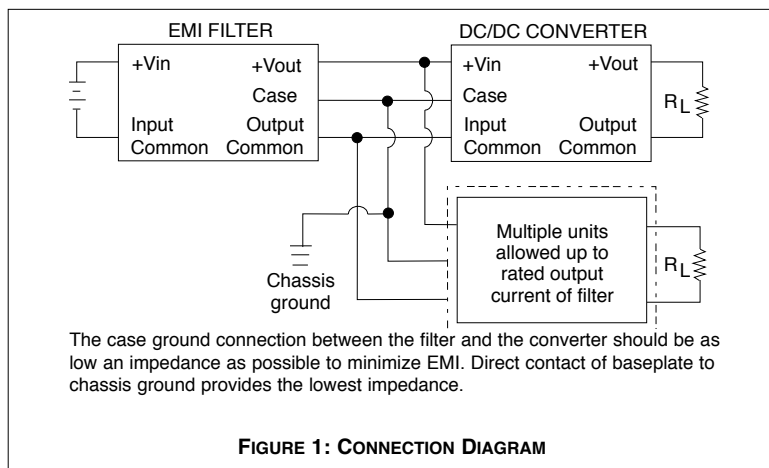

FMCE-0528 EMI Input Filters

28 VOLT INPUT – 5 AMP

PIN OUT	
Pin 1	Designation
1	Positive Input
2	Positive Output
3	Case Ground
4	Output Common
5	Input Common

Notes

1. All pins must be connected.

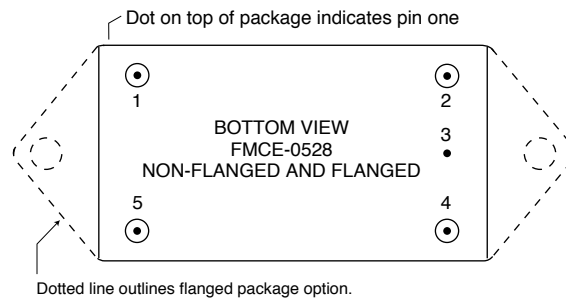

See case H1 and case K2 for dimensions.

FIGURE 3: PIN OUT

FMCE-0528 EMI Input Filters

28 VOLT INPUT – 5 AMP

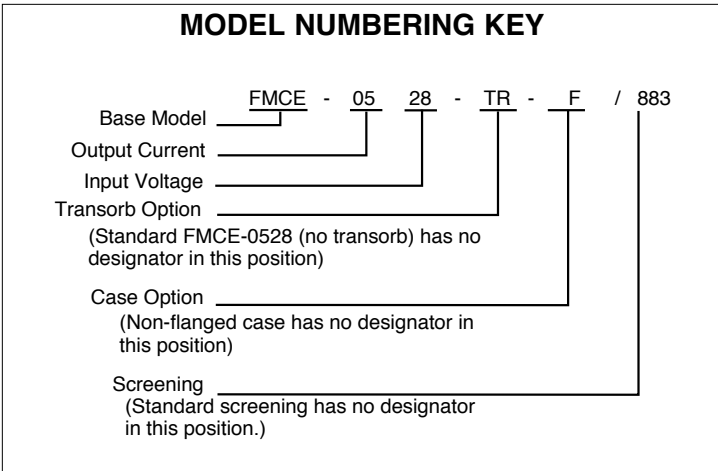

DSCC NUMBERS

DSCC DRAWING (5915)	FMCE-0528 SIMILAR PART ¹
10016-02HXC	FMCE-0528/883
10016-01HXC	FMCE-0528-TR/883
10016-02HZC	FMCE-0528-F/883
10016-01HZC	FMCE-0528-TR-F/883

1. Models with "TR" have a transorb (-01 in the DSCC numbers).

For exact specifications for a DSCC product, refer to the DSCC drawing. DSCC drawings can be downloaded from: <http://www.dscclia.mil/programs/smcr>

MODEL SELECTION

ON THE LINES BELOW, ENTER ONE SELECTION FROM UNDER EACH CATEGORY TO DETERMINE THE MODEL NUMBER.

CATEGORY	FMCE-0528 BASE MODEL AND INPUT VOLTAGE	- _____ TRANSORB OPTION ¹	- _____ CASE/LEAD OPTION ²	/	_____ SCREENING ³
SELECTION	"FMCE-0528" is the only available selection	(NO TRANSORB leave blank) TR (with transorb)	(NON-FLANGED leave blank) F (flanged)		Standard (leave blank) ES 883 (Class H, QML)

1. Transorb Option: For the standard filter (no transorb) leave the transorb option blank. For a filter with the transorb, insert the letters TR in the TR Option position.

2. Case Options: For the standard case, case H1, leave the case option blank. For the flanged case option, case K2, insert the letter F in the Case Option position.

3. Screening: For standard screening leave the screening option blank. For other screening options, insert the desired screening level. For more information see Screening Tables 1 and 2.

FMCE-0528 EMI Input Filters

28 VOLT INPUT – 5 AMP

Electrical Characteristics: -55° to +125°C T_C, nominal V_{in}, unless otherwise specified.

MODEL		FMCE-0528-TR			FMCE-0528 ²			UNITS
PARAMETER	CONDITIONS	MIN	TYP	MAX	MIN	TYP	MAX	
INPUT VOLTAGE	CONTINUOUS	-0.5	28	50	-0.5	28	50	VDC
	TRANSIENT, 1 sec ^{1,3}	-0.5	—	80	-0.5	—	80	V
INPUT CLAMPING VOLTAGE	T _C = -55°C	40.8	45.1	49.4	—	—	—	V
	T _C = 25°C	44.7	47.0	49.4	—	—	—	
	T _C = +125°C	44.7	49.5	54.2	—	—	—	
NOISE REJECTION	500 kHz	55	60	—	55	60	—	dB
	1 MHz	60	—	—	60	—	—	
DC RESISTANCE (R _{DC})	T _C = 25°C	—	0.110	0.125	—	0.110	0.125	Ω
AT MAXIMUM CURRENT	T _C = -55 AND +125°C ¹	—	—	0.150	—	—	0.150	
CAPACITANCE	ANY PIN TO CASE T _C = 25°C	—	44,000	48,000	—	44,000	48,000	pF
OUTPUT VOLTAGE ⁴	STEADY STATE	$V_{OUT} = V_{IN} - I_{IN} (R_{DC})$			$V_{OUT} = V_{IN} - I_{IN} (R_{DC})$			VDC
OUTPUT CURRENT	STEADY STATE V _{IN} = -0.5 - 50 VDC	—	—	5	—	—	5	A
POWER DISSIPATION AT MAXIMUM CURRENT ¹	T _C = 25°C	—	2.8	3.0	—	2.8	3.1	W
	T _C = 125°C	—	—	3.8	—	—	3.8	

Notes

1. **Guaranteed by design, not tested.**

2. The FMCE-0528 does not have a transorb and does not clamp the input voltage

3. 0.5 ohm source impedance

4. Typical applications result in V_{out} within 2% of V_{in}.

FMCE-0528 EMI Input Filters

28 VOLT INPUT – 5 AMP

Typical Performance Curves: 25°C T_C, nominal Vin, unless otherwise specified.

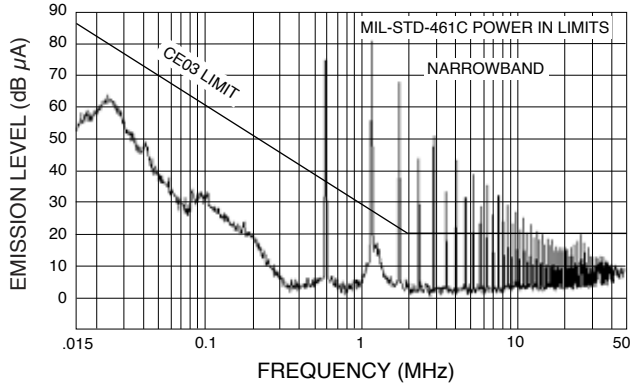

High power DC/DC converter without filtering.

FIGURE 4

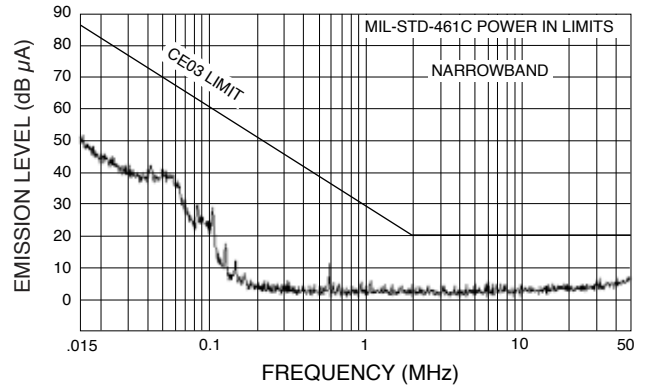

CE03: High power DC/DC converter filtered with an FMCE-0528

FIGURE 5

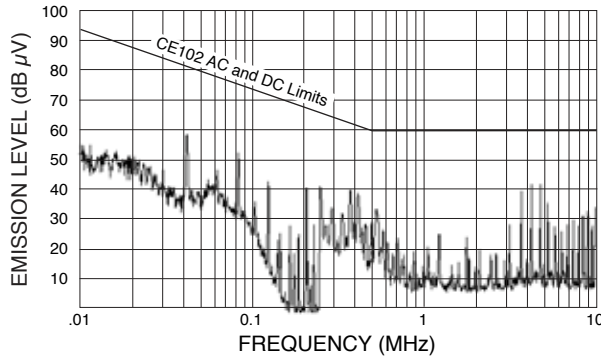

CE102: High power converter filtered with an FMCE-0528.

FIGURE 6

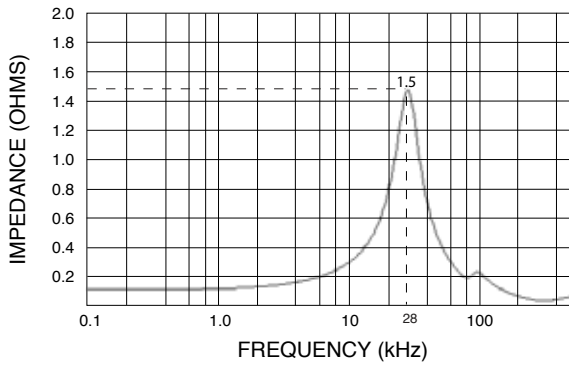

FMCE-0528 Output Impedance (measured at the output with input pins shorted)

FIGURE 7

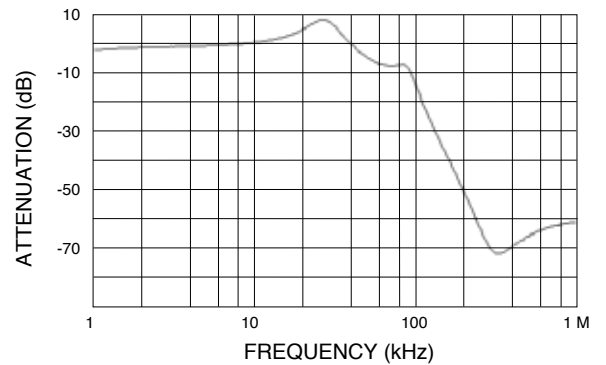

FMCE-0528 Attenuation

FIGURE 8

FMCE-0528 EMI Input Filters

28 VOLT INPUT – 5 AMP

BOTTOM VIEW CASE H1

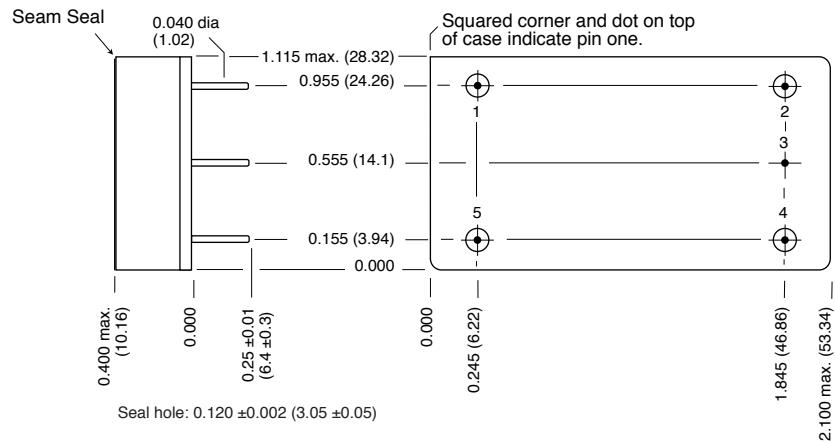

Case dimensions in inches (mm)

Tolerance ± 0.005 (0.13) for three decimal places
 ± 0.01 (0.3) for two decimal places
 unless otherwise specified

CAUTION

Heat from reflow or wave soldering may damage the device.
 Solder pins individually with heat application not exceeding 300°C for 10 seconds per pin.

Materials

Header Cold Rolled Steel/Nickel/Gold
 Cover Kovar/Nickel
 Pins #52 alloy/Gold, ceramic seal
 Seal hole 0.120 ± 0.002 (2.34 ± 0.05)

Case H1 Filters, Rev E, 20100316

Please refer to the numerical dimensions for accuracy. All information is believed to be accurate, but no responsibility is assumed for errors or omissions. Interpoint reserves the right to make changes in products or specifications without notice.
 Copyright © 1999-2009 Interpoint Corp. All rights reserved.

FIGURE 9: CASE H1

FMCE-0528 EMI Input Filters

28 VOLT INPUT – 5 AMP

BOTTOM VIEW CASE K2

Flanged cases: Designator "F" required in Case Option position of model number.

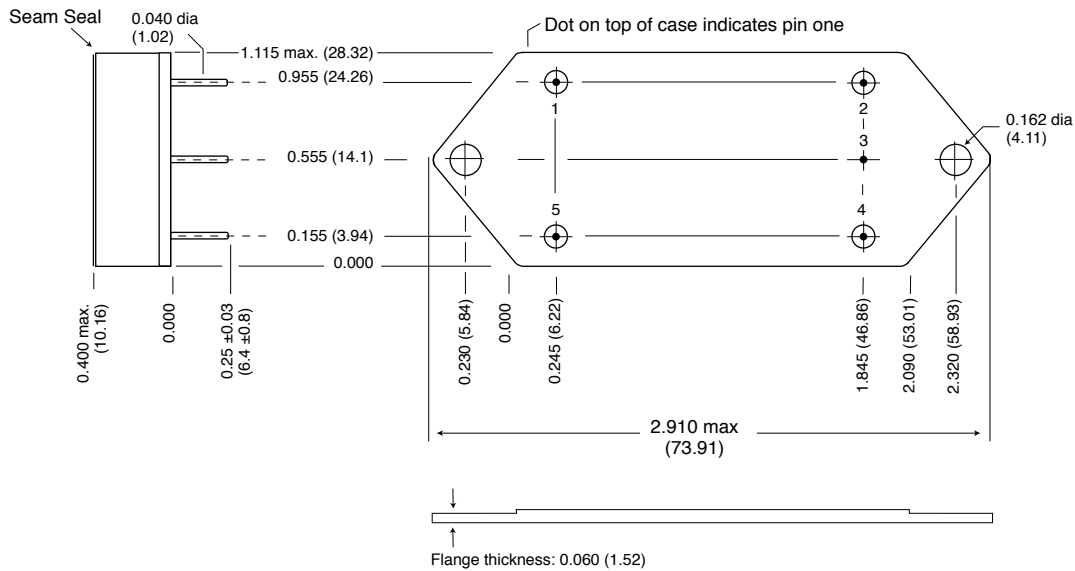

Case dimensions in inches (mm)

Tolerance ± 0.005 (0.13) for three decimal places
 ± 0.01 (0.3) for two decimal places
 unless otherwise specified

CAUTION

Heat from reflow or wave soldering may damage the device. Solder pins individually with heat application not exceeding 300°C for 10 seconds per pin.

Materials

Header Cold Rolled Steel/Nickel/Gold
 Cover Kovar/Nickel
 Pins #52 alloy/Gold, ceramic seal.
 Seal Hole: 0.120 ± 0.002 (3.04 ± 0.05)

Case K1 FMC F, Rev E, 20091111

Please refer to the numerical dimensions for accuracy. All information is believed to be accurate, but no responsibility is assumed for errors or omissions. Interpoint reserves the right to make changes in products or specifications without notice. Copyright © 1999-2009 Interpoint Corp. All rights reserved.

FIGURE 10: CASE K2

FMCE-0528 EMI Input Filters

28 VOLT INPUT – 5 AMP

STANDARD AND /ES (NON-QML) AND /883 (CLASS H, QML) PRODUCT ELEMENT EVALUATION

COMPONENT-LEVEL TEST PERFORMED	STANDARD AND /ES NON-QML ¹		/883 CLASS H QML	
	M/S ²	P ³	M/S ²	P ³
Element Electrical (probe)	yes	no	yes	yes
Element Visual	no	no	yes	yes
Internal Visual	no	N/A	yes	N/A
Final Electrical	no	no	yes	yes
Wire Bond Evaluation ⁴	no	no	yes	yes
SLAM™/C-SAM: Input capacitors only (Add'l test, not req. by H)	no	no	no	yes

Notes:

- Standard and /ES, non-QML products, do not meet all of the requirements of MIL-PRF-38534.
- M/S = Active components (Microcircuit and Semiconductor Die)
- P = Passive components
- Not applicable to EMI filters that have no wire bonds.

Definitions:

Element Evaluation: Component testing/screening per MIL-STD-883 as determined by MIL-PRF-38534
 SLAM™: Scanning Laser Acoustic Microscopy
 C-SAM: C - Mode Scanning Acoustic Microscopy

SCREENING TABLE 1: ELEMENT EVALUATION

FMCE-0528 EMI Input Filters

28 VOLT INPUT – 5 AMP

STANDARD AND /ES (NON-QML) AND /883 (CLASS H, QML) PRODUCT ENVIRONMENTAL SCREENING

TEST PERFORMED	125°C STANDARD NON-QML ¹	125°C /ES NON-QML ¹	/883 CLASS H QML
Pre-cap Inspection Method 2017, 2032	yes	yes	yes
Temperature Cycle (10 times) Method 1010, Cond. C, -65°C to 150°C, ambient Method 1010, Cond. B, -55°C to 125°C, ambient	no no	no yes	yes no
Constant Acceleration Method 2001, 3000 g Method 2001, 500 g	no no	no yes	yes no
Burn-in ² Method 1015, 125°C case, typical 96 hours 160 hours	no no	yes no	no yes
Final Electrical Test MIL-PRF-38534, Group A Subgroups 1 through 6: -55°C, +25°C, +125°C case Subgroups 1 and 4: +25°C case	no yes	no yes	yes no
Hermeticity Test Fine Leak, Method 1014, Cond. A Gross Leak, Method 1014, Cond. C Gross Leak, Dip (1 x 10 ⁻³)	no no yes	yes yes no	yes yes no
Final visual inspection Method 2009	yes	yes	yes

Test methods are referenced to MIL-STD-883 as determined by MIL-PRF-38534.

Notes:

- Standard and /ES, non-QML products, do not meet all of the requirements of MIL-PRF-38534.
- Burn-in temperature designed to bring the case temperature to +125°C

SCREENING TABLE 2: ENVIRONMENTAL SCREENING