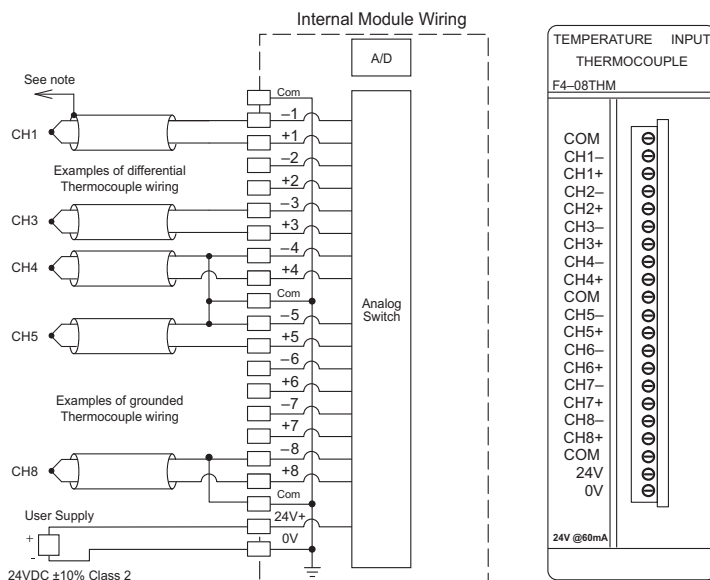
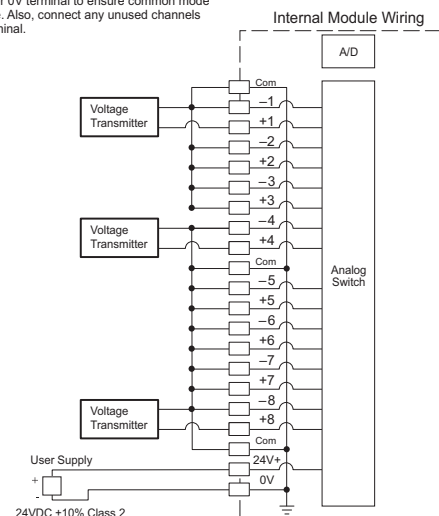

Temperature Input Modules

F4-08THM 8-Channel Thermocouple Input <--->		
General Specifications		Thermocouple Specifications
Number of Channels	8, differential	Input Ranges*
Common Mode Range	± 5VDC	
Common Mode Rejection	90dB min. @ DC, 150dB min. @ 50/60Hz.	
Input Impedance	1M Ω	
Absolute Maximum Ratings	Fault-protected inputs to ± 50VDC	
Accuracy vs. Temperature	± 5ppm/°C maximum full scale calibration (including maximum offset change)	Display Resolution
PLC Update Rate	8 channels per scan max	Cold Junction Compensation
Digital Inputs	16 binary data bits, 2 channel ID bits, 4 diagnostic bits	Conversion Time
Input Points Required	32 points (X) input module	Warm-Up Time
Terminal Type (included)	Removable (D4-16IOCON)	Linearity Error (End to End)
External Power Supply	60mA maximum, 18 to 26.4VDC	Maximum Inaccuracy
Power Budget Requirements	110mA max., 5VDC (supplied to base)	Voltage Input Specifications
Operating Temperature	0° to 60°C (32° to 140°F)	Voltage Ranges
Storage Temperature	-20° to 70°C (-4° to 158°F)	Resolution
Relative Humidity	5 to 95% (non-condensing)	Full Scale Calibration Error (Offset error Included)
Environmental Air	No corrosive gases permitted	Offset Calibration Error
Vibration	MIL STD 810C 514.2	Linearity Error (End to End)
Shock	MIL STD 810C 516.2	Maximum Inaccuracy
Noise Immunity	NEMA ICS3-304	NOTE 1: Terminate shields at the respective signal source NOTE 2: Leave unused channels open (no connection) *Thermocouple type is selected by setting internal jumpers NOTE 3: This module is not compatible with the ZIPLink wiring system.

Thermocouple Input Wiring Diagram

Voltage Input Wiring Diagram

Note 3: When using 0-156mV and 5V ranges, connect CH-terminal to Com or 0V terminal to ensure common mode range acceptance. Also, connect any unused channels to Com or 0V terminal.



Temperature Input Modules

F4-08THM-n 8-Channel Thermocouple Input <--->																																		
When you order the module, replace the "n" with the type of Thermocouple needed. For example, to order a Type J thermocouple module, order part number F4-08THM-J or part number F4-08THM-K for a Type K module.																																		
Number of channels	8, differential inputs																																	
Input Ranges	<table border="0"> <tr> <td>Type B</td> <td>529/1820°C</td> <td>984/3308°F</td> </tr> <tr> <td>Type C</td> <td>65/2320°C,</td> <td>149/4208°F</td> </tr> <tr> <td>Type E</td> <td>270/1000°C,</td> <td>-450/1832°F</td> </tr> <tr> <td>Type J</td> <td>-210/760°C,</td> <td>-350/1390°F</td> </tr> <tr> <td>Type K</td> <td>-270/1372°C,</td> <td>-450/2502°F</td> </tr> <tr> <td>Type R</td> <td>0/1768°C,</td> <td>32/3214°F</td> </tr> <tr> <td>Type S</td> <td>0/1768°C,</td> <td>32/3214°F</td> </tr> <tr> <td>Type T</td> <td>-270/400°C,</td> <td>-450/752°F</td> </tr> <tr> <td></td> <td>-1: 0-50 mV</td> <td></td> </tr> <tr> <td></td> <td>-2: 0-100 mV</td> <td></td> </tr> <tr> <td></td> <td>-3: 0-25mV</td> <td></td> </tr> </table>	Type B	529/1820°C	984/3308°F	Type C	65/2320°C,	149/4208°F	Type E	270/1000°C,	-450/1832°F	Type J	-210/760°C,	-350/1390°F	Type K	-270/1372°C,	-450/2502°F	Type R	0/1768°C,	32/3214°F	Type S	0/1768°C,	32/3214°F	Type T	-270/400°C,	-450/752°F		-1: 0-50 mV			-2: 0-100 mV			-3: 0-25mV	
Type B	529/1820°C	984/3308°F																																
Type C	65/2320°C,	149/4208°F																																
Type E	270/1000°C,	-450/1832°F																																
Type J	-210/760°C,	-350/1390°F																																
Type K	-270/1372°C,	-450/2502°F																																
Type R	0/1768°C,	32/3214°F																																
Type S	0/1768°C,	32/3214°F																																
Type T	-270/400°C,	-450/752°F																																
	-1: 0-50 mV																																	
	-2: 0-100 mV																																	
	-3: 0-25mV																																	
Resolution	12 bit (1 in 4,096)																																	
Input Impedance	27KΩ																																	
Absolute Maximum Ratings	Fault protected input, 130 Vrms or 100VDC																																	
Cold Junction Compensation	Automatic																																	
Conversion Time	15ms per channel, minimum 1 channel per CPU scan																																	
Converter Type	Successive Approximation, 574																																	

Linearity Error	± 1 count (0.03% of full scale) maximum
Full Scale Calibration Error	± 0.35% of full scale
Maximum Inaccuracy*	± 1°C for type E, J, K, and T ± 3°C for type B, C, R, and S
PLC Update Rate	1 ch. per scan min., 8 per scan max.
Digital Input Points Required	16 (X) input points (12 binary data bits, 3 channel ID bits, 1 sign bit)
Base Power Required 5V	120mA
Terminal Type (included)	Non-removable
External Power Supply	24VDC ±10%, 50mA current
Operating Temperature	32 to 140°F (0 to 60°C)
Storage Temperature	-4 to 158°F (-20 to 70° C)
Accuracy vs Temperature*	57 ppm/°C maximum full scale
Relative Humidity	5 to 95% (non-condensing)
Environmental Air	No corrosive gases permitted
Vibration	MIL STD 810C 514.2
Shock	MIL STD 810C 516.2
Noise Immunity	NEMA ICS3-304

Note 1: Terminate shields at the respective signal source
 Note 2: Leave unused channels open (no connection)
 Note 3: This module is not compatible with the ZIPLink wiring system.

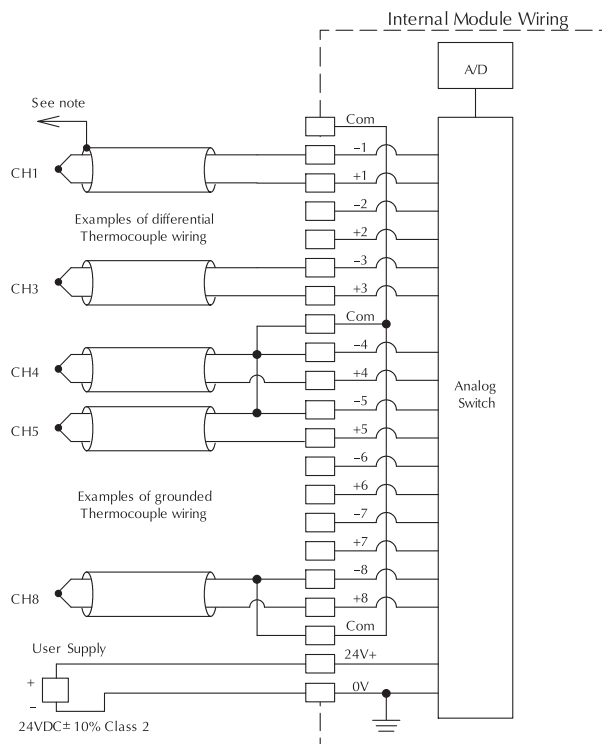

*Max. inaccuracy is not guaranteed for temperatures lower than:
 -220°C for types E & T
 -200°C for types J & K
 +100°C for types R & S

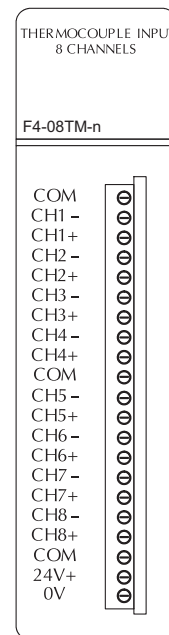

Temperature Input Modules

F4-08RTD 8-Channel RTD Input <--->	
Number of Channels	8
Input Ranges	Type Pt100: -200/850°C, -328/1562°F Type Pt1000: -200/595°C, -328/1103°F Type jPT100: -38/450°C, -36/842°F Type CU-10/25W: -200/260°C, -328/500°F
Resolution	16 bit (1 in 65535)
Input Impedance	27K Ω
Display Resolution	± 0.1°C, ±0.1°F (±3276.7)
RTD Excitation Current	200µA
Input Type	Differential
Notch Filter	>100db notches at 50/60Hz -3db=13.1 Hz
Maximum Settling Time	100msec (full-scale step input)
Common Mode Range	0-5 VDC

Absolute Maximum Ratings	Fault protected inputs to ±50 VDC
Converter Type	Charge Balancing
Linearity Error	± 1°C maximum, ±0.1°C typical
Full Scale Calibration Error	± 1°C
PLC Update Rate	1 ch. per scan min., 8 per scan max.
Digital Input Points Required	32 (X) input points (15 binary data bits, 3 channel ID bits, 1 sign bit, 8 fault bits)
Base Power Required 5V	80mA @ 5VDC
Terminal Type (included)	Removable (D4-16IOCON)
Operating Temperature	32° to 140°F (0 to 60°C)
Storage Temperature	-4 to 158°F (-20 to 70° C)
Relative Humidity	5 to 95% (non-condensing)
Environmental Air	No corrosive gases permitted
Vibration	MIL STD 810C 514.2
Shock	MIL STD 810C 516.2
Noise Immunity	NEMA ICS3-304

Notes:
 1. The three wires connecting the RTD to the module must be the same type and length. Do not use the shield or drain wire for the third connection.
 2. If an RTD sensor has 4 wires, the plus sense wire should be left unconnected as shown.

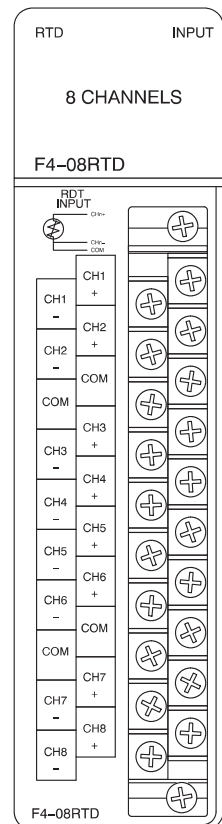
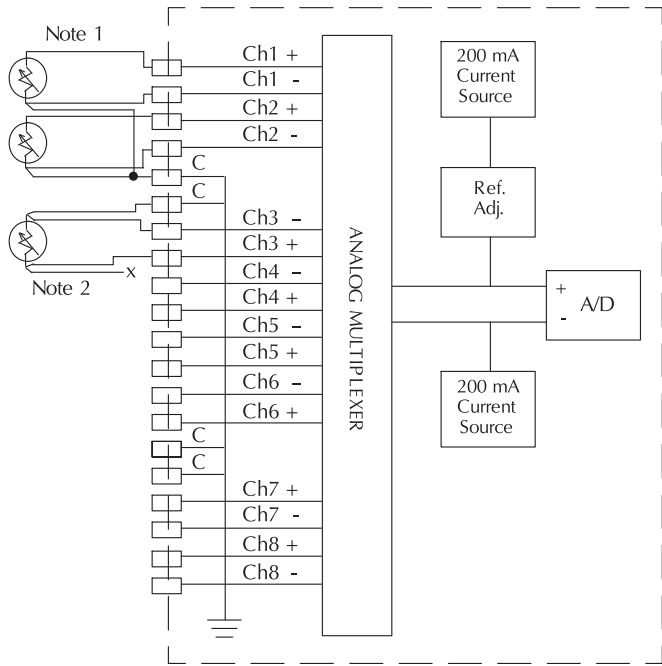

- PLC Overview
- DL05/06 PLC
- DL105 PLC
- DL205 PLC
- DL305 PLC
- DL405 PLC**
- Field I/O
- Software
- C-more HMIs
- Other HMI
- AC Drives
- Motors
- Steppers/Servos
- Motor Controls
- Proximity Sensors
- Photo Sensors
- Limit Switches
- Encoders
- Current Sensors
- Pushbuttons/Lights
- Process
- Relays/Timers
- Comm.
- TB's & Wiring
- Power
- Circuit Protection
- Enclosures
- Appendix
- Part Index