

MODEL TYPE

- VLM-635-09 LPA / VLM-635-09 LPT
- VLM-650-09 LPA / VLM-650-09 LPT

OUTLINE DIMENSIONS (UNITS: mm)

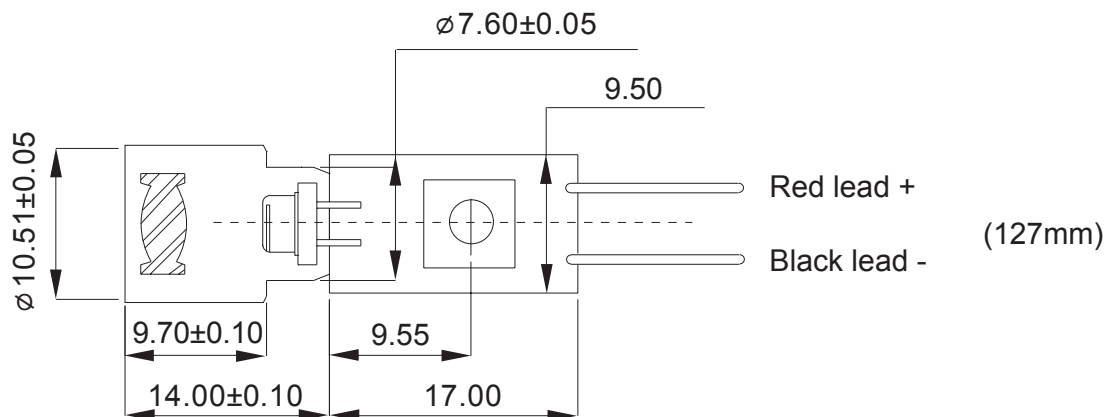

1. Basic model for general laser sighting applications.
2. This model integrated optic, laser diode into a patented solid zinc alloy structure for the most economical and the choice of laser pointer applications
3. Provides an adjustable focus function by request.
4. With a built-in switch on the PCB.
5. Options: Connection type: Spring / Lead wire (Spring type: by order).
Output power: Class II - less than 1mW / Class IIIa - less than 5mW.
6. E.S.D. protection 15KV.

SPECIFICATIONS	635-09	650-09
Operating voltage (Vop) □	3 ~ 5V	
Operating current (Iop) □	40±15mA	
Cw output power (Po)	≤ 3mW	
Wavelength at peak emission (λ p)	630 ~ 645nm	645 ~ 665nm
Collimating lens □	Aspherical plastic (φ7)	
Housing □	Zinc alloy	
Spot size at 5m □	6±2mm	
Divergence □	1.6 mrad	
Mean time to failure (MTTF) 3mW 25°C □	5000 hrs	10000 hrs
Operating temp. range □	+10°C ~ +40°C	
Storage temp. range □	-20°C ~ +65°C	