

Mechanicals Dimensions

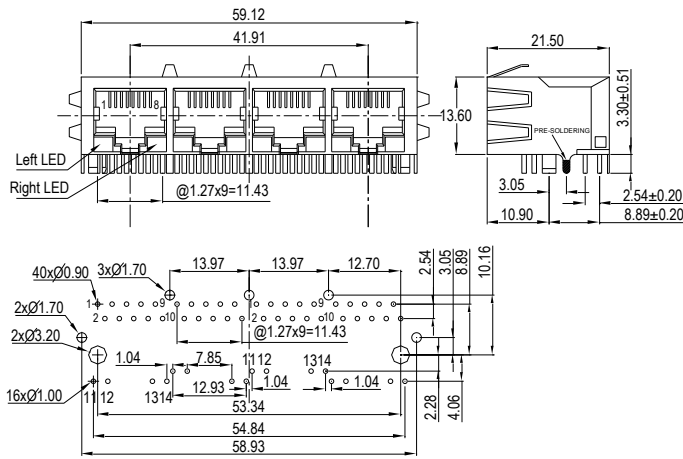

UNIT: mm Unless otherwise specified, all tolerances are ±0.25

Schematics

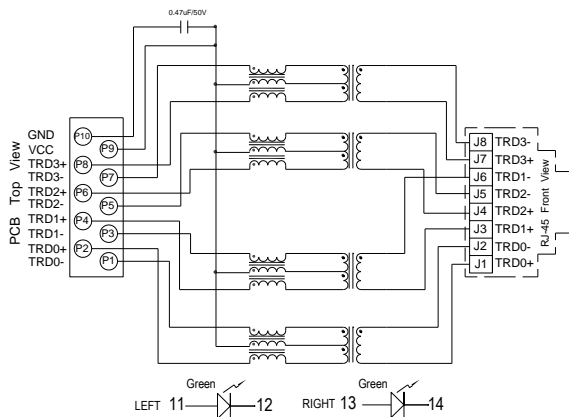

REV.	DESCRIPTION	DATE	DWN	AP'PD

ELECTRICAL SPECIFICATIONS @25°C:

1. Turns Ratio(±5%): 1CT:1
2. Inductance (100KHz/0.1V@8mA):350uH MIN
3. Insertion Loss(dB TYP): -1.0dB(1-100MHz)
4. Return Loss(dB TYP):-20dB(1-10MHz),-16dB(30MHz),-12dB(60-80MHz)
5. Cross talk (dB TYP):-40dB(1-10MHz),-35dB(30-60MHz),-30dB(60-100MHz)
6. CMR(dB TYP): -30dB(1-125MHz),-20dB(125-500MHz)
7. HI-POT:1500Vrms/0.5mA/60Sec or 1650Vrms/0.5mA/2Sec
8. Operating Temperature:0°C TO +70°C

 PREMIER MAGNETICS Tel: 949-452-0511. www.premiermag.com	
TITLE	10/100/1000 Base-T RJ45 1x4 Tab-UP
P/N	RJ64-1328GGD2
PAGE NO	1-4
AP'PD	Peter Pham
REV.	0
DATE	06/04/2009
DWN	Huu Anh

RoHS
Compliant

Mechanicals

Housing Material:

MATERIAL: NYLON GF (Fr50) UL94V-0 STANDARD COLOR: BLACK

Insert Material:

MATERIAL: Phos-Bronze C5210 EH---0.35mm Thickness

Insert -PBT GF UL94V-0

1. PLATING(1) NICKEL
2. PLATING(2) 100% Sn
3. PLATING(3) GOLD (3u " ~ 50u ")

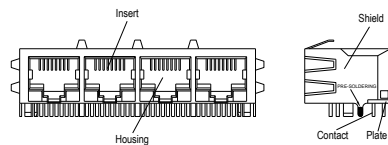

Plate Material:

PBT GF UL 94V-0

Contact pin Material:

MATERIAL: Phos-Bronze C5191 EH---0.35mm Thickness

1. PLATING(1) NICKEL
2. PLATING(2) 100% Sn

Shielding Material:

BRASS C2680 H.---0.25mm THICKNESS PLATING NICKEL

Operating Life: 750 Cycles MIN.

Environmental

1. Storage Temp: -40°C TO +85°C.
2. Operating Temp: 0°C TO +70°C.
3. MATES WITH MODULAR PLUG CONFORMING TO FCC PART 68, SUBPART F.

Part Number

REV.	DESCRIPTION	DATE	DWN	AP'PD

Packaging

1. packaging unit : 20 PCS/tray
2. packaging material : PET

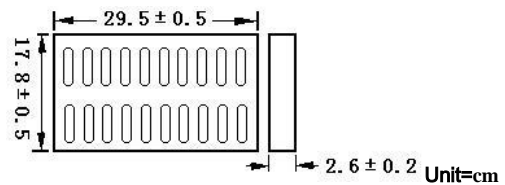

3. outer carton unit : 400 pcs/ 20 Trays/box

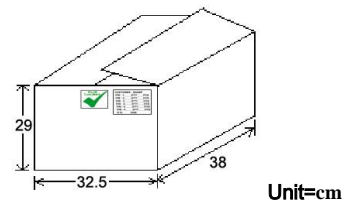

	PREMIER MAGNETICS Tel: 949-452-0511. www.premiermag.com	
	TITLE	10/100/1000 Base-T RJ45 1x4 Tab-UP
	P/N	RJ64-1328GGD2 REV. 0
	PAGE NO	2-4 DATE 06/04/2009
	AP'PD	Peter Pham DWN Huu Anh

RJ PLUG SPECIFICATION

REV.	DESCRIPTION	DATE	DWN	AP'PD

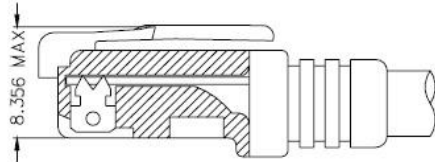
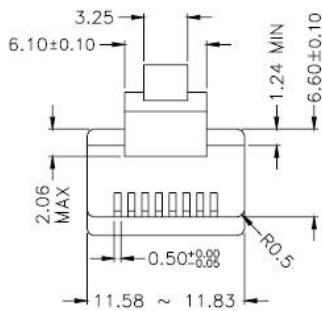

FOLLOW SPECIFICATION : FCC, PART 68, SUBPART F
FIGURE 68.500 (C)(2)(ii)

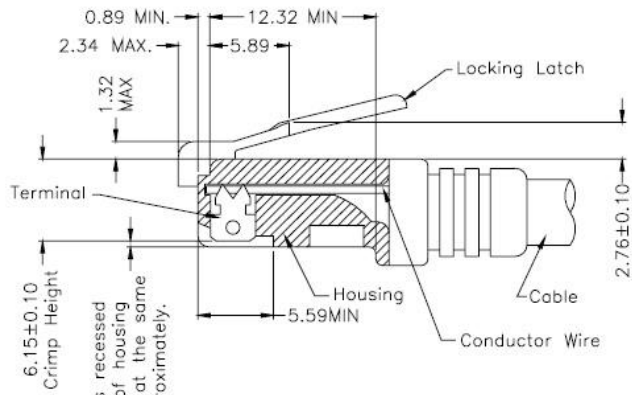

All contacts recessed below top of housing and must be at the same height approximately.

FOLLOW SPECIFICATION : FCC, PART 68,
SUBPART F FIGURE 68.500 (C)(2)(i)
AND IEC 603-7 FIGURE 23 & 24

STANDARD MODULAR PLUG ASSEMBLY

	PREMIER MAGNETICS Tel: 949-452-0511. www.premiermag.com	
	TITLE	10/100/1000 Base-T RJ45 1x4 Tab-UP
	P/N	RJ64-1328GGD2 REV. 0
	PAGE NO	3-4 DATE 06/04/2009
	AP'PD	Peter Pham DWN Huu Anh

REV.	DESCRIPTION	DATE	DWN	AP'PD

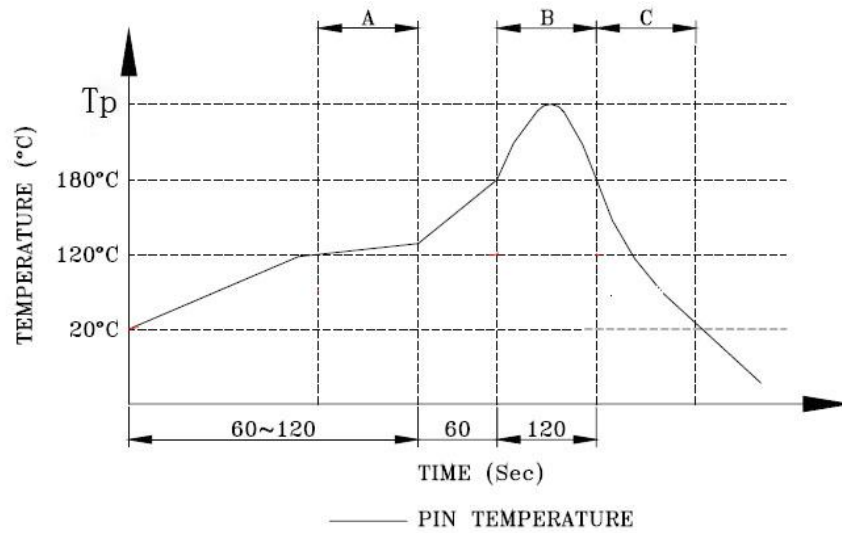

PROFILE OF WAVE SOLDER



A. Preheating B. Soldering C. Gradual Cooling

SUGGESTED WAVE SOLDER CURVER

1. Peak temperature(T_p) : $250 \pm 10^\circ\text{C}$
2. Peak temperature(T_p) time : 5sec max

	 PREMIER MAGNETICS Tel: 949-452-0511. www.premiermag.com	
	TITLE 10/100/1000 Base-T RJ45 1x4 Tab-UP	
	P/N	RJ64-1328GGD2 REV. 0
	PAGE NO	4-4 DATE 06/04/2009
	AP'PD	Peter Pham DWN Huu Anh