



**NOVATEK**  
聯詠科技

# *Data Sheet*

## ***NT39016 D***

**One Chip TFT LCD Driver IC with Timing Controller  
For S960xG240 TFT LCD**

V0.7  
Preliminary Spec.

**Revise History**

<b>NT39016 Specification Revision History</b>			
<b>Version</b>	<b>Content</b>	<b>Page</b>	<b>Date</b>
<b>0.7</b>	<b>Modify DC Electrical Characteristics</b>	<b>29 · 28</b>	<b>2008/3/10</b>
0.6	Modify pin description	8	2008/2/18
	Remove CPMPDB function	14	
0.5	Modify Analog Supply Voltage	29	2008/2/4
0.4	Modify 3-Wire Control Register	12	2008/1/14
0.3	Modify STBYB initial value	14	
	Modify Digital Operating Current value	28	2007/11/26
	Modify Analog Operating Current value	29	
0.2	Source Driver Output Timing Diagram	33	2007/11/16
0.1	New Spec.	--	2007/10/22

**NOVATEK CONFIDENTIAL  
DO NOT DISCLOSE**

## Index

Revise History .....	2
Index .....	3
Features .....	4
General Description .....	4
Function Block Diagram .....	5
System Block Diagram .....	5
Charge Pump Circuit Block Diagram .....	6
Pad Sequence (Bump Side) .....	7
Pad Description .....	8
3-Wire Serial Port Interface (Default Register Map) .....	11
3-Wire Command Format .....	11
3-Wire Control Registers (Default) .....	12
3-Wire Registers Function Description .....	14
Function Description .....	23
Power On/Off Sequence .....	23
External Reset (RSTB) .....	23
Input Data VS Output Voltage .....	24
Input Data and Output Voltage Reference Table (VSET = "0") .....	25
Data Input Format .....	26
1. RGB input Data format .....	26
2. YUV input Data format .....	26
3. CCIR_656 Mode Data format .....	26
4. Data Active Area .....	26
5. YUV_601/656 to RGB conversion .....	27
6. Brightness / Contrast Adjustment .....	27
Absolute Maximum Ratings .....	28
DC Electrical Characteristics .....	28
AC Electrical Characteristics .....	30
Timing Table .....	31
CCIR601 Mode A/B * .....	31
CCIR656 Mode A/B * .....	31
8 Bit RGB 960 CH Mode .....	31
24 Bit RGB Mode (@ SEL[3:0] = 1100 or 1101) .....	31
Timing Diagram .....	32
Clock and Data Input Timing Diagram .....	32
3-Wire Timing Diagram .....	32
Source Driver Output Timing Diagram .....	33
Gate Driver Output Timing Diagram .....	33
Vertical Timing Diagram (HV Mode) .....	34
Vertical Timing Diagram (DE Mode) .....	34
Input Data Timing (24 bit RGB mode for 960 x 240 @ SEL[3:0] = 1100b) .....	39
Pad Location .....	36
Alignment Mark .....	37
Pad Information .....	37
Application Notes .....	38
PWM for LED Backlight Control .....	38
Appendix A: Pad Coordinate .....	39

## Features

- One-Chip solution for 960 x 240 dot TFT LCD Driver
- 8-bit resolution 256 gray scale with Dithering
- Support 8-bit / 24-bit digital (RGB) or CCIR\_601/656 input timing
- Support two sets of 3-Wire commands for internal parameters setting
- Build-In DC2DC power supplies (VGH/VGL/VCOMAC/VCOMDC voltage supply)
- Configurable color filter type for both Delta and Stripe type
- 3.0 ~ 3.6V digital supply voltage with Build-In 1.8V LDO for internal circuit
- 3.0 ~ 3.6V charge pump supply voltage
- Configurable VCOMAC : 4.6V~6.1V
- Configurable VCOMDC : 1.0V~2.26V
- Source output deviation: 20mV(max)
- Source output settling time: 30uS(max)
- Operating frequency: 30MHz(max)
- Right/Left shift, Up and Down scan function selectable
- Support VCOM swing driving output
- Support Cs on Common structure
- Build-In PWM circuit for LED Back-light
- Support stand-by mode for low power consumption
- Frame / One Line / Two Line Inversion driving method selectable
- Built-in Auto Test Pattern
- COG package

## General Description

NT39016 is a single-chip solution for 960x240 dot color TFT-LCD panel, which integrated source driver, gate driver, timing controller, power generator and 3-wire interface for system function control.

With highly integration technology, NT39016 integrate 960 channels source driver and 240 channels gate driver on single silicon. Data Input support 8 bit digital image data with standard CCIR601/656, serial 8-bit RGB data format or parallel 24-bit RGB data format. Source outputs support 8-bit resolution (256 gray scales) with dithering function on. Custom parameters can be set by using 3-wire commands. Special circuit architecture is designed for system lower power dissipation.

NT39016 is designed for wide voltage supply range and small output deviation for better display quality. Power dissipation for internal 5 sections reference voltage resistors for 64-level gamma resistors are also concerned. Supporting multiple input timings make this chip more suitable to various applications of small size TFT-LCD panel.

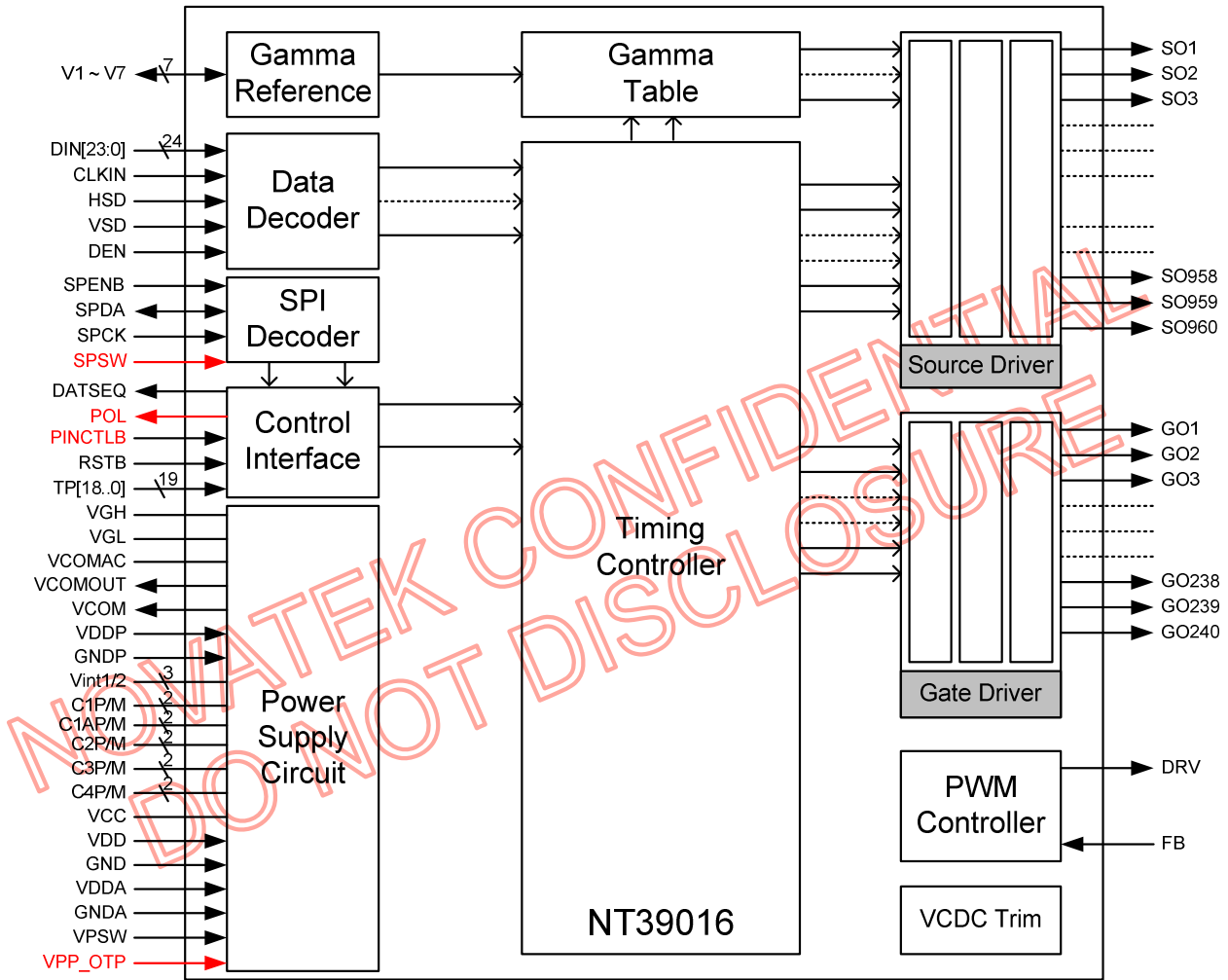
**Function Block Diagram**
**System Block Diagram**

### Charge Pump Circuit Block Diagram

NT39016 built in charge pump circuit for gate driver VGH / VGL voltage and panel VCOMAC/VCOMDC voltage. Following block diagram illustrate how the charge pump circuit works.

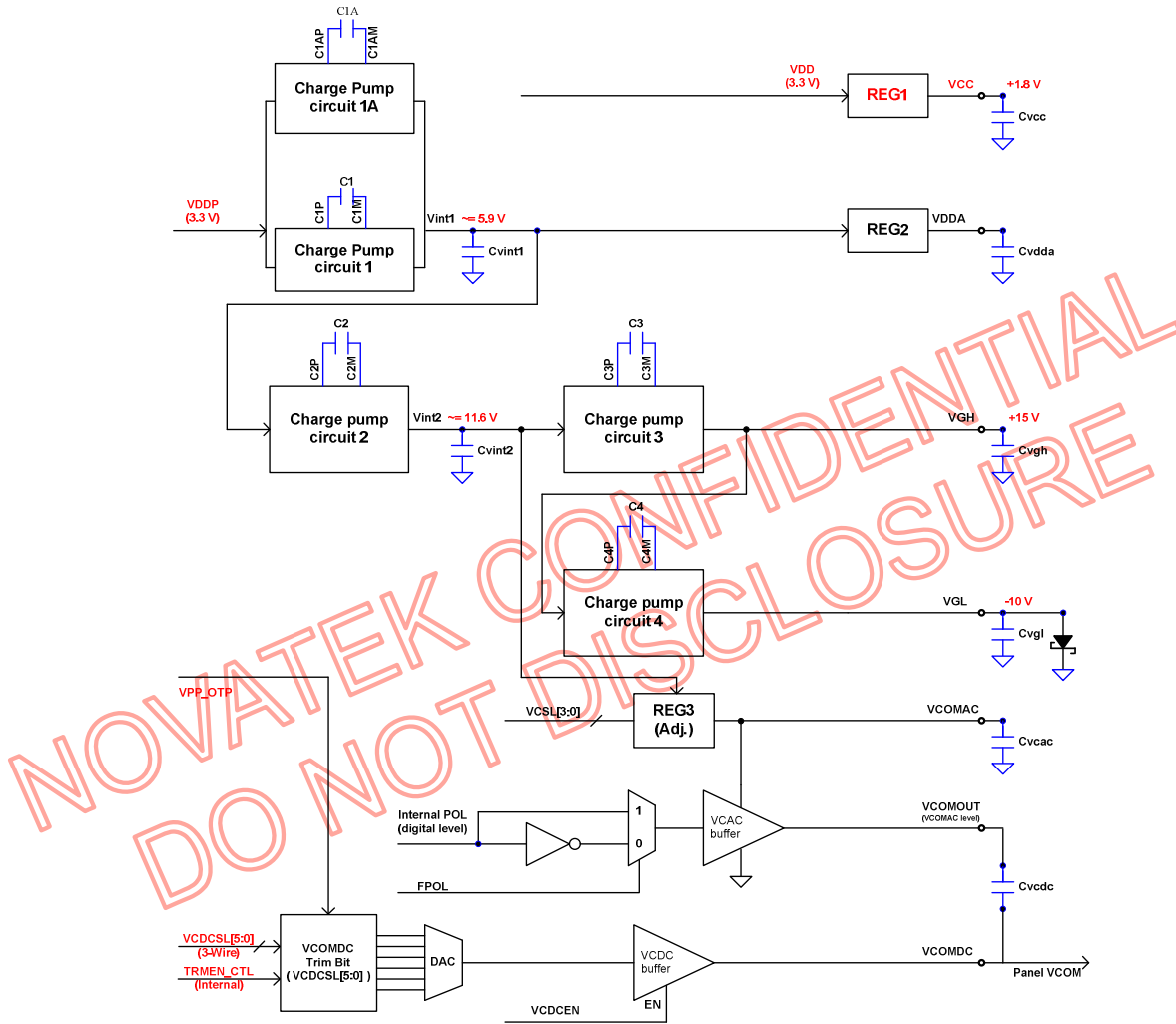

#### <Value of wiring resistance and Cap.>

Pin name	Resistor of wiring (ohm)	Cap no.	CAP (uF)
C1P	< 10	C1	≥1uF
C1M	< 10		
C2P	< 10	C2	
C2M	< 10		
C3P	< 10	C3	
C3M	< 10		
C4P	< 10	C4	
C4M	< 10		
C1AP	< 10	C1A	
C1AM	< 10		

**\*Note: Others Cap. Suggest value ≥ 4.7 uF  
Schottky diode turn-on voltage=0.2V**

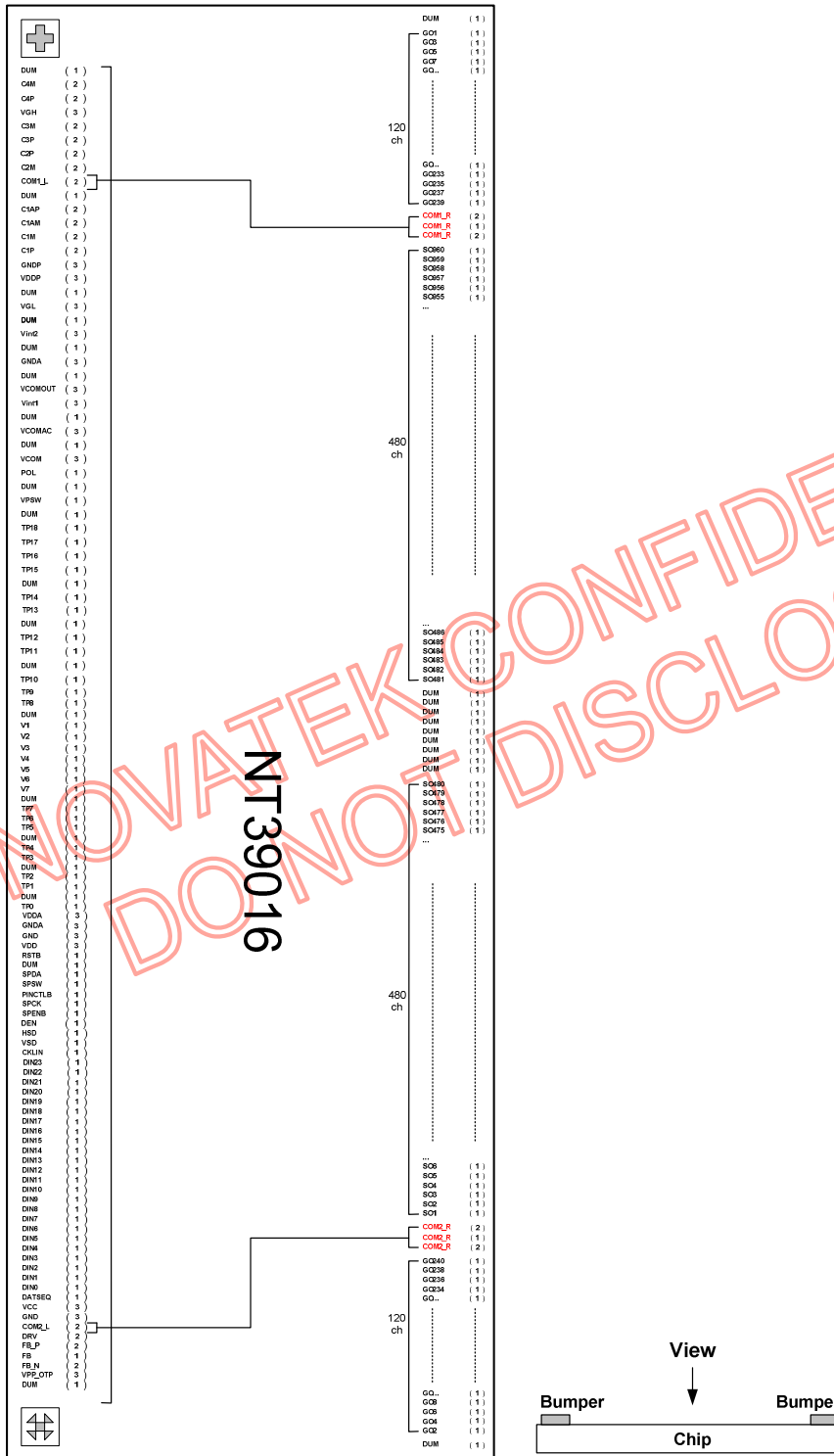
**Pad Sequence (Bump Side)**

## Pad Description

### NT39016 Pad Description:

Designation	I/O	Description
DIN[23..0]	I	Data Input. For 8/24-bit digital (RGB) or 8-bit CCIR601/656 image data input 8-bit mode: DIN7: MSB; DIN0: LSB; the remainder should be connect to GND. 24-bit mode: DIN[7:0] = R[7:0] data; DIN[15:8] = G[7:0] data; DIN[23:16] = B[7:0] data. For 18bit RGB interface, connect two LSB bits of all the R/G/B data bus to GND.
CLKIN	I	Clock for Input Data. Data latched at rising/falling edge of this signal. Default Negative polarity.
HSD	I	Horizontal Sync input. Default Negative polarity, can be change by HSDPOL register.
VSD	I	Vertical Sync input. Default Negative polarity, can be change by VSDPOL register.
DEN	I (Pull Low)	Data Input Enable. Active High to enable the data input Bus under "DE Mode". Normally pull low.
DATSEQ	O	Data sequence control pin for external T-CON. Output "1": for Odd line, "0": for Even line
POL	O	Frame polarity output. Amplitude of signal is from 0V to 3.3V.
V1 ~ V7	I/O	Gamma correction reference voltage. When VSET="1" is used. The voltage of pins V1 ~ V7 must be swing and must be AVDD-0.1V > V1 > V2 > V3    V5 > V6 > V7 > AGND+0.1V when POL="1" and AGND+0.1V < V1' < V2' < V3'    V5' < V6' < V7' < AVDD-0.1V when POL="0", Where V1-V2=V2'-V1', V2-V3=V3'-V2', ... V5-V6=V6'-V5', V6-V7=V7'-V6'. Note: V1~V7 must be supplied voltage external when VSET="1". Vx is external power of positive polarity and Vx' is external power of negative polarity
SPENB	I (Pull High)	3-Wire Communication Enable. Active Low. Normally pull high. <b>Please pull high or floating under PINCTLB=0 mode.</b>
SPDA	I/O	3-Wire Communication Data input/output.
SPCK	I	3-Wire Communication Clock input. Rising edge latch.
SPSW	I (Pull Low)	3-Wire register map select. "0" for default 3-Wire register map, "1" for optional 3-Wire register map.
RSTB	I (Pull High)	Global reset pin. Active Low to enter Reset State. Suggest connecting with a RC reset circuit for stability. Normally pull high.
PINCTLB	I (Pull High)	Enable pin control function. Normally pull high PINCTLB = "0", Enable pin control function. TP0~14 and TP16~18 active as input pin for function control propose. Refer to the TP0~18 description for more information. PINCTLB = "1", Default mode. TP0~14 and TP16~18 active as unknown state ; Don't connect TP0~14 and TP16~18 to any state under this mode. <b>Note: The 3-wire control register will be disabled under PINCTLB = 0 mode.</b>
SO1~SO960	O	Source Driver Output Signals.
GO1~GO240	O	Gate Driver Output Signals.
ALIGN_T/B	M	For assembly alignment.
TP15	I	Charge pump on/off control pin. TP15=CPMPDB CPMPDB = "0", internal charge pump will be shut down CPMPDB = "1", internal charge pump normal operating TP15 active as input pin under any state of PINCTLB. If floating TP15, the charge pump will turn off
TP0~14 TP16~18	T I	TEST Pin / Function control pin. When PINCTLB = "1", TP0~14, TP16~18 act as test pin. Floating those pins for normal operation. When PINCTLB = "0", TP0~14, TP16~18 act as function control input pin. All the input pin should be connect to GND or VDD. Floating those pins will result in input unknown problem.
VPSW	I (Pull Low)	Voltage control switch. Normally pull low. VPSW = "0". Default mode. VGH · VGL · VCOMAC and VCOMDC active as normal use and control by 3-wire. VPSW = "1". Voltage fix mode. VGH = 18V · VGL = -7V · VCOMAC = 5.4V and VCOMDC



		= 1.7V. Under the mode voltage can't control by 3-wire
VPP_OTP	P	Customer OTP power input pin
VGH	PS	Capacitor pin. Positive power supply for Gate Driver output
VGL	PS	Capacitor pin. Negative power supply for Gate Driver output
VCOMAC	PS	Capacitor pin. Power supply for VCOMOUT output
VCOM	PS	VCOM DC voltage output pin for DC re-construction
VCOMOUT	O	Frame polarity output for panel VCOM. Amplitude of signal is from GNDA1 to VDDA1 The polarity of VCOMOUT is inversed with internal signal "POL" when "FPOL" = 0
VDDA	PO	Power supply for source driver and gamma circuit
GNDA	PI	Ground pins for source driver and gamma circuit
VDD	PI	Power supply for digital circuits
GND	PI	Ground pins for digital circuits
VDDP	PI	Power supply for charge pump circuits
GNDP	PI	Ground pins for charge pump circuits
VCC	C	Capacitor connect pin for internal regulator Refer to the section of "Power Circuit" for the application.
C1P/M C1AP/M C2P/M C3P/M C4P/M Vint1/2	C	Capacitor connect pin for internal charge pump Refer to the section of "Power Circuit" for the application.
FB_P	I	Internal power switch current input pad. <b>Note: Voltage on this pad should be &lt; 5.5V. Pull low in more than one LED case.</b>
FB_N	O	Internal power switch current output pad. <b>Note: Voltage on this pad should be &lt; 5.5V. Pull low in more than one LED case.</b>
FB	VI	PWM controller feedback input. FB threshold is 0.6 V nominal
DRV	O	PWM output driver signal for the boost converter
COM1_L/R	S	The internal link together between input side and Output side.
COM2_L/R	S	The internal link together between input side and Output side.
<b>DUM</b>	<b>D</b>	<b>Don't connect to any signal or pull high/low.</b>

**Note:**

I: Input, O: Output, P: Power, D: Dummy, S: Shorted line, M: Mark, PI: Power input, PO: Power output, T: Testing  
I/ O: Input / Output, PS: Power Setting, C: Capacitor pin.

**NT39016 Align Mark:**

ALIGN_T	M	For assembly alignment.
ALIGN_B	M	For assembly alignment.

**NT39016 Pass Line Description:**

Pass Line No:	Pad Name	
1	COM1_L	COM1_R
2	COM2_L	COM2_R

**TP0 ~ TP14 and TP16~TP18 Function Control Pin Mapping Table (When PINCTLB = "0"):**

TPx	PINCTLB = "0"
	Input control function (Related to 3-wire control register)
0	STBYB
1	UPDN
2	SHLR
3	SEL0
4	SEL1
5	SEL2
6	SEL3
7	FRAD0
8	FRAD1
9	PAL
10	PALM
11	SKIPMOD
12	HDNC0
13	HDNC1
14	FPOL
16	PWMPDB
17	AVGY
18	Auto Test Pattern Enable

Note 1: PINCTLB function has higher priority than the 3-wire command. The 3-wire control register will be disabled when PINCTLB = "0". **Please pull high or floating SPENB under PINCTLB=0 mode.**

**Remark:**

TP15=CPMPDB · Charge pump on/off control pin.  
 CPMPDB = "0", internal charge pump will be shut down  
 CPMPDB = "1", internal charge pump normal operating  
 TP15 active as input pin under any state of PINCTLB.

### 3-Wire Serial Port Interface (Default Register Map)

#### 3-Wire Command Format

NT39016 uses the 3-wire serial port as communication interface for all the function and parameter setting. 3-Wire communication can be bi-directional controlled by the "R/W" bit in address field. NT39016 3-Wire engine act as a "slave mode" for all the time, and will not issue any command to the 3-Wire bus itself. Under read mode, 3-Wire engine will return the data during "Data phase". The returned data should be latched at the rising edge of SPCK by external controller. Data in the "Hi-Z phase" will be ignored by 3-Wire engine during write operation, and should be ignored during read operation also. During read operation, external controller should float SPDA pin under "Hi-Z phase" and "Data phase". Refer to the section of "3-Wire Timing Diagram" for the detail timing, please.

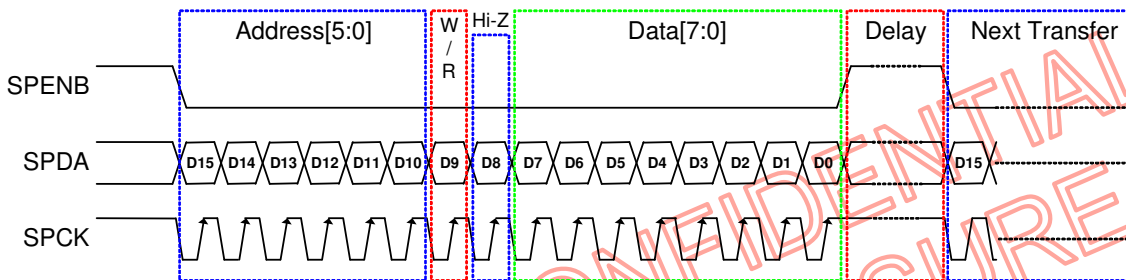

#### 3-Wire Command Format:

Bit	Description
D15-D10	Register Address [5:0].
D9	W/R control bit. "1" for Write; "0" for Read
D8	Hi-Z bit during read mode. Any data within this bits will be ignored during write mode
D7-D0	Data for the W/R operation to the address indicated by Address phase

#### 3-Wire Writer Format:

MSB															LSB
D15	D14	D13	D12	D11	D10	D9	D8	D7	D6	D5	D4	D3	D2	D1	D0
Register Address [5:0]						1	X	DATA (Issue by external controller)							

#### 3-Wire Read Format:

MSB															LSB
D15	D14	D13	D12	D11	D10	D9	D8	D7	D6	D5	D4	D3	D2	D1	D0
Register Address [5:0]						0	Hi-Z	DATA (Issue by NT39016)							

### 3-Wire Control Registers (Default)

Following table list the default 3-Wire control registers and bit name definition for NT39016. Refer to the next section for detail register function description, please.

**NT39016 3-Wire Control Register List (Default)**

3-Wire Registers		Register Description		
D[15:10]	Name	Init.	R/W	Function Description
000000b	R00	07h	R/W	System control register
000001b	R01	00h	R/W	Timing Controller function register
000010b	R02	03h	R/W	Operation control register
000011b	R03	CCh	R/W	Input data Format control register
000100b	R04	46h	R/W	Source Timing delay control register
000101b	R05	0Dh	R/W	Gate Timing delay control register
000110b	R06	00h	R/W	Reserved
000111b	R07	00h	R/W	Internal function control register
001000b	R08	08h	R/W	RGB Contrast control register
001001b	R09	40h	R/W	RGB Brightness control register
001010b	R0A	88h	R/W	Hue / Saturation control register
001011b	R0B	88h	R/W	R / B Sub-Contrast control register
001100b	R0C	20h	R/W	R Sub-Brightness control register
001101b	R0D	20h	R/W	B Sub-Brightness control register
001110b	R0E	10h	R/W	VCOMDC Level Control Register
001111b	R0F	A4h	R/W	VCOMAC Level Control Register
010000b	R10	04h	R/W	VGAM2 level control register
010001b	R11	24h	R/W	VGAM3/4 level control register
010010b	R12	24h	R/W	VGAM5/6 level control register
011110b	R1E	00h	R/W	VCOMDC Trim function control register
100000b	R20	00h	R/W	Wide and narrow display mode control register

**NT39016 3-Wire Register Bit Definition (Default)**

3-Wire Control Register Bit Map								
Reg.	Bit [7]	Bit [6]	Bit [5]	Bit [4]	Bit [3]	Bit [2]	Bit [1]	Bit [0]
R00	PAT3	PAT2	PAT1	PAT0	PWMPDB	X	STBYB	RESETB
R01	X	X	X	SWD2	SWD1	SWD0	DITHB	CFTYP
R02	SKIPMOD	HDNC1	HDNC0	X	FPOL	VSET	UPDN	SHLR
R03	DENPOL	CLKPOL	HSDPOL	VSDPOL	SEL3	SEL2	SEL1	SEL0
R04	DDLY7	DDLY6	DDLY5	DDLY4	DDLY3	DDLY2	DDLY1	DDLY0
R05	X	HDLY6	HDLY5	HDLY4	HDLY3	HDLY2	HDLY1	HDLY0
R06	X	X	X	X	X	X	X	X
R07	FRAD1	FRAD0	INVSL1	INVSL0	PAL	PALM	-	AVGY
R08	X	X	X	CON4	CON3	CON2	CON1	CON0
R09	X	BRI6	BRI5	BRI4	BRI3	BRI2	BRI1	BRI0
R0A	HUE3	HUE2	HUE1	HUE0	SAT3	SAT2	SAT1	SAT0
R0B	SCONB1	SCONB0			SCONR1	SCONR0		
R0C	X	X	SBRIR5	SBRIR4	SBRIR3	SBRIR2	SBRIR1	SBRIR0
R0D	X	X	SBRIB5	SBRIB4	SBRIB3	SBRIB2	SBRIB1	SBRIB0
R0E	X	OTP_BYPS	VCDCSL5	VCDCSL4	VCDCSL3	VCDCSL2	VCDCSL1	VCDCSL0
R0F	VGLSL1	VGLSL0	VGHSL1	VGHSL0	VCACSL3	VCACSL2	VCACSL1	VCACSL0
R10	X	X	X	GAMEN	X	V2GAM2	V2GAM1	V2GAM0
R11	X	X	V4GAM2	V4GAM1	V4GAM0	V3GAM2	V3GAM1	V3GAM0
R12	X	X	V6GAM2	V6GAM1	V6GAM0	V5GAM2	V5GAM1	V5GAM0
R1E	TRMEN7	TRMEN6	TRMEN5	TRMEN4	TRMEN3	TRMEN2	TRMEN1	TRMEN0
R20	X	X	X	X	X	X	WNSEL1	WNSEL0

Note: Register function active at the falling edge of VSD except STBYB, RESETB register bits.

**Registers require Vsync trigger table**

DITHB	CFTYP	SKIPMOD	HDNC	FPOL	VSET	UPDN	SHLR	DDLY	HDLY	FRAD	INVSL
PAL	PALM	AVGY	CON	BRI	HUE	SAT	SCONB	SCONR	SBRIR	SBRIB	

### 3-Wire Registers Function Description

#### R00: System Control Register

Bit	Name	Initial	R/W	Description
Bit [7:4]	PAT[3:0]	0000b	R/W	Internal Test Pattern Selection PAT[3:0] : Select chip embedded test pattern.
Bit [3]	PWMPDB	0b	(R) R/W	Internal PWM controller Power Down bit PWMPDB = "0", internal PWM controller will be shut down PWMPDB = "1", internal PWM controller normal operating
Bit [2]	-	-	-	Reserve
Bit [1]	STBYB	1b	(R) R/W	Standby Mode function control. STBYB = "0", TCON, Source output will turn off and outputs are High-Z. STBYB = "1", Normal operation
Bit [0]	RESETB	1b	R/W	Global Reset Register. Write "0" to reset whole chip. This bit will set to "1" automatically after chip was reset.

#### PAT[3:0] : Embedded Auto Test Pattern Selection Register

PAT[3:0]	Test Pattern	Note
00H	Disable Internal Test Pattern Function	Default
01H	White	
02H	Black	
03H	Red	
04H	Green	
05H	Blue	
06H	Yellow	
07H	Cyan	
08H	Magenta	
09H	Gray Level 8	
0AH	Gray Level 16	
0BH	Color Bar	
0CH	Checker Board	
0DH	Cross Talk Pattern	
0EH	Horizontal Flick Pattern	
0FH	Test Pattern Auto Run Mode	

Note: WNSSEL[1:0] will be disabled under Internal Test Pattern mode.

**R01: Timing Controller Function Register**

Bit	Name	Initial	R/W	Description
Bit [4:2]	SWD[2:0]	000b	R/W	Control and switch the relationship between the R,G,B and outputs. This register is used to match different types of color filters on LCD panel
Bit [1]	DITHB	0b	R/W	Dithering enable. Active low DITHB = "0", Dithering on, (Pseudo 8-bits resolution). (Default mode) DITHB = "1", Dithering off, (6-bits resolution, truncation last 2-bits of the input data) Note 1: Recommend user to enable this function under all modes except for 18 bit RGB input application.
Bit [0]	CFTYP	0b	R/W	Color Filter Type Select. Select Delta or Stripe mode for data arrangement. CFTYP = "0", Stripe mode, Data arrangement keep in the "odd line" state of SWD[2:0] selection. CFTYP = "1", Delta mode, Data arrangement controlled by SWD[2:0] setting.

**SWD[2:0] function control:**

SWD2	SWD1	SWD0	Output (n=0 to 319)				Condition
			3n+1	3n+2	3n+3		
0	0	0	R	G	B	Odd Line	SHLR="1" UPDN="1"
			G	B	R	Even Line	
0	0	1	G	B	R	Odd Line	
			B	R	G	Even Line	
0	1	X	B	R	G	Odd Line	
			R	G	B	Even Line	
1	0	0	G	B	R	Odd Line	
			R	G	B	Even Line	
1	0	1	B	R	G	Odd Line	
			G	B	R	Even Line	
1	1	X	R	G	B	Odd Line	
			B	R	G	Even Line	

Note 1: X = Don't care

Note 2: Data arrangement will keep in the "odd line" state when CFTYP = 0 for stripe mode.

**R02: Operation Control Register**

Bit	Name	Initial	R/W	Description
Bit [7]	SKIPMOD	0b	(R) R/W	Horizontal data processing algorithms select register. SKIPMOD = "0": Horizontal data weighting skip mode. (Default mode) SKIPMOD = "1": Horizontal data direct skip mode.
Bit [6:5]	HDNC[1:0]	00b	(R) R/W	Horizontal Data scaling mode select register. This function is active under CCIR601 and CCIR656 mode only.
Bit [4]	-	-	-	Reserve
Bit [3]	FPOL	0b	R/W	VCOMOUT polarity inverse control. FPOL = "0": VCOMOUT normal polarity (Default mode). FPOL = "1": VCOMOUT inverse polarity.
Bit [2]	VSET	0b	R/W	Gamma correction source select. VSET = "0", used internal Gamma Reference voltage (VDDA). (Default mode) VSET = "1", used external Gamma Reference Input (V1~V7).
Bit [1]	UPDN	1b	(R) R/W	Gate Driver Up/down scan control of gate driver. UPDN = "0", Shift from down to up, First line=L240->L239->...->L2->L1= Last line UPDN = "1", Shift from up to down, First line=L1->L2->...->L239->L240= Last line <b>(Default mode)</b>
Bit [0]	SHLR	1b	(R) R/W	Right/Left sequence control of source driver. SHLR = "0", shift left: Last data = S1 ← S2 ← S3 ..... ← S960 = First data. SHLR = "1", shift right: First data = S1 → S → S3 ..... → S960 = Last data.

**HDNC[1:0] function setting for different horizontal data skip mode**

HDNC1	HDNC0	Source Data	Data Skip Mode
0	0	1440 / 1280 clock	1440 clock -> 720 RGB -> (scale down) 320 RGB 1280 clock -> 640 RGB -> (scale down) 320 RGB
0	1	1440 clock	1440 clock -> 720 RGB -> (Skip Right/Left 10 RGB) 700 RGB -> (scale down) 320 RGB
1	0	1440 clock	1440 clock -> 720 RGB -> (Skip Right/Left 20 RGB) 680 RGB -> (scale down) 320 RGB
1	1	1440 clock	1440 clock -> 720 RGB -> (Skip Right/Left 40 RGB) 640 RGB -> (scale down) 320 RGB

**Note: HDNC function is active under CCIR601/656 mode only**

**R03: Input Data Format Control Register**

Bit	Name	Initial	R/W	Description
Bit [7]	DENPOL	1b	R/W	DEN input pin polarity control. DENPOL = "0", DEN negative polarity. DENPOL = "1", DEN positive polarity. (Default mode)
Bit [6]	CLKPOL	1b	R/W	CLKIN pin polarity control. CLKPOL = "0", CLKIN negative edge latch data. CLKPOL = "1", CLKIN positive edge latch data. (Default mode)
Bit [5]	HSDPOL	0b	R/W	HSD pin polarity control. HSDPOL = "0", HSD negative polarity. (Default mode) HSDPOL = "1", HSD positive polarity.
Bit [4]	VSDPOL	0b	R/W	VSD pin polarity control. VSDPOL = "0", VSD negative polarity. (Default mode) VSDPOL = "1", VSD positive polarity
Bit [3:0]	SEL[3:0]	1100b	(R) R/W	Input data format selection. Note: Different SEL [3:0] setting resolute in different AC timing.



**SEL[3:0]: Data input mode**

SEL3	SEL2	SEL1	SEL0	Data input format	Operating frequency
0	0	0	0	CCIR601 YUV 1280 input format (YUV mode A)	24.54 MHz
0	0	0	1	CCIR601 YUV 1280 input format (YUV mode B)	24.54 MHz
0	0	1	0	CCIR601 YUV 1440 input format (YUV mode A)	27 MHz
0	0	1	1	CCIR601 YUV 1440 input format (YUV mode B)	27 MHz
0	1	0	0	CCIR656 YCbCr input format (YcbCr mode A)	27 MHz
0	1	0	1	CCIR656 YCbCr input format (YcbCr mode B)	27 MHz
0	1	1	0	-	-
0	1	1	1	-	-
1	0	0	0	8-bit digital RGB input format HV Mode (NTSC only)	27 MHz
1	0	0	1	8-bit digital RGB input format DE Mode (NTSC only)	27 MHz
1	0	1	0	8-bit digital RGB through mode input format HV Mode (NTSC only)	27 MHz
1	0	1	1	8-bit digital RGB through mode input format DE Mode (NTSC only)	27 MHz
1	1	0	0	24-bit digital RGB input format HV Mode (NTSC only)	6.4 MHz
1	1	0	1	24-bit digital RGB input format DE Mode (NTSC only)	6.4 MHz
1	1	1	0	-	-
1	1	1	1	-	-

Note : Hsync and Vsync will be floated in CCIR656 and DE mode

Remark:

YUV mode A: Data sequence are "Cb\_Y\_Cr\_Y..."

YUV mode B: Data sequence are "Cr\_Y\_Cb\_Y..."

RGB through mode will bypass 3-wire SWD[2:0] function; TCON will not arrange data color mapping.

**R04: Source Timing Delay Control Register**

Bit	Name	Initial	R/W	Description
Bit [7:0]	DDL[7:0]	46h	R/W	Select the HSD signal to 1 <sup>st</sup> input data delay timing Under CCIR601 mode, T <sub>hs</sub> = DDL[7:0] + 128, (Unit = CLKIN) Under CCIR656 mode, T <sub>hs</sub> = DDL[7:0] + 136, (Unit = CLKIN) Under RGB 8/24 bit mode, T <sub>hs</sub> = DDL[7:0], (Unit = CLKIN) The register value will be update to the different default value each time when SEL[3:0] changed. Read the section of "Timing Table" for the detail, please.

Note: DDL function will be disabled under 8/24bit DE mode and PINCTLB = 0 condition. The default value list in the timing table will be used when PINCTLB = 0.

**R05: Gate Timing Delay Control Register**

Bit	Name	Initial	R/W	Description
Bit [7]	-	-	-	Reserve
Bit [6:0]	HDLY[6:0]	0Dh	R/W	Select the Gate start pulse output delay timing T <sub>vs</sub> = HDLY[6:0], (Unit = HSD) The register value will be update to the different default value each time when SEL[3:0] changed. Read the section of "Timing Table" for the detail, please.

Note: HDLY function will be disabled under 8/24bit DE mode and PINCTLB = 0 condition. The default value list in the timing table will be used when PINCTLB = 0.

**R06: Reserved**

Bit	Name	Initial	R/W	Description
Bit [7:0]	-	-	-	Reserve

**R07: Internal Function Control Register**

Bit	Name	Initial	R/W	Description
Bit [7:6]	FRAD[1:0]	00b	R/W	Odd frame or Even frame advance control
Bit [5:4]	INVSL[1:0]	00b	R/W	Source Driving Mode Selection Register
Bit [3]	PAL	0b	(R) R/W	NTSC or PAL mode selection. <b>Only for 601 and 656 mode.</b> PAL = "0", Select NTSC interface mode. (Default mode) PAL = "1", Select PAL interface mode.
Bit [2]	PALM	0b	(R) R/W	PAL mode input data format selection PALM = "0", Select PAL 280 line mode. (Default mode) PALM = "1", Select PAL 288 line mode
Bit [1]	-	-	-	Reserve
Bit [0]	AVGY	0b	R/W	Average YUV interface Luminance Y. AVGY = "0"; Only used odd Y sample for YUV conversion, AVGY = "1"; Used odd and even Y sample for YUV conversion. This function active under YUV mode only!

**INVSL[1:0]**

INVSL1	INVSL0	Driving Mode	Notes
0	0	1 - Line Inversion	Default
0	1	2 - Line Inversion	
1	0	Frame Inversion	
1	1	Reserved	

**FRAD[1:0]**

FRAD1	FRAD0	Advance Frame	Notes	Unit: H
0	0	Default	Odd/Even frame Tstv are the same	
0	1	Odd frame	Even frame Tstv = HDLY setting +1	
1	0	Even frame	ODD frame Tstv = HDLY setting +1	
1	1	Reserve	Reserve	

**Note: Remark: This function is available under CCIR601 and CCIR656 mode only.**

**R08: Contrast Control Register**

Bit	Name	Initial	R/W	Description
Bit [7:5]	-	-	-	Reserve
Bit [4:0]	CON[4:0]	08h	R/W	Display Contrast level adjustment register. (0.125/Step) Adjust range from 0x00(level = 0) to 0x1F(level = 3.875) Default value 08h(level = 1.0)

**R09: Brightness Control Register**

Bit	Name	Initial	R/W	Description
Bit [7]	-	-	-	Reserve
Bit [6:0]	BRI[6:0]	40h	R/W	Display Brightness level adjustment register. (2/Step) Adjust range from 0x00(level = -128) to 0x7F(level = +126) Default value 0x40(level = +0)

**R0A: Hue and Saturation Control Register**

Bit	Name	Initial	R/W	Description
Bit [7:4]	HUE[3:0]	08h	R/W	YUV Hue level adjustment register. (5 Deg/Step) Adjust range from 0x00(level = -40 Deg) to 0x0F(level = +35 Deg) Default value 0x08(level = 0 Deg) $Cb' = Cb * \cos \theta + Cr * \sin \theta$ $Cr' = Cr * \cos \theta - Cb * \sin \theta$
Bit [3:0]	SAT[3:0]	08h	R/W	YUV saturation level adjustment register. (0.125/Step) Adjust range from 0x00(level = 0) to 0x0F(level = 1.875) Default value 0x08(level = 1.00)

**Note: Hue and Saturation function was available under YUV input mode only.**

**R0B: R / B Sub-Contrast Control Register**

Bit	Name	Initial	R/W	Description
Bit [7:6]	SCONB[1:0]	02h	R/W	B Data Contrast level adjustment register. (0.125/Step) Adjust range from 0x00(level = 0.75) to 0x0F(level = 1.125) Default value 08h(level = 1.0)
Bit [3:2]	SCONR[1:0]	02h	R/W	R Data Contrast level adjustment register. (0.125/Step) Adjust range from 0x00(level = 0.75) to 0x0F(level = 1.125) Default value 08h(level = 1.0)

**R0C: R Sub-Brightness Control Register**

Bit	Name	Initial	R/W	Description
Bit [7:6]	-	-	-	Reserve
Bit [5:0]	SBRIR[5:0]	20h	R/W	R Data Brightness level adjustment register. (1/Step) Adjust range from 0x00(level = -32) to 0x3F(level = +31) Default value 20h(level = 0)

**R0D: B Sub-Brightness Control Register**

Bit	Name	Initial	R/W	Description
Bit [7:6]	-	-	-	Reserve
Bit [5:0]	SBRIB[5:0]	20h	R/W	B Data Brightness level adjustment register. (1/Step) Adjust range from 0x00(level = -32) to 0x3F(level = +31) Default value 20h(level = 0)

**R0E: VCOMDC Level Control Register**

Bit	Name	Initial	R/W	Description
Bit [7]	-	-	-	Reserve
Bit [6]	OTP_BYPS	0h	R/W	VDCSL[5:0] data source selection register OTP_BYPS = "0", VDCSL[5:0] is read from OTP memory. OTP_BYPS = "1", VDCSL[5:0] is switch to the 3-wire register memory when user want to adjust the VCOMDC level for test propose. Refer to the "TRMEN" control register for the proper OTP write operation.
Bit [5:0]	VDCSL [5:0]	10h	R/W	VCOMDC level control register (20mV/Step @ VDDA = 5.0V) VDCSL[5:0] = 00h, VCOMDC = 1.00V VDCSL[5:0] = 01h, VCOMDC = 1.02V ..... VDCSL[5:0] = 10h, VCOMDC = 1.32V ..... VDCSL[5:0] = 3eh, VCOMDC = 2.24V VDCSL[5:0] = 3fh, VCOMDC = 2.26V

Note : .VCOMDC always keep 1.7V When VPSW = "1" . The OTP value effect in VPSW=0.  
The offset value is equal to 50mV in default level

**R0F VCOMAC Level Control Register**

Bit	Name	Initial	R/W	Description
Bit [7:6]	VGLSL	10	R/W	VGLSL level control register VGLSL Level = 1V / Step
Bit [5:4]	VGHSL	10	R/W	VGHSL level control register VGHSL Level = 1V / Step
Bit [3:0]	VCACSL[3:0]	0100	R/W	VCOMAC level control register VCOMAC Level = 0.1V / Step @ VDDA = 5.0V

**VCACSL [3:0]**

VCSL3	VCSL2	VCSL1	VCSL0	Level (V)
0	0	0	0	4.6
0	0	0	1	4.7
0	0	1	0	4.8
0	0	1	1	4.9
0	1	0	0	5.0 (Default)
0	1	0	1	5.1
0	1	1	0	5.2
0	1	1	1	5.3
1	0	0	0	5.4
1	0	0	1	5.5
1	0	1	0	5.6
1	0	1	1	5.7
1	1	0	0	5.8
1	1	0	1	5.9
1	1	1	0	6.0
1	1	1	1	6.1

Note : When VPSW = "1" .The register can't be used  
The offset value is equal to 100mV in default level

**VGHSL[5:4]**

VGHSL1	VGHSL0	VGH(V)
0	0	12
0	1	13
1	1	14
1	0	15

When VPSW = "1" .The register can't be used

**VGLSL[7:6]**

VGHSL1	VGHSL0	VGL(V)
0	0	-7
0	1	-8
1	1	-9
1	0	-10

When VPSW = "1" .The register can't be used

**R10: VGAM2 Level Control Register**

Bit	Name	Initial	R/W	Description
Bit [7:5]	-	-	-	Reserve
Bit [4]	GAMEN	0b	R/W	GAMMA adjustment enable control register. (adjustable voltage for V2-V6) GAEN="0" or VSET = 1, Gamma correction disabled. GAEN="1" & VSET="0", Gamma correction enabled
Bit [3]	-	-	-	Reserve
Bit [2:0]	V2GAM [2:0]	100b	R/W	V2 GAMMA voltage level setting. Function enabled when VSET="0" Adjust level = 22mV / Step

**R11: VGAM3/4 Level Control Register**

Bit	Name	Initial	R/W	Description
Bit [7:6]	-	-	-	Reserve
Bit [5:3]	V4GAM [2:0]	100b	R/W	V4 GAMMA voltage level setting. Function enabled when VSET="0" Adjust level = 22mV / Step
Bit [2:0]	V3GAM [2:0]	100b	R/W	V3 GAMMA voltage level setting. Function enabled when VSET="0" Adjust level = 22mV / Step

**R12: VGAM5/6 Level Control Register**

Bit	Name	Initial	R/W	Description
Bit [10:6]	-	-	-	Reserve
Bit [5:3]	V6GAM [2:0]	100b	R/W	V6 GAMMA voltage level setting. Function enabled when VSET="0" Adjust level = 22mV / Step
Bit [2:0]	V5GAM [2:0]	100b	R/W	V5 GAMMA voltage level setting. Function enabled when VSET="0" Adjust level = 22mV / Step

**V2GAM/ V3GAM/ V4GAM/ V5GAM./ V6GAM Level Control Register Setting Table**

VxGMA2	VxGMA1	VxGMA0	Voltage level	Unit	Note
0	0	0	+88	mV	Refer to the Gamma Table for the default voltage level of V2 ~ V6
0	0	1	+66	mV	
0	1	0	+44	mV	
0	1	1	+22	mV	
1	0	0	+0(Default)	mV	
1	0	1	-22	mV	
1	1	0	-44	mV	
1	1	1	-66	mV	

Note: x = 2, 3, 4, 5, 6

**R1E: VCOMDC Trim Function Control Register**

Bit	Name	Initial	R/W	Description
Bit [7:0]	TRMEN [7:0]	00b	R/W	VCOMDC Trim function control register Write the follow command sequentially to enable the VCOMDC trim function. Adjust VCDC level: Set TRMEN[7:0]=00h and write proper VCDCSL[5:0] value using 3-wire cmd. Programming the VCDCSL value into OTP memory: Set TRMEN[7:0] as following sequence A0h->5Fh -> EEh -> 00h OTP_BYPS will be clear to 0b after the programming procedure

Note: The Trim Block can be writing for only "2" times. Trim command exceed the limit may cause the VCOMDC output unknown value.

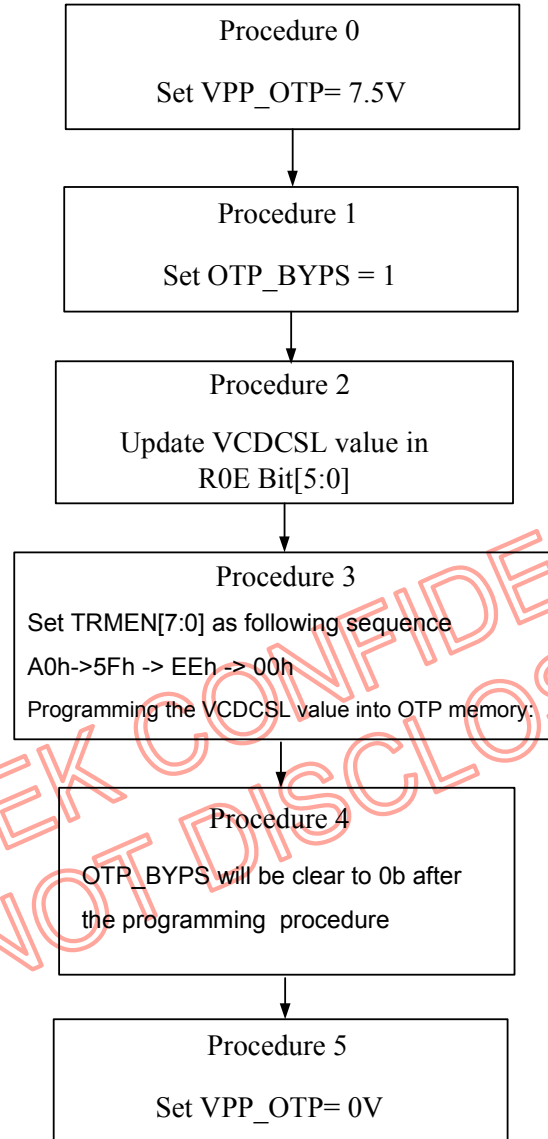
**R20: Wide and narrow display mode Control Register**

Bit	Name	Initial	R/W	Description
Bit [7:2]	-	-	-	Reserve
Bit [1:0]	WNSEL [1:0]	00b	R/W	Wide and narrow display mode select register

**WNSEL[1:0]: Wide and narrow display mode select register**

WNSEL1	WNSEL0	Display Mode
0	0	Normal display (Default)
0	1	Narrow display
1	0	Wide display
1	1	234-Line

Note: This function will be enabled under CCIR601 and CCIR656 mode

## Function Description

### Power On/Off Sequence

To prevent IC from power on reset fail, the rising time ( $T_{POR}$ ) of digital power supply VDD, should be control within the specification. Refer to the "AC Characteristic" for the detail timing, please.

#### Power-On Timing Sequence:

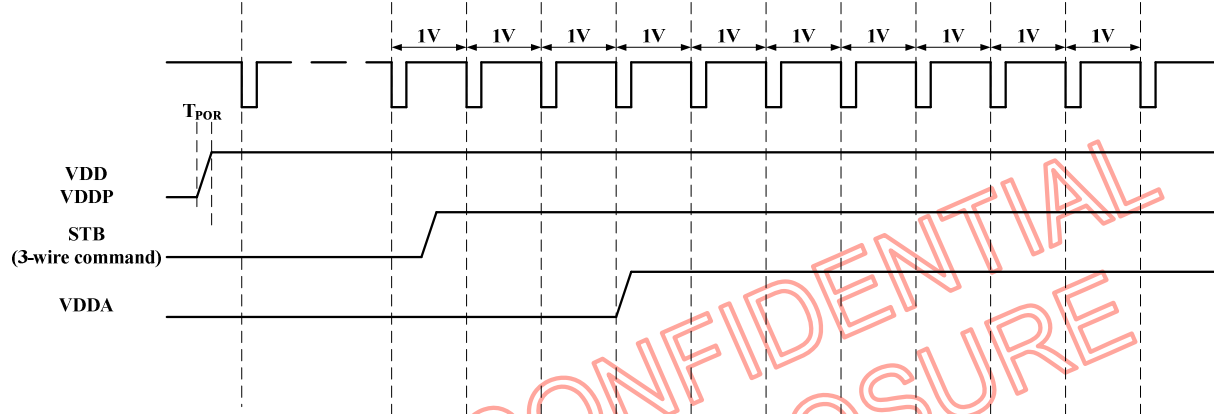

#### Power-off Timing Sequence:

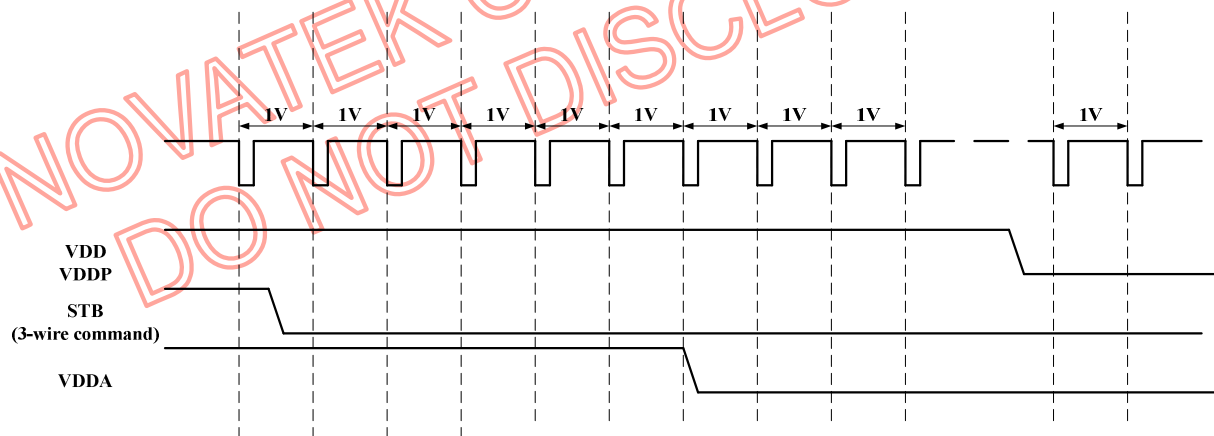

### External Reset (RSTB)

To prevent from abnormal reset condition, a glitch filter for RSTB is embedded in this chip. The external reset signal should keep active for large then reset time ( $T_{RSTB}$ ). Refer to the AC/DC Specification for the requirement.

### Input Data VS Output Voltage

Source Driver data output sequence can be control by "SHLR".

Output	SO1	SO2	SO3	---	SO958	SO959	SO960
SHLR="1"	First data			→			Last data
SHLR="0"	Last data			←			First data

Gate Driver scan output sequence can be control by "UPDN".

Scan	GO1	GO2	GO3	---	GO238	GO239	GO240
UPDN="1"	First scan			→			Last scan
UPDN="0"	Last scan			←			First scan

The figure below shows the relationship between the input data and the output voltage. Refer to the following pages to get the relative resistor value and voltage calculation method, please.

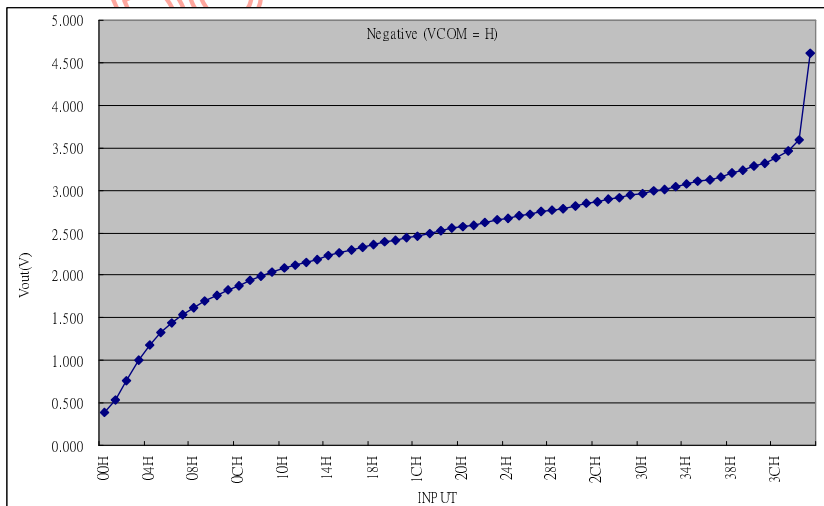
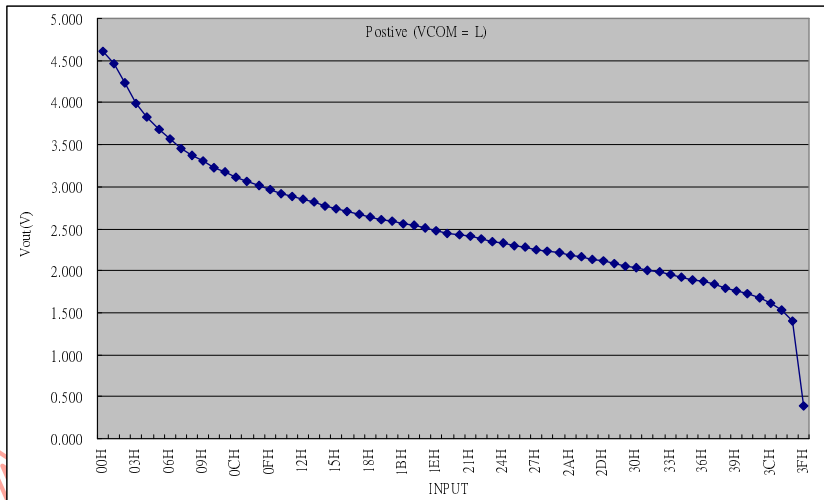



**Input Data and Output Voltage Reference Table (VSET = "0")**

@ VDDA = 5 V, VCOMOUT=L, POL=H	
Vno.	Unit = V
V1	4.610
V2	3.680
V3	3.115
V4	2.585
V5	2.185
V6	1.790
V7	0.390

@ VDDA = 5 V, VCOMOUT=H, POL=L	
Vno.	Unit = V
V1	0.390
V2	1.320
V3	1.885
V4	2.415
V5	2.815
V6	3.210
V7	4.610

Data	VCOMOUT=H, POL=L
(V1) 00H	VDDA X 0.078
01H	VDDA X 0.107
02H	VDDA X 0.153
03H	VDDA X 0.201
04H	VDDA X 0.236
(V2) 05H	VDDA X 0.264
06H	VDDA X 0.288
07H	VDDA X 0.308
08H	VDDA X 0.325
09H	VDDA X 0.340
0AH	VDDA X 0.354
0BH	VDDA X 0.366
(V3) 0CH	VDDA X 0.377
0DH	VDDA X 0.388
0EH	VDDA X 0.398
0FH	VDDA X 0.408
10H	VDDA X 0.416
11H	VDDA X 0.424
12H	VDDA X 0.431
13H	VDDA X 0.438
14H	VDDA X 0.446
15H	VDDA X 0.453
16H	VDDA X 0.459
17H	VDDA X 0.465
18H	VDDA X 0.472
19H	VDDA X 0.478
(V4) 1AH	VDDA X 0.483
1BH	VDDA X 0.488
1CH	VDDA X 0.493
1DH	VDDA X 0.499
1EH	VDDA X 0.505
1FH	VDDA X 0.510
20H	VDDA X 0.514
21H	VDDA X 0.519
22H	VDDA X 0.525
23H	VDDA X 0.530
24H	VDDA X 0.535
25H	VDDA X 0.540
26H	VDDA X 0.545
27H	VDDA X 0.550
28H	VDDA X 0.554
29H	VDDA X 0.558
(V5) 2AH	VDDA X 0.563
2BH	VDDA X 0.568
2CH	VDDA X 0.573
2DH	VDDA X 0.578
2EH	VDDA X 0.583
2FH	VDDA X 0.588
30H	VDDA X 0.593
31H	VDDA X 0.598
32H	VDDA X 0.603
33H	VDDA X 0.609
34H	VDDA X 0.615
35H	VDDA X 0.621
36H	VDDA X 0.626
37H	VDDA X 0.632
(V6) 38H	VDDA X 0.642
39H	VDDA X 0.648
3AH	VDDA X 0.656
3BH	VDDA X 0.665
3CH	VDDA X 0.677
3DH	VDDA X 0.693
3EH	VDDA X 0.719
(V7) 3FH	VDDA X 0.922

Data	VCOMOUT=L, POL=H
(V1) 00H	VDDA X 0.922
01H	VDDA X 0.893
02H	VDDA X 0.847
03H	VDDA X 0.799
04H	VDDA X 0.764
(V2) 05H	VDDA X 0.736
06H	VDDA X 0.712
07H	VDDA X 0.692
08H	VDDA X 0.675
09H	VDDA X 0.660
0AH	VDDA X 0.646
0BH	VDDA X 0.634
(V3) 0CH	VDDA X 0.623
0DH	VDDA X 0.612
0EH	VDDA X 0.602
0FH	VDDA X 0.592
10H	VDDA X 0.584
11H	VDDA X 0.576
12H	VDDA X 0.569
13H	VDDA X 0.562
14H	VDDA X 0.554
15H	VDDA X 0.547
16H	VDDA X 0.541
17H	VDDA X 0.535
18H	VDDA X 0.528
19H	VDDA X 0.522
(V4) 1AH	VDDA X 0.517
1BH	VDDA X 0.512
1CH	VDDA X 0.507
1DH	VDDA X 0.501
1EH	VDDA X 0.495
1FH	VDDA X 0.490
20H	VDDA X 0.486
21H	VDDA X 0.481
22H	VDDA X 0.475
23H	VDDA X 0.470
24H	VDDA X 0.465
25H	VDDA X 0.460
26H	VDDA X 0.455
27H	VDDA X 0.450
28H	VDDA X 0.446
29H	VDDA X 0.442
(V5) 2AH	VDDA X 0.437
2BH	VDDA X 0.432
2CH	VDDA X 0.427
2DH	VDDA X 0.422
2EH	VDDA X 0.417
2FH	VDDA X 0.412
30H	VDDA X 0.407
31H	VDDA X 0.402
32H	VDDA X 0.397
33H	VDDA X 0.391
34H	VDDA X 0.385
35H	VDDA X 0.379
36H	VDDA X 0.374
37H	VDDA X 0.368
(V6) 38H	VDDA X 0.358
39H	VDDA X 0.352
3AH	VDDA X 0.344
3BH	VDDA X 0.335
3CH	VDDA X 0.323
3DH	VDDA X 0.307
3EH	VDDA X 0.281
(V7) 3FH	VDDA X 0.078

Note: Gamma Table will be difference for each custom. Contact to Novatek for the detail information, please.

## Data Input Format

### 1. RGB input Data format

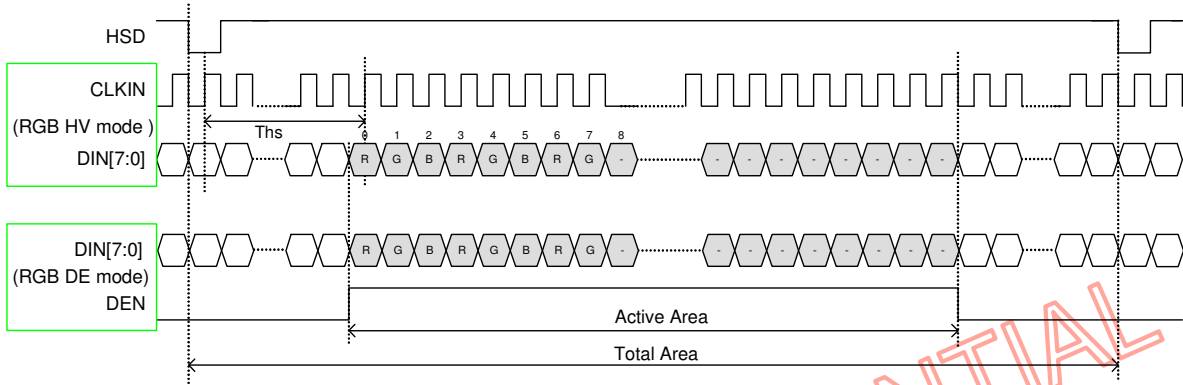

### 2. YUV input Data format

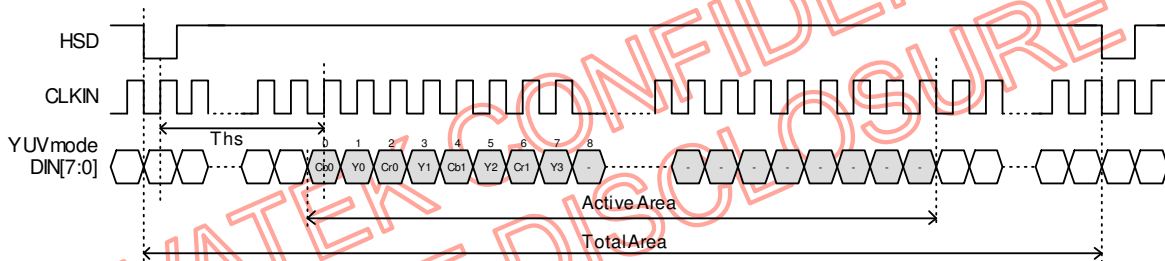

### 3. CCIR\_656 Mode Data format

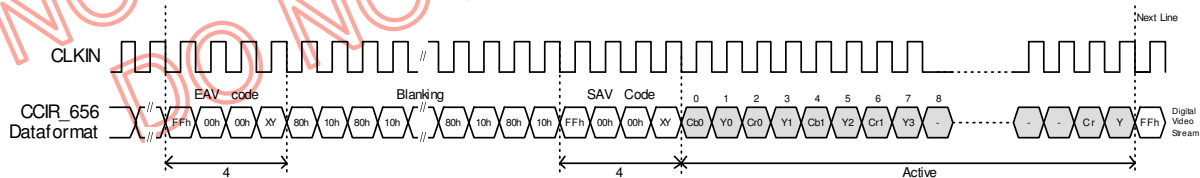

### 4. Data Active Area

Input Format	Format Standard	CLKIN (MHz)	HSD (CLKIN)	Total Area (CLKIN)	Active Area (CLKIN)	Note
YUV	CCIR 601	27	1	1716	1440	
	CCIR 656			1728		
	CCIR 601	24.54	1	1560	1280	
8bit RGB	8 bit RGB	27	1	1716	960	960x240
24bit RGB	24 bit RGB	6.4	1	408	320	

**5. YUV\_601/656 to RGB conversion**

AVGY=0:

$$R_n = 1.164(Y_{2n-16}) + 1.596(Cr_n - 128)$$

$$G_n = 1.164(Y_{2n-16}) - 0.813(Cr_n - 128) - 0.392(Cb_n - 128); [Y=16\sim 235, Cr \& Cb=16\sim 240]$$

$$B_n = 1.164(Y_{2n-16}) + 2.017(Cb_n - 128)$$

AVGY=1:

$$R_n = 1.164((Y_{2n} + Y_{2n+1})/2 - 16) + 1.596(Cr_n - 128)$$

$$G_n = 1.164((Y_{2n} + Y_{2n+1})/2 - 16) - 0.813(Cr_n - 128) - 0.392(Cb_n - 128); [Y=16\sim 235, Cr \& Cb=16\sim 240]$$

$$B_n = 1.164((Y_{2n} + Y_{2n+1})/2 - 16) + 2.017(Cb_n - 128)$$

**6. Brightness / Contrast Adjustment**

Contrast:

$$G_n = G[7:0] \times \text{Contrast} (0 \text{ to } 3.875)$$

$$R_n = R[7:0] \times \text{Contrast} (0 \text{ to } 3.875) \times \text{Sub-Contrast R} (0.8 \text{ to } 1.175)$$

$$B_n = B[7:0] \times \text{Contrast} (0 \text{ to } 3.875) \times \text{Sub-Contrast B} (0.8 \text{ to } 1.175)$$

Brightness:

$$G_n = G[7:0] + \text{Brightness} (-128 \text{ to } +126)$$

$$R_n = R[7:0] + \text{Brightness} (-128 \text{ to } +126) + \text{Sub-Brightness R} (-32 \text{ to } +31)$$

$$B_n = B[7:0] + \text{Brightness} (-128 \text{ to } +126) + \text{Sub-Brightness B} (-32 \text{ to } +31)$$

NOVATEK CONFIDENTIAL  
DO NOT DISCLOSE

## Absolute Maximum Ratings

Logic supply voltage, VDD	-0.5V to +5V
Analog supply voltage, VDDA	-0.5V to +7.5V
Supply voltage, VDDP	-0.5V to +5.5V
Supply voltage, V1~ V6	-0.3 ~VDDA+0.3
VGH~VGL	-0.3~ +25V
Storage temperature	-55°C to +125°C
Operating temperature	-20°C to +85°C

Stresses above those listed under “Absolute Maximum Ratings” may cause permanent damage to the device. These are stress ratings only. Functional operation of this device at these or under any other conditions above those indicated in the operational sections of this specification are not implied and exposure to absolute maximum rating conditions for extended periods may affect device reliability.

## DC Electrical Characteristics

(For the digital circuit: Test Condition: VDD=VDDP=3.3V , VDDA=5.0V, GND=GND A=GNDP= 0V, TA=25°C)

Parameter	Symbol	Min.	Typ.	Max.	Unit	Conditions
<b>Digital Block Circuit</b>						
Digital Supply Voltage	VDD	3.0	3.3	3.6	V	Digital power
Low Level Input Voltage	Vil	GND	-	0.2xVDD	V	Digital input pins TA=85°C
High Level Input Voltage	Vih	0.8xVDD	-	VDD	V	Digital input pins TA=85°C
Low Level Input Voltage	Vil	GND	-	0.2xVDD	V	Digital input pins TA=25°C
High Level Input Voltage	Vih	0.8xVDD	-	VDD	V	Digital input pins TA=25°C
Low Level Input Voltage	Vil	GND	-	0.1xVDD	V	Digital input pins TA= -20°C
High Level Input Voltage	Vih	0.9xVDD	-	VDD	V	Digital input pins TA= -20°C
Input Leakage Current	Ii	-	-	±1	µA	Digital input pins
Pull-high/low Impedance	Rin	-	200K	-	ohm	Digital control input pins
High Level Output Voltage	Voh	VDD-0.4	-	VDD	V	Digital output pins; loh = 400 uA
Low Level Output Voltage	Vol	GND	-	GND+0.4	V	Digital output pins; lol = -400 uA
Digital Stand-by Current	Iddst	-	(50)	(100)	µA	No load, CLKIN/VSD/HSD stopped
Digital Operating Current	Idd1	-	2	-	mA	CLKIN = 27 MHz (CCIR601 mode)
<b>Power Circuit</b>						
Charge Pump Supply Voltage	VDDP	3.0	3.3	3.6	V	For VGH/VGL power and Source Driver power, <b>must in this range</b>
VCOMAC output level	VCOMAC	4.6	-	6.1	V	By VCSL[2:0] setting VCOMAC = V <sub>(VCSL[2:0])</sub> +- 100mV
VCOMDC output level	VCOMDC	1.0	-	2.26	V	By VDCSL[5:0] setting VCOMDC = V <sub>(VDCSL[5:0])</sub> +- 50mV
Positive power supply	VGH	14.5	15	15.5	V	Gate driver load + procard load
Negative power supply	VGL	-9	-10	-11	V	Gate driver load + procard load
Base drive current	IDRV	-	-	10	mA	VDDP=3.3V, DRV=0.7 V
DRV output voltage	VDRV	GND +0.1	-	VDD -0.1	V	
Feed back voltage	VFB	0.55	0.6	0.65	V	DC/DC operating, VBL current=20 mA

Parameter	Symbol	Min.	Typ.	Max.	Unit	Conditions
<b>Analog Block Circuit</b>						
Analog Supply Voltage	VDDA	5.0	5.2	6.0	V	Analog circuit power from Power Block
Voltage Deviation of Outputs	Vvd	-	±20	±35	mV	Vo=0.1V ~ 0.5V & VDDA - 0.5 ~ VDDA - 0.1V
			±15	±25	mV	Vo=0.5V ~ VDDA-0.5V
Low-Level Output Current of VCOMOUT	IOLF	-	-10	-	mA	Force VCOMAC = 6.0V VCOMOUT output = 0V V.S. 0.9V
High-Level Output Current of VCOMOUT	IOHF	-	10	-	mA	Force VCOMAC = 6.0V VCOMOUT output = 6.0V V.S 5.1V
Source Low-Level Output Current	I <sub>oLS</sub>	-	-30	-	µA	Son = Vo V.S. (Vo+0.9)
Source High-Level Output Current	I <sub>oHS</sub>	-	30	-	µA	Son = Vo V.S. (Vo-0.9)
Gate Low-Level Output Current	IOLG	-	-250	-	µA	GOn; Vo=VGL V.S. (VGL +0.5)
Gate High-Level Output Current	IOHG	-	250	-	µA	GOn; Vo=VGH V.S. (VGH -0.5)
Analog Stand-by Current	Iddast	-	-	100	µA	STBYB = "0", all function are shutdown
Analog Operating Current	Idda	-	10	-	mA	No load, CLKIN = 27MHz, Fld=15KHz

NOVATEK CONFIDENTIAL  
DO NOT DISCLOSE

## AC Electrical Characteristics

Test Condition: (VDD=VDDP=3.3V, VDDA=5.0V, GND=GND A=GNDP=0V, TA= 25°C)

Parameter	Symbol	Min.	Typ.	Max.	Unit	Conditions
<b>System Operation Timing</b>						
VDD power source slew time	T <sub>POR</sub>			1000	us	From 0V to 90% VDD
RSTB active pulse width	T <sub>RSTB</sub>	40			us	VDD = 3.3V
<b>Input Output Timing</b>						
CLKIN clock time	T <sub>clk</sub>	-		35.7	ns	CLKIN = 28MHz
HSD to CLKIN	T <sub>hc</sub>	-	-	1	CLKIN	
HSD width	T <sub>wh</sub>	1	-	-	CLKIN	
VSD width	T <sub>vwh</sub>	1	-	-	Th	
HSD period time	T <sub>h</sub>	60	63.56	67	us	
VSD setup time	T <sub>vst</sub>	12	-	-	ns	
VSD hold time	T <sub>vhd</sub>	12	-	-	ns	
HSD setup time	T <sub>hst</sub>	12	-	-	ns	
HSD hold time	T <sub>hhd</sub>	12	-	-	ns	
Data set-up time	T <sub>dsu</sub>	12	-	-	ns	DIN[23:0] to CLKIN
Data hold time	T <sub>dhd</sub>	12	-	-	ns	DIN[23:0] to CLKIN
DEN setup time	T <sub>esd</sub>	12	-	-	ns	DEN to CLKIN
Time that VSD to 1 <sup>st</sup> line data input	T <sub>vs</sub>	2	13	127	Th	@CCIR601 / 8bit RGB HV mode Control by HDLY[6:0] setting T <sub>vs</sub> = HDLY[6:0]
Time that CCIR_V to 1 <sup>st</sup> line data input	T <sub>vs</sub>	12	20	28	Th	@CCIR656 NTSC mode Control by HDLY[6:0] setting T <sub>vs</sub> = HDLY[6:0]
Time that CCIR_V to 1 <sup>st</sup> line data input	T <sub>vs</sub>	17	25	33	Th	@CCIR656 PAL mode Control by HDLY[6:0] setting T <sub>vs</sub> = HDLY[6:0]
Time that VSD to 1 <sup>st</sup> line data input	T <sub>vs</sub>	2	13	127	Th	@24bit RGB HV mode Control by HDLY[6:0] setting T <sub>vs</sub> = HDLY[6:0]
Source output stable time 1	T <sub>st</sub>	-	25	30	us	96% final, CL=30pF, RL=2K
Gate output stable time	T <sub>gst</sub>	-	500	1000	ns	96% final, CL=40pF
VCOMOUT output stable time	T <sub>cst</sub>	-	4	8	us	96% final, CL=33nF, RL=100ohm
<b>3-wire serial communication AC timing</b>						
Serial clock	T <sub>spck</sub>	320	-	-	ns	
SPCK pulse duty	T <sub>scdut</sub>	40	50	60	%	
Serial data setup time	T <sub>isu</sub>	120	-	-	ns	
Serial data hold time	T <sub>ihd</sub>	120	-	-	ns	
Serial clock high/low	T <sub>ssw</sub>	120	-	-	ns	
Chip select distinguish	T <sub>cd</sub>	1	-	-	us	
SPENA to VSD	T <sub>cv</sub>	1	-	-	us	

## Timing Table

### CCIR601 Mode A/B \*

Parameter	Symbol	Min.	Typ.	Max.	Unit	Conditions
CLKIN frequency	Fclk	-	24.54 /27		MHz	VDD = 3.0 ~3.6V
CLKIN cycle time	Tclk	-	40/37		ns	
CLKIN pulse duty	Tcwh	40	50	60	%	Tclk
Time from HSD to VCOMOUT	Thvcm	-	66	-	CLKIN	
Time from HSD to DATSEQ	Thseq	-	60	-	CLKIN	
Time from HSD to Gate output n line	Thgz	-	30	-	CLKIN	
Time from HSD to Gate output n+1 line	Thgo	-	100	-	CLKIN	
Time from HSD to 1'st data input (PAL)	Ths	128	264	-	CLKIN	DDLY = 136, Offset = 128 (fixed)
Time from HSD to 1'st data input (NTSC)	Ths	128	244	-	CLKIN	DDLY = 116, Offset = 128 (fixed)

### CCIR656 Mode A/B \*

Parameter	Symbol	Min.	Typ.	Max.	Unit	Conditions
CLKIN frequency	Fclk	-	27		MHz	VDD = 3.0 ~3.6V
CLKIN cycle time	Tclk	-	37		ns	
CLKIN pulse duty	Tcwh	40	50	60	%	Tclk
Time from EAV to VCOMOUT	Thvcm	-	66	-	CLKIN	
Time from EAV to DATSEQ	Thseq	-	60	-	CLKIN	
Time from HSD to Gate output n line	Thgz	-	30	-	CLKIN	
Time from HSD to Gate output n+1 line	Thgo	-	100	-	CLKIN	
Time from EAV to 1'st data input (PAL)	Ths	128	288	-	CLKIN	DDLY = 152, Offset = 128 (fixed)
Time from EAV to 1'st data input (NTSC)	Ths	128	276	-	CLKIN	DDLY = 140, Offset = 128 (fixed)

### 8 Bit RGB 960 CH Mode

Parameter	Symbol	Min.	Typ.	Max.	Unit	Conditions
CLKIN frequency	Fclk	-	27		MHz	VDD = 3.0 ~3.6V
CLKIN cycle time	Tclk	-	37		ns	
CLKIN pulse duty	Tcwh	40	50	60	%	Tclk
Time from HSD to VCOMOUT	Thvcm	-	25	-	CLKIN	
Time from HSD to DATSEQ	Thseq	-	20	-	CLKIN	
Time from HSD to Gate output n line	Thgz	-	5	-	CLKIN	
Time from HSD to Gate output n+1 line	Thgo	-	45	-	CLKIN	
Time that HSD to 1'st data input(NTSC)	Ths	35	70	255	CLKIN	DDLY = 70, Offset = 0 (fixed)

### 24 Bit RGB Mode (@ SEL[3:0] = 1100 or 1101)

Parameter	Symbol	Min.	Typ.	Max.	Unit	Conditions
CLKIN frequency	Fclk	-	6.4		MHz	VDD = 3.0 ~3.6V
CLKIN cycle time	Tclk	-	156		ns	
CLKIN pulse duty	Tcwh	40	50	60	%	Tclk
Time from HSD to VCOMOUT	Thvcm	-	30	-	CLKIN	
Time from HSD to DATSEQ	Thseq	-	20	-	CLKIN	
Time from HSD to Gate output n line	Thgz	-	5	-	CLKIN	
Time from HSD to Gate output n+1 line	Thgo	-	45	-	CLKIN	
Time that HSD to 1'st data input(NTSC)	Ths	40	70	255	CLKIN	DDLY = 70, Offset = 0 (fixed)



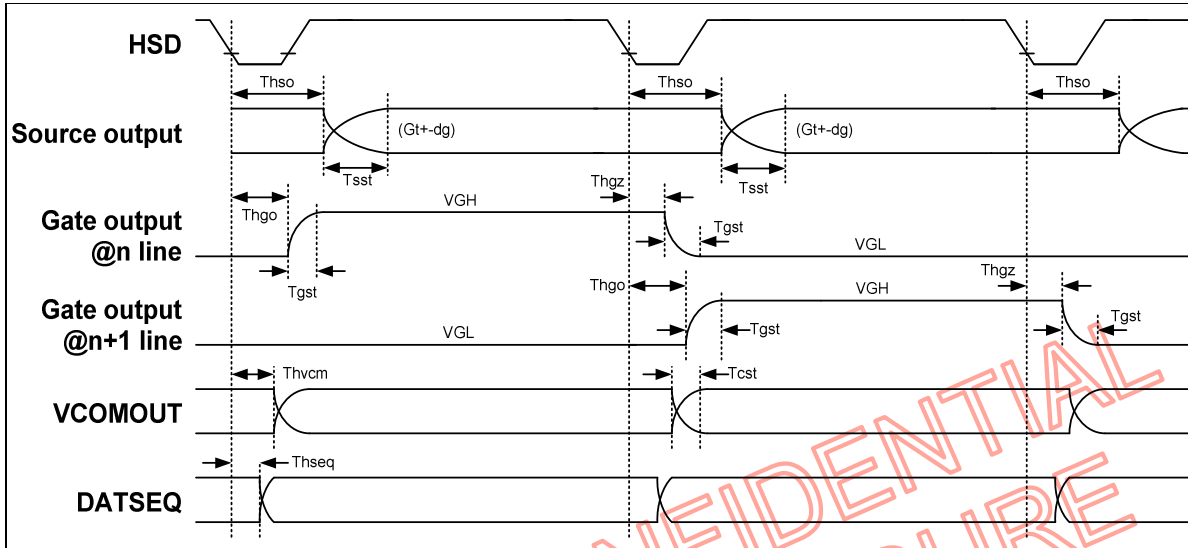
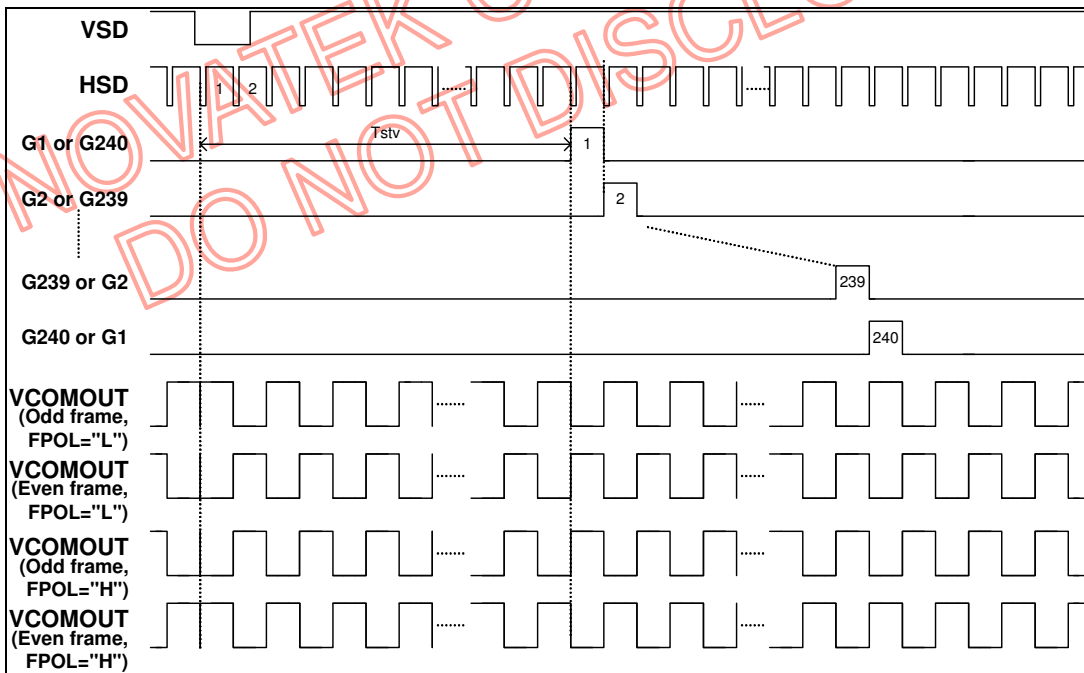

**Source Driver Output Timing Diagram**

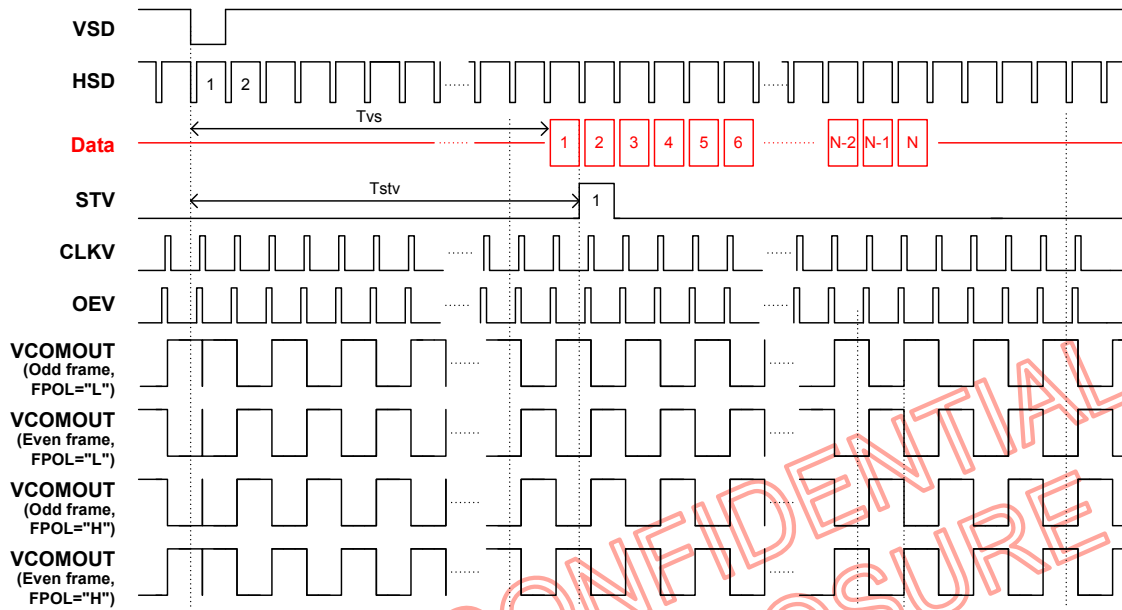
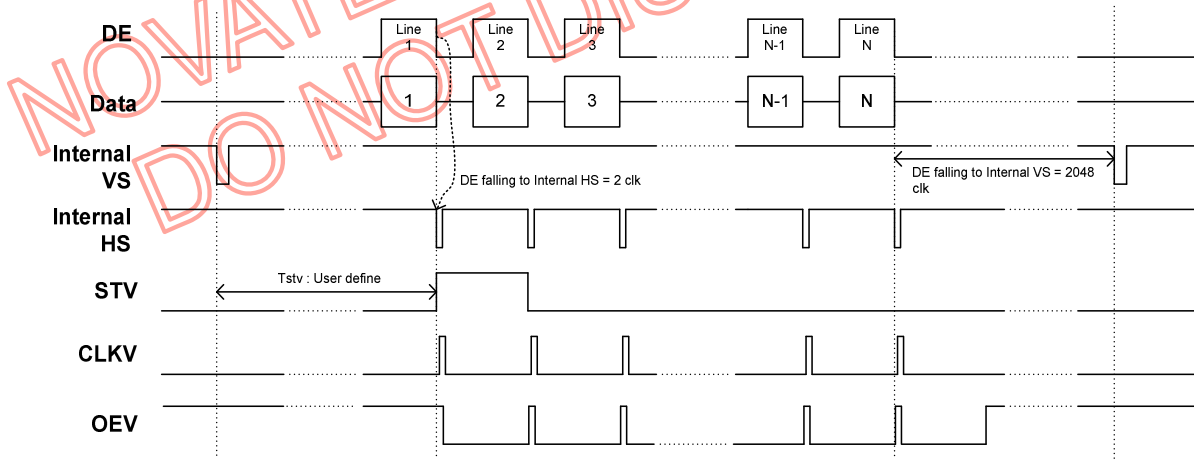
**Gate Driver Output Timing Diagram**

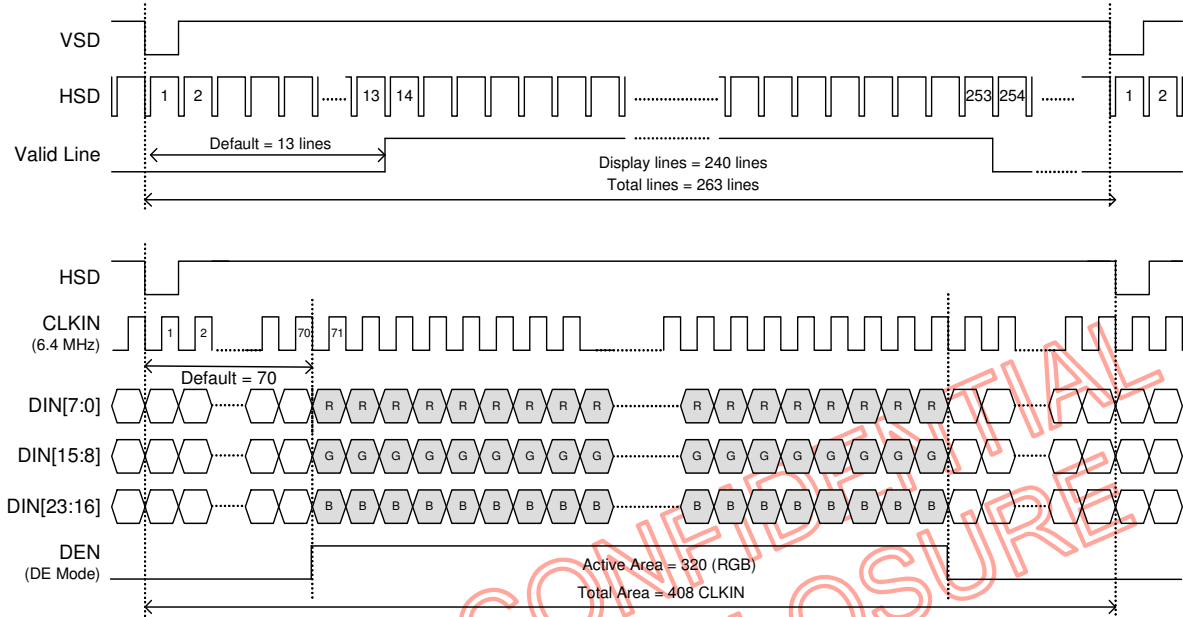
**Vertical Timing Diagram (HV Mode)**

**Vertical Timing Diagram (DE Mode)**

**Input Data Timing (24 bit RGB mode for 960 x 240 @ SEL[3:0] = 1100b)**

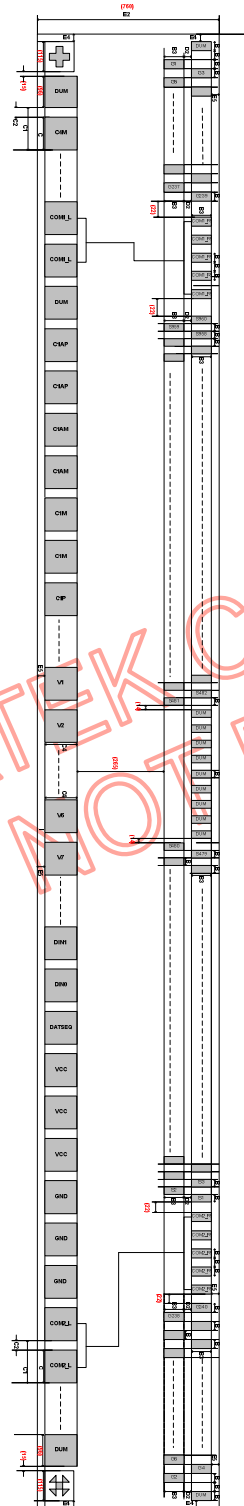
NOVATEK CONFIDENTIAL  
DO NOT DISCLOSE

### Pad Location



NOVATEK CONFIDENTIAL  
DO NOT DISCLOSURE

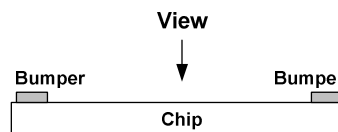

Mar 10,2008

36

Version 0.7

With respect to the information represented in this document, Novatek makes no warranty, expressed or implied, including the warranties of merchantability, fitness for a particular purpose, non-infringement, or assumes any legal liability or responsibility for the accuracy, completeness, or usefulness of any such information.

## Alignment Mark

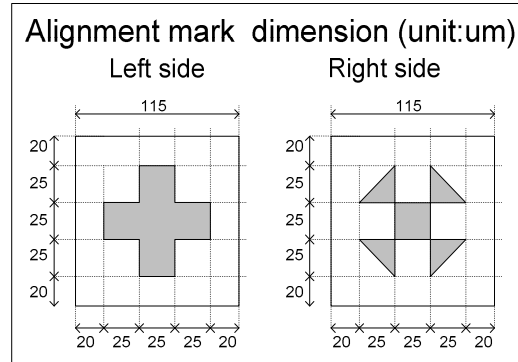

## Pad Information

Symbol	Dimension (um)
B	17
B3	110
C	100
C1	127
C2	27
C4	115
D2	30
E1	21310
E2	760
E4	65
E5	65

**\*Remark: Chip dimension include scribe line**

## Application Notes

### PWM for LED Backlight Control

NT39016 using continuous analog type PWM control architecture for better performance. An auto protect detection feature was also integrated. The PWM circuit will enter power down state when the internal CKV signal is below 1KHz.

#### Only one LED

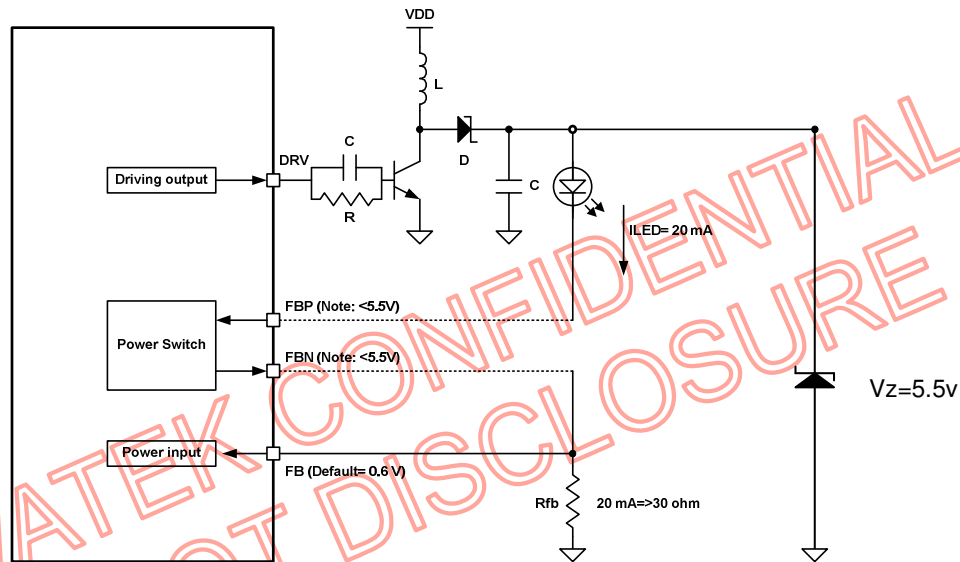

#### More than one LED

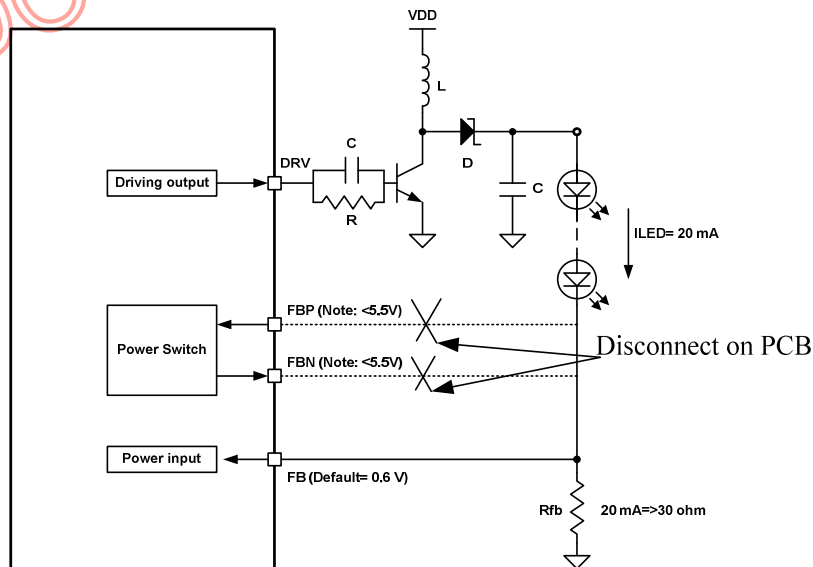

S

**Appendix A: Pad Coordinate**

Pad No.	Name	X	Y	Pad No.	Name	X	Y	Pad No.	Name	X	Y	Pad No.	Name	X	Y	Pad No.	Name	X	Y
1	Alignment	-1032.5	-257.5	89	TP7	855	-257.5	177	GO18	10411.5	120	265	GO194	8915.5	120	353	SO069	7207.5	120
2	DUM	-1042	-257.5	90	TP6	762	-257.5	178	GO20	10394.5	120	266	GO196	8895.5	120	354	SO061	7230.5	120
3	CM	-1027	-257.5	91	TP5	889	-257.5	179	GO22	10377.5	120	267	GO198	8881.5	120	355	SO062	7273.5	120
4	CM	-10160	-257.5	92	TP4	1016	-257.5	180	GO24	10360.5	120	268	GO200	8867.5	120	356	SO063	7256.5	120
5	CM	-10033	-257.5	93	TP3	1143	-257.5	181	GO26	10343.5	120	269	GO202	8847.5	120	357	SO064	7239.5	120
6	CM	-9906	-257.5	94	TP2	1270	-257.5	182	GO28	10326.5	120	270	GO204	8833.5	120	358	SO065	7222.5	120
7	VGH	-9779	-257.5	95	DUM	1397	-257.5	183	GO30	10309.5	120	271	GO206	8813.5	120	359	SO066	7205.5	120
8	VGH	-9652	-257.5	96	TP2	1524	-257.5	184	GO32	10292.5	120	272	GO208	8793.5	120	360	SO067	7188.5	120
9	VGH	-9525	-257.5	97	TP1	1651	-257.5	185	GO34	10275.5	120	273	GO210	8779.5	120	361	SO068	7171.5	120
10	CM	-9398	-257.5	98	DUM	1778	-257.5	186	GO36	10258.5	120	274	GO212	8762.5	120	362	SO069	7154.5	120
11	CM	-9271	-257.5	99	TP0	1905	-257.5	187	GO38	10241.5	120	275	GO214	8745.5	120	363	SO070	7137.5	120
12	C3P	-9144	-257.5	100	VDDA	2032	-257.5	188	GO40	10224.5	120	276	GO216	8728.5	120	364	SO071	7120.5	120
13	C3P	-9017	-257.5	101	VDDA	2159	-257.5	189	GO42	10207.5	120	277	GO218	8711.5	120	365	SO072	7103.5	120
14	C3P	-8890	-257.5	102	VDDA	2286	-257.5	190	GO44	10190.5	120	278	GO220	8694.5	120	366	SO073	7086.5	120
15	C3P	-8763	-257.5	103	GND	2413	-257.5	191	GO46	10173.5	120	279	GO222	8677.5	120	367	SO074	7069.5	120
16	CM	-8636	-257.5	104	GND	2540	-257.5	192	GO48	10156.5	120	280	GO224	8660.5	120	368	SO075	7052.5	120
17	CM	-8509	-257.5	105	GND	2667	-257.5	193	GO50	10139.5	120	281	GO226	8643.5	120	369	SO076	7035.5	120
18	COM1_L	-8382	-257.5	106	GND	2794	-257.5	194	GO52	10122.5	120	282	GO228	8626.5	120	370	SO077	7018.5	120
19	COM1_L	-8255	-257.5	107	GND	2921	-257.5	195	GO54	10105.5	120	283	GO230	8609.5	120	371	SO078	7001.5	120
20	DUM	-8128	-257.5	108	GND	3048	-257.5	196	GO56	10088.5	120	284	GO232	8592.5	120	372	SO079	6984.5	120
21	CIAP	-8001	-257.5	109	VDD	3175	-257.5	197	GO58	10071.5	120	285	GO234	8575.5	120	373	SO080	6967.5	120
22	CIAP	-7874	-257.5	110	VDD	3302	-257.5	198	GO60	10054.5	120	286	GO236	8558.5	120	374	SO081	6950.5	120
23	CIAM	-7747	-257.5	111	VDD	3429	-257.5	199	GO62	10037.5	120	287	GO238	8541.5	120	375	SO082	6933.5	120
24	CIAM	-7620	-257.5	112	RSTB	3556	-257.5	200	GO64	10020.5	120	288	GO240	8524.5	120	376	SO083	6916.5	120
25	CM	-7493	-257.5	113	DUM	3683	-257.5	201	GO66	10003.5	120	289	COM2_R	8485.5	260	377	SO084	6899.5	120
26	CM	-7366	-257.5	114	SPDA	3810	-257.5	202	GO68	9986.5	120	290	COM2_R	8451.5	260	378	SO085	6882.5	120
27	CIP	-7239	-257.5	115	SPSW	3937	-257.5	203	GO70	9969.5	120	291	COM2_R	8417.5	260	379	SO086	6865.5	120
28	CIP	-7112	-257.5	116	PINCLB	4064	-257.5	204	GO72	9952.5	120	292	COM2_R	8383.5	260	380	SO087	6848.5	120
29	GNDP	-6985	-257.5	117	SPCK	4191	-257.5	205	GO74	9935.5	120	293	COM2_R	8349.5	260	381	SO088	6831.5	120
30	GNDP	-6858	-257.5	118	SPENB	4318	-257.5	206	GO76	9918.5	120	294	SO001	8315.5	120	382	SO089	6814.5	120
31	GNDP	-6731	-257.5	119	DEN	4445	-257.5	207	GO78	9901.5	120	295	SO002	8281.5	120	383	SO090	6797.5	120
32	VDDP	-6604	-257.5	120	HSD	4572	-257.5	208	GO80	9884.5	120	296	SO003	8247.5	120	384	SO091	6780.5	120
33	VDDP	-6477	-257.5	121	VSD	4699	-257.5	209	GO82	9867.5	120	297	SO004	8213.5	120	385	SO092	6763.5	120
34	VDDP	-6350	-257.5	122	CLKIN	4826	-257.5	210	GO84	9850.5	120	298	SO005	8179.5	120	386	SO093	6746.5	120
35	DUM	-6223	-257.5	123	DIN23	4953	-257.5	211	GO86	9833.5	120	299	SO006	8145.5	120	387	SO094	6729.5	120
36	VGL	-6096	-257.5	124	DIN22	5080	-257.5	212	GO88	9816.5	120	300	SO007	8111.5	120	388	SO095	6712.5	120
37	VGL	-5969	-257.5	125	DIN21	5207	-257.5	213	GO90	9799.5	120	301	SO008	8077.5	120	389	SO096	6695.5	120
38	VGL	-5842	-257.5	126	DIN20	5334	-257.5	214	GO92	9782.5	120	302	SO009	8043.5	120	390	SO097	6678.5	120
39	DUM	-5715	-257.5	127	DIN19	5461	-257.5	215	GO94	9765.5	120	303	SO010	8009.5	120	391	SO098	6661.5	120
40	Via2	-5588	-257.5	128	DIN18	5588	-257.5	216	GO96	9748.5	120	304	SO011	7975.5	120	392	SO099	6644.5	120
41	Via2	-5461	-257.5	129	DIN17	5715	-257.5	217	GO98	9731.5	120	305	SO012	7941.5	120	393	SO100	6627.5	120
42	Via2	-5334	-257.5	130	DIN16	5842	-257.5	218	GO100	9714.5	120	306	SO013	7907.5	120	394	SO101	6610.5	120
43	DUM	-5207	-257.5	131	DIN15	5969	-257.5	219	GO102	9697.5	120	307	SO014	7873.5	120	395	SO102	6593.5	120
44	GND	-5080	-257.5	132	DIN14	6096	-257.5	220	GO104	9680.5	120	308	SO015	7839.5	120	396	SO103	6576.5	120
45	GND	-4953	-257.5	133	DIN13	6223	-257.5	221	GO106	9663.5	120	309	SO016	7805.5	120	397	SO104	6559.5	120
46	GND	-4826	-257.5	134	DIN12	6350	-257.5	222	GO108	9646.5	120	310	SO017	7771.5	120	398	SO105	6542.5	120
47	DUM	-4699	-257.5	135	DIN11	6477	-257.5	223	GO110	9629.5	120	311	SO018	7737.5	120	399	SO106	6525.5	120
48	VCOMOUT	-4572	-257.5	136	DIN10	6604	-257.5	224	GO112	9612.5	120	312	SO019	7703.5	120	400	SO107	6508.5	120
49	VCOMOUT	-4445	-257.5	137	DIN9	6731	-257.5	225	GO114	9595.5	120	313	SO020	7669.5	120	401	SO108	6491.5	120
50	VCOMOUT	-4318	-257.5	138	DIN8	6858	-257.5	226	GO116	9578.5	120	314	SO021	7635.5	120	402	SO109	6474.5	120
51	Via1	-4191	-257.5	139	DIN7	6985	-257.5	227	GO118	9561.5	120	315	SO022	7601.5	120	403	SO110	6457.5	120
52	Via1	-4064	-257.5	140	DIN6	7112	-257.5	228	GO120	9544.5	120	316	SO023	7567.5	120	404	SO111	6440.5	120
53	Via1	-3937	-257.5	141	DIN5	7239	-257.5	229	GO122	9527.5	120	317	SO024	7533.5	120	405	SO112	6423.5	120
54	DUM	-3810	-257.5	142	DIN4	7366	-257.5	230	GO124	9510.5	120	318	SO025	7499.5	120	406	SO113	6406.5	120
55	VCOMAC	-3683	-257.5	143	DIN3	7493	-257.5	231	GO126	9493.5	120	319	SO026	7465.5	120	407	SO114	6389.5	120
56	VCOMAC	-3556	-257.5	144	DIN2	7620	-257.5	232	GO128	9476.5	120	320	SO027	7431.5	120	408	SO115	6372.5	120
57	VCOMAC	-3429	-257.5	145	DIN1	7747	-257.5	233	GO130	9459.5	120	321	SO028	7397.5	120	409	SO116	6355.5	120
58	DUM	-3302	-257.5	146	DIN0	7874	-257.5	234	GO132	9442.5	120	322	SO029	7363.5	120	410	SO117	6338.5	120
59	VCOM	-3175	-257.5	147	DATSEQ	8001	-257.5	235	GO134	9425.5	120	323	SO030	7329.5	120	411	SO118	6321.5	120
60	VCOM	-3048	-257.5	148	VCC	8128	-257.5	236	GO136	9408.5	120	324	SO031	7295.5	120	412	SO119	6304.5	120
61	VCOM	-2921	-257.5	149	VCC	8255	-257.5	237	GO138	9391.5	120	325	SO032	7261.5	120	413	SO120	6287.5	120
62	POL	-2794	-257.5	150	VCC	8382	-257.5	238	GO140	9374.5	120	326	SO033	7227.5	120	414	SO121	6270.5	120
63	DUM	-2667	-257.5	151	GND	8509	-257.5	239	GO142	9357.5	120	327	SO034	7193.5	120	415	SO122	6253.5	120
64	VPSW	-2540	-257.5	152	GND	8636	-257.5	240	GO144	9340.5	120	328	SO035	7159.5	120	416	SO123	6236.5	120
65	DUM	-2413	-257.5	153	GND	8763	-257.5	241	GO146	9323.5	120	329	SO036	7125.5	120	417	SO124	6219.5	120
66	TP18	-2286	-257.5	154	COM2_L	8890	-257.5	242	GO148	9306.5	120	330	SO037	7091.5	120	418	SO125	6202.5	120
67	TP17	-2159	-257.5	155	COM2_L	9017	-257.5	243	GO150	9289.5	120	331	SO038	7057.5	120	419	SO126	6185.5	120
68	TP16	-2032	-257.5																

Pad No.	Name	X	Y	Pad No.	Name	X	Y	Pad No.	Name	X	Y	Pad No.	Name	X	Y	Pad No.	Name	X	Y
441	SO148	5811.5	120	529	SO236	4315.5	120	617	SO324	2819.5	120	705	SO412	1323.5	120	793	SO491	-337.5	120
442	SO149	5794.5	260	530	SO237	4298.5	260	618	SO325	2802.5	260	706	SO413	1306.5	260	794	SO492	-354.5	260
443	SO150	5777.5	120	531	SO238	4281.5	120	619	SO326	2785.5	120	707	SO414	1289.5	120	795	SO493	-371.5	120
444	SO151	5760.5	260	532	SO239	4264.5	260	620	SO327	2768.5	260	708	SO415	1272.5	260	796	SO494	-388.5	260
445	SO152	5743.5	120	533	SO240	4247.5	120	621	SO328	2751.5	120	709	SO416	1255.5	120	797	SO495	-405.5	120
446	SO153	5726.5	260	534	SO241	4230.5	260	622	SO329	2734.5	260	710	SO417	1238.5	260	798	SO496	-422.5	260
447	SO154	5709.5	120	535	SO242	4213.5	120	623	SO330	2717.5	120	711	SO418	1221.5	120	799	SO497	-439.5	120
448	SO155	5692.5	260	536	SO243	4196.5	260	624	SO331	2700.5	260	712	SO419	1204.5	260	800	SO498	-456.5	260
449	SO156	5675.5	120	537	SO244	4179.5	120	625	SO332	2683.5	120	713	SO420	1187.5	120	801	SO499	-473.5	120
450	SO157	5658.5	260	538	SO245	4162.5	260	626	SO333	2666.5	260	714	SO421	1170.5	260	802	SO500	-490.5	260
451	SO158	5641.5	120	539	SO246	4145.5	120	627	SO334	2649.5	120	715	SO422	1153.5	120	803	SO501	-507.5	120
452	SO159	5624.5	260	540	SO247	4128.5	260	628	SO335	2632.5	260	716	SO423	1136.5	260	804	SO502	-524.5	260
453	SO160	5607.5	120	541	SO248	4111.5	120	629	SO336	2615.5	120	717	SO424	1119.5	120	805	SO503	-541.5	120
454	SO161	5590.5	260	542	SO249	4094.5	260	630	SO337	2598.5	260	718	SO425	1102.5	260	806	SO504	-558.5	260
455	SO162	5573.5	120	543	SO250	4077.5	120	631	SO338	2581.5	120	719	SO426	1085.5	120	807	SO505	-575.5	120
456	SO163	5556.5	260	544	SO251	4060.5	260	632	SO339	2564.5	260	720	SO427	1068.5	260	808	SO506	-592.5	260
457	SO164	5539.5	120	545	SO252	4043.5	120	633	SO340	2547.5	120	721	SO428	1051.5	120	809	SO507	-609.5	120
458	SO165	5522.5	260	546	SO253	4026.5	260	634	SO341	2530.5	260	722	SO429	1034.5	260	810	SO508	-626.5	260
459	SO166	5505.5	120	547	SO254	4009.5	120	635	SO342	2513.5	120	723	SO430	1017.5	120	811	SO509	-643.5	120
460	SO167	5488.5	260	548	SO255	3992.5	260	636	SO343	2496.5	260	724	SO431	1000.5	260	812	SO510	-660.5	260
461	SO168	5471.5	120	549	SO256	3975.5	120	637	SO344	2479.5	120	725	SO432	983.5	120	813	SO511	-677.5	120
462	SO169	5454.5	260	550	SO257	3958.5	260	638	SO345	2462.5	260	726	SO433	966.5	260	814	SO512	-694.5	260
463	SO170	5437.5	120	551	SO258	3941.5	120	639	SO346	2445.5	120	727	SO434	949.5	120	815	SO513	-711.5	120
464	SO171	5420.5	260	552	SO259	3924.5	260	640	SO347	2428.5	260	728	SO435	932.5	260	816	SO514	-728.5	260
465	SO172	5403.5	120	553	SO260	3907.5	120	641	SO348	2411.5	120	729	SO436	915.5	120	817	SO515	-745.5	120
466	SO173	5386.5	260	554	SO261	3890.5	260	642	SO349	2394.5	260	730	SO437	898.5	260	818	SO516	-762.5	260
467	SO174	5369.5	120	555	SO262	3873.5	120	643	SO350	2377.5	120	731	SO438	881.5	120	819	SO517	-779.5	120
468	SO175	5352.5	260	556	SO263	3856.5	260	644	SO351	2360.5	260	732	SO439	864.5	260	820	SO518	-796.5	260
469	SO176	5335.5	120	557	SO264	3839.5	120	645	SO352	2343.5	120	733	SO440	847.5	120	821	SO519	-813.5	120
470	SO177	5318.5	260	558	SO265	3822.5	260	646	SO353	2326.5	260	734	SO441	830.5	260	822	SO520	-830.5	260
471	SO178	5301.5	120	559	SO266	3805.5	120	647	SO354	2309.5	120	735	SO442	813.5	120	823	SO521	-847.5	120
472	SO179	5284.5	260	560	SO267	3788.5	260	648	SO355	2292.5	260	736	SO443	796.5	260	824	SO522	-864.5	260
473	SO180	5267.5	120	561	SO268	3771.5	120	649	SO356	2275.5	120	737	SO444	779.5	120	825	SO523	-881.5	120
474	SO181	5250.5	260	562	SO269	3754.5	260	650	SO357	2258.5	260	738	SO445	762.5	260	826	SO524	-898.5	260
475	SO182	5233.5	120	563	SO270	3737.5	120	651	SO358	2241.5	120	739	SO446	745.5	120	827	SO525	-915.5	120
476	SO183	5216.5	260	564	SO271	3720.5	260	652	SO359	2224.5	260	740	SO447	728.5	260	828	SO526	-932.5	260
477	SO184	5199.5	120	565	SO272	3703.5	120	653	SO360	2207.5	120	741	SO448	711.5	120	829	SO527	-949.5	120
478	SO185	5182.5	260	566	SO273	3686.5	260	654	SO361	2190.5	260	742	SO449	694.5	260	830	SO528	-966.5	260
479	SO186	5165.5	120	567	SO274	3669.5	120	655	SO362	2173.5	120	743	SO450	677.5	120	831	SO529	-983.5	120
480	SO187	5148.5	260	568	SO275	3652.5	260	656	SO363	2156.5	260	744	SO451	660.5	260	832	SO530	-1000.5	260
481	SO188	5131.5	120	569	SO276	3635.5	120	657	SO364	2139.5	120	745	SO452	643.5	120	833	SO531	-1017.5	120
482	SO189	5114.5	260	570	SO277	3618.5	260	658	SO365	2122.5	260	746	SO453	626.5	260	834	SO532	-1034.5	260
483	SO190	5097.5	120	571	SO278	3601.5	120	659	SO366	2105.5	120	747	SO454	609.5	120	835	SO533	-1051.5	120
484	SO191	5080.5	260	572	SO279	3584.5	260	660	SO367	2088.5	260	748	SO455	592.5	260	836	SO534	-1068.5	260
485	SO192	5063.5	120	573	SO280	3567.5	120	661	SO368	2071.5	120	749	SO456	575.5	120	837	SO535	-1085.5	120
486	SO193	5046.5	260	574	SO281	3550.5	260	662	SO369	2054.5	260	750	SO457	558.5	260	838	SO536	-1102.5	260
487	SO194	5029.5	120	575	SO282	3533.5	120	663	SO370	2037.5	120	751	SO458	541.5	120	839	SO537	-1119.5	120
488	SO195	5012.5	260	576	SO283	3516.5	260	664	SO371	2020.5	260	752	SO459	524.5	260	840	SO538	-1136.5	260
489	SO196	4995.5	120	577	SO284	3499.5	120	665	SO372	2003.5	120	753	SO460	507.5	120	841	SO539	-1153.5	120
490	SO197	4978.5	260	578	SO285	3482.5	260	666	SO373	1986.5	260	754	SO461	490.5	260	842	SO540	-1170.5	260
491	SO198	4961.5	120	579	SO286	3465.5	120	667	SO374	1969.5	120	755	SO462	473.5	120	843	SO541	-1187.5	120
492	SO199	4944.5	260	580	SO287	3448.5	260	668	SO375	1952.5	260	756	SO463	456.5	260	844	SO542	-1204.5	260
493	SO200	4927.5	120	581	SO288	3431.5	120	669	SO376	1935.5	120	757	SO464	439.5	120	845	SO543	-1221.5	120
494	SO201	4910.5	260	582	SO289	3414.5	260	670	SO377	1918.5	260	758	SO465	422.5	260	846	SO544	-1238.5	260
495	SO202	4893.5	120	583	SO290	3397.5	120	671	SO378	1901.5	120	759	SO466	405.5	120	847	SO545	-1255.5	120
496	SO203	4876.5	260	584	SO291	3380.5	260	672	SO379	1884.5	260	760	SO467	388.5	260	848	SO546	-1272.5	260
497	SO204	4859.5	120	585	SO292	3363.5	120	673	SO380	1867.5	120	761	SO468	371.5	120	849	SO547	-1289.5	120
498	SO205	4842.5	260	586	SO293	3346.5	260	674	SO381	1850.5	260	762	SO469	354.5	260	850	SO548	-1306.5	260
499	SO206	4825.5	120	587	SO294	3329.5	120	675	SO382	1833.5	120	763	SO470	337.5	120	851	SO549	-1323.5	120
500	SO207	4808.5	260	588	SO295	3312.5	260	676	SO383	1816.5	260	764	SO471	320.5	260	852	SO550	-1340.5	260
501	SO208	4791.5	120	589	SO296	3295.5	120	677	SO384	1799.5	120	765	SO472	303.5	120	853	SO551	-1357.5	120
502	SO209	4774.5	260	590	SO297	3278.5	260	678	SO385	1782.5	260	766	SO473	286.5	260	854	SO552	-1374.5	260
503	SO210	4757.5	120	591	SO298	3261.5	120	679	SO386	1765.5	120	767	SO474	269.5	120	855	SO553	-1391.5	120
504	SO211	4740.5	260	592	SO299	3244.5	260	680	SO387	1748.5	260	768	SO475	252.5	260	856	SO554	-1408.5	260
505	SO212	4723.5	120	593	SO300	3227.5	120	681	SO388	1731.5	120	769	SO476	235.5	120	857	SO555	-1425.5	120
506	SO213	4706.5	260	594	SO301	3210.5	260	682	SO389	1714.5	260	770	SO477	218.5					



Pad No.	Name	X	Y	Pad No.	Name	X	Y	Pad No.	Name	X	Y	Pad No.	Name	X	Y	Pad No.	Name	X	Y
981	SO579	-1833.5	120	989	SO667	3220.5	120	1087	SO755	-4820.5	120	1146	SO843	-6321.5	120	1233	SO931	-7817.5	120
982	SO580	-1850.5	260	990	SO668	3346.5	260	1088	SO756	-4842.5	260	1146	SO844	-6338.5	260	1234	SO932	-7834.5	260
983	SO581	-1867.5	120	991	SO669	3363.5	120	1089	SO757	-4869.5	120	1147	SO845	-6355.5	120	1235	SO933	-7851.5	120
984	SO582	-1884.5	260	992	SO670	3380.5	260	1090	SO758	-4896.5	260	1148	SO846	-6372.5	260	1236	SO934	-7868.5	260
985	SO583	-1901.5	120	993	SO671	3397.5	120	1091	SO759	-4923.5	120	1149	SO847	-6389.5	120	1237	SO935	-7885.5	120
986	SO584	-1918.5	260	994	SO672	3414.5	260	1092	SO760	-4950.5	260	1150	SO848	-6406.5	260	1238	SO936	-7902.5	260
987	SO585	-1935.5	120	995	SO673	3431.5	120	1093	SO761	-4977.5	120	1151	SO849	-6423.5	120	1239	SO937	-7919.5	120
988	SO586	-1952.5	260	996	SO674	3448.5	260	1094	SO762	-4944.5	260	1152	SO850	-6440.5	260	1240	SO938	-7936.5	260
989	SO587	-1969.5	120	997	SO675	3465.5	120	1095	SO763	-4961.5	120	1153	SO851	-6457.5	120	1241	SO939	-7953.5	120
990	SO588	-1986.5	260	998	SO676	3482.5	260	1096	SO764	-4978.5	260	1154	SO852	-6474.5	260	1242	SO940	-7970.5	260
991	SO589	-2003.5	120	999	SO677	3499.5	120	1097	SO765	-4995.5	120	1155	SO853	-6491.5	120	1243	SO941	-7987.5	120
992	SO590	-2020.5	260	1000	SO678	3516.5	260	1098	SO766	-5012.5	260	1156	SO854	-6508.5	260	1244	SO942	-8004.5	260
993	SO591	-2037.5	120	1001	SO679	3533.5	120	1099	SO767	-5029.5	120	1157	SO855	-6525.5	120	1245	SO943	-8021.5	120
994	SO592	-2054.5	260	1002	SO680	3550.5	260	1100	SO768	-5046.5	260	1158	SO856	-6542.5	260	1246	SO944	-8038.5	260
995	SO593	-2071.5	120	1003	SO681	3567.5	120	1101	SO769	-5063.5	120	1159	SO857	-6559.5	120	1247	SO945	-8055.5	120
996	SO594	-2088.5	260	1004	SO682	3584.5	260	1102	SO770	-5080.5	260	1160	SO858	-6576.5	260	1248	SO946	-8072.5	260
997	SO595	-2105.5	120	1005	SO683	3601.5	120	1103	SO771	-5097.5	120	1161	SO859	-6593.5	120	1249	SO947	-8089.5	120
998	SO596	-2122.5	260	1006	SO684	3618.5	260	1104	SO772	-5114.5	260	1162	SO860	-6610.5	260	1250	SO948	-8106.5	260
999	SO597	-2139.5	120	1007	SO685	3635.5	120	1105	SO773	-5131.5	120	1163	SO861	-6627.5	120	1251	SO949	-8123.5	120
1000	SO598	-2156.5	260	1008	SO686	3652.5	260	1106	SO774	-5148.5	260	1164	SO862	-6644.5	260	1252	SO950	-8140.5	260
1001	SO599	-2173.5	120	1009	SO687	3669.5	120	1107	SO775	-5165.5	120	1165	SO863	-6661.5	120	1253	SO951	-8157.5	120
1002	SO600	-2190.5	260	1010	SO688	3686.5	260	1108	SO776	-5182.5	260	1166	SO864	-6678.5	260	1254	SO952	-8174.5	260
1003	SO601	-2207.5	120	1011	SO689	3703.5	120	1109	SO777	-5199.5	120	1167	SO865	-6695.5	120	1255	SO953	-8191.5	120
1004	SO602	-2224.5	260	1012	SO690	3720.5	260	1110	SO778	-5216.5	260	1168	SO866	-6712.5	260	1256	SO954	-8208.5	260
1005	SO603	-2241.5	120	1013	SO691	3737.5	120	1111	SO779	-5233.5	120	1169	SO867	-6729.5	120	1257	SO955	-8225.5	120
1006	SO604	-2258.5	260	1014	SO692	3754.5	260	1112	SO780	-5250.5	260	1170	SO868	-6746.5	260	1258	SO956	-8242.5	260
1007	SO605	-2275.5	120	1015	SO693	3771.5	120	1113	SO781	-5267.5	120	1171	SO869	-6763.5	120	1259	SO957	-8259.5	120
1008	SO606	-2292.5	260	1016	SO694	3788.5	260	1114	SO782	-5284.5	260	1172	SO870	-6780.5	260	1260	SO958	-8276.5	260
1009	SO607	-2309.5	120	1017	SO695	3805.5	120	1115	SO783	-5301.5	120	1173	SO871	-6797.5	120	1261	SO959	-8293.5	120
1010	SO608	-2326.5	260	1018	SO696	3822.5	260	1116	SO784	-5318.5	260	1174	SO872	-6814.5	260	1262	SO960	-8310.5	260
1011	SO609	-2343.5	120	1019	SO697	3839.5	120	1117	SO785	-5335.5	120	1175	SO873	-6831.5	120	1263	COM1_R	-8327.5	260
1012	SO610	-2360.5	260	1020	SO698	3856.5	260	1118	SO786	-5352.5	260	1176	SO874	-6848.5	260	1264	COM1_R	-8344.5	260
1013	SO611	-2377.5	120	1021	SO699	3873.5	120	1119	SO787	-5369.5	120	1177	SO875	-6865.5	120	1265	COM1_R	-8361.5	260
1014	SO612	-2394.5	260	1022	SO700	3890.5	260	1120	SO788	-5386.5	260	1178	SO876	-6882.5	260	1266	COM1_R	-8378.5	260
1015	SO613	-2411.5	120	1023	SO701	3907.5	120	1121	SO789	-5403.5	120	1179	SO877	-6899.5	120	1267	COM1_R	-8395.5	260
1016	SO614	-2428.5	260	1024	SO702	3924.5	260	1122	SO790	-5420.5	260	1180	SO878	-6916.5	260	1268	COM1_R	-8412.5	260
1017	SO615	-2445.5	120	1025	SO703	3941.5	120	1123	SO791	-5437.5	120	1181	SO879	-6933.5	120	1269	COM1_R	-8429.5	260
1018	SO616	-2462.5	260	1026	SO704	3958.5	260	1124	SO792	-5454.5	260	1182	SO880	-6950.5	260	1270	COM1_R	-8446.5	260
1019	SO617	-2479.5	120	1027	SO705	3975.5	120	1125	SO793	-5471.5	120	1183	SO881	-6967.5	120	1271	COM1_R	-8463.5	260
1020	SO618	-2496.5	260	1028	SO706	3992.5	260	1126	SO794	-5488.5	260	1184	SO882	-6984.5	260	1272	COM1_R	-8480.5	260
1021	SO619	-2513.5	120	1029	SO707	4009.5	120	1127	SO795	-5505.5	120	1185	SO883	-7001.5	120	1273	COM1_R	-8497.5	260
1022	SO620	-2530.5	260	1030	SO708	4026.5	260	1128	SO796	-5522.5	260	1186	SO884	-7018.5	260	1274	COM1_R	-8514.5	260
1023	SO621	-2547.5	120	1031	SO709	4043.5	120	1129	SO797	-5539.5	120	1187	SO885	-7035.5	120	1275	COM1_R	-8531.5	120
1024	SO622	-2564.5	260	1032	SO710	4060.5	260	1130	SO798	-5556.5	260	1188	SO886	-7052.5	260	1276	COM1_R	-8548.5	120
1025	SO623	-2581.5	120	1033	SO711	4077.5	120	1131	SO799	-5573.5	120	1189	SO887	-7069.5	120	1277	COM1_R	-8565.5	120
1026	SO624	-2598.5	260	1034	SO712	4094.5	260	1132	SO800	-5590.5	260	1190	SO888	-7086.5	260	1278	COM1_R	-8582.5	120
1027	SO625	-2615.5	120	1035	SO713	4111.5	120	1133	SO801	-5607.5	120	1191	SO889	-7103.5	120	1279	COM1_R	-8599.5	120
1028	SO626	-2632.5	260	1036	SO714	4128.5	260	1134	SO802	-5624.5	260	1192	SO890	-7120.5	260	1280	COM1_R	-8616.5	120
1029	SO627	-2649.5	120	1037	SO715	4145.5	120	1135	SO803	-5641.5	120	1193	SO891	-7137.5	120	1281	COM1_R	-8633.5	120
1030	SO628	-2666.5	260	1038	SO716	4162.5	260	1136	SO804	-5658.5	260	1194	SO892	-7154.5	260	1282	COM1_R	-8650.5	120
1031	SO629	-2683.5	120	1039	SO717	4179.5	120	1137	SO805	-5675.5	120	1195	SO893	-7171.5	120	1283	COM1_R	-8667.5	120
1032	SO630	-2700.5	260	1040	SO718	4196.5	260	1138	SO806	-5692.5	260	1196	SO894	-7188.5	260	1284	COM1_R	-8684.5	120
1033	SO631	-2717.5	120	1041	SO719	4213.5	120	1139	SO807	-5709.5	120	1197	SO895	-7205.5	120	1285	COM1_R	-8701.5	120
1034	SO632	-2734.5	260	1042	SO720	4230.5	260	1140	SO808	-5726.5	260	1198	SO896	-7222.5	260	1286	COM1_R	-8718.5	120
1035	SO633	-2751.5	120	1043	SO721	4247.5	120	1141	SO809	-5743.5	120	1199	SO897	-7239.5	120	1287	COM1_R	-8735.5	120
1036	SO634	-2768.5	260	1044	SO722	4264.5	260	1142	SO810	-5760.5	260	1200	SO898	-7256.5	260	1288	COM1_R	-8752.5	120
1037	SO635	-2785.5	120	1045	SO723	4281.5	120	1143	SO811	-5777.5	120	1201	SO899	-7273.5	120	1289	COM1_R	-8769.5	120
1038	SO636	-2802.5	260	1046	SO724	4298.5	260	1144	SO812	-5794.5	260	1202	SO900	-7290.5	260	1290	COM1_R	-8786.5	120
1039	SO637	-2819.5	120	1047	SO725	4315.5	120	1145	SO813	-5811.5	120	1203	SO901	-7307.5	120	1291	COM1_R	-8803.5	120
1040	SO638	-2836.5	260	1048	SO726	4332.5	260	1146	SO814	-5828.5	260	1204	SO902	-7324.5	260	1292	COM1_R	-8820.5	120
1041	SO639	-2853.5	120	1049	SO727	4349.5	120	1147	SO815	-5845.5	120	1205	SO903	-7341.5	120	1293	COM1_R	-8837.5	120
1042	SO640	-2870.5	260	1050	SO728	4366.5	260	1148	SO816	-5862.5	260	1206	SO904	-7358.5	260	1294	COM1_R	-8854.5	120
1043	SO641	-2887.5	120	1051	SO729	4383.5	120	1149	SO817	-5879.5	120	1207	SO905	-7375.5	120	1295	COM1_R	-8871.5	120
1044	SO642	-2904.5	260	1052	SO730	4400.5	260	1150	SO818	-5896.5	260	1208	SO906	-7392.5	260	1296	COM1_R	-8888	

Pad No.	Name	X	Y
1321	GO133	-9425.5	120
1322	GO131	-9442.5	260
1323	GO129	-9459.5	120
1324	GO127	-9476.5	260
1325	GO125	-9493.5	120
1326	GO123	-9510.5	260
1327	GO121	-9527.5	120
1328	GO119	-9544.5	260
1329	GO117	-9561.5	120
1330	GO115	-9578.5	260
1331	GO113	-9595.5	120
1332	GO111	-9612.5	260
1333	GO109	-9629.5	120
1334	GO107	-9646.5	260
1335	GO105	-9663.5	120
1336	GO103	-9680.5	260
1337	GO101	-9697.5	120
1338	GO99	-9714.5	260
1339	GO97	-9731.5	120
1340	GO95	-9748.5	260
1341	GO93	-9765.5	120
1342	GO91	-9782.5	260
1343	GO89	-9799.5	120
1344	GO87	-9816.5	260
1345	GO85	-9833.5	120
1346	GO83	-9850.5	260
1347	GO81	-9867.5	120
1348	GO79	-9884.5	260
1349	GO77	-9901.5	120
1350	GO75	-9918.5	260
1351	GO73	-9935.5	120
1352	GO71	-9952.5	260
1353	GO69	-9969.5	120
1354	GO67	-9986.5	260
1355	GO65	-10003.5	120
1356	GO63	-10020.5	260
1357	GO61	-10037.5	120
1358	GO59	-10054.5	260
1359	GO57	-10071.5	120
1360	GO55	-10088.5	260
1361	GO53	-10105.5	120
1362	GO51	-10122.5	260
1363	GO49	-10139.5	120
1364	GO47	-10156.5	260
1365	GO45	-10173.5	120
1366	GO43	-10190.5	260
1367	GO41	-10207.5	120
1368	GO39	-10224.5	260
1369	GO37	-10241.5	120
1370	GO35	-10258.5	260
1371	GO33	-10275.5	120
1372	GO31	-10292.5	260
1373	GO29	-10309.5	120
1374	GO27	-10326.5	260
1375	GO25	-10343.5	120
1376	GO23	-10360.5	260
1377	GO21	-10377.5	120
1378	GO19	-10394.5	260
1379	GO17	-10411.5	120
1380	GO15	-10428.5	260
1381	GO13	-10445.5	120
1382	GO11	-10462.5	260
1383	GO9	-10479.5	120
1384	GO7	-10496.5	260
1385	GO5	-10513.5	120
1386	GO3	-10530.5	260
1387	GO1	-10547.5	120
1388	DUM	-10564.5	260

NOVATEK CONFIDENTIAL  
NOT DISCLOSURE