

NC7SZ19

TinyLogic® UHS 1-of-2 Decoder/Demultiplexer

General Description

The NC7SZ19 is a 1-of-2 decoder with a common output enable. The device is fabricated with advanced CMOS technology to achieve ultra high speed with high output drive while maintaining low static power dissipation over a broad V_{CC} operating range. The device is specified to operate over the 1.65V to 5.5V V_{CC} operating range. The inputs and outputs are high impedance when V_{CC} is 0V. Inputs tolerate voltages up to 5.5V independent of V_{CC} operating range.

Features

- Space saving SC70 6-lead surface mount package
- Ultra small MicroPak™ leadless package
- Ultra High Speed: t_{PD} 2.7 ns Typ into 50 pF at 5V V_{CC}
- Broad V_{CC} Operating Range; 1.65V to 5.5V
- Power down high impedance inputs/outputs
- Overvoltage tolerant inputs facilitate 5V to 3V translation
- Patented noise/EMI reduction circuitry implemented

Ordering Code:

Order Number	Package Number	Product Code Top Mark	Package Description	Supplied As
NC7SZ19P6X	MAA06A	Z19	6-Lead SC70, EIAJ SC88, 1.25mm Wide	3k Units on Tape and Reel
NC7SZ19L6X	MAC06A	B4	6-Lead MicroPak, 1.0mm Wide	5k Units on Tape and Reel

Pin Descriptions

Pin Names	Description
\bar{E}	Decoder Output Enable/ Demultiplexer Data
A	Decoder Address/Demultiplexer Select
Y_0, Y_1	Outputs

Function Table

Input		Output	
A	\bar{E}	$Y_0 = A + \bar{E}$	$Y_1 = \bar{A} + \bar{E}$
L	L	L	H
H	L	H	L
X	H	H	H

H = HIGH Logic Level
L = LOW Logic Level
X = Don't Care

Connection Diagrams

Pin Assignments for SC70

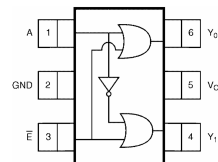

(Top View)

Pin One Orientation Diagram

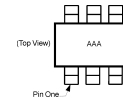

AAA = Product Code Top Mark - see ordering code

Note: Orientation of Top Mark determines Pin One location. Read the top product code mark left to right, Pin One is the lower left pin (see diagram).

Pad Assignments for MicroPak

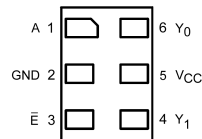

(Top Thru View)

TinyLogic® is a registered trademark of Fairchild Semiconductor Corporation.
MicroPak™ is a trademark of Fairchild Semiconductor Corporation.

NC7SZ19 TinyLogic® UHS 1-of-2 Decoder/Demultiplexer

Absolute Maximum Ratings(Note 1)

Supply Voltage (V _{CC})	-0.5V to +7.0V
DC Input Voltage (V _{IN})	-0.5V to +7.0V
DC Output Voltage (V _{OUT})	-0.5V to +7.0V
DC Input Diode Current (I _{IK})	
@ V _{IN} ≤ -0.5V	-50 mA
DC Output Diode Current (I _{OK})	
@ V _{IN} ≤ -0.5V	-50 mA
DC Output Current (I _{OUT})	±50 mA
DC V _{CC} or Ground Current (I _{CC} /I _{GND})	±100 mA
Storage Temperature Range (T _{STG})	-65°C to +150°C
Junction Temperature under Bias (T _J)	150°C
Junction Lead Temperature (T _L)	
(Soldering, 10 seconds)	260°C
Power Dissipation (P _D) @ +85°C	180 mW

Recommended Operating Conditions

Supply Voltage Operating (V _{CC})	1.65V to 5.5V
Supply Voltage Data Retention (V _{CC})	1.5V to 5.5V
Input Voltage (V _{IN})	0V to 5.5V
Output Voltage (V _{OUT})	0V to V _{CC}
Operating Temperature (T _A)	-40°C to +85°C
Input Rise and Fall Time (t _r , t _f)	
V _{CC} @ 1.8V ± 0.15V, 2.5V ± 0.2V	0 ns/V to 20 ns/V
V _{CC} @ 3.3V ± 0.3V	0 ns/V to 10 ns/V
V _{CC} @ 5.0V ± 0.5V	0 ns/V to 5 ns/V
Thermal Resistance (θ _{JA})	350°C/W

Note 1: Absolute maximum ratings are DC values beyond which the device may be damaged or have its useful life impaired. The datasheet specifications should be met, without exception, to ensure that the system design is reliable over its power supply, temperature, and output/input loading variables. Fairchild does not recommend operation outside datasheet specifications.

DC Electrical Characteristics

Symbol	Parameter	V _{CC} (V)	T _A = +25°C			T _A = -40°C to +85°C		Units	Conditions	
			Min	Typ	Max	Min	Max			
V _{IH}	HIGH Level Input Voltage	1.65 2.3 – 5.5	0.75 V _{CC} 0.7 V _{CC}			0.75 V _{CC} 0.7 V _{CC}	V			
V _{IL}	LOW Level Input Voltage	1.65 2.3 – 5.5				0.25 V _{CC} 0.3 V _{CC}	V			
V _{OH}	HIGH Level Output Voltage	1.65	1.55	1.65		1.55	V	V _{IN} = V _{IH} or V _{IL}	I _{OH} = -100 μA	
		2.3	2.2	2.3		2.2				
		3.0	2.9	3.0		2.9				
		4.5	4.4	4.5		4.4				
		1.65	1.29	1.52		1.29				
		2.3	1.9	2.15		1.9				
		3.0	2.4	2.80		2.4				
3.0	2.3	3.68		2.3						
4.5	3.8	4.20		3.8						
V _{OL}	LOW Level Output Voltage	1.65		0.0	0.10		0.10	V	V _{IN} = V _{IL} or V _{IH}	I _{OL} = 100 μA
		2.3		0.0	0.10		0.10			
		3.0		0.0	0.10		0.10			
		4.5		0.0	0.10		0.10			
		1.65		0.08	0.24		0.24			
		2.3		0.10	0.3		0.3			
		3.0		0.15	0.4		0.4			
3.0		0.22	0.55		0.55					
4.5		0.22	0.55		0.55					
I _{IN}	Input Leakage Current	0 to 5.5				±0.1	±1	μA	V _{IN} = 5.5V, GND	
I _{OFF}	Power Off Leakage Current	0.0				1	10	μA	V _{IN} or V _{OUT} = 5.5V	
I _{CC}	Quiescent Supply Current	1.65 to 5.5				1	10	μA	V _{IN} = 5.5V, GND	

AC Electrical Characteristics

Symbol	Parameter	V _{CC} (V)	T _A = +25°C			T _A = -40°C to +85°C		Units	Conditions	Figure Number
			Min	Typ	Max	Min	Max			
t _{PLH}	Propagation Delay A or \bar{E} to Output	1.8 ± 0.15	2.5	5.9	10.5	2.5	11.0	ns	C _L = 15 pF, R _L = 1 MΩ	Figures 1, 3
t _{PHL}		2.5 ± 0.2	1.2	3.5	6.0	1.2	6.4			
		3.3 ± 0.3	0.8	2.7	4.1	0.8	4.5			
		5.0 ± 0.5	0.5	2.1	3.2	0.5	3.5			
t _{PLH}	Propagation Delay A or \bar{E} to Output	3.3 ± 0.3	1.2	3.2	5.1	1.2	5.4	ns	C _L = 50 pF, R _L = 500Ω	Figures 1, 3
t _{PHL}		5.0 ± 0.5	0.8	2.7	4.0	0.8	4.3			
C _{IN}	Input Capacitance	0	2.3					pF		
C _{PD}	Power Dissipation	3.3	10.5					pF	(Note 2)	Figure 2
	Capacitance	5.0	12.8							

Note 2: C_{PD} is defined as the value of the internal equivalent capacitance which is derived from dynamic operating current consumption (I_{CCD}) at no output loading and operating at 50% duty cycle. (See Figure 2.) C_{PD} is related to I_{CCD} dynamic operating current by the expression:
 $I_{CCD} = (C_{PD})(V_{CC})(f_{IN}) + I_{CCstatic}$.

AC Loading and Waveforms

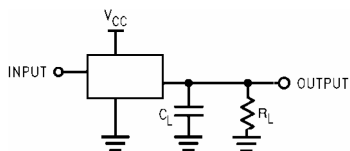

C_L includes load and stray capacitance
 Input PRR = 1.0 MHz; t_W = 500 ns

FIGURE 1. AC Test Circuit

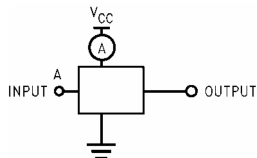

Input = AC Waveform; t_r = t_f = 1.8 ns
 PRR = 10 MHz; Duty Cycle = 50%
 \bar{E} Input = GND

FIGURE 2. I_{CCD} Test Circuit

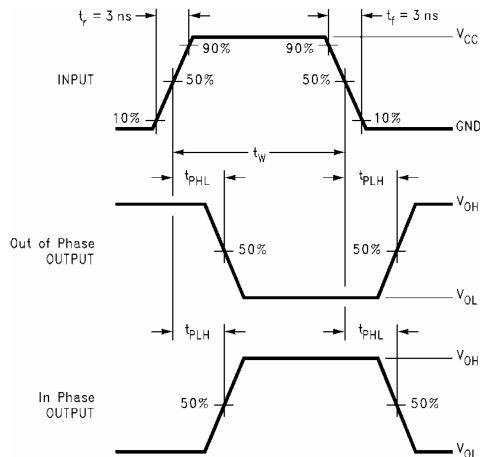

FIGURE 3. AC Waveforms

NC7SZ19

Tape and Reel Specification

TAPE FORMAT for SC70

Package Designator	Tape Section	Number Cavities	Cavity Status	Cover Tape Status
P6X	Leader (Start End)	125 (typ)	Empty	Sealed
	Carrier	3000	Filled	Sealed
	Trailer (Hub End)	75 (typ)	Empty	Sealed

TAPE DIMENSIONS inches (millimeters)

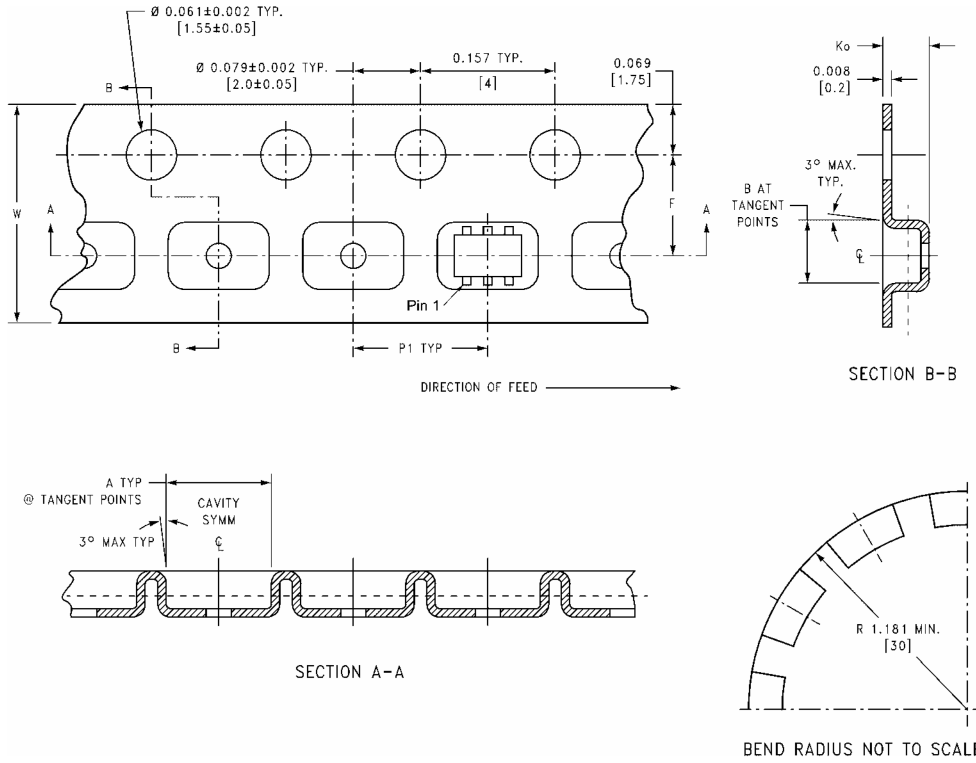

Package	Tape Size	DIM A	DIM B	DIM F	DIM K _o	DIM P1	DIM W
SC70-6	8 mm	0.093 (2.35)	0.096 (2.45)	0.138 ± 0.004 (3.5 ± 0.10)	0.053 ± 0.004 (1.35 ± 0.10)	0.157 (4)	0.315 ± 0.004 (8 ± 0.1)

Tape and Reel Specification (Continued)

TAPE FORMAT for MicroPak

Package Designator	Tape Section	Number Cavities	Cavity Status	Cover Tape Status
L6X	Leader (Start End)	125 (typ)	Empty	Sealed
	Carrier	5000	Filled	Sealed
	Trailer (Hub End)	75 (typ)	Empty	Sealed

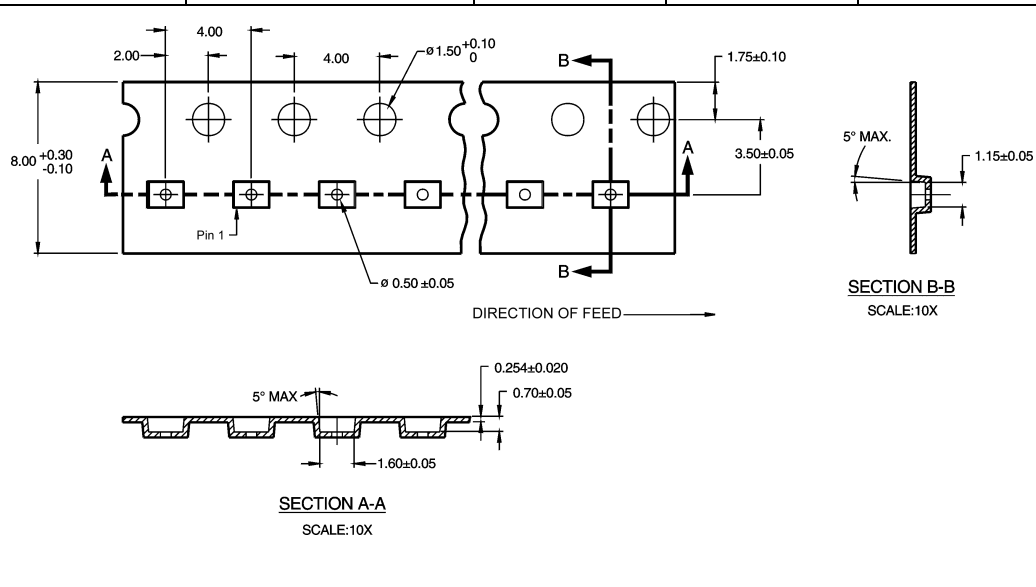

REEL DIMENSIONS inches (millimeters)

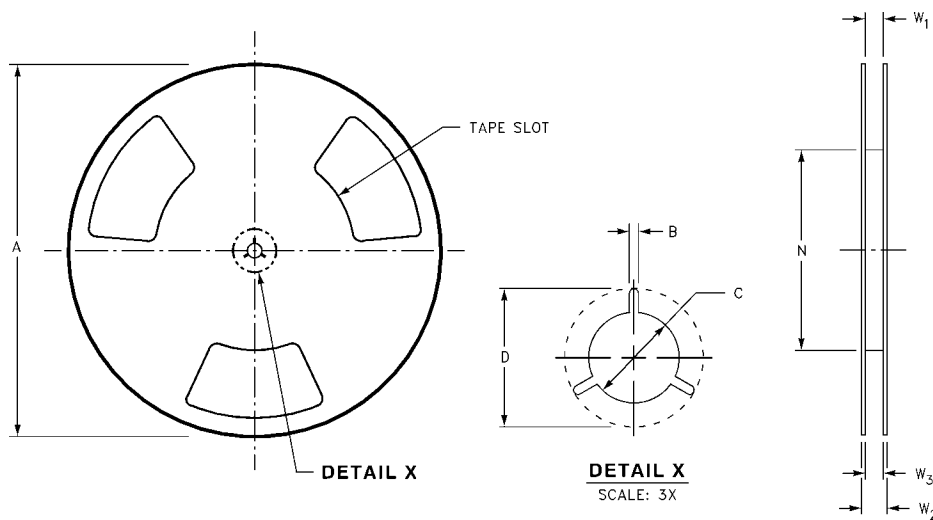

Tape Size	A	B	C	D	N	W1	W2	W3
8 mm	7.0 (177.8)	0.059 (1.50)	0.512 (13.00)	0.795 (20.20)	2.165 (55.00)	0.331 + 0.059/-0.000 (8.40 + 1.50/-0.00)	0.567 (14.40)	W1 + 0.078/-0.039 (W1 + 2.00/-1.00)

NC7SZ19

Physical Dimensions inches (millimeters) unless otherwise noted

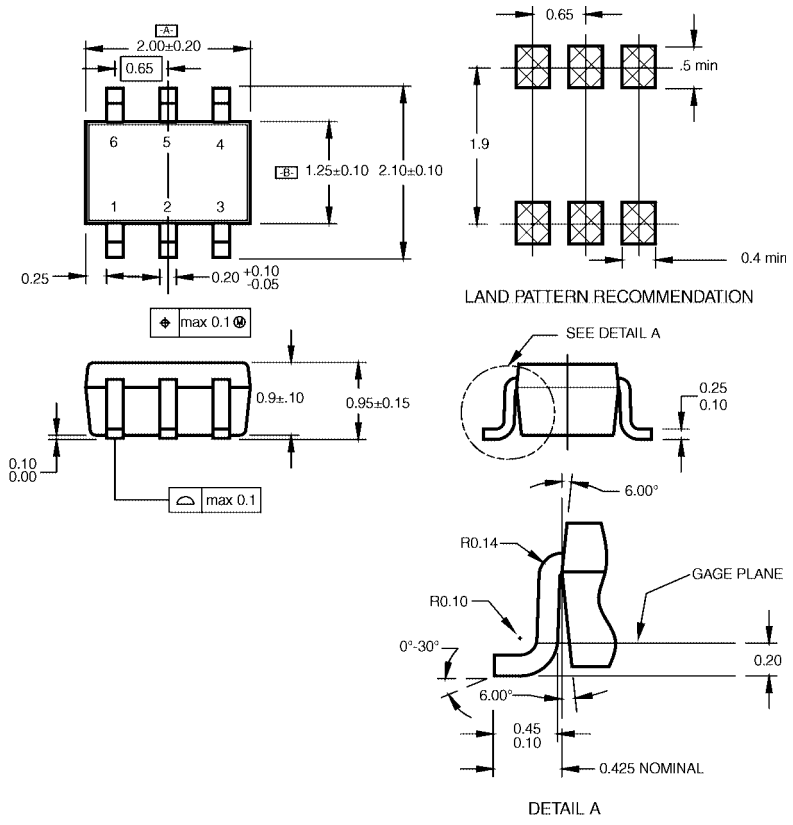

NOTES:
 A. CONFORMS TO EIAJ REGISTERED OUTLINE DRAWING SC88.
 B. DIMENSIONS DO NOT INCLUDE BURRS OR MOLD FLASH.
 C. DIMENSIONS ARE IN MILLIMETERS.

MAA06ARevC

**6-Lead SC70, EIAJ SC88, 1.25mm Wide
 Package Number MAA06A**

Physical Dimensions inches (millimeters) unless otherwise noted (Continued)

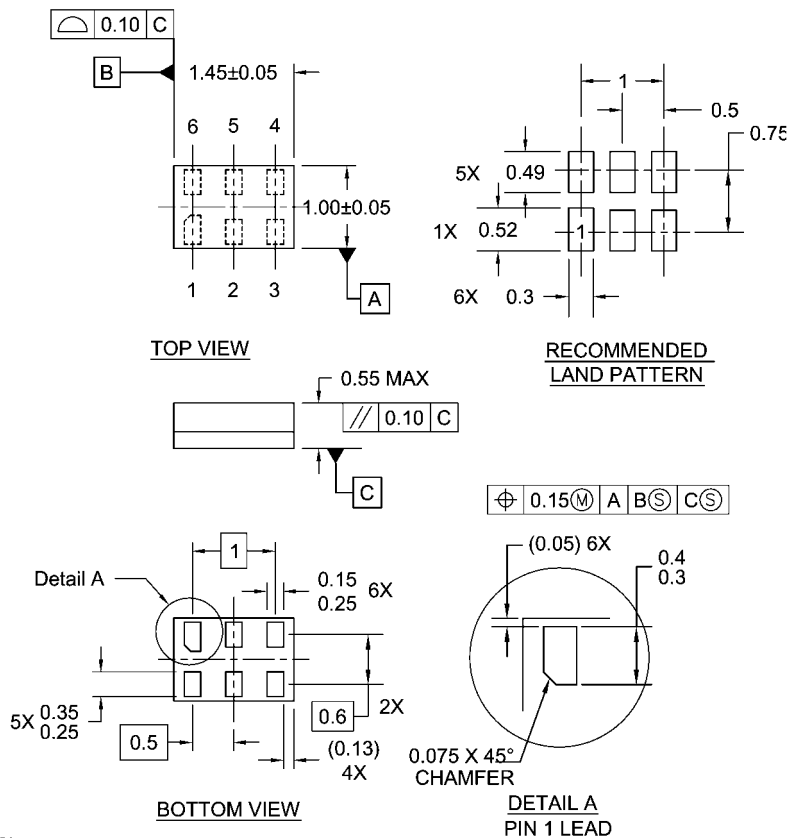

Notes:

1. JEDEC PACKAGE REGISTRATION IS ANTICIPATED
2. DIMENSIONS ARE IN MILLIMETERS
3. DRAWING CONFORMS TO ASME Y14.5M-1994

MAC06ARevB

**6-Lead MicroPak, 1.0mm Wide
Package Number MAC06A**

Fairchild does not assume any responsibility for use of any circuitry described, no circuit patent licenses are implied and Fairchild reserves the right at any time without notice to change said circuitry and specifications.

LIFE SUPPORT POLICY

FAIRCHILD'S PRODUCTS ARE NOT AUTHORIZED FOR USE AS CRITICAL COMPONENTS IN LIFE SUPPORT DEVICES OR SYSTEMS WITHOUT THE EXPRESS WRITTEN APPROVAL OF THE PRESIDENT OF FAIRCHILD SEMICONDUCTOR CORPORATION. As used herein:

1. Life support devices or systems are devices or systems which, (a) are intended for surgical implant into the body, or (b) support or sustain life, and (c) whose failure to perform when properly used in accordance with instructions for use provided in the labeling, can be reasonably expected to result in a significant injury to the user.
2. A critical component in any component of a life support device or system whose failure to perform can be reasonably expected to cause the failure of the life support device or system, or to affect its safety or effectiveness.

www.fairchildsemi.com