

## NC7SZ175 TinyLogic® UHS D-Type Flip-Flop with Asynchronous Clear

### General Description

The NC7SZ175 is a single positive edge-triggered D-type CMOS Flip-Flop with Asynchronous Clear from Fairchild's Ultra High Speed Series of TinyLogic® in the space saving SC70 6-lead package. The device is fabricated with advanced CMOS technology to achieve ultra high speed with high output drive while maintaining low static power dissipation over a very broad  $V_{CC}$  operating range. The device is specified to operate over the 1.65V to 5.5V  $V_{CC}$  range. The inputs and output are high impedance when  $V_{CC}$  is 0V. Inputs tolerate voltages up to 7V independent of  $V_{CC}$  operating voltage. This single flip-flop will store the state of the D input that meets the setup and hold time requirements on the LOW-to-HIGH Clock (CP) transition. A LOW input to Clear sets the Q output to LOW level. The Clear input is independent of clock.

### Features

- Space saving SC70 6-lead package
- Ultra small MicroPak™ leadless package
- Ultra High Speed;  $t_{PD}$  2.6 ns Typ into 50 pF at 5V  $V_{CC}$
- High Output Drive;  $\pm 24$  mA at 3V  $V_{CC}$
- Broad  $V_{CC}$  Operating Range; 1.65V to 5.5V
- Matches the performance of LCX when operated at 3.3V  $V_{CC}$
- Power down high impedance inputs/output
- Overvoltage tolerant inputs facilitate 5V to 3V translation
- Patented noise/EMI reduction circuitry implemented

### Ordering Code:

Order Number	Package Number	Product Code Top Mark	Package Description	Supplied As
NC7SZ175P6X	MAA06A	Z75	6-Lead SC70, EIAJ SC88, 1.25mm Wide	3k Units on Tape and Reel
NC7SZ175L6X	MAC06A	C4	6-Lead MicroPak, 1.0mm Wide	5k Units on Tape and Reel

TinyLogic® is a registered trademark of Fairchild Semiconductor Corporation.  
MicroPak™ is a trademark of Fairchild Semiconductor Corporation.

**Logic Symbol**

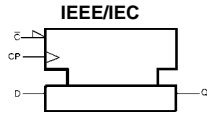

**Function Table**

Inputs			Output
CP	D	C̄	Q
~	L	H	L
~	H	H	H
~	X	H	Qn
X	X	L	L

H = HIGH Logic Level    Qn = No change in data  
 L = LOW Logic Level    X = Immaterial

**Pin Descriptions**

Pin Names	Description
D	Data Input
CP	Clock Pulse Input
C̄	Clear Input
Q	Flip-Flop Output

**Connection Diagrams**

**Pin Assignments for SC70**

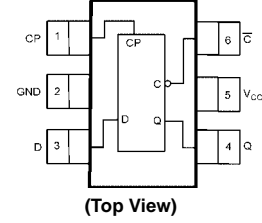

**Pin One Orientation Diagram**

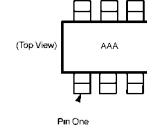

AAA represents Product Code Top Mark - see ordering code

**Note:** Orientation of Top Mark determines Pin One location. Read the top product code mark left to right, Pin One is the lower left pin (see diagram).

**Pad Assignments for MicroPak**

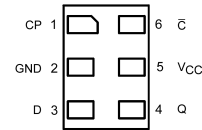

Absolute Maximum Ratings (Note 1)		Recommended Operating Conditions (Note 2)	
Supply Voltage ( $V_{CC}$ )	-0.5V to +7.0V	Power Supply	Operating ( $V_{CC}$ ) 1.65V to 5.5V
DC Input Voltage ( $V_{IN}$ )	-0.5V to +7.0V	Data Retention	1.5V to 5.5V
DC Output Voltage ( $V_{OUT}$ )	-0.5V to +7.0V	Input Voltage ( $V_{IN}$ )	0V to 5.5V
DC Input Diode Current ( $I_{IK}$ )		Output Voltage ( $V_{OUT}$ )	0V to $V_{CC}$
$V_{IN} < 0V$	-50 mA	Input Rise and Fall Time ( $t_r, t_f$ )	
DC Output Diode Current ( $I_{OK}$ )		$V_{CC} = 1.8V, 2.5V \pm 0.2V$	0 to 20 ns/V
$V_{OUT} < 0V$	-50 mA	$V_{CC} = 3.3V \pm 0.3V$	0 to 10 ns/V
DC Output ( $I_{OUT}$ ) Source/Sink Current	$\pm 50$ mA	$V_{CC} = 5.5V \pm 0.5V$	0 to 5 ns/V
DC $V_{CC}/GND$ Current ( $I_{CC}/I_{GND}$ )	$\pm 50$ mA	Operating Temperature ( $T_A$ )	-40°C to +85°C
Storage Temperature Range ( $T_{STG}$ )	-65°C to +150°C	Thermal Resistance ( $\theta_{JA}$ )	350° C/W
Junction Temperature under Bias ( $T_J$ )	150°C	<b>Note 1:</b> The "Absolute Maximum Ratings": are those values beyond which the safety of the device cannot be guaranteed. The device should not be operated at these limits. The parametric values defined in the Electrical Characteristics tables are not guaranteed at the absolute maximum ratings. The "Recommended Operating Conditions" table will define the conditions for actual device operation.	
Junction Lead Temperature ( $T_L$ ) (Soldering, 10 seconds)	260°C	<b>Note 2:</b> Unused inputs must be held HIGH or LOW. They may not float.	
Power Dissipation ( $P_D$ ) @+85°C	180 mW		

### DC Electrical Characteristics

Symbol	Parameter	$V_{CC}$ (V)	$T_A = +25^\circ C$			$T_A = -40^\circ C$ to $+85^\circ C$		Unit	Conditions
			Min	Typ	Max	Min	Max		
$V_{IH}$	HIGH Level Control Input Voltage	1.65 to 1.95 2.3 to 5.5	0.75 $V_{CC}$ 0.7 $V_{CC}$			0.75 $V_{CC}$ 0.7 $V_{CC}$		V	
$V_{IL}$	LOW Level Control Input Voltage	1.65 to 1.95 2.3 to 5.5	0.25 $V_{CC}$ 0.3 $V_{CC}$			0.25 $V_{CC}$ 0.3 $V_{CC}$		V	
$V_{OH}$	HIGH Level Control Output Voltage	1.65	1.55	1.65	1.55		V	$V_{IN} = V_{IH}$ or $V_{IL}$	$I_{OH} = -100 \mu A$
		1.8	1.7	1.8	1.7				
		2.3	2.2	2.3	2.2				
		3.0	2.9	3.0	2.9				
		4.5	4.4	4.5	4.4				
		1.65	1.24	1.52	1.29				$I_{OH} = -4 \text{ mA}$ $I_{OH} = -8 \text{ mA}$ $I_{OH} = -16 \text{ mA}$ $I_{OH} = -24 \text{ mA}$ $I_{OH} = -32 \text{ mA}$
		2.3	1.9	2.15	1.9				
		3.0	2.4	2.8	2.4				
		3.0	2.3	2.68	2.3				
		4.5	3.8	4.2	3.8				
$V_{OL}$	LOW Level Control Output Voltage	1.65	0.0		0.1		V	$V_{IN} = V_{IL}$ or $V_{IH}$	$I_{OL} = 100 \mu A$
		1.8	0.0		0.1				
		2.3	0.0		0.1				
		3.0	0.0		0.1				
		4.5	0.0		0.1				
		1.65	0.08		0.24				$I_{OL} = 4 \text{ mA}$ $I_{OL} = 8 \text{ mA}$ $I_{OL} = 16 \text{ mA}$ $I_{OL} = 24 \text{ mA}$ $I_{OL} = 32 \text{ mA}$
		2.3	0.10		0.3				
		3.0	0.15		0.4				
3.0	0.22		0.55						
4.5	0.22		0.55						
$I_{IN}$	Input Leakage Current	0 to 5.5			$\pm 0.1$		$\mu A$	$0 \leq V_{IN} \leq 5.5V$	
$I_{OFF}$	Power Off Leakage Current	0.0			1.0		$\mu A$	$V_{IN}$ or $V_{OUT} = 5.5V$	
$I_{CC}$	Quiescent Supply Current	1.65 to 5.5			1.0		$\mu A$	$V_{IN} = 5.5V, GND$	

AC Electrical Characteristics										
Symbol	Parameter	V <sub>CC</sub> (V)	T <sub>A</sub> = +25°C			T <sub>A</sub> = -40°C to +85°C		Units	Conditions	Figure Number
			Min	Typ	Max	Min	Max			
f <sub>MAX</sub>	Maximum Clock Frequency	1.65				100		MHz	C <sub>L</sub> = 50 pF R <sub>L</sub> = 500 Ω	Figures 1, 4
		1.8				100				
		2.5 ± 0.2				125				
		3.3 ± 0.3				150				
		5.0 ± 0.5				175				
t <sub>PLH</sub> t <sub>PHL</sub>	Propagation Delay CP to Q	1.65	2.5	9.8	15.0	2.5	16.5	ns	C <sub>L</sub> = 15 pF R <sub>L</sub> = 1 MΩ	Figures 1, 3
		1.8	2.5	6.5	10.0	2.5	11.0			
		2.5 ± 0.2	2.0	3.8	6.5	2.0	7.0			
		3.3 ± 0.3	1.5	2.8	4.5	1.4	5.0			
		5.0 ± 0.5	1.0	2.2	3.5	1.0	3.8			
		3.3 ± 0.3	2.0	3.4	5.5	1.6	6.2		C <sub>L</sub> = 50 pF R <sub>L</sub> = 500 Ω	Figures 1, 3
		5.0 ± 0.5	1.5	2.6	4.0	1.4	4.7			
t <sub>PHL</sub>	Propagation Delay $\overline{C}$ to Q	1.65	2.5	9.8	13.5	2.5	15.0	ns	C <sub>L</sub> = 15 pF R <sub>L</sub> = 1 MΩ	Figures 1, 3
		1.8	2.5	6.5	9.0	2.5	10.0			
		2.5 ± 0.2	2.0	3.8	6.0	2.0	6.4			
		3.3 ± 0.3	1.5	2.8	4.3	1.2	4.6			
		5.0 ± 0.5	1.5	2.2	3.2	1.0	3.5			
		3.3 ± 0.3	1.5	3.4	5.3	1.5	5.8		C <sub>L</sub> = 50 pF R <sub>L</sub> = 500 Ω	Figures 1, 3
		5.0 ± 0.5	1.0	2.7	4.0	1.2	4.5			
t <sub>S</sub>	Setup Time CP to D	2.5 ± 0.2				2.5		ns	C <sub>L</sub> = 50 pF R <sub>L</sub> = 500 Ω	Figures 1, 4
		3.3 ± 0.3				2.0				
		5.0 ± 0.5				1.5				
t <sub>H</sub>	Hold Time, CP to D	2.5 ± 0.2				1.5		ns	C <sub>L</sub> = 50 pF R <sub>L</sub> = 500 Ω	Figures 1, 4
		3.3 ± 0.3				1.5				
		5.0 ± 0.5				1.5				
t <sub>W</sub>	Pulse Width, CP	2.5 ± 0.2				3.0		ns	C <sub>L</sub> = 50 pF R <sub>L</sub> = 500 Ω	Figures 1, 4
		3.3 ± 0.3				2.8				
		5.0 ± 0.5				2.5				
	Pulse Width, $\overline{C}$	2.5 ± 0.2				3.0		ns	Clock HIGH or LOW C <sub>L</sub> = 50 pF R <sub>L</sub> = 500 Ω	Figures 1, 4
		3.3 ± 0.3				2.8				
		5.0 ± 0.5				2.5				
t <sub>rec</sub>	Recovery Time, $\overline{C}$ to CP	2.5 ± 0.2				1.0		ns	C <sub>L</sub> = 50 pF R <sub>L</sub> = 500 Ω	Figures 1, 4
		3.3 ± 0.3				1.0				
		5.0 ± 0.5				1.0				

  

Capacitance (Note 3)					
Symbol	Parameter	Typ	Max	Units	Conditions
C <sub>IN</sub>	Input Capacitance	3		pF	V <sub>CC</sub> = Open, V <sub>IN</sub> = 0V or V <sub>CC</sub>
C <sub>OUT</sub>	Output Capacitance	4		pF	V <sub>CC</sub> = 3.3V, V <sub>IN</sub> = 0V or V <sub>CC</sub>
C <sub>PD</sub>	Power Dissipation Capacitance (Note 4)	10		pF	V <sub>CC</sub> = 3.3V
		12			V <sub>CC</sub> = 5.0V

**Note 3:** T<sub>A</sub> = +25°C, f = 1MHz.

**Note 4:** C<sub>PD</sub> is defined as the value of the internal equivalent capacitance which is derived from dynamic operating current consumption (I<sub>CCD</sub>) at no output loading and operating at 50% duty cycle. (See Figure 2)  
C<sub>PD</sub> is related to I<sub>CCD</sub> dynamic operating current by the expression: I<sub>CCD</sub> = (C<sub>PD</sub>)(V<sub>CC</sub>)(f<sub>IN</sub>) + (I<sub>CCstatic</sub>).

## AC Loading and Waveforms

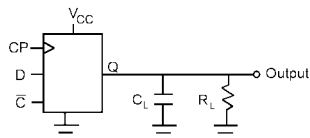

$C_L$  includes load and stray capacitance  
 Input PRR = 1.0 MHz,  $t_w = 500$  ns

**FIGURE 1. AC Test Circuit**

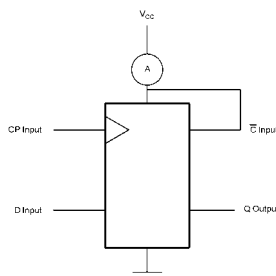

CP Input = AC Waveform;  $t_r = t_f = 1.8$  ns;  
 CP Input PRR = 10 MHz; Duty Cycle = 50%  
 D Input PRR = 5MHz; Duty Cycle = 50%

**FIGURE 2.  $I_{CCD}$  Test Circuit**

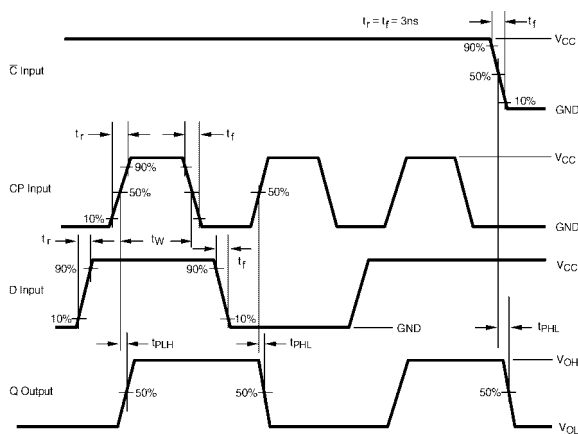

**FIGURE 3. AC Waveforms**

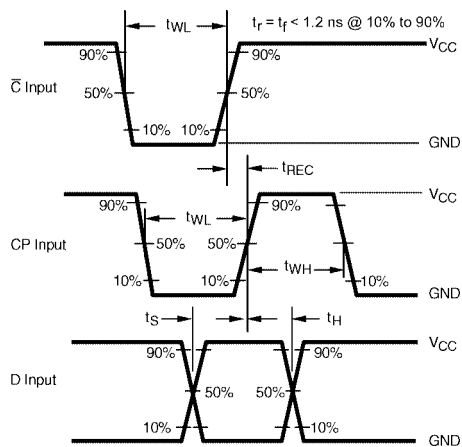

**FIGURE 4. AC Waveforms**

## Tape and Reel Specification

### TAPE FORMAT for SC70

Package Designator	Tape Section	Number Cavities	Cavity Status	Cover Tape Status
P6X	Leader (Start End)	125 (typ)	Empty	Sealed
	Carrier	3000	Filled	Sealed
	Trailer (Hub End)	75 (typ)	Empty	Sealed

### TAPE DIMENSIONS inches (millimeters)

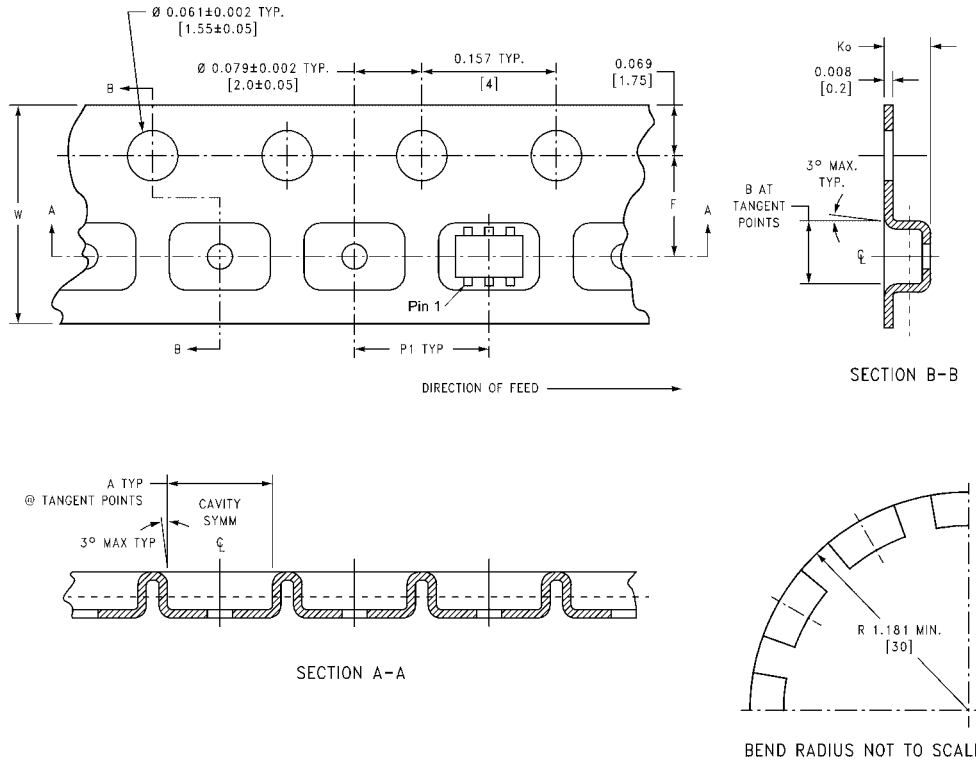

Package	Tape Size	DIM A	DIM B	DIM F	DIM K <sub>o</sub>	DIM P1	DIM W
SC70-6	8 mm	0.093 (2.35)	0.096 (2.45)	$0.138 \pm 0.004$ ( $3.5 \pm 0.10$ )	$0.053 \pm 0.004$ ( $1.35 \pm 0.10$ )	0.157 (4)	$0.315 \pm 0.004$ ( $8 \pm 0.1$ )

### Tape and Reel Specification (Continued)

#### TAPE FORMAT for MicroPak

Package Designator	Tape Section	Number Cavities	Cavity Status	Cover Tape Status
L6X	Leader (Start End)	125 (typ)	Empty	Sealed
	Carrier	5000	Filled	Sealed
	Trailer (Hub End)	75 (typ)	Empty	Sealed

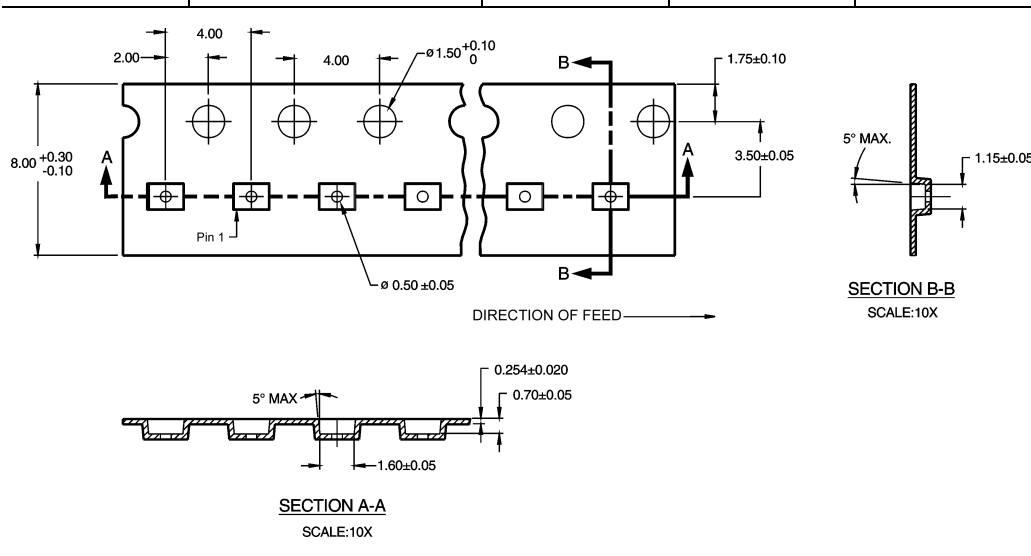

#### REEL DIMENSIONS inches (millimeters)

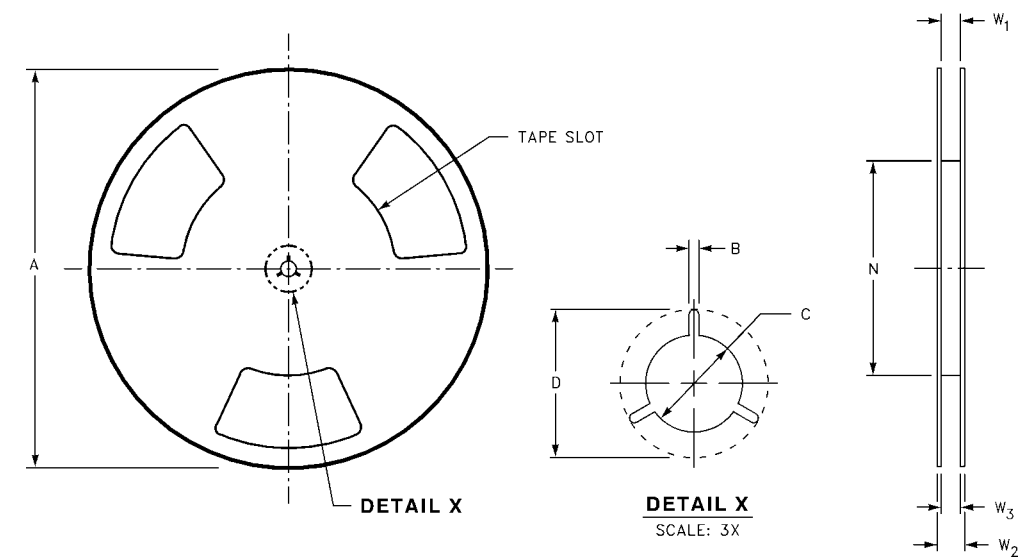

Tape Size	A	B	C	D	N	W1	W2	W3
8 mm	7.0 (177.8)	0.059 (1.50)	0.512 (13.00)	0.795 (20.20)	2.165 (55.00)	0.331 + 0.059/-0.000 (8.40 + 1.50/-0.00)	0.567 (14.40)	W1 + 0.078/-0.039 (W1 + 2.00/-1.00)

NC7SZ175

**Physical Dimensions** inches (millimeters) unless otherwise noted

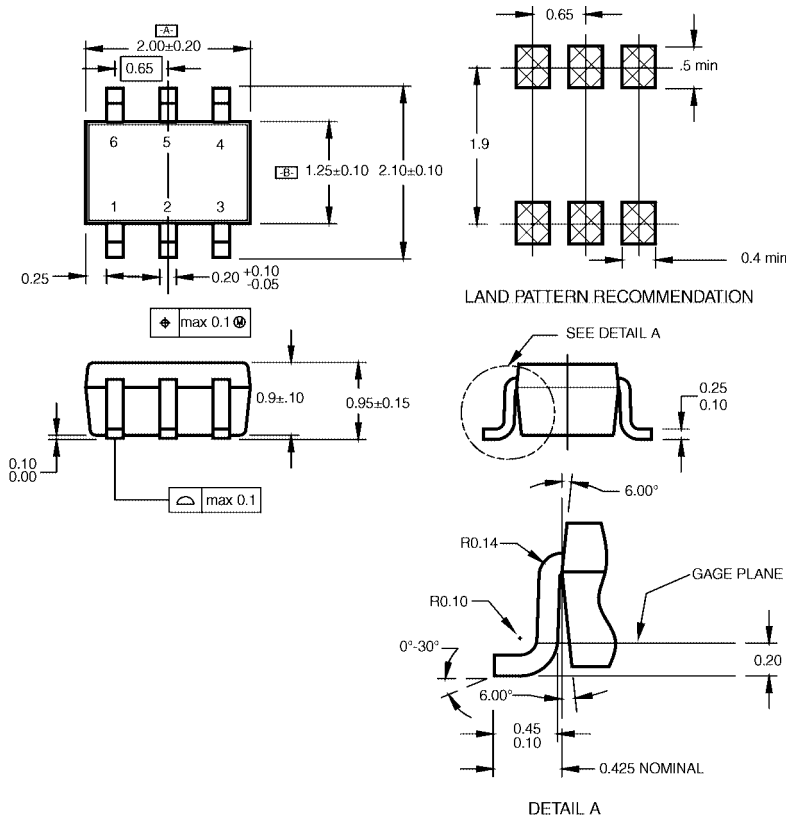

NOTES:

- A. CONFORMS TO EIAJ REGISTERED OUTLINE DRAWING SC88.
- B. DIMENSIONS DO NOT INCLUDE BURRS OR MOLD FLASH.
- C. DIMENSIONS ARE IN MILLIMETERS.

MAA06ARevC

**6-Lead SC70, EIAJ SC88, 1.25mm Wide  
Package Number MAA06A**



**Physical Dimensions** inches (millimeters) unless otherwise noted (Continued)

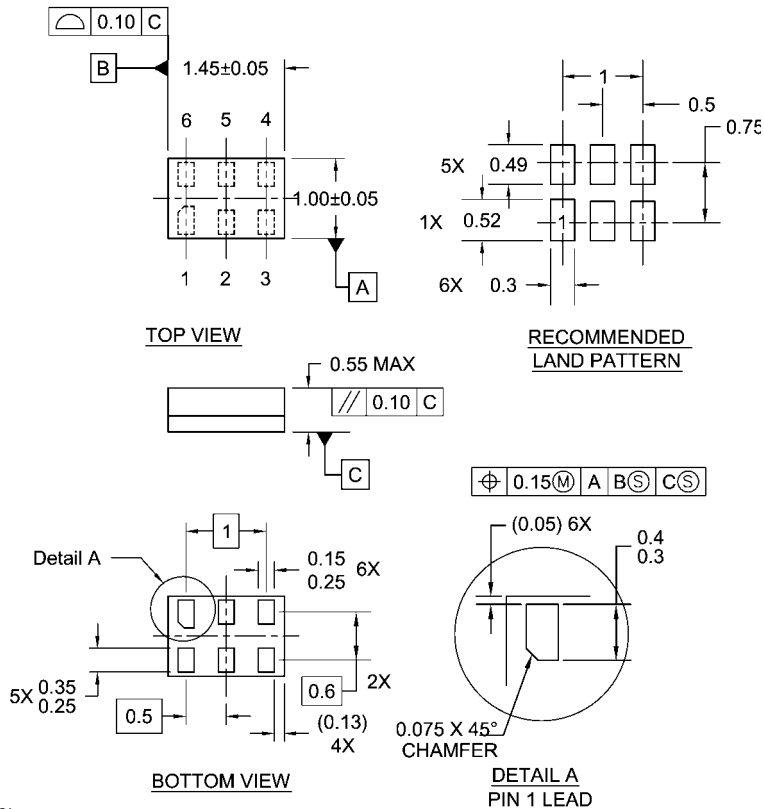

**Notes:**

1. JEDEC PACKAGE REGISTRATION IS ANTICIPATED
2. DIMENSIONS ARE IN MILLIMETERS
3. DRAWING CONFORMS TO ASME Y14.5M-1994

MAC06ARevB

**6-Lead MicroPak, 1.0mm Wide  
Package Number MAC06A**

Fairchild does not assume any responsibility for use of any circuitry described, no circuit patent licenses are implied and Fairchild reserves the right at any time without notice to change said circuitry and specifications.

**LIFE SUPPORT POLICY**

FAIRCHILD'S PRODUCTS ARE NOT AUTHORIZED FOR USE AS CRITICAL COMPONENTS IN LIFE SUPPORT DEVICES OR SYSTEMS WITHOUT THE EXPRESS WRITTEN APPROVAL OF THE PRESIDENT OF FAIRCHILD SEMICONDUCTOR CORPORATION. As used herein:

1. Life support devices or systems are devices or systems which, (a) are intended for surgical implant into the body, or (b) support or sustain life, and (c) whose failure to perform when properly used in accordance with instructions for use provided in the labeling, can be reasonably expected to result in a significant injury to the user.
2. A critical component in any component of a life support device or system whose failure to perform can be reasonably expected to cause the failure of the life support device or system, or to affect its safety or effectiveness.

[www.fairchildsemi.com](http://www.fairchildsemi.com)