

C&B motor

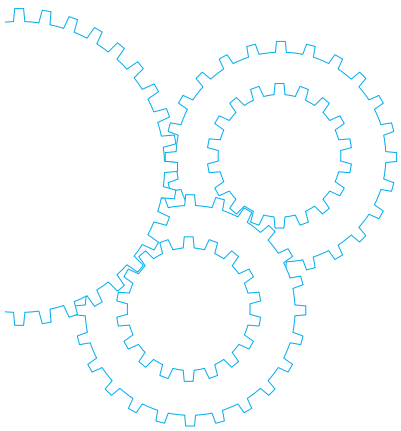

Contents	
• Motor Overview	B-342
• Model list	B-343
• Product information for each model	B-344

Outline of C&B motor

Features

- It is best fitted for high-frequency operation.
The high-accuracy and highly-responsive clutch and brake enables up to 100 cycles of start/stop per minute.
(For running in one direction only)
- High-reliability gear head used
It can withstand two million cycles of start/stop.
- Excitation-type clutch and brake
The clutch and brake of the C&B motor is of excitation type and operates on 24 VDC.

Construction

The clutch and brake are activated when the power is turned on because they are of excitation type. When the power is turned off, no coupling force of the clutch and no holding force of the brake is generated.

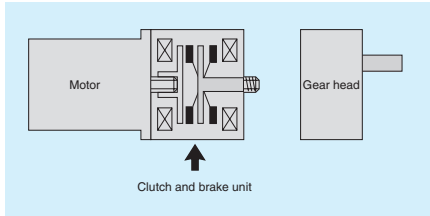

System configuration diagram

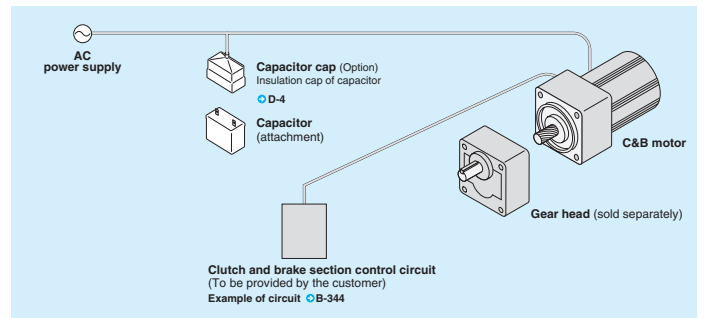

Coding system

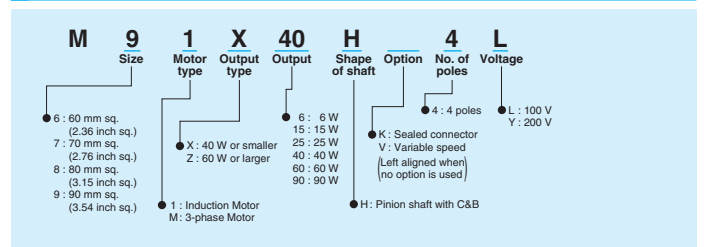

Fit tolerance

Fit tolerance symbol is used in the outside dimension diagram of motor and gear head. For further information, see "Fit tolerance" on page A-33.

Outline of C&B motor

Example of control circuit of C&B motor

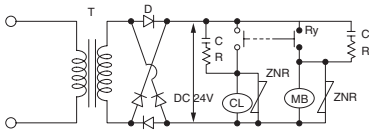

When contacts are used

- It is best that the capacity of the transformer should be more than 2 times the that of the C&B.
- The capacity of the diode should be more than 2.5 times the clutch current and the withstand voltage should be 400 V or more.
- Use the following part as a ZNR: ERZV10D101 (manufactured by Panasonic Electronic Device) or an equivalent.
- Use a CR between the contacts to protect them.

- C : 0.1 μ F, 250 V polyester etc.
 R : 47 Ω , 1/2 W
 T : Transformer
 D : Diode
 Ry : Relay
 ZNR: Surge absorber
 CL : Electromagnetic clutch
 MB : Electromagnetic brake

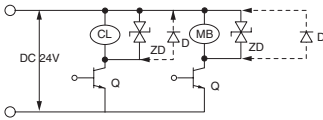

When no contacts are used

- The ZD or D should be in parallel with the CL and MB.
- Use VRD-type ZD047 manufactured by Ishizuka Electronics Corporation as a ZD.
- The withstand voltage of the transistor should be 100 V or more.
- When a diode is used, the release time will become longer.
- Do not energize the clutch and brake at a time.
 Particularly when a diode is used, note that the clutch or brake coil is energized even if the signal of the transistor is turned off.

- Q : Transistor
 ZD : VRD type
 D : Diode
 CL : Electromagnetic clutch
 MB : Electromagnetic brake

Connection of C&B motor and gear head

- Use the C&B motor together with the gear head.
- When connecting the gear head to the C&B motor, take care not to damage the C&B motor output shaft pinion.
- The following gear heads and mounting hardware cannot be used for the C&B motor.
 - Ball bearing gear head (MX6G□B (A), MX7G□B (A), MX8G□B, MX9G□B)
 - Metal bearing gear head (MX6G□M (A), MX7G□M (A), MX8G□M, MX9G□M)
 - Heavy-duty type gear head (MR9G□B, MP9G□B)
 - Orthogonal axis type gear head (MX9G□R, MZ9G□R)
 - Decimal gear head (MX6G10XB, MX7G10XB, MX8G10XB, MX9G10XB, MZ9G10XB)

C&B motor and MX□G□H type gear head

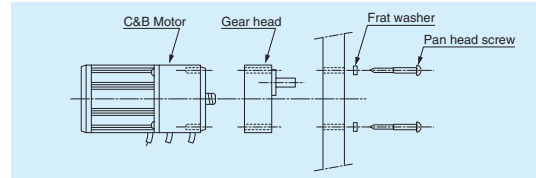

Mounting on equipment

Use the screws included with the gear head.
 No nuts are needed, when you use the accessory.
 The minimum board thickness should be such that the motor will not resonate.

Applicable board thickness (maximum)

MX6G	MX7G	MX8G	MX9G
8 mm (0.31 inch)	15 mm (0.59 inch)	15 mm (0.59 inch)	16 mm (0.63 inch)

C&B motor and MY9G□H type gear head

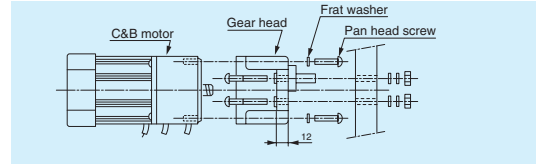

Connection of gear head

Use the screws included with the gear head.
 No nuts are needed, when you use the accessory.

Mounting on equipment

Use M8 screws. (to be supplied by customer.)
 Determine the screw length in consideration of the thickness (12 mm) of the mounting flange of the gear head.

Outline of C&B motor

Permissible load torque and permissible inertia moment

- The load used should fall within the portion under the curve in the following selection diagrams.
- The curve in the output selection diagram represents the load torque and inertia load for withstanding two million cycles of start/stop.
- Note that the torque is reduced when the variable speed motor is run at a low speed. For further details, refer to the separate catalog of the variable speed motor.
- When the motor is to be run at a speed of lower than 30 min⁻¹, select output using the selection diagram for 30 min⁻¹.

Output selection diagram

• 500min⁻¹ 1/3 50Hz
1/3.6 60Hz

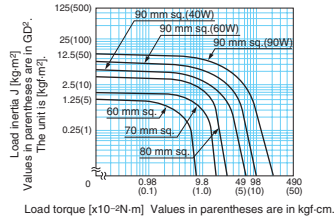

• 200min⁻¹ 1/7.5 50Hz
1/9 60Hz

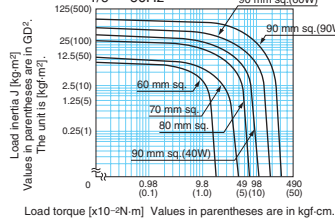

• 150min⁻¹ 1/10 50Hz

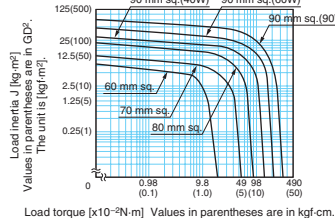

• 300min⁻¹ 1/5 50Hz
1/6 60Hz

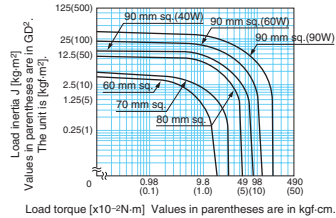

• 180min⁻¹ 1/10 60Hz

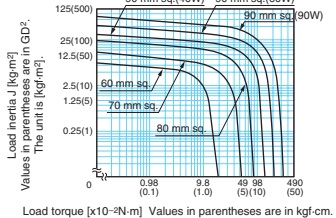

• 120min⁻¹ 1/12.5 50Hz
1/15 60Hz

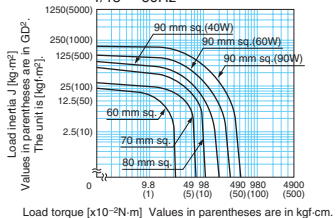

• 100min⁻¹ 1/15 50Hz
1/18 60Hz

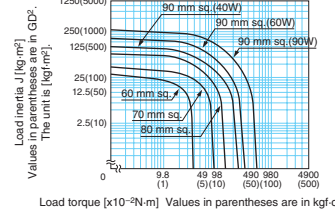

• 75min⁻¹ 1/20 50Hz

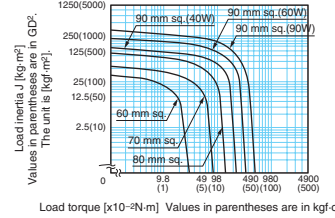

• 50min⁻¹ 1/30 50Hz
1/36 60Hz

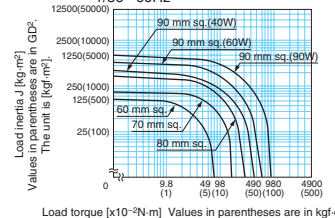

• 90min⁻¹ 1/20 60Hz

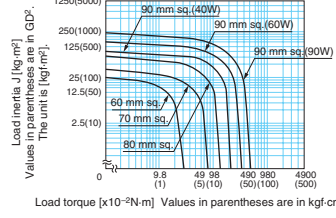

• 60min⁻¹ 1/25 50Hz
1/30 60Hz

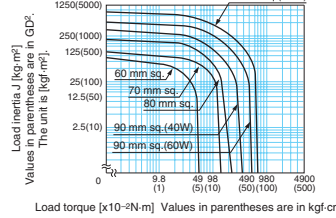

• 30min⁻¹ 1/50 50Hz
1/60 60Hz

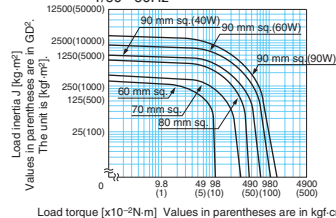

• 60 mm sq.: 2.36 inch
70 mm sq.: 2.76 inch
80 mm sq.: 3.15 inch
90 mm sq.: 3.54 inch

Outline of C&B motor

Gear head

Gear heads exclusively used for C&B motor are designed to withstand frequent start and stop duty cycles. While referring to the model list, select a gear suitable for the motor.

• Gear head for C&B motor

(MX6G□H, MX7G□H, MX8G□H, MX9G□H, MY9G□H)

The following gear heads cannot be used for the C&B motor.

• Metal bearing gear head

(MX6G□M, MX7G□M, MX8G□M, MX9G□M)

• Heavy-duty type gear head

(MR9G□R, MP9G□R)

• Orthogonal axis type gear head

(MX9G□R, MZ9G□R)

• Decimal gear head

(MX6G10XB, MX7G10XB, MX8G10XB, MX9G10XB, MZ9G10XB)

<Bearing>

The bearing is of the ball bearing type that has durability against fluctuating load and impact load.

<Reduction Ratio>

22 reduction ratios from 1/3 to 1/180 are available (23 reduction ratios from 1/3 to 1/200 for MZ(Y)9GoB). Select a reduction ratio suitable for the output speed of the motor and the speed of the machine used together with the motor.

Maximum permissible torque

There is a limit to the strength of a gear due to its material and construction. The usable load torque determined based on this limit is called permissible torque. As can be seen from the above-mentioned formula, the load becomes larger when the reduction ratio is increased. If the gear head is used with the load exceeding the permissible torque, its life expectancy will be shortened significantly. Refer to the following graph and the permissible torque for each model and use the gear head at an appropriate load.

• Maximum permissible torque

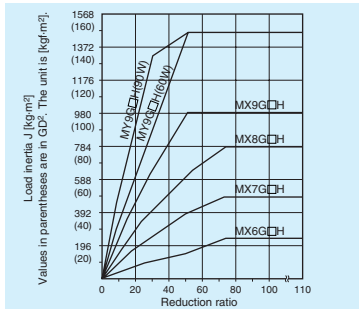

Gear head efficiency

Model No.	Reduction ratio																					
	3	3.6	5	6	7.5	9	10	12.5	15	18	20	25	30	36	50	60	75	90	100	120	150	180
MX6G□H MX7G□H MX8G□H MX9G□H	81%									75%						70%				—		
MZ9G□H	81%			75%			70%			65%						65%						

Calculation of torque at output shaft of gear head

$$N_G = \frac{N_M}{i}$$

N_G : Speed of gear head (min^{-1})
 N_M : Motor speed (min^{-1})
 i : Reduction ratio of gear head
 $T_G = T_M \times i \times \eta$
 T_G : Output torque of gear head (N·m)
 T_M : Motor torque (N·m)
 η : Gear head efficiency

Service factor

Life expectancy of motor varies depending on load fluctuation. To determine the life expectancy, a factor called service factor, as shown in the table below is used. First choose the appropriate service factor according to the type of load and multiply the result by the required power to determine the design power.

• Service factor

Type of load	Typical load	Service factor		
		5 hours/day	8 hours/day	24 hours/day
Constant	Belt conveyor, One-directional rotation	0.8	1.0	1.5
	Start/Stop, Cam-drive	1.2	1.5	2.0
Medium-impact	Instant FWD/REV, Instant stop	1.5	2.0	2.5
Heavy-impact	Frequent medium-impact	2.5	3.0	3.5

The required allowable shaft torque T_A of the gear head can be determined based on the service factor and actual load torque T_1 :

$$T_A = T_1 \times S_f$$

T_A : Allowable torque of gear head (N·m)
 T_1 : Actual load torque (N·m)
 S_f : Service factor

Use the motor so that the allowable torque T_A calculated from the formula above falls within the allowable torque range. * Though it seems that the motor can be operated even in overload when the service factor is 0.8, note that the service factor is defined for the allowable torque of the gear head. If the motor is operated in overload, the life of insulator may be shortened or the motor may be burned out due to an abnormal temperature rise.

Standard life expectancy

Standard life expectancy: Standard life expectancy when operated for 8 hours/day at the standard load (Service factor=1.0)

* The oil seal is excluded because it is a consumable.

• Calculation of life expectancy

Calculate the life expectancy while referring to the service factor table shown above.

When the service factor is 2.0, for example, the life expectancy is calculated as follows:

$$\text{Life expectancy} = 5,000 \text{ (h)} / 2.0 = 2,500 \text{ (h)}$$

• Standard life expectancy

Gear head for C&B motor	Life (hours)
	5,000 hours

Outline of C&B motor

Pinion shaft motor

Applicable gear head

• Single-phase / 4 poles

Size	Output (W)	Leadwire type			Sealed connector type		
		Model number	Specifications	Page	Model number	Specifications	Page
60 mm sq (2.36 inch sq)	6	M61X6H4L	100V	B-352			
		M61X6H4Y	200V	B-352			
70 mm sq (2.76 inch sq)	15	M71X15H4L	100V	B-354			
		M71X15H4Y	200V	B-354			
80 mm sq (3.15 inch sq)	25	M81X25H4L	100V	B-356	M81X25HK4L	100V	B-364
		M81X25H4Y	200V	B-356	M81X25HK4Y	200V	B-364
90 mm sq (3.54 inch sq)	40	M91X40H4L	100V	B-358	M91X40HK4L	100V	B-366
		M91X40H4Y	200V	B-358	M91X40HK4Y	200V	B-366
	60	M91Z60H4L	100V	B-360	M91Z60HK4L	100V	B-368
		M91Z60H4Y	200V	B-360	M91Z60HK4Y	200V	B-368
	90	M91Z90H4L	100V	B-362	M91Z90HK4L	100V	B-370
		M91Z90H4Y	200V	B-362	M91Z90HK4Y	200V	B-370

Variable speed induction motor (leadwire)			
Model number	Specifications	Page	
M61X6HV4L	100V	B-388	
M61X6HV4Y	200V	B-388	
M71X15HV4L	100V	B-390	
M71X15HV4Y	200V	B-390	
M81X25HV4L	100V	B-392	
M81X25HV4Y	200V	B-392	
M91X40HV4L	100V	B-394	
M91X40HV4Y	200V	B-394	
M91Z60HV4L	100V	B-396	
M91Z60HV4Y	200V	B-396	
M91Z90HV4L	100V	B-398	
M91Z90HV4Y	200V	B-398	

Standard gear head (for C&B)	
Ball bearing	
	MX6G□H
	MX7G□H
	MX8G□H
	MX9G□H
	MY9G□H

• 3-phase / 2poles

Size	Output (W)	Leadwire type			Sealed connector type		
		Model number	Specifications	Page	Model number	Specifications	Page
80 mm sq (3.15 inch sq)	25						
90 mm sq (3.54 inch sq)	40	M8MX25H4Y	200V	B-372	M8MX25HK4Y	200V	B-380
		M9MX40H4Y	200V	B-374	M9MX40HK4Y	200V	B-382
	60	M9MZ60H4Y	200V	B-376	M9MZ60HK4Y	200V	B-384
		90	M9MZ90H4Y	200V	B-378	M9MZ90HK4Y	200V

Standard gear head (for C&B)	
Ball bearing	
	MX8G□H
	MX9G□H
	MY9G□H

• Possible combination of speed controller and motor

	Size	Output (W)	Motor		Voltage (V)	Speed controller			
			Certified	Part No.		MGSD type	EX type	SD48 type	EX48 type
C&B motor / Variable speed induction motor	60 mm sq (2.36 inch sq)	6	-----	M61X6HV4L	100	MGSDA1	DV1131	DVSD48AL	DVEX48AL
			-----	M61X6HV4Y	200	MGSDB2	DV1231	DVSD48AY	DVEX48AY
	70 mm sq (2.76 inch sq)	15	-----	M71X15HV4L	100	MGSDA1	DV1132	DVSD48AL	DVEX48AL
			-----	M71X15HV4Y	200	MGSDB2	DV1231	DVSD48AY	DVEX48AY
	80 mm sq (3.15 inch sq)	25	-----	M81X25HV4L	100	MGSDA1	DV1132	DVSD48BL	DVEX48BL
			-----	M81X25HV4Y	200	MGSDB2	DV1234	DVSD48BY	DVEX48BY
	90 mm sq (3.54 inch sq)	40	-----	M91X40HV4L	100	MGSDA1	DV1132	DVSD48BL	DVEX48BL
			-----	M91X40HV4Y	200	MGSDB2	DV1234	DVSD48BY	DVEX48BY
	60	-----	-----	M91Z60HV4L	100	MGSDB1	DV1134	DVSD48CL	DVEX48CL
			-----	M91Z60HV4Y	200	MGSDB2	DV1234	DVSD48CY	DVEX48CY
	90	-----	-----	M91Z90HV4L	100	MGSDB1	DV1134	DVSD48CL	DVEX48CL
			-----	M91Z90HV4Y	200	MGSDB2	DV1234	DVSD48CY	DVEX48CY

C&B motor (induction motor leadwire)

60 mm (2.36 inch) sq. 6 W

Specifications

Size	Motor model No.	Number of pole (P)	Output (W)	Voltage (V)	Frequency (Hz)	Rating (min)	Motor characteristics					Starting current (A)	Starting torque N-m (oz-in)	Capacitor (μF) (rated voltage)
							Input (W)	Current (A)	Speed (min ⁻¹)	Torque N-m (oz-in)				
60 mm sq.	M61X6H4L	4	6	100	50	Cont.	20	0.21	1250	0.048(6.8)	0.30	0.049 (6.94)	2.5 (200V)	
							20	0.20	1575	0.038(5.38)				
	M61X6H4Y	4	6	200	50	Cont.	20	0.11	1250	0.048(6.8)	0.15	0.049 (6.94)	0.7 (400V)	
							20	0.10	1600	0.037(5.23)				

Size	Motor model No.	Clutch/Brake	Static friction torque N-m (oz-in)	Rating Voltage (DC-V)	Capacity W About 75°C	Response time		
						Armature absorbing time (ms)	Armature release time (ms)	Actual torque start time (ms)
60 mm sq.	M61X6H4L	Clutch	0.294 (41.6)	24	4	15	25	20
		Brake						
	M61X6H4Y	Clutch						
		Brake						

(Make selection while referring to the output selection diagrams for C&B motor shown on pages B-346 to 347.)

Reduction ratio	Speed (min ⁻¹)																									
	3	3.6	5	6	7.5	9	10	12.5	15	18	20	25	30	36	50	60	75	90	100	120	150	180				
50Hz	500	416.7	300	250	200	166.7	150	120	100	83.3	75	60	50	41.7	30	25	20	16.7	15	12.5	10	8.3				
60Hz	600	500	360	300	240	200	180	144	120	100	90	72	60	50	36	30	24	20	18	15	12	10				
Applicable gear head	MX6G3H to MX6G180H (ball bearing)											Same as motor rotational direction					Reverse to motor rotational direction					Same as motor rotational direction				

Connection diagram

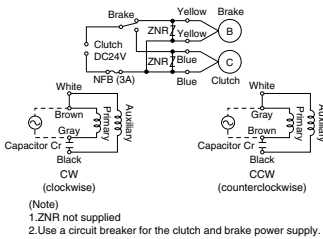

* Please read your User's manual carefully so that you will understand the operation and safety precautions before attempting to operate the system.

Motor (dimensions)

M61X6H4L 4P 6W 100V
M61X6H4Y 4P 6W 200V

Scale: 1/3, Unit: mm (inch)

Mass 1.2 kg 2.71 lb
Helical gear 0.5
Module 0.5
Number of teeth 10

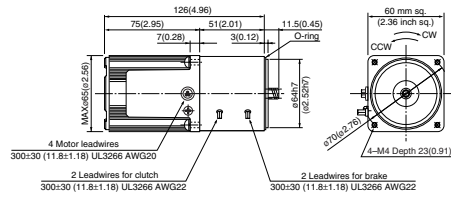

Capacitor (dimensions) [attachment]

Unit: mm (inch)

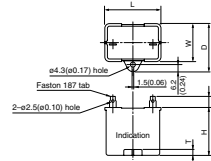

Capacitor dimension list

Unit: upper (mm) / lower (inch)

Model number of motor	Model number of capacitor (attachment)	L	W	D	H	T	Capacitor cap (option)
M61X6H4L	M0PC2.5M20	39.5 (1.56)	16 (0.63)	26.5 (1.04)	30.5 (1.20)	4 (0.16)	M0PC3917
M61X6H4Y	M0PC0.7M40	39.5 (1.56)	16.5 (0.64)	27 (1.06)	27 (1.06)	4 (0.16)	M0PC3917

Gear head (dimensions)

Scale: 1/3, Unit: mm (inch)

MX6G□H (ball bearing) Mass 0.34 kg (0.75 lb): Output shaft D cut

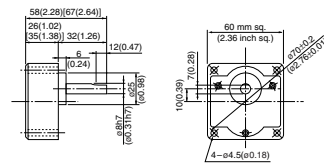

* Figures in [] represent the dimensions of MX6G□H (1/30 or larger reduction ratio).

(Note) Because the dimensions may be subject to change, also check the determinate dimensions if the gear head is to be used for design.

Gear head combination B-400 Controls C-4 Option D-2

Induction motor
Reversible motor
3-phase motor
Electromagnetic brake motor
Variable speed induction motor
Variable speed reversible motor
Variable speed synchronous motor
Variable speed unit motor
C&B motor
2-pole round shaft motor
Gear head
Gear head -high (U.S.A.)

C&B motor (induction motor leadwire)

70 mm (2.76 inch) sq. 15 W

Specifications

Size	Motor model No.	Number of pole (P)	Output (W)	Voltage (V)	Frequency (Hz)	Rating (min)	Motor characteristics						
							Rating			Starting current (A)	Starting torque N-m (oz-in)	Capacitor (µF) (rated voltage)	
							Input (W)	Current (A)	Speed (min ⁻¹)				Torque N-m (oz-in)
70 mm sq.	M71X15H4L	4	15	100	50	Cont.	34	0.37	1250	0.11(15.6)	0.61	0.077(10.9)	4
					60		33	0.33	1575	0.088(12.5)	0.57	0.077(10.9)	(200V)
	200			50	33	0.18	1300	0.11(15.6)	0.30	0.077(10.9)	1		
				60	34	0.18	1600	0.088(12.5)	0.29	0.077(10.9)	(400V)		

Size	Motor model No.	Clutch	Clutch and brake characteristics					
			Static friction torque N-m (oz-in)	Rating Voltage (DC-V)	Capacity W About 75°C	Response time		
				Armature absorbing time (ms)	Armature release time (ms)	Actual torque start time (ms)		
70 mm sq.	M71X15H4L	Clutch	0.294 (41.6)	24	15	25	20	
		Brake						4
	M71X15H4Y	Clutch						2
		Brake						4

(Make selection while referring to the output selection diagrams for C&B motor shown on pages B-346 to 347.)

Reduction ratio	Speed (min ⁻¹)																									
	3	3.6	5	6	7.5	9	10	12.5	15	18	20	25	30	36	50	60	75	90	100	120	150	180				
50Hz	500	416.7	300	250	200	166.7	150	120	100	83.3	75	60	50	41.7	30	25	20	16.7	15	12.5	10	8.3				
60Hz	600	500	360	300	240	200	180	144	120	100	90	72	60	50	36	30	24	20	18	15	12	10				
Applicable gear head	MX7G3H to MX7G180H (ball bearing)											Same as motor rotational direction					Reverse to motor rotational direction					Same as motor rotational direction				

Connection diagram

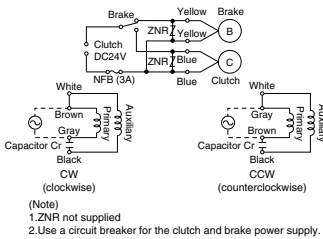

* Please read your User's manual carefully so that you will understand the operation and safety precautions before attempting to operate the system.

Motor (dimensions)

M71X15H4L 4P 15W 100V
 M71X15H4Y 4P 15W 200V

Scale: 1/3, Unit: mm (inch)

Mass 1.7 kg 3.79 lb
 Helical gear 0.5
 Module 10
 Number of teeth 10

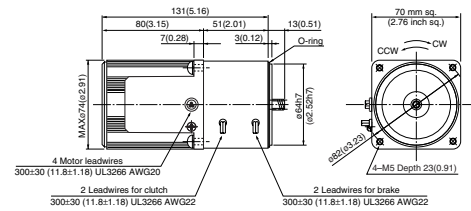

Capacitor (dimensions) [attachment]

Unit: mm (inch)

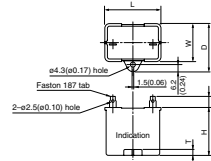

Capacitor dimension list

Unit: upper (mm) / lower (inch)

Model number of motor	Model number of capacitor (attachment)	L	W	D	H	T	Capacitor cap (option)
M71X15H4L	M0PC4M20	39.5 (1.56)	16 (0.63)	26.5 (1.04)	30.5 (1.20)	4 (0.16)	M0PC3917
M71X15H4Y	M0PC1M40	39.5 (1.56)	16.5 (0.64)	27 (1.06)	27 (1.06)	4 (0.16)	M0PC3917

Gear head (dimensions)

Scale: 1/3, Unit: mm (inch)

MX7G□□ (ball bearing) Mass 0.54 kg (1.19 lb)

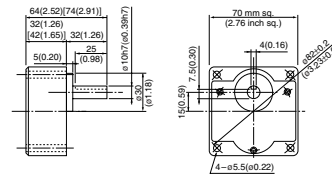

Key and keyway (dimensions) [attachment]

MX7G□□

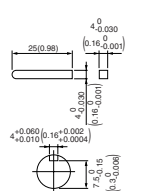

* Figures in [] represent the dimensions of MX7G□□ (1/30 or larger reduction ratio).

(Note) Because the dimensions may be subject to change, also check the determinate dimensions if the gear head is to be used for design.

Gear head combination B-400 Controls C-4 Option D-2

B-355

Induction motor
 Reversible motor
 3-phase motor
 Electromagnetic brake motor
 Variable speed induction motor
 Variable speed reversible motor
 Variable speed synchronous motor
 Variable speed unit motor
 C&B motor
 2-pole round shaft
 Gear head
 Gear head -high (U.S.A.)

C&B motor (induction motor leadwire)

80 mm (3.15 inch) sq. 25 W

Specifications

Size	Motor model No.	Number of pole (P)	Output (W)	Voltage (V)	Frequency (Hz)	Rating (min)	Motor characteristics					Starting current (A)	Starting torque N-m (oz-in)	Capacitor (μF) (rated voltage)
							Input (W)	Current (A)	Speed (min ⁻¹)	Torque N-m (oz-in)	Efficiency			
80 mm sq.	M81X25H4L	4	25	100	50	Cont.	51	0.55	1250	0.19(26.9)	0.98	0.16 (22.66)	6 (200V)	
							49	0.48	1550	0.15(21.24)	0.94			
	M81X25H4Y	200	50	60	51	0.27	1250	0.19(26.9)	0.50					
					49	0.24	1575	0.15(21.24)	0.47					

Size	Motor model No.	Clutch / Brake	Static friction torque N-m (oz-in)	Rating Voltage (DC-V)	Capacity W About 75°C	Response time		
						Armature absorbing time (ms)	Armature release time (ms)	Actual torque start time (ms)
80 mm sq.	M81X25H4L	Clutch	0.980 (139)	24	7	15	25	20
		Brake						
	M81X25H4Y	Clutch						
		Brake						

(Make selection while referring to the output selection diagrams for C&B motor shown on pages B-346 to 347.)

Reduction ratio	Speed (min ⁻¹)																										
	3	3.6	5	6	7.5	9	10	12.5	15	18	20	25	30	36	50	60	75	90	100	120	150	180					
50Hz	500	416.7	300	250	200	166.7	150	120	100	83.3	75	60	50	41.7	30	25	20	16.7	15	12.5	10	8.3					
60Hz	600	500	360	300	240	200	180	144	120	100	90	72	60	50	36	30	24	20	18	15	12	10					
Applicable gear head	MX8G3H to MX8G180H (ball bearing)										Same as motor rotational direction					Reverse to motor rotational direction							Same as motor rotational direction				

Connection diagram

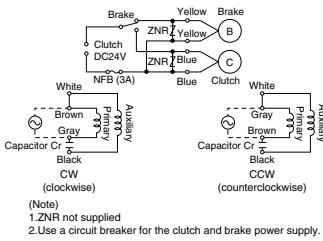

* Please read your User's manual carefully so that you will understand the operation and safety precautions before attempting to operate the system.

Motor (dimensions)

M81X25H4L 4P 25W 100V
M81X25H4Y 4P 25W 200V

Scale: 1/3, Unit: mm (inch)

Mass 2.5 kg 5.80 lb
Helical gear 0.6
Module 11
Number of teeth 11

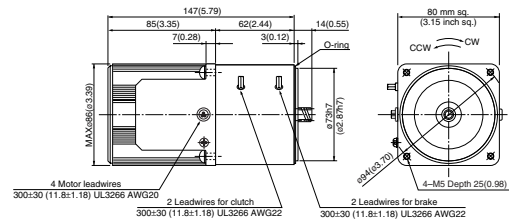

Capacitor (dimensions) [attachment]

Unit: mm (inch)

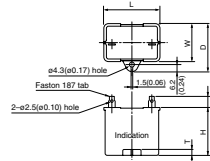

Capacitor dimension list

Unit: upper (mm) / lower (inch)

Model number of motor	Model number of capacitor (attachment)	L	W	D	H	T	Capacitor cap (option)
M81X25H4L	M0PC6M20	39.5 (1.56)	17.5 (0.69)	28 (1.10)	30.5 (1.20)	4 (0.16)	M0PC3917
M81X25H4Y	M0PC1.5M40	39.5 (1.56)	22 (0.87)	30.5 (1.20)	32.5 (1.28)	4 (0.16)	M0PC3922

Gear head (dimensions)

Scale: 1/3, Unit: mm (inch)

MX8G□H (ball bearing) Mass 0.68 kg (1.50 lb)

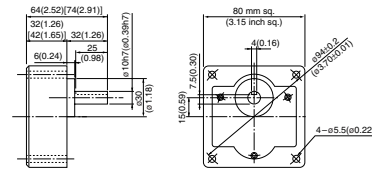

Key and keyway (dimensions) [attachment]

MX8G□H

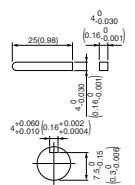

* Figures in [] represent the dimensions of MX8G□H (1/30 or larger reduction ratio).

(Note) Because the dimensions may be subject to change, also check the determinate dimensions if the gear head is to be used for design.

Gear head combination B-400 Controls C-4 Option D-2

B-357

Induction motor
Reversible motor
3-phase motor
Electromagnetic brake motor
Variable speed induction motor
Variable speed reversible motor
Variable speed synchronous motor
Variable speed unit motor
C&B motor
2-pole round shaft
Gear head
Gear head -high (U.S.A.)

C&B motor (induction motor leadwire)

90 mm (3.54 inch) sq. 40 W

Specifications

Size	Motor model No.	Number of pole (P)	Output (W)	Voltage (V)	Frequency (Hz)	Rating (min)	Motor characteristics						
							Input (W)	Current (A)	Speed (min ⁻¹)	Torque N-m (oz-in)	Starting current (A)	Starting torque N-m (oz-in)	Capacitor (μF) (rated voltage)
90 mm sq.	M91X40H4L	4	40	100	50	Cont.	78	0.89	1225	0.30(42.5)	1.5	0.24(34.0)	10 (200V)
							72	0.72	1550	0.25(35.4)	1.5	0.25(35.4)	
	M91X40H4Y	4	40	200	50	Cont.	79	0.43	1250	0.30(42.5)	0.83	0.25(35.4)	2.5 (400V)
							72	0.36	1575	0.24(34.0)	0.76	0.25(35.4)	

Size	Motor model No.	Clutch/Brake	Static friction torque N-m (oz-in)	Rating Voltage (DC-V)	Capacity W About 75°C	Response time		
						Armature absorbing time (ms)	Armature release time (ms)	Actual torque start time (ms)
90 mm sq.	M91X40H4L	Clutch	1.47 (208.17)	24	7	15	25	20
		Brake			5			
	M91X40H4Y	Clutch			7			
		Brake			5			

(Make selection while referring to the output selection diagrams for C&B motor shown on pages B-346 to 347.)

Reduction ratio	Speed (min ⁻¹)																									
	3	3.6	5	6	7.5	9	10	12.5	15	18	20	25	30	36	50	60	75	90	100	120	150	180				
50Hz	500	416.7	300	250	200	166.7	150	120	100	83.3	75	60	50	41.7	30	25	20	16.7	15	12.5	10	8.3				
60Hz	600	500	360	300	240	200	180	144	120	100	90	72	60	50	36	30	24	20	18	15	12	10				
Applicable gear head	MX9G3H to MX9G180H (ball bearing)											Same as motor rotational direction					Reverse to motor rotational direction					Same as motor rotational direction				

Connection diagram

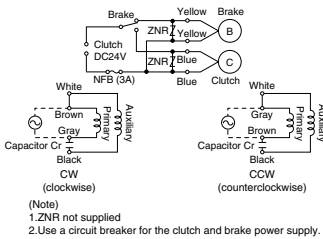

* Please read your User's manual carefully so that you will understand the operation and safety precautions before attempting to operate the system.

Motor (dimensions)

Scale: 1/3, Unit: mm (inch)

M91X40H4L 4P 40W 100V
M91X40H4Y 4P 40W 200V

Mass 3.6 kg 7.98 lb
Helical gear 0.6
Module 11
Number of teeth 11

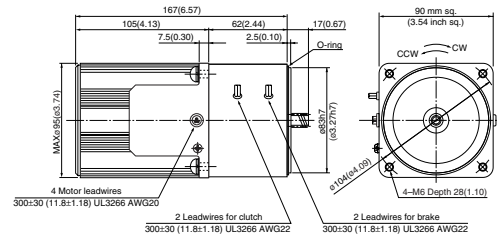

Capacitor (dimensions) [attachment]

Unit: mm (inch)

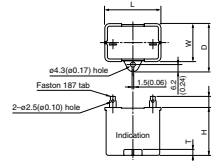

Capacitor dimension list

Unit: upper (mm) / lower (inch)

Model number of motor	Model number of capacitor (attachment)	L	W	D	H	T	Capacitor cap (option)
M91X40H4L	M0PC10M20	39.5 (1.56)	26.7 (1.05)	37 (1.46)	32 (1.26)	4 (0.16)	M0PC3926
M91X40H4Y	M0PC2.5M40	43.7 (1.72)	24 (0.94)	34.5 (1.36)	34.5 (1.36)	4 (0.16)	M0PC5026

Gear head (dimensions)

Scale: 1/3, Unit: mm (inch)

MX9G□H (ball bearing) Mass 1.2 kg (2.65 lb)

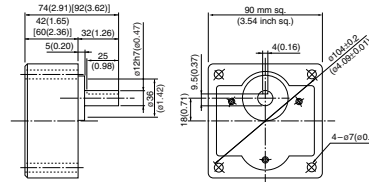

Key and keyway (dimensions) [attachment]

MX9G□H

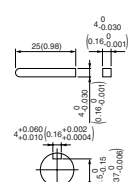

* Figures in [] represent the dimensions of MX9G□H (1/20 or larger reduction ratio).

(Note) Because the dimensions may be subject to change, also check the determinate dimensions if the gear head is to be used for design.

Gear head combination B-400 Controls C-4 Option D-2

B-359

Induction motor
Reversible motor
3-phase motor
Electromagnetic brake motor
Variable speed induction motor
Variable speed reversible motor
Variable speed synchronous motor
Variable speed unit motor
C&B motor
2-pole round shaft
Gear head
Gear head -high (U.S.A.)

C&B motor (induction motor leadwire)

90 mm (3.54 inch) sq. 90 W

Specifications

Size	Motor model No.	Number of pole (P)	Output (W)	Voltage (V)	Frequency (Hz)	Rating (min)	Motor characteristics						
							Rating				Starting current (A)	Starting torque N-m (oz-in)	Capacitor (μF) (rated voltage)
							Input (W)	Current (A)	Speed (min ⁻¹)	Torque N-m (oz-in)			
90 mm sq.	M91Z90H4L	4	90	100	50	Cont.	153	1.6	1325	0.65(92.0)	3.3	25 (200V)	
							160	1.6	1625	0.53(75.1)	3.0		
	M91Z90H4Y	4	90	200	50	Cont.	150	0.75	1325	0.62(87.8)	1.7	5.8 (400V)	
							160	0.80	1650	0.51(72.2)	1.5		

Size	Motor model No.	Clutch / Brake	Static friction torque N-m (oz-in)	Rating Voltage (DC-V)	Capacity W About (75°C)	Response time		
						Armature absorbing time (ms)	Armature release time (ms)	Actual torque start time (ms)
90 mm sq.	M91Z90H4L	Clutch	1.47 (208)	24	7	15	25	20
		Brake						
	M91Z90H4Y	Clutch						
		Brake						

(Make selection while referring to the output selection diagrams for C&B motor shown on pages B-346 to 347.)

Reduction ratio	Speed (min ⁻¹)																						
	3	3.6	5	6	7.5	9	10	12.5	15	18	20	25	30	36	50	60	75	90	100	120	150	180	200
50Hz	500	416.7	300	250	200	186.7	150	120	100	83.3	75	60	50	41.7	30	25	20	16.7	15	12.5	10	8.3	7.5
60Hz	600	500	360	300	240	200	180	144	120	100	90	72	60	50	36	30	24	20	18	15	12	10	9
Applicable gear head	MY9G3H to MY9G200H (ball bearing)		Rotational direction		Same as motor rotational direction		Reverse to motor rotational direction		Same as motor rotational direction						Reverse to motor rotational direction								

Connection diagram

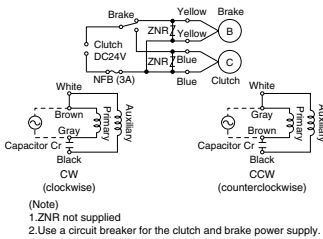

* Please read your User's manual carefully so that you will understand the operation and safety precautions before attempting to operate the system.

Motor (dimensions)

Scale: 1/3, Unit: mm (inch)

M91Z90H4L 4P 90W 100V
M91Z90H4Y 4P 90W 200V

Mass 4.1 kg 9.11 lb
Helical gear 0.8
Module 11
Number of teeth 11

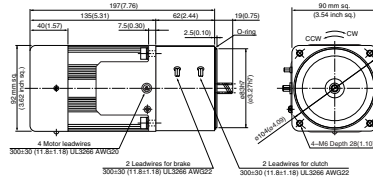

Capacitor (dimensions) [attachment]

Unit: mm (inch)

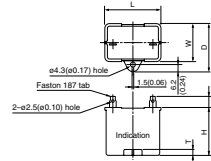

Capacitor dimension list Unit: upper (mm) / lower (inch)

Model number of motor	Model number of capacitor (attachment)	L	W	D	H	T	Capacitor cap (option)
M91Z90H4L	M0PC25M20	50.2 (1.98)	31 (1.22)	41 (1.61)	42 (1.65)	5 (0.20)	M0PC5032
M91Z90H4Y	M0PC5.8M40	50 (1.97)	30.5 (1.20)	41 (1.61)	41.5 (1.63)	4 (0.16)	M0PC5032

Gear head (dimensions)

Scale: 1/4, Unit: mm (inch)

MY9G□H (ball bearing) Mass 1.5 kg (3.31 lb)

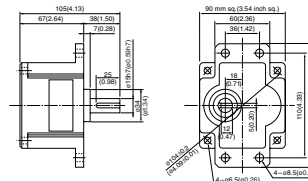

Key and keyway (dimensions) [attachment]

MY9G□M

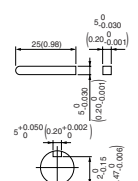

(Note) Because the dimensions may be subject to change, also check the determinate dimensions if the gear head is to be used for design.

Gear head combination B-400 Controls C-4 Option D-2

B-363

Induction motor
Reversible motor
3-phase motor
Electromagnetic brake motor
Variable speed induction motor
Variable speed reversible motor
Variable speed synchronous motor
Variable speed unit motor
C&B motor
2-pole round shaft motor
Gear head
Gear head -high (U.S.A.)

C&B motor (induction motor sealed connector)

80 mm (3.15 inch) sq. 25 W

Specifications

Size	Motor model No.	Number of pole (P)	Output (W)	Voltage (V)	Frequency (Hz)	Rating (min)	Motor characteristics						Starting current (A)	Starting torque N-m (oz-in)	Capacitor (µF) (rated voltage)
							Input (W)	Current (A)	Speed (min ⁻¹)	Torque N-m (oz-in)	Efficiency (%)	Power factor			
80 mm sq.	M81X25HK4L	4	25	100	50	Cont.	51	0.55	1250	0.19(26.9)	0.98	0.16 (22.7)	6 (200V)		
							49	0.48	1550	0.15(21.2)	0.94				
	M81X25HK4Y	200	50	60	51	0.27	1250	0.19(26.9)	0.50						
					49	0.24	1575	0.15(21.2)	0.47						

Size	Motor model No.	Clutch / Brake	Static friction torque N-m (oz-in)	Rating Voltage (DC-V)	Capacity W About 75°C	Response time		
						Armature absorbing time (ms)	Armature release time (ms)	Actual torque start time (ms)
80 mm sq.	M81X25HK4L	Clutch	0.980 (139)	24	7	15	25	20
		Brake						
	M81X25HK4Y	Clutch						
		Brake						

(Make selection while referring to the output selection diagrams for C&B motor shown on pages B-346 to 347.)

Reduction ratio	3 3.6 5 6 7.5 9 10 12.5 15 18 20 25 30 36 50 60 75 90 100 120 150 180																						
	50Hz	500	416.7	300	250	200	166.7	150	120	100	83.3	75	60	50	41.7	30	25	20	16.7	15	12.5	10	8.3
60Hz	600	500	360	300	240	200	180	144	120	100	90	72	60	50	36	30	24	20	18	15	12	10	
Applicable gear head	MX8G3H to MX8G180H (ball bearing)	Same as motor rotational direction											Reverse to motor rotational direction					Same as motor rotational direction					

Connection diagram

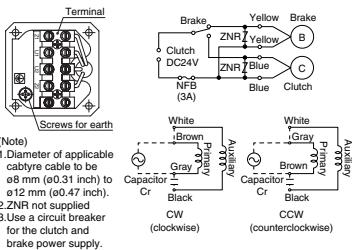

* Please read your User's manual carefully so that you will understand the operation and safety precautions before attempting to operate the system.

Motor (dimensions)

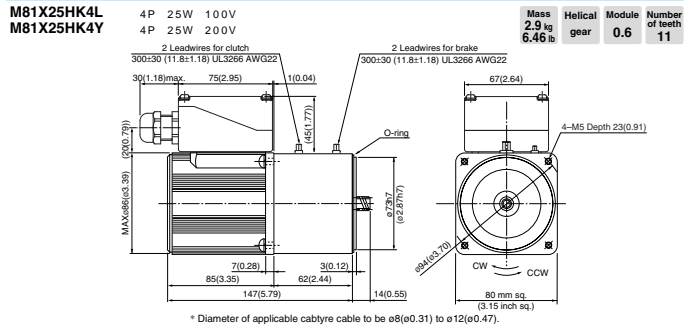

Capacitor (dimensions) [attachment]

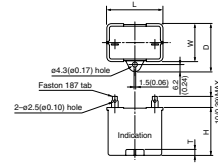

Capacitor dimension list

Model number of motor	Model number of capacitor (attachment)	L	W	D	H	T	Capacitor cap (option)
M81X25HK4L	M0PC6M20	39.5 (1.56)	17.5 (0.69)	28 (1.10)	30.5 (1.20)	4 (0.16)	M0PC3917
M81X25HK4Y	M0PC1.5M40	39.5 (1.56)	22 (0.87)	32.5 (1.28)	32.5 (1.28)	4 (0.16)	M0PC3922

Gear head (dimensions)

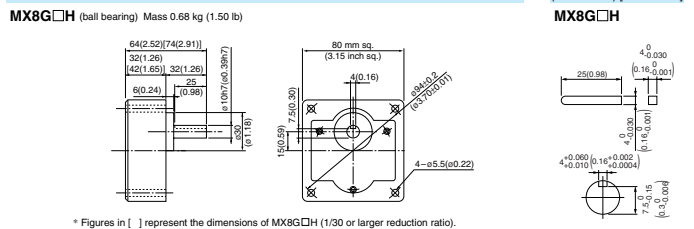

Induction motor
 Reversible motor
 3-phase motor
 Electromagnetic brake motor
 Variable speed induction motor
 Variable speed reversible motor
 Variable speed synchronous motor
 Variable speed unit motor
 C&B motor
 2-pole round shaft
 Gear head
 Gear head -high (U.S.A.)

C&B motor (induction motor sealed connector)

90 mm (3.54 inch) sq. 40 W

Specifications

Size	Motor model No.	Motor characteristics											
		Number of pole (P)	Output (W)	Voltage (V)	Frequency (Hz)	Rating (min)	Rating			Starting current (A)	Starting torque N-m (oz-in)	Capacitor (μF) (rated voltage)	
							Input (W)	Current (A)	Speed (min ⁻¹)				Torque N-m (oz-in)
90 mm sq.	M91X40HK4L	4	40	100	50	Cont.	78	0.86	1225	0.30(42.5)	1.5	0.24(34.0)	10 (200V)
							72	0.72	1550	0.25(35.4)	1.5	0.25(35.4)	
	M91X40HK4Y	4	40	200	50	Cont.	79	0.43	1250	0.30(42.5)	0.83	0.25(35.4)	2.5 (400V)
							72	0.36	1575	0.24(34.0)	0.76	0.25(35.4)	

Size	Motor model No.	Clutch and brake characteristics						
		Clutch/Brake	Static friction torque N-m (oz-in)	Rating Voltage (DC-V)	Capacity W About 75°C	Response time		
						Armature absorbing time (ms)	Armature release time (ms)	Actual torque start time (ms)
90 mm sq.	M91X40HK4L	Clutch	1.47 (208)	24	7	15	25	20
		Brake			5			
	M91X40HK4Y	Clutch			7			
		Brake			5			

(Make selection while referring to the output selection diagrams for C&B motor shown on pages B-346 to 347.)

Reduction ratio	Speed (min ⁻¹)																									
	3	3.6	5	6	7.5	9	10	12.5	15	18	20	25	30	36	50	60	75	90	100	120	150	180				
50Hz	500	416.7	300	250	200	166.7	150	120	100	83.3	75	60	50	41.7	30	25	20	16.7	15	12.5	10	8.3				
60Hz	600	500	360	300	240	200	180	144	120	100	90	72	60	50	36	30	24	20	18	15	12	10				
Applicable gear head	MX9G3H to MX9G180H (ball bearing)											Same as motor rotational direction					Reverse to motor rotational direction					Same as motor rotational direction				

Connection diagram

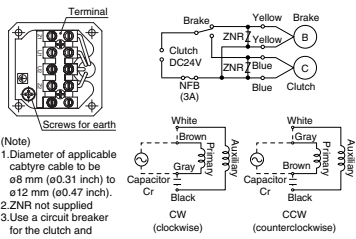

* Please read your User's manual carefully so that you will understand the operation and safety precautions before attempting to operate the system.

Motor (dimensions)

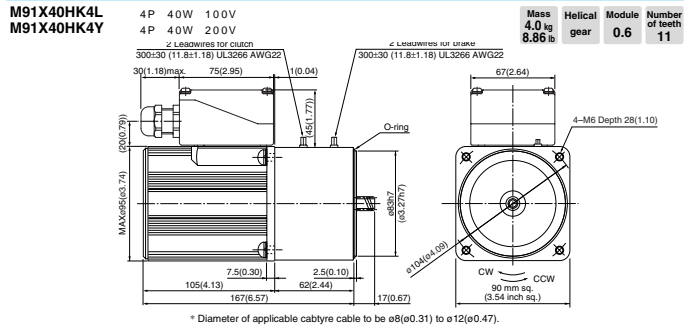

Capacitor (dimensions) [attachment]

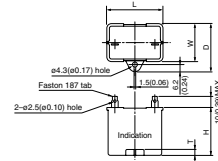

Capacitor dimension list Unit: upper (mm) / lower (inch)

Model number of motor	Model number of capacitor (attachment)	L	W	D	H	T	Capacitor cap (option)
M91X40HK4L	M0PC10M20	39.5 (1.56)	26.7 (1.05)	37 (1.46)	32 (1.26)	4 (0.16)	M0PC3926
M91X40HK4Y	M0PC2.5M40	43.7 (1.72)	24 (0.94)	34.5 (1.36)	34.5 (1.36)	4 (0.16)	M0PC5026

Gear head (dimensions)

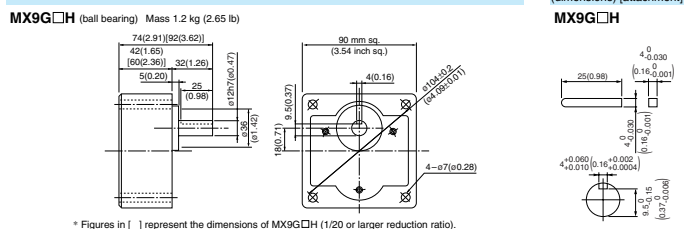

C&B motor (induction motor sealed connector)

90 mm (3.54 inch) sq. 90 W

Specifications

Size	Motor model No.	Motor characteristics										
		Number of pole (P)	Output (W)	Voltage (V)	Frequency (Hz)	Rating (min)	Rating			Starting current (A)	Starting torque N-m (oz-in)	Capacitor (µF) (rated voltage)
							Input (W)	Current (A)	Speed (min ⁻¹)			
90 mm sq.	M91Z90HK4L	4	90	100	50	Cont.	153	1.6	1325	0.65(92.1)	3.3	25 (200V)
							160	1.6	1625	0.53(75.1)	3.0	
	M91Z90HK4Y	4	90	200	50	Cont.	150	0.75	1325	0.62(87.8)	1.7	5.8 (400V)
							160	0.80	1625	0.51(72.2)	1.5	

Size	Motor model No.	Clutch and brake characteristics						
		Static friction torque N-m (oz-in)	Rating Voltage (DC-V)	Capacity W About 75°C	Response time			
					Armature absorbing time (ms)	Armature release time (ms)	Actual torque start time (ms)	
90 mm sq.	M91Z90HK4L	Clutch	1.47 (208)	24	7	15	25	20
		Brake			5			
	M91Z90HK4Y	Clutch			7			
		Brake			5			

(Make selection while referring to the output selection diagrams for C&B motor shown on pages B-346 to 347.)

Reduction ratio	Speed (min ⁻¹)																						
	3	3.6	5	6	7.5	9	10	12.5	15	18	20	25	30	36	50	60	75	90	100	120	150	180	200
50Hz	500	416.7	300	250	200	186.7	150	120	100	83.3	75	60	50	41.7	30	25	20	16.7	15	12.5	10	8.3	7.5
60Hz	600	500	360	300	240	200	180	144	120	100	90	72	60	50	36	30	24	20	18	15	12	10	9

Applicable gear head	Rotational direction	Reverse to motor rotational direction	Same as motor rotational direction	Reverse to motor rotational direction
MY9G3H to MY9G200H (ball bearing)	Same as motor rotational direction	Reverse to motor rotational direction	Same as motor rotational direction	Reverse to motor rotational direction

Connection diagram

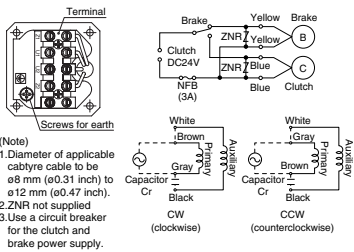

* Please read your User's manual carefully so that you will understand the operation and safety precautions before attempting to operate the system.

Motor (dimensions)

Scale: 1/3, Unit: mm (inch)

Motor	4P 90W 100V	4P 90W 200V	Mass	Helical gear	Module	Number of teeth
M91Z90HK4L	4P 90W 100V		4.5 kg		0.8	11
M91Z90HK4Y		4P 90W 200V	9.92 lb			

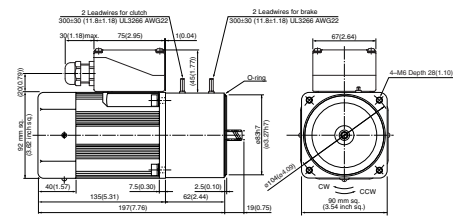

* Diameter of applicable cable to be ø8(ø0.31) to ø12(ø0.47).

Capacitor (dimensions) [attachment]

Unit: mm (inch)

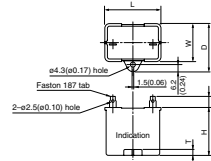

Capacitor dimension list

Unit: upper (mm) / lower (inch)

Model number of motor	Model number of capacitor (attachment)	L	W	D	H	T	Capacitor cap (option)
M91Z90HK4L	M0PC25M20	50.2 (1.98)	31 (1.22)	41 (1.61)	42 (1.65)	5 (0.20)	M0PC5032
M91Z90HK4Y	M0PCS.8M40	50 (1.97)	30.5 (1.20)	41 (1.61)	41.5 (1.63)	4 (0.16)	M0PC5032

Gear head (dimensions)

Scale: 1/4, Unit: mm (inch)

MY9G□H (ball bearing) Mass 1.5 kg (3.31 lb)

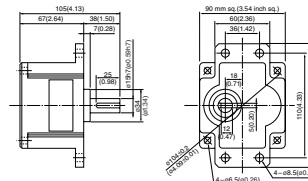

Key and keyway (dimensions) [attachment]

MY9G□M

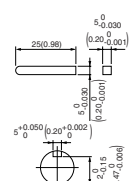

(Note) Because the dimensions may be subject to change, also check the determine dimensions if the gear head is to be used for design.

C&B motor (3-phase motor leadwire)

80 mm (3.15 inch) sq. 25 W

Specifications

Size	Motor model No.	Motor characteristics										
		Number of pole (P)	Output (W)	Voltage (V)	Frequency (Hz)	Rating (min)	Input (W)	Current (A)	Speed (min ⁻¹)	Torque N-m (oz-in)	Starting current (A)	Starting torque N-m (oz-in)
80 mm sq.	M8MX25H4Y	4	25	200	50	Cont.	50	0.25	1350	0.18(25.5)	0.62	0.54(76.5)
					60	Cont.	47	0.22	1625	0.15(21.2)	0.58	0.40(56.6)
		220	50	Cont.	54	0.27	1375	0.18(25.5)	0.67	0.66(93.5)		
			60	Cont.	49	0.23	1650	0.15(21.2)	0.64	0.50(70.8)		

Size	Motor model No.	Clutch and brake characteristics						
		Static friction torque N-m (oz-in)	Rating Voltage (DC-V)	Capacity W About 75°C	Armature absorbing time (ms)	Armature release time (ms)	Actual torque start time (ms)	
80 mm sq.	M8MX25H4Y	Clutch	0.980 (139)	24	7	15	25	20
		Brake						
		Clutch						
		Brake						

Motor (dimensions)

Scale: 1/3, Unit: mm (inch)

M8MX25H4Y 4P 25W 200/220V

Mass	Helical gear	Module	Number of teeth
2.5 kg 5.80 lb	0.6	11	

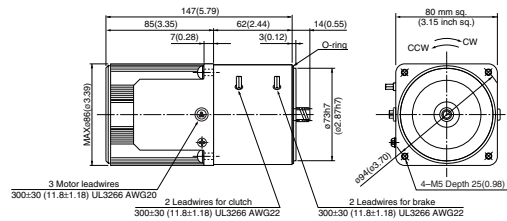

(Make selection while referring to the output selection diagrams for C&B motor shown on pages B-346 to 347.)

Reduction ratio	3	3.6	5	6	7.5	9	10	12.5	15	18	20	25	30	36	50	60	75	90	100	120	150	180																		
Speed (min ⁻¹)	50Hz	500	416.7	300	250	200	166.7	150	120	100	83.3	75	60	50	41.7	30	25	20	16.7	15	12.5	10	8.3																	
60Hz	600	500	360	300	240	200	180	144	120	100	90	72	60	50	36	30	24	20	18	15	12	10																		
Applicable gear head	MX8G3H to MX8G180H (ball bearing)										Same as motor rotational direction										Reverse to motor rotational direction										Same as motor rotational direction									

Connection diagram

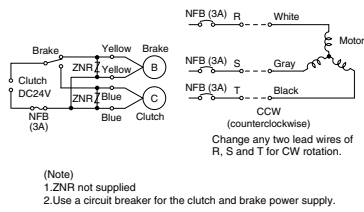

Gear head (dimensions)

Scale: 1/3, Unit: mm (inch)

MX8G□H (ball bearing) Mass 0.68 kg (1.50 lb)

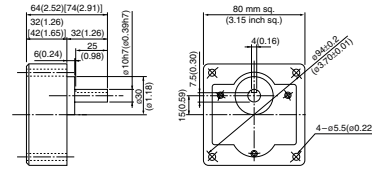

Key and keyway (dimensions) [attachment]

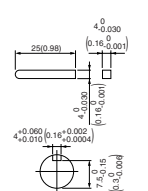

* Figures in [] represent the dimensions of MX8G□H (1/30 or larger reduction ratio).

(Note) Because the dimensions may be subject to change, also check the determinate dimensions if the gear head is to be used for design.

C&B motor (3-phase motor leadwire)

90 mm (3.54 inch) sq. 40 W

Specifications

Size	Motor model No.	Motor characteristics										
		Number of pole (P)	Output (W)	Voltage (V)	Frequency (Hz)	Rating (min)	Input (W)	Current (A)	Speed (min ⁻¹)	Torque N-m (oz-in)	Starting current (A)	Starting torque N-m (oz-in)
90 mm sq.	M9MX40H4Y	4	40	200	50	Cont.	69	0.31	1350	0.28(39.7)	0.90	0.72(102)
				60	60	68	0.29	1625	0.24(34.0)	0.82	0.51(72.2)	
		220	50	Cont.	70	0.32	1375	0.27(38.2)	1.0	0.88(125)		
			60	66	0.28	1675	0.23(32.6)	0.91	0.63(89.2)			

Size	Motor model No.	Clutch and brake characteristics						
		Static friction torque N-m (oz-in)	Rating Voltage (DC-V)	Capacity W About 75°C	Armature absorbing time (ms)	Armature release time (ms)	Actual torque start time (ms)	
90 mm sq.	M9MX40H4Y	Clutch	1.47 (208)	24	7	15	25	20
		Brake						
		Clutch						
		Brake						

Motor (dimensions)

Scale: 1/3, Unit: mm (inch)

M9MX40H4Y 4P 40W 200/220V

Mass	Helical gear	Module	Number of teeth
3.6 kg 7.98 lb	0.6	11	

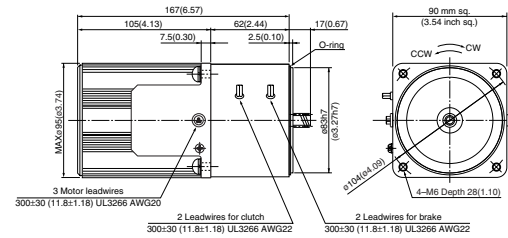

(Make selection while referring to the output selection diagrams for C&B motor shown on pages B-346 to 347.)

Reduction ratio	3	3.6	5	6	7.5	9	10	12.5	15	18	20	25	30	36	50	60	75	90	100	120	150	180	
Speed (min ⁻¹)	50Hz	500	416.7	300	250	200	186.7	150	120	100	83.3	75	60	50	41.7	30	25	20	16.7	15	12.5	10	8.3
60Hz	600	500	360	300	240	200	180	144	120	100	90	72	60	50	36	30	24	20	18	15	12	10	
Applicable gear head	MX9G3H to MX9G180H (ball bearing)											Same as motor rotational direction											
Additional direction	Reversible											Reverse to motor rotational direction											

Connection diagram

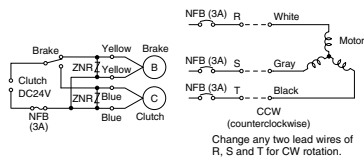

- (Note)
 1. ZNR not supplied
 2. Use a circuit breaker for the clutch and brake power supply.

* Please read your User's manual carefully so that you will understand the operation and safety precautions before attempting to operate the system.

Gear head (dimensions)

Scale: 1/3, Unit: mm (inch)

MX9G□H (ball bearing) Mass 1.2 kg (2.65 lb)

Key and keyway (dimensions) [attachment]
 MX9G□H

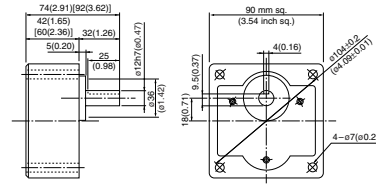

* Figures in [] represent the dimensions of MX9G□H (1/20 or larger reduction ratio).
 (Note) Because the dimensions may be subject to change, also check the determinate dimensions if the gear head is to be used for design.

C&B motor (3-phase motor leadwire)

90 mm (3.54 inch) sq. 60 W

Specifications

Size	Motor model No.	Motor characteristics										
		Number of pole (P)	Output (W)	Voltage (V)	Frequency (Hz)	Rating (min)	Rating				Starting current (A)	Starting torque N-m (oz-in)
							Input (W)	Current (A)	Speed (min ⁻¹)	Torque N-m (oz-in)		
90 mm sq.	M9MZ60H4Y	4	60	200	50	Cont.	101	0.45	1350	0.42(59.5)	1.3	1.0(142)
					60		96	0.41	1625	0.35(49.6)	1.2	0.69(97.7)
					220	Cont.	103	0.46	1375	0.41(58.1)	1.5	1.2(170)
		50	Cont.	98	0.40	1650	0.34(48.2)	1.3	0.87(123)			

Size	Motor model No.	Clutch and brake characteristics						
		Clutch/Brake	Static friction torque N-m (oz-in)	Rating Voltage (DC-V)	Capacity W About 75°C	Response time		
						Armature absorbing time (ms)	Armature release time (ms)	Actual torque start time (ms)
90 mm sq.	M9MZ60H4Y	Clutch	1.47 (208)	24	7	15	25	20
		Brake						
		Clutch						
		Brake						

Motor (dimensions)

Scale: 1/4, Unit: mm (inch)

M9MZ60H4Y 4P 60W 200/220V

Mass **3.9 kg** 8.66 lb
Helical gear **0.8**
Module **1.1**
Number of teeth **11**

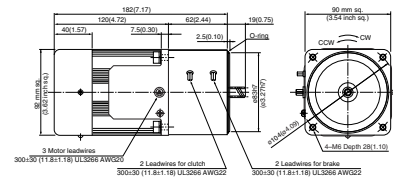

(Make selection while referring to the output selection diagrams for C&B motor shown on pages B-346 to 347.)

Reduction ratio	Speed (min ⁻¹)																								
	50Hz	3	3.6	5	6	7.5	9	10	12.5	15	18	20	25	30	36	50	60	75	90	100	120	150	180	200	
50Hz	500	416.7	300	250	200	166.7	150	120	100	83.3	75	60	50	41.7	30	25	20	16.7	15	12.5	10	8.3	7.5		
60Hz	600	500	360	300	240	200	180	144	120	100	90	72	60	50	36	30	24	20	18	15	12	10	9		
Applicable gear head	MY9G3H to MY9G200H (ball bearing)		Rotational direction Same as motor rotational direction					Reverse to motor rotational direction					Same as motor rotational direction					Reverse to motor rotational direction							

Connection diagram

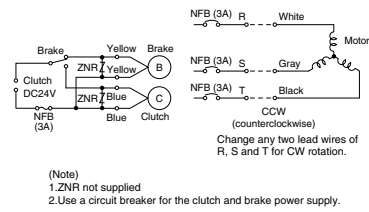

* Please read your User's manual carefully so that you will understand the operation and safety precautions before attempting to operate the system.

Gear head (dimensions)

Scale: 1/4, Unit: mm (inch)

MY9G□H (ball bearing) Mass 1.5 kg (3.31 lb)

Key and keyway (dimensions) [attachment]

MY9G□M

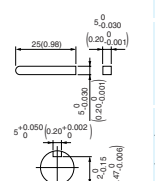
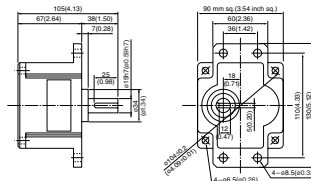

(Note) Because the dimensions may be subject to change, also check the determinate dimensions if the gear head is to be used for design.

C&B motor (3-phase motor leadwire)

90 mm (3.54 inch) sq. 90 W

Specifications

Size	Motor model No.	Motor characteristics										
		Number of pole (P)	Output (W)	Voltage (V)	Frequency (Hz)	Rating (min)	Rating				Starting current (A)	Starting torque N-m (oz-in)
							Input (W)	Current (A)	Speed (min ⁻¹)	Torque N-m (oz-in)		
90 mm sq.	M9MZ90H4Y	4	90	200	50	Cont.	141	0.62	1350	0.63(89.2)	2.0	1.6(227)
				60	60	Cont.	137	0.56	1625	0.53(75.1)	1.8	1.1(156)
		220	50	Cont.	143	0.65	1400	0.62(87.8)	2.2	2.0(283)		
			60	Cont.	137	0.56	1650	0.52(73.6)	2.0	1.4(198)		

Size	Motor model No.	Clutch and brake characteristics						
		Clutch/Brake	Static friction torque N-m (oz-in)	Rating Voltage (DC-V)	Capacity W About 75°C	Response time		
						Armature absorbing time (ms)	Armature release time (ms)	Actual torque start time (ms)
90 mm sq.	M9MZ90H4Y	Clutch	1.47 (208)	24	7	15	25	20
		Brake						
		Clutch						
		Brake						

Motor (dimensions)

Scale: 1/4, Unit: mm (inch)

M9MZ90H4Y 4P 90W 200/220V

Mass 4.1 kg 9.1 lb
Helical gear 0.8
Module 11
Number of teeth 11

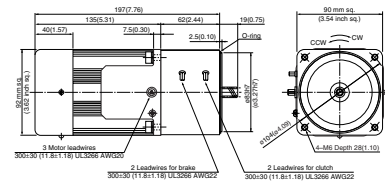

(Make selection while referring to the output selection diagrams for C&B motor shown on pages B-346 to 347.)

Reduction ratio	Speed (min ⁻¹)																						
	3	3.6	5	6	7.5	9	10	12.5	15	18	20	25	30	36	50	60	75	90	100	120	150	180	200
50Hz	500	416.7	300	250	200	186.7	150	120	100	83.3	75	60	50	41.7	30	25	20	16.7	15	12.5	10	8.3	7.5
60Hz	600	500	360	300	240	200	180	144	120	100	90	72	60	50	36	30	24	20	18	15	12	10	9

Applicable gear head	MY9G3H to MY9G200H (ball bearing)	Rotational direction	Reverse to motor rotational direction		
			Same as motor rotational direction	Reverse to motor rotational direction	
		Same as motor rotational direction	Reverse to motor rotational direction	Same as motor rotational direction	Reverse to motor rotational direction

Connection diagram

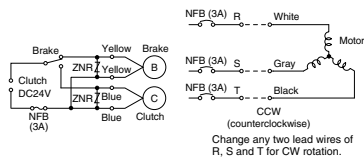

(Note)
1. ZNR not supplied
2. Use a circuit breaker for the clutch and brake power supply.

* Please read your User's manual carefully so that you will understand the operation and safety precautions before attempting to operate the system.

Gear head (dimensions)

Scale: 1/4, Unit: mm (inch)

MY9G□H (ball bearing) Mass 1.5 kg (3.31 lb)

Key and keyway (dimensions) [attachment]

MY9G□M

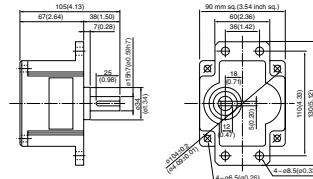

(Note) Because the dimensions may be subject to change, also check the determinate dimensions if the gear head is to be used for design.

Induction motor
Reversible motor
3-phase motor
Electromagnetic brake motor
Variable speed induction motor
Variable speed reversible motor
Variable speed inverter motor
Variable speed unit motor
C&B motor
2-pole round shaft
Gear head
Gear head -high (U.S.A.)

C&B motor (3-phase motor sealed connector)

80 mm (3.15 inch) sq. 25 W

Specifications

Size	Motor model No.	Motor characteristics										
		Number of pole (P)	Output (W)	Voltage (V)	Frequency (Hz)	Rating (min)	Input (W)	Current (A)	Speed (min ⁻¹)	Torque N-m (oz-in)	Starting current (A)	Starting torque N-m (oz-in)
80 mm sq.	M8MX25HK4Y	4	25	200	50	Cont.	50	0.25	1350	0.18(25.5)	0.62	0.54(76.5)
					60	Cont.	47	0.22	1625	0.15(21.2)	0.58	0.40(56.6)
				220	50	Cont.	54	0.27	1375	0.18(25.5)	0.67	0.66(93.5)
					60	Cont.	49	0.23	1650	0.15(21.2)	0.64	0.50(70.8)

Size	Motor model No.	Clutch and brake characteristics						
		Clutch/Brake	Static friction torque N-m (oz-in)	Rating Voltage (DC-V)	Capacity W About 75°C	Response time Armature absorbing time (ms)	Response time Armature release time (ms)	Actual torque start time (ms)
80 mm sq.	M8MX25HK4Y	Clutch	0.980 (139)	24	7	15	25	20
		Brake						
		Clutch						
		Brake						

Motor (dimensions)

M8MX25HK4Y 4P 25W 200/220V

Scale: 1/3, Unit: mm (inch)

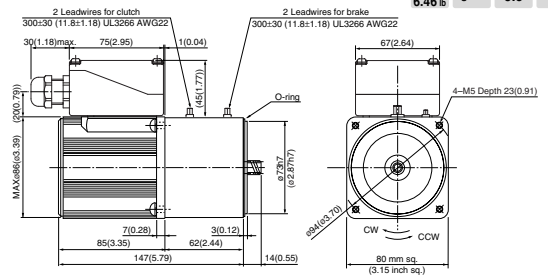

* Diameter of applicable cable to be ø8(ø0.31) to ø12(ø0.47).

(Make selection while referring to the output selection diagrams for C&B motor shown on pages B-346 to 347.)

Reduction ratio	Speed (min ⁻¹)																											
	3	3.6	5	6	7.5	9	10	12.5	15	18	20	25	30	36	50	60	75	90	100	120	150	180						
50Hz	500	416.7	300	250	200	166.7	150	120	100	83.3	75	60	50	41.7	30	25	20	16.7	15	12.5	10	8.3						
60Hz	600	500	360	300	240	200	180	144	120	100	90	72	60	50	36	30	24	20	18	15	12	10						
Applicable gear head	MX8G3H to MX8G180H (ball bearing)										Same as motor rotational direction						Reverse to motor rotational direction						Same as motor rotational direction					

Connection diagram

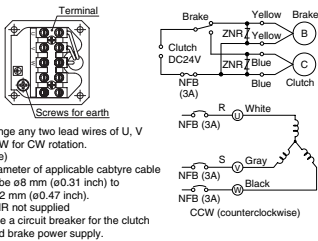

Change any two lead wires of U, V and W for CW rotation.
(Note)
1. Diameter of applicable cable to be ø8 mm (ø0.31 inch) to ø12 mm (ø0.47 inch).
2. ZNR not supplied
3. Use a circuit breaker for the clutch and brake power supply.

* Please read your User's manual carefully so that you will understand the operation and safety precautions before attempting to operate the system.

Gear head (dimensions)

Scale: 1/3, Unit: mm (inch)

MX8G□H (ball bearing) Mass 0.68 kg (1.50 lb)

Key and keyway (dimensions) [attachment]

MX8G□H

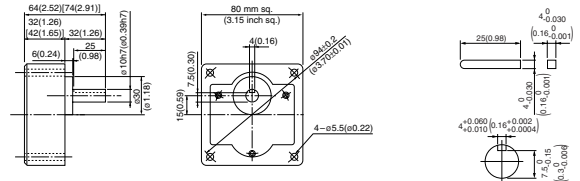

* Figures in [] represent the dimensions of MX8G□H (1/30 or larger reduction ratio).

(Note) Because the dimensions may be subject to change, also check the determinate dimensions if the gear head is to be used for design.

Induction motor
Reversible motor
3-phase motor
Electromagnetic brake motor
Variable speed induction motor
Variable speed reversible motor
Variable speed asynchronous motor
Variable speed synchronous motor
C&B motor
2-pole round shaft motor
Gear head
Gear head -high (U.S.A.)

C&B motor (3-phase motor sealed connector)

90 mm (3.54 inch) sq. 40 W

Specifications

Size	Motor model No.	Number of pole (P)	Output (W)	Voltage (V)	Frequency (Hz)	Rating (min)	Motor characteristics					
							Input (W)	Current (A)	Speed (min ⁻¹)	Torque N-m (oz-in)	Starting current (A)	Starting torque N-m (oz-in)
90 mm sq.	M9MX40HK4Y	4	40	200	50	Cont.	69	0.31	1350	0.28(39.7)	0.90	0.72(101)
						60	68	0.29	1625	0.24(34.0)	0.82	0.51(72.2)
				220	50	Cont.	70	0.32	1375	0.27(38.2)	1.0	0.88(125)
						60	66	0.28	1675	0.23(32.6)	0.91	0.63(89.2)

Size	Motor model No.		Clutch and brake characteristics					
			Static friction torque N-m (oz-in)	Rating Voltage (DC-V)	Capacity W About 75°C	Response time Armature absorbing time (ms)	Armature release time (ms)	Actual torque start time (ms)
90 mm sq.	M9MX40HK4Y	Clutch	1.47 (208)	24	7	15	25	20
		Brake			5			
		Clutch			7			
		Brake			5			

(Make selection while referring to the output selection diagrams for C&B motor shown on pages B-346 to 347.)

Reduction ratio	3 3.6 5 6 7.5 9 10 12.5 15 18 20 25 30 36 50 60 75 90 100 120 150 180																							
	Speed (min ⁻¹)	50Hz	60Hz	500	416.7	300	250	200	166.7	150	120	100	83.3	75	60	50	41.7	30	25	20	16.7	15	12.5	10
Applicable gear head	MX9G3H to MX9G180H (ball bearing)	Rotational direction	Same as motor rotational direction										Reverse to motor rotational direction							Same as motor rotational direction				

Connection diagram

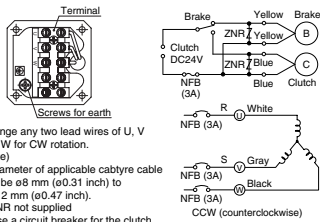

Change any two lead wires of U, V and W for CW rotation.
 (Note)
 1. Diameter of applicable cable to be ø8 mm (ø0.31 inch) to ø12 mm (ø0.47 inch).
 2. ZNR not supplied.
 3. Use a circuit breaker for the clutch and brake power supply.

* Please read your User's manual carefully so that you will understand the operation and safety precautions before attempting to operate the system.

Motor (dimensions)

Scale: 1/3, Unit: mm (inch)

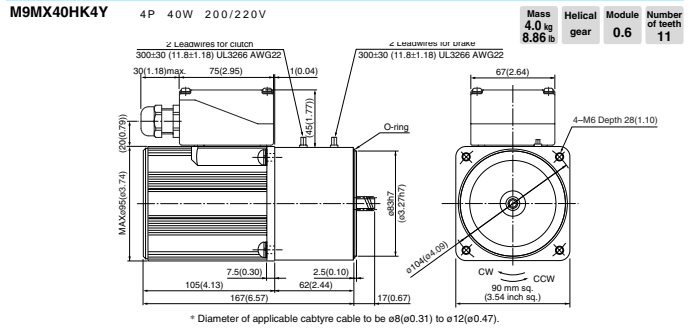

* Diameter of applicable cable to be ø8(ø0.31) to ø12(ø0.47).

Gear head (dimensions)

Scale: 1/3, Unit: mm (inch)

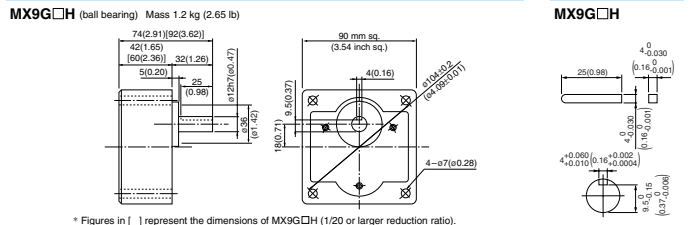

* Figures in [] represent the dimensions of MX9G□H (1/20 or larger reduction ratio).
 (Note) Because the dimensions may be subject to change, also check the determine dimensions if the gear head is to be used for design.

Induction motor
 Reversible motor
 3-phase motor
 Electronic brake
 Variable speed induction motor
 Variable speed reversible motor
 Variable speed synchronous motor
 Variable speed unit motor
 C&B motor
 2-pole round shaft
 Gear head
 Gear head -high (U.S.A.)

C&B motor (Variable Speed motor leadwire)

60 mm (2.36 inch) sq. 6 W

Specifications

Size	Motor model No.	Motor characteristics										
		Number of pole (P)	Output (W)	Voltage (V)	Frequency (Hz)	Rating (min)	Input (W)	Current (A)	Speed (min ⁻¹)	Torque N-m (oz-in)	Starting current (A)	Starting torque N-m (oz-in)
60 mm sq.	M61X6HV4L	4	6	100	50	Cont.	90 to 1400	0.032 (4.53)	0.025 (3.54)	0.30	0.037 (5.23)	2.5 (200V)
	60				90 to 1700		0.6 (400V)					
	50				90 to 1400							
	60				90 to 1700							

Size	Motor model No.	Clutch and brake characteristics					
		Static friction torque N-m (oz-in)	Rating Voltage (DC-V)	Capacity W About 75°C	Armature absorbing time (ms)	Armature release time (ms)	Actual torque start time (ms)
60 mm sq.	M61X6HV4L	0.294 (41.6)	24	4	15	25	20
	Clutch						
	Brake						
	M61X6HV4Y						

(Make selection while referring to the output selection diagrams for C&B motor shown on pages B-346 to 347.)

Reduction ratio	3	3.6	5	6	7.5	9	10	12.5	15	18	20	25	30	36	50	60	75	90	100	120	150	180
Speed (min ⁻¹)	50Hz 500	416.7	300	250	200	166.7	150	120	100	83.3	75	60	50	41.7	30	25	20	16.7	15	12.5	10	8.3
	60Hz 600	500	360	300	240	200	180	144	120	100	90	72	60	50	36	30	24	20	18	15	12	10
Applicable gear head	MX6G3H to MX6G180H (ball bearing)											Same as motor rotational direction										
Rotational direction	Same as motor rotational direction											Reverse to motor rotational direction										

Connection diagram

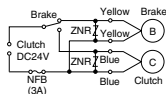

- (Note)
 1. ZNR not supplied
 2. Use a circuit breaker for the clutch and brake power supply.
 * For the connection diagram showing wiring with the speed controller, refer to pages C-6 to C-35.

* Please read your User's manual carefully so that you will understand the operation and safety precautions before attempting to operate the system.

Motor (dimensions)

Scale: 1/3, Unit: mm (inch)

M61X6HV4L 4P 6W 100V
 M61X6HV4Y 4P 6W 200V

Mass 1.3 kg 2.80 lb
 Helical gear
 Module 0.5
 Number of teeth 10

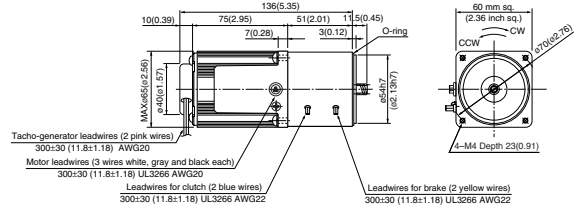

Capacitor (dimensions) [attachment]

Unit: mm (inch)

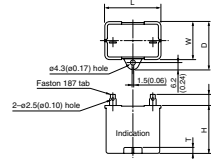

Capacitor dimension list

Unit: upper (mm) / lower (inch)

Model number of motor	Model number of capacitor (attachment)	L	W	D	H	T	Capacitor cap (option)
M61X6HV4L	M0PC2.5M20	39.5 (1.56)	16 (0.63)	26.5 (1.04)	30.5 (1.20)	4 (0.16)	M0PC3917
M61X6HV4Y	M0PC0.6M40	39.5 (1.56)	16.5 (0.64)	27 (1.06)	27 (1.06)	4 (0.16)	M0PC3917

Gear head (dimensions)

Scale: 1/3, Unit: mm (inch)

MX6G□□ (ball bearing) Mass 0.34 kg (0.75 lb): Output shaft D cut

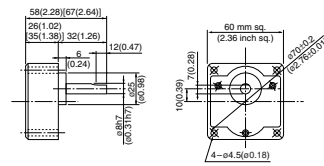

* Figures in [] represent the dimensions of MX6G□□ (1/30 or larger reduction ratio).

(Note) Because the dimensions may be subject to change, also check the determinate dimensions if the gear head is to be used for design.

Gear head combination B-404 Controls C-4 Option D-2

Induction motor
 Reversible motor
 3-phase motor
 Electronic brake motor
 Variable speed induction motor
 Variable speed reversible motor
 Variable speed synchronous motor
 Variable speed unit motor
 C&B motor
 2-pole round shaft
 Gear head
 Gear head -high (U.S.A.)

C&B motor (Variable Speed motor leadwire)

70 mm (2.76 inch) sq. 15 W

Specifications

Size	Motor model No.	Motor characteristics									
		Number of pole (P)	Output (W)	Voltage (V)	Frequency (Hz)	Rating (min)	Variable speed range Speed (min ⁻¹)	Permissible Torque N·m (oz-in) at 1200 min ⁻¹	Starting current (A)	Starting torque N·m (oz-in)	Capacitor (μF) (rated voltage)
70 mm sq.	M71X15HV4L	4	15	100	50	Cont.	90 to 1400	0.069 (12.6)	0.029 (4.11)	0.60	5 (200V)
	90 to 1700										
	200			50	Cont.	90 to 1400	0.069 (12.6)	0.029 (4.11)	0.30 (9.63)	1.3 (400V)	
						90 to 1700					

Size	Motor model No.	Clutch and brake characteristics					
		Static friction torque N·m (oz-in)	Rating Voltage (DC-V)	Capacity W About 75°C	Response time Armature absorbing time (ms)	Actual torque start time (ms)	
70 mm sq.	M71X15HV4L	0.294 (41.63)	24	4	15	25	20
	Brake						
	M71X15HV4Y	Clutch	2	4	15	25	20
		Brake					

(Make selection while referring to the output selection diagrams for C&B motor shown on pages B-346 to 347.)

Reduction ratio	Speed (min ⁻¹)																										
	3	3.6	5	6	7.5	9	10	12.5	15	18	20	25	30	36	50	60	75	90	100	120	150	180					
50Hz	500	416.7	300	250	200	166.7	150	120	100	83.3	75	60	50	41.7	30	25	20	16.7	15	12.5	10	8.3					
60Hz	600	500	360	300	240	200	180	144	120	100	90	72	60	50	36	30	24	20	18	15	12	10					
Applicable gear head	MX7G3H to MX7G180H (ball bearing)											Same as motor rotational direction						Reverse to motor rotational direction					Same as motor rotational direction				

Connection diagram

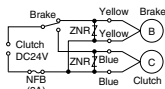

- (Note)
 1. ZNR not supplied
 2. Use a circuit breaker for the clutch and brake power supply.
 * For the connection diagram showing wiring with the speed controller, refer to pages C-6 to C-35.

* Please read your User's manual carefully so that you will understand the operation and safety precautions before attempting to operate the system.

Motor (dimensions)

M71X15HV4L 4P 15W 100V
 M71X15HV4Y 4P 15W 200V

Scale: 1/3, Unit: mm (inch)

Mass 1.8 kg 3.88 lb
 Helical gear 0.5
 Module 0.5
 Number of teeth 10

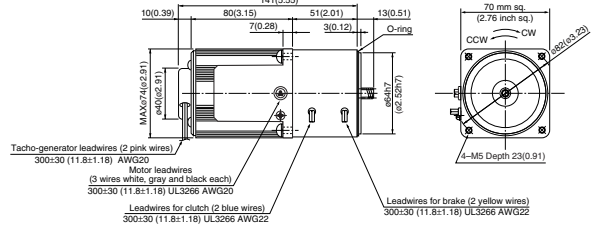

Capacitor (dimensions) [attachment]

Unit: mm (inch)

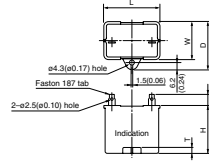

Capacitor dimension list

Model number of motor	Model number of capacitor (attachment)	L	W	D	H	T	Capacitor cap (option)
M71X15HV4L	M0PC5M20	39.5 (1.56)	16 (0.63)	26.5 (1.04)	30.5 (1.20)	4 (0.16)	M0PC3917
M71X15HV4Y	M0PC1.3M40	39.5 (1.56)	16.3 (0.72)	29 (1.14)	29 (1.14)	4 (0.16)	M0PC3922

Gear head (dimensions)

Scale: 1/3, Unit: mm (inch)

MX7G□H (ball bearing) Mass 0.54 kg (1.19 lb)

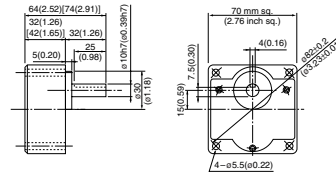

Key and keyway (dimensions) [attachment]

MX7G□H

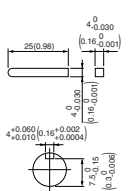

* Figures in [] represent the dimensions of MX7G□H (1/30 or larger reduction ratio).

(Note) Because the dimensions may be subject to change, also check the determinate dimensions if the gear head is to be used for design.

Gear head combination B-404 Controls C-4 Option D-2

B-391

C&B motor (Variable Speed motor leadwire)

80 mm (3.15 inch) sq. 25 W

Specifications

Size	Motor model No.	Number of pole (P)	Output (W)	Voltage (V)	Frequency (Hz)	Rating (min)	Motor characteristics					
							Variable speed range (min ⁻¹)	Permissible Torque N·m (oz-in) at 1200 min ⁻¹	Starting current (A)	Starting torque N·m (oz-in)	Capacitor (μF) (rated voltage)	
80 mm sq.	M81X25HV4L	4	25	100	50	Cont.	90 to 1400	0.14 (19.8)	0.039 (5.52)	1.0	0.16 (22.7)	8 (200V)
	90 to 1700						2 (400V)					
	50			90 to 1400	2							
				90 to 1700								

Size	Motor model No.	Clutch / Brake	Static friction torque N·m (oz-in)	Rating Voltage (DC-V)	Capacity W About 75°C	Response time		
						Armature absorbing time (ms)	Armature release time (ms)	Actual torque start time (ms)
80 mm sq.	M81X25HV4L	Clutch	0.980 (139)	24	7	15	25	20
	Brake							
	M81X25HV4Y	Clutch						
	Brake							

(Make selection while referring to the output selection diagrams for C&B motor shown on pages B-346 to 347.)

Reduction ratio	3	3.6	5	6	7.5	9	10	12.5	15	18	20	25	30	36	50	60	75	90	100	120	150	180	
Speed (min ⁻¹)	50Hz	500	416.7	300	250	200	166.7	150	120	100	83.3	75	60	50	41.7	30	25	20	16.7	15	12.5	10	8.3
	60Hz	600	500	360	300	240	200	180	144	120	100	90	72	60	50	36	30	24	20	18	15	12	10
Applicable gear head	MX8G3H to MX8G180H (ball bearing)											Same as motor rotational direction											
Additional direction	Reversible											Reverse to motor rotational direction											

Connection diagram

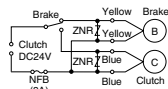

- (Note)
 1. ZNR not supplied
 2. Use a circuit breaker for the clutch and brake power supply.
 * For the connection diagram showing wiring with the speed controller, refer to pages C-6 to C-35.

* Please read your User's manual carefully so that you will understand the operation and safety precautions before attempting to operate the system.

Motor (dimensions)

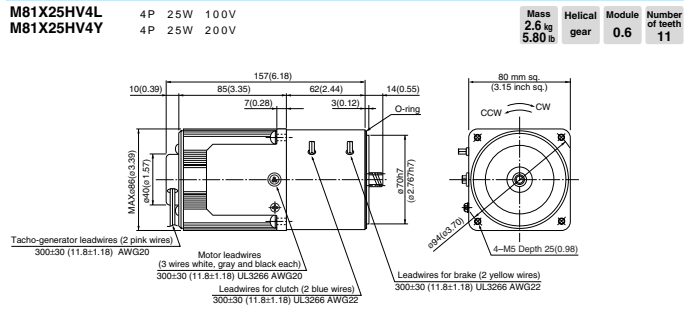

Capacitor (dimensions) [attachment]

Unit: mm (inch)

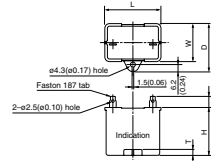

Capacitor dimension list

Model number of motor	Model number of capacitor (attachment)	L	W	D	H	T	Capacitor cap (option)
M81X25HV4L	M0PC8M20	39.5 (1.56)	22 (0.87)	32.5 (1.28)	30.5 (1.20)	4 (0.16)	M0PC3922
M81X25HV4Y	M0PC2M40	39.5 (1.56)	22 (0.87)	32.5 (1.28)	30.5 (1.20)	4 (0.16)	M0PC3922

Gear head (dimensions)

Scale: 1/3, Unit: mm (inch)

MX8G□H (ball bearing) Mass 0.68 kg (1.50 lb)

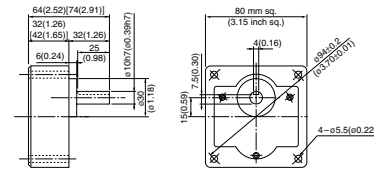

* Figures in [] represent the dimensions of MX8G□H (1/30 or larger reduction ratio).

(Note) Because the dimensions may be subject to change, also check the determinate dimensions if the gear head is to be used for design.

Key and keyway (dimensions) [attachment]

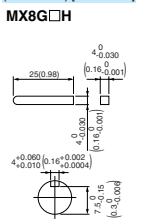

Induction motor
 Reversible motor
 3-phase motor
 Electromagnetic brake motor
 Variable speed induction motor
 Variable speed reversible motor
 Variable speed synchronous motor
 Variable speed unit motor
 C&B motor
 2-pole round shaft motor
 Gear head
 Gear head -high (U.S.A.)

C&B motor (Variable Speed motor leadwire)

90 mm (3.54 inch) sq. 40 W

Specifications

Size	Motor model No.	Number of pole (P)	Output (W)	Voltage (V)	Frequency (Hz)	Rating (min)	Motor characteristics					
							Variable speed range (min ⁻¹)	Permissible Torque N·m (oz·in) at 1200 min ⁻¹ at 90 min ⁻¹	Starting current (A)	Starting torque N·m (oz·in)	Capacitor (μF) (rated voltage)	
90 mm sq.	M91X40HV4L	4	40	100	50	Cont.	90 to 1400	0.30(42.5)	0.049 (6.94)	1.6	0.25 (35.4)	12 (200V)
							90 to 1700	0.24(34.0)				
	M91X40HV4Y	4	40	200	50	Cont.	90 to 1400	0.30(42.5)	0.80	1.6	0.80	3 (400V)
							90 to 1700	0.24(34.0)				

Size	Motor model No.	Clutch/Brake	Static friction torque N·m (oz·in)	Rating Voltage (DC-V)	Capacity W About 75°C	Response time		
						Armature absorbing time (ms)	Armature release time (ms)	Actual torque start time (ms)
90 mm sq.	M91X40HV4L	Clutch	1.47 (208)	24	5	15	25	20
		Brake						
	M91X40HV4Y	Clutch						
		Brake						

(Make selection while referring to the output selection diagrams for C&B motor shown on pages B-346 to 347.)

Reduction ratio	3	3.6	5	6	7.5	9	10	12.5	15	18	20	25	30	36	50	60	75	90	100	120	150	180		
Speed (min ⁻¹)	50Hz	500	416.7	300	250	200	166.7	150	120	100	83.3	75	60	50	41.7	30	25	20	16.7	15	12.5	10	8.3	
	60Hz	600	500	360	300	240	200	180	144	120	100	90	72	60	50	36	30	24	20	18	15	12	10	
Applicable gear head	MX9G3H to MX9G180H (ball bearing)						Same as motor rotational direction						Reverse to motor rotational direction						Same as motor rotational direction					

Connection diagram

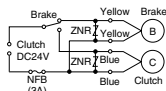

- (Note)
 1. ZNR not supplied
 2. Use a circuit breaker for the clutch and brake power supply.
 * For the connection diagram showing wiring with the speed controller, refer to pages C-6 to C-35.

* Please read your User's manual carefully so that you will understand the operation and safety precautions before attempting to operate the system.

Motor (dimensions)

Scale: 1/3, Unit: mm (inch)

M91X40HV4L 4P 40W 100V
 M91X40HV4Y 4P 40W 200V

Mass 3.6 kg 7.98 lb
 Helical gear 0.6
 Module 11

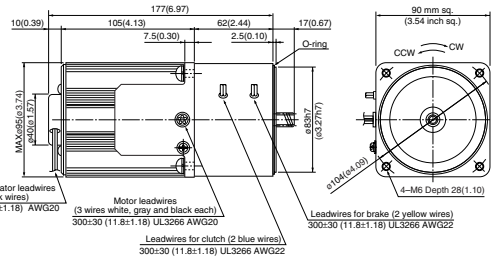

Capacitor (dimensions) [attachment]

Unit: mm (inch)

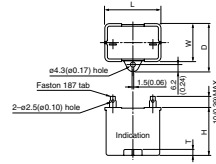

Capacitor dimension list Unit: upper (mm) / lower (inch)

Model number of motor	Model number of capacitor (attachment)	L	W	D	H	T	Capacitor cap (option)
M91X40HV4L	M0PC12M20	39.5 (1.56)	26.7 (1.05)	37 (1.46)	32 (1.26)	4 (0.16)	M0PC3926
M91X40HV4Y	M0PC3M40	43.7 (1.96)	24 (0.94)	34.5 (1.36)	34.5 (1.36)	4 (0.16)	M0PC5026

Gear head (dimensions)

Scale: 1/3, Unit: mm (inch)

MX9G□H (ball bearing) Mass 1.2 kg (2.65 lb)

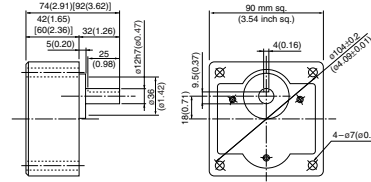

Key and keyway (dimensions) [attachment]

MX9G□H

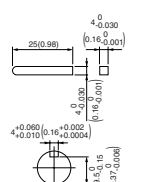

* Figures in [] represent the dimensions of MX9G□H (1/20 or larger reduction ratio).

(Note) Because the dimensions may be subject to change, also check the determinate dimensions if the gear head is to be used for design.

Gear head combination B-404 Controls C-4 Option D-2

Induction motor
 Reversible motor
 3-phase motor
 Electromagnetic brake motor
 Variable speed induction motor
 Variable speed reversible motor
 Variable speed synchronous motor
 Variable speed unit motor
 C&B motor
 2-pole round shaft
 Gear head
 Gear head -high (U.S.A.)

C&B motor (Variable Speed motor leadwire)

90 mm (3.54 inch) sq. 60 W

Specifications

Size	Motor model No.	Number of pole (P)	Output (W)	Voltage (V)	Frequency (Hz)	Rating (min)	Motor characteristics						
							Variable speed range (min ⁻¹)	Permissible Torque N·m (oz·in) at 1200 min ⁻¹	Permissible Torque N·m (oz·in) at 90 min ⁻¹	Starting current (A)	Starting torque N·m (oz·in)	Capacitor (μF) (rated voltage)	
90 mm sq.	M91Z60HV4L	4	60	100	50	Cont.	90 to 1400	0.43(60.9)	0.078 (11.1)	2.3	0.46 (65.1)	20 (200V)	
	60				90 to 1700		0.36(51.0)	5 (400V)					
	200			50	90 to 1400		0.43(60.9)	1.2				2.4	5
				60	90 to 1700		0.36(51.0)						

Size	Motor model No.	Clutch / Brake	Clutch and brake characteristics					
			Static friction torque N·m (oz·in)	Rating Voltage (DC-V)	Capacity W (About 75°C)	Armature absorbing time (ms)	Armature release time (ms)	Actual torque start time (ms)
90 mm sq.	M91Z60HV4L	Clutch	1.47 (208)	24	7	15	25	20
		Brake			5			
		Clutch			7			
		Brake			5			

(Make selection while referring to the output selection diagrams for C&B motor shown on pages B-346 to 347.)

Reduction ratio	3	3.6	5	6	7.5	9	10	12.5	15	18	20	25	30	36	50	60	75	90	100	120	150	180	200	
Speed (min ⁻¹)	50Hz	500	416.7	300	250	200	186.7	150	120	100	83.3	75	60	50	41.7	30	25	20	16.7	15	12.5	10	8.3	7.5
	60Hz	600	500	360	300	240	200	180	144	120	100	90	72	60	50	36	30	24	20	18	15	12	10	9

Applicable gear head	MY9G3H to MY9G200H (ball bearing)	Rotational direction	Reverse to motor rotational direction	Same as motor rotational direction	Reverse to motor rotational direction
----------------------	-----------------------------------	----------------------	---------------------------------------	------------------------------------	---------------------------------------

Connection diagram

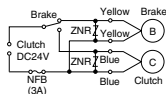

- (Note)
 1. ZNR not supplied
 2. Use a circuit breaker for the clutch and brake power supply.
 * For the connection diagram showing wiring with the speed controller, refer to pages C-6 to C-35.

* Please read your User's manual carefully so that you will understand the operation and safety precautions before attempting to operate the system.

Motor (dimensions)

Scale: 1/4, Unit: mm (inch)

M91Z60HV4L 4P 60W 100V
 M91Z60HV4Y 4P 60W 200V

Mass 4.2 kg 9.33 lb
 Helical gear 0.8
 Module 11
 Number of teeth 11

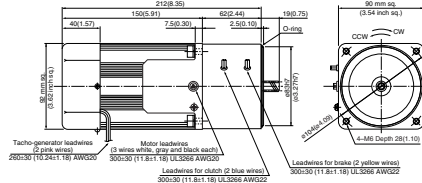

* Diameter of applicable cable to be ø8(ø0.31) to ø12(ø0.47).

Capacitor (dimensions) [attachment]

Unit: mm (inch)

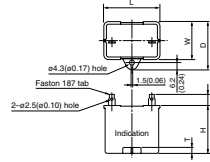

Capacitor dimension list

Model number of motor	Model number of capacitor (attachment)	L	W	D	H	T	Capacitor cap (option)
M91Z60HV4L	M0PC20M20	50.2 (1.98)	26.7 (1.05)	37 (1.46)	36 (1.42)	5 (0.20)	M0PC5026
M91Z60HV4Y	M0PCSM40	50 (1.97)	30.5 (1.20)	41.5 (1.63)	41.5 (1.63)	4 (0.16)	M0PC5032

Gear head (dimensions)

Scale: 1/4, Unit: mm (inch)

MY9G□□ (ball bearing) Mass 1.5 kg (3.31 lb)

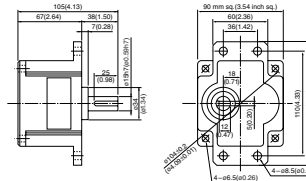

Key and keyway (dimensions) [attachment]

MY9G□□

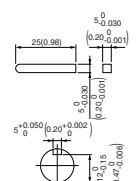

(Note) Because the dimensions may be subject to change, also check the determinate dimensions if the gear head is to be used for design.

C&B motor (Variable Speed motor leadwire)

90 mm (3.54 inch) sq. 90 W

Specifications

Size	Motor model No.	Number of pole (P)	Output (W)	Voltage (V)	Frequency (Hz)	Rating (min)	Motor characteristics				Capacitor (μ F) (rated voltage)
							Variable speed range (min ⁻¹)	Permissible Torque N·m (oz·in) at 1200 min ⁻¹	Starting current (A)	Starting torque N·m (oz·in) at 90 min ⁻¹	
90 mm sq.	M91Z90HV4L	4	90	100	50	Cont.	90 to 1400	0.59(83.6)	2.3	0.53(75.1)	25 (200V)
	90 to 1700						0.54(76.5)	0.25 (35.4)			
	200			50	90 to 1400		0.59(83.6)		2.2	0.56(79.3)	
					90 to 1700		0.54(76.5)	1.1			0.59(83.6)

Size	Motor model No.	Clutch	Static friction torque N·m (oz·in)	Rating Voltage (DC-V)	Capacity W About 75°C	Response time			
						Armature absorbing time (ms)	Armature release time (ms)	Actual torque start time (ms)	
90 mm sq.	M91Z90HV4L	Clutch	1.47 (208)	24	7	15	25	20	
	M91Z90HV4Y	Brake							7
		Clutch							7
		Brake							5

(Make selection while referring to the output selection diagrams for C&B motor shown on pages B-346 to 347.)

Reduction ratio	Speed (min ⁻¹)																						
	3	3.6	5	6	7.5	9	10	12.5	15	18	20	25	30	36	50	60	75	90	100	120	150	180	200
50Hz	500	416.7	300	250	200	166.7	150	120	100	83.3	75	60	50	41.7	30	25	20	16.7	15	12.5	10	8.3	7.5
60Hz	600	500	360	300	240	200	180	144	120	100	90	72	60	50	36	30	24	20	18	15	12	10	9
Applicable gear head	MY9G3H to MY9G200H (ball bearing)		Same as motor rotational direction					Reverse to motor rotational direction					Same as motor rotational direction					Reverse to motor rotational direction					

Connection diagram

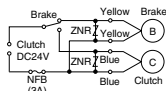

- (Note)
 1. ZNR not supplied
 2. Use a circuit breaker for the clutch and brake power supply.
 * For the connection diagram showing wiring with the speed controller, refer to pages C-6 to C-35.

* Please read your User's manual carefully so that you will understand the operation and safety precautions before attempting to operate the system.

Motor (dimensions)

Scale: 1/4, Unit: mm (inch)

M91Z90HV4L 4P 90W 100V
 M91Z90HV4Y 4P 90W 200V

Mass 4.8 kg 10.6 lb
 Helical gear
 Module 0.8
 Number of teeth 11

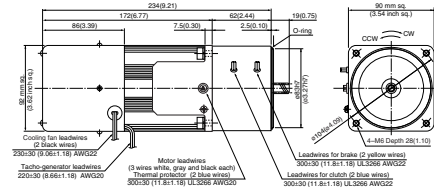

* Diameter of applicable cable to be $\phi 8(\phi 0.31)$ to $\phi 12(\phi 0.47)$.

Capacitor (dimensions) [attachment]

Unit: mm (inch)

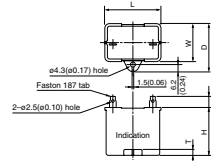

Capacitor dimension list Unit: upper (mm) / lower (inch)

Model number of motor	Model number of capacitor (attachment)	L	W	D	H	T	Capacitor cap (option)
M91Z90HV4L	M0PC25M20	50.2 (1.98)	31 (1.22)	41 (1.61)	42 (1.65)	5 (0.20)	M0PC5032
M91Z90HV4Y	M0PC6.2M38	50 (1.97)	30.5 (1.20)	41 (1.61)	41.5 (1.63)	4 (0.16)	M0PC5032

Gear head (dimensions)

Scale: 1/4, Unit: mm (inch)

MY9G□□ (ball bearing) Mass 1.5 kg (3.31 lb)

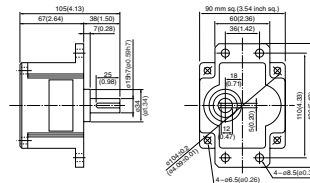

Key and keyway (dimensions) [attachment]

MY9G□□

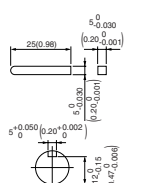

(Note) Because the dimensions may be subject to change, also check the determine dimensions if the gear head is to be used for design.

C&B motor (induction motor leadwire) Gear head combination dimensions
Scale: 1/4, Unit: mm (inch)

60 mm sq. (2.36 inch sq.) 6 W
M61X6H4L + MX6G□H
M61X6H4Y + MX6G□H

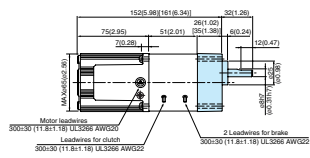

* Figures in [] represent the dimensions of MX6G□H (1/30 or larger reduction ratio).

70 mm sq. (2.76 inch sq.) 15 W
M71X15H4L + MX7G□H
M71X15H4Y + MX7G□H

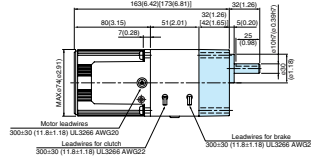

* Figures in [] represent the dimensions of MX7G□H (1/30 or larger reduction ratio).

80 mm sq. (3.15 inch sq.) 25 W
M81X25H4L + MX8G□H
M81X25H4Y + MX8G□H

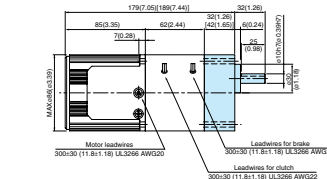

* Figures in [] represent the dimensions of MX8G□H (1/30 or larger reduction ratio).

90 mm sq. (3.54 inch sq.) 40 W
M91X40H4L + MX9G□H
M91X40H4Y + MX9G□H

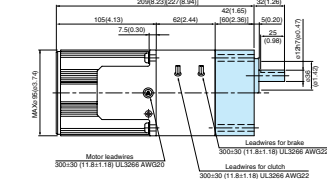

* Figures in [] represent the dimensions of MX9G□H (1/20 or larger reduction ratio).

90 mm sq. (3.54 inch sq.) 60 W
M91Z60H4L + MY9G□H
M91Z60H4Y + MY9G□H

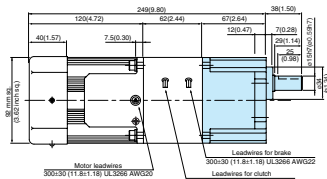

* Please read your User's manual carefully so that you will understand the operation and safety precautions before attempting to operate the system.

C&B motor (induction motor sealed connector) Gear head combination dimensions
Scale: 1/4, Unit: mm (inch)

80 mm sq. (3.15 inch sq.) 25 W
M81X25HK4L + MX8G□H
M81X25HK4Y + MX8G□H

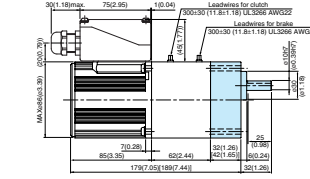

* Figures in [] represent the dimensions of MX8G□H (1/30 or larger reduction ratio).
* Diameter of applicable cable to be ø8(ø0.31) to ø12(ø0.47).

90 mm sq. (3.54 inch sq.) 40 W
M91X40HK4L + MX9G□H
M91X40HK4Y + MX9G□H

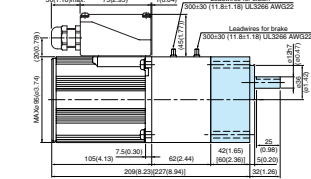

* Figures in [] represent the dimensions of MX9G□H (1/20 or larger reduction ratio).
* Diameter of applicable cable to be ø8(ø0.31) to ø12(ø0.47).

90 mm sq. (3.54 inch sq.) 60 W
M91Z60HK4L + MY9G□H
M91Z60HK4Y + MY9G□H

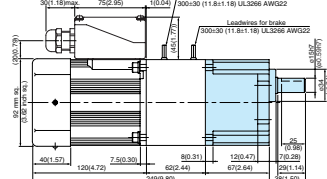

* Diameter of applicable cable to be ø8(ø0.31) to ø12(ø0.47).

90 mm sq. (3.54 inch sq.) 90 W
M91Z90HK4L + MY9G□H
M91Z90HK4Y + MY9G□H

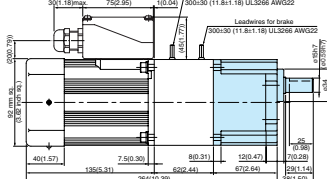

* Diameter of applicable cable to be ø8(ø0.31) to ø12(ø0.47).

Induction motor
Reversible motor
3-phase motor
Electromagnetic brake motor
Variable speed induction motor
Variable speed reversible motor
Variable speed single-phase motor
Variable speed unit motor
C&B motor
2-pole round shaft
Gear head
Gear head -high (U.S.A.)

C&B motor (3-phase motor leadwire)

Gear head combination dimensions

Scale: 1/4, Unit: mm (inch)

80 mm sq. (3.15 inch sq.) 25 W
M8MX25H4Y + MX8G□H

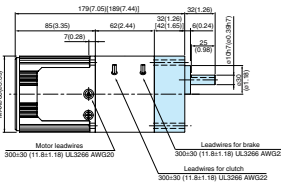

* Figures in [] represent the dimensions of MX8G□H (1/30 or larger reduction ratio).

90 mm sq. (3.54 inch sq.) 40 W
M9MX40H4Y + MX9G□H

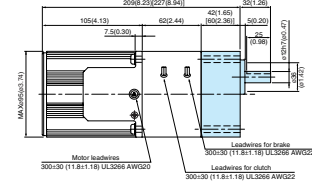

* Figures in [] represent the dimensions of MX9G□H (1/20 or larger reduction ratio).

90 mm sq. (3.54 inch sq.) 60 W
M9MZ60H4Y + MY9G□H

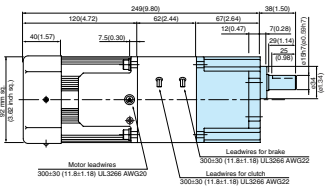

90 mm sq. (3.54 inch sq.) 90 W
M9MZ90H4Y + MY9G□H

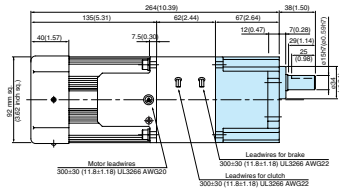

* Please read your User's manual carefully so that you will understand the operation and safety precautions before attempting to operate the system.

Features B-342 System configuration B-343 Coding system B-343 Model list B-350

C&B motor (3-phase motor sealed connector)

Gear head combination dimensions

Scale: 1/4, Unit: mm (inch)

80 mm sq. (3.15 inch sq.) 25 W
M8MX25HK4Y + MX8G□H

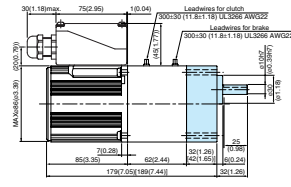

* Figures in [] represent the dimensions of MX8G□H (1/30 or larger reduction ratio).
* Diameter of applicable cabtry cable to be ø8(ø0.31) to ø12(ø0.47).

90 mm sq. (3.54 inch sq.) 40 W
M9MX40HK4Y + MX9G□H

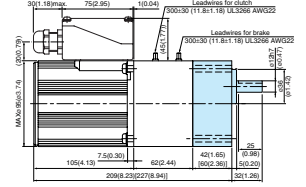

* Figures in [] represent the dimensions of MX9G□H (1/20 or larger reduction ratio).
* Diameter of applicable cabtry cable to be ø8(ø0.31) to ø12(ø0.47).

90 mm sq. (3.54 inch sq.) 60 W
M9MZ60HK4Y + MY9G□H

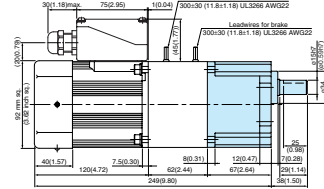

* Diameter of applicable cabtry cable to be ø8(ø0.31) to ø12(ø0.47).

90 mm sq. (3.54 inch sq.) 90 W
M9MZ90HK4Y + MY9G□H

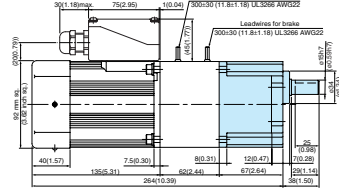

* Diameter of applicable cabtry cable to be ø8(ø0.31) to ø12(ø0.47).

(Note) Because the dimensions may be subject to change, also check the determine dimensions if the gear head is to be used for design.

Specifications B-352 to B-399 Controls C-4 Option D-2

Induction motor
Reversible motor
3-phase motor
Electromagnetic brake motor
Variable speed induction motor
Variable speed reversible motor
Variable speed synchronous motor
Variable speed unit motor
C&B motor
2-pole round shaft
Gear head
Gear head -high (U.S.A.)

