

<FEATURES>

This IC is 1 chip driver IC for spindle motor and 4 channel actuators. All of the motor and actuator of optical disk drive system (CD-ROM etc.) can be driven by only this IC.
 This IC has a direct PWM control system for Spindle and Slide channels drive due to reducing IC power dissipation.
 This IC has three voltage supply terminals (for Spindle, Slide/Loading and Focus/Tracking), and these voltage supply can be set separately.
 Further more this IC has FG amplifier, thermal shut down circuit, standby circuit, channel select function, reverse rotation detect circuit.

<APPLICATION>

CD-ROM, DVD, DVD-ROM, DVD-RAM ,
 Optical disc related system,etc

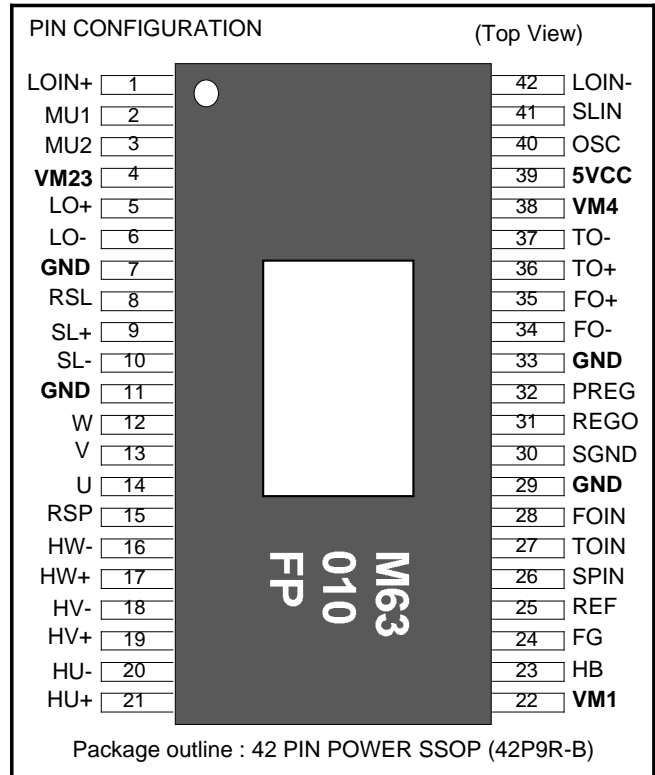

<BLOCK DIAGRAM>

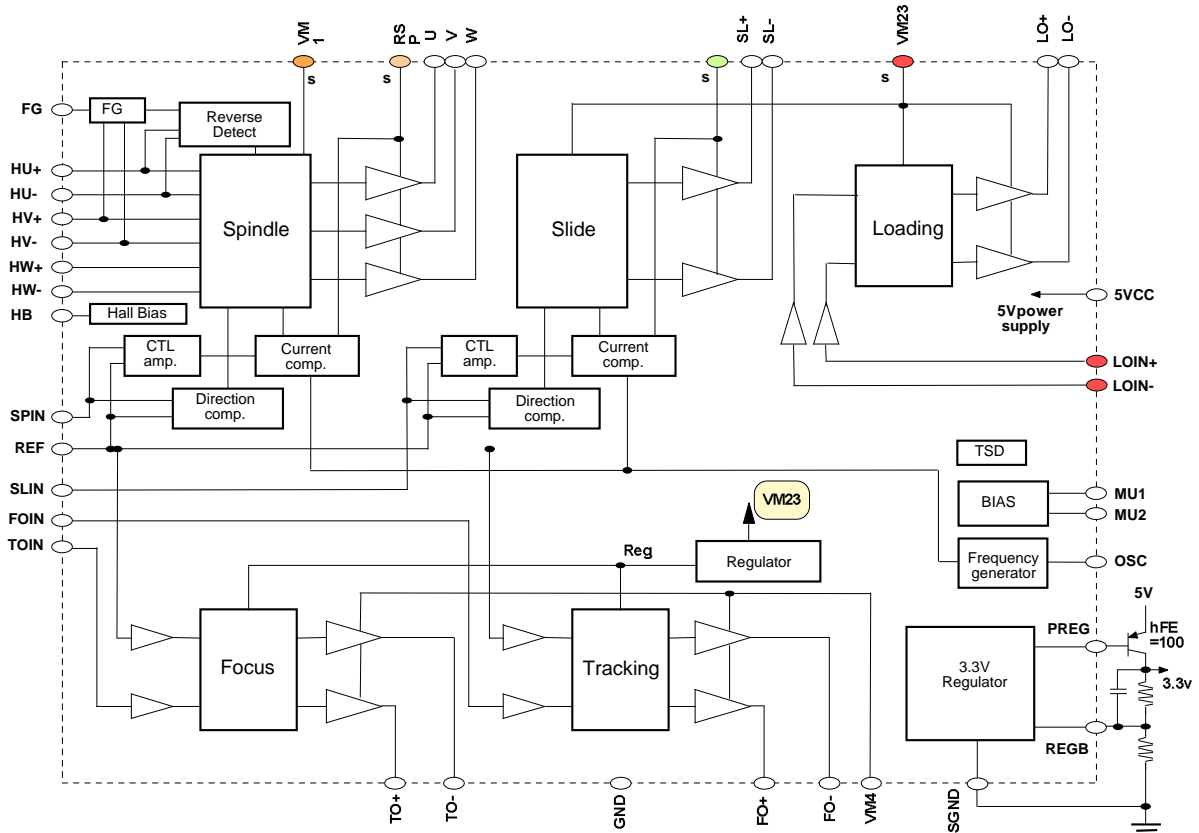

<PIN FUNCTION>

TERMINAL	SYMBOL	TERMINAL FUNCTION	TERMINAL	SYMBOL	TERMINAL FUNCTION
1	LOIN+	Loading control input(+)	42	LOIN-	Loading control input(-)
2	MU1	mute 1	41	SLIN	Slide control voltage input
3	MU2	mute 2	40	OSC	PWM carrier oscilation set
4	VM23	Motor Power Suppry 3 (for Slide/Loading)	39	5VCC	5V Power Supply
5	LO+	Loading non-inverted output	38	VM4	Motor Power Suppry 4 (for FS and TS)
6	LO-	Loading inverted output	37	TO-	Tracking inverted output
7	GND	GND	36	TO+	Tracking non-inverted output
8	RSL	Slide current sense	35	FO+	Focus non-inverted output
9	SL+	Slide non-inverted output	34	FO-	Focus inverted output
10	SL-	Slide inverted output	33	GND	GND
11	GND	GND	32	PREG	Regulator output
12	W	Motor drive output W	31	REGO	Regulator reference voltage output
13	V	Motor drive output V	30	SGND	Regulator GND
14	U	Motor drive output U	29	GND	GND
15	RSP	Spindle current sensie	28	FOIN	Focus control voltage input
16	HW-	HW- sensor amp. input	27	TOIN	Tracking control voltage input
17	HW+	HW+ sensor amp. input	26	SPIN	Spindle control voltage input
18	HV-	HV- sensor amp. input	25	REF	Reference voltage input
19	HV+	HV+ sensor amp. input	24	FG	Frequency generator output
20	HU-	HU- sensor amp. input	23	HB	Bias for Hall Sensor
21	HU+	HU+ sensor amp. input	22	VM1	Motor Power Suppry 1 (for Spindle)

<ABSOLUTE MAXIMUM RATING> (Ta=25°C)

SYMBOL	PARAMETER	CONDITIONS	RATING	Unit
5VCC	5V power supply		7	V
VM1	Motor power supply 1	Spindle power supply	15	V
VM23	Motor power supply 23	Slide and Loading power supply	15	V
VM4	Motor power supply 4	Focus and Tracking power supply	15	V
IoA	Motor Output Current A	Focus, Tracking and Loading output current *note 1	1.0	A
IoB	Motor Output Current B	Spindle and Slide output current *note 1	1.2	A
Vin	Maximum input voltage of terminals	MU1, MU2, Hw-, Hw+, Hv-, Hv+, Hu-, Hu+, REF, SPIN, TOIN, FOIN, OSC, SLIN, LOIN-, LOIN+	0 to 5VCC	V
Pt	Power dissipation	Free Air and on the grass epoxy board	2.6	W
K	Thermal derating	Free Air and on the grass epoxy board	20.8	mW / °C
Tj	Junction temperature		150	°C
Topr	Operating temperature		-20 to +75	°C
Tstg	Storage temperature		-40 to +150	°C

*note1 ; The ICs must be operated within the Pt (power dissipation) or the area of safety operation

The spindle and slide output terminal is needed external shottky diode between each output and GND when it is used above 0.6A. Discription(IoA) is case of with external shottky diode.

<RECOMMENDED OPERATING CONDITIONS> (Ta=25°C)

SYMBOL	PARAMETER	LIMITS			Unit
		minimum	typical	maximum	
VM1	VM1 power supply(for Spindle)	6	12	13.2	V
VM23	VM23 power supply(for Slide and Loading)	6	12	13.2	V
VM4	VM4 power supply(for Focus and Tracking)	4.5	5	13.2	V
IoA	Spindle and Slide Output Current *note2	—	0.5	1.0	A
IoB	Focus, Tracking and Loading Output Current	—	0.5	0.8	A
Fosc	Motor power supply 2	30	—	120	KHz

*note2

The spindle and slide output terminal is needed external shottky diode between each output and GND when it is used above 0.6A. Discription(IoA) is case of with external shottky diode.

[THERMAL DERATING]

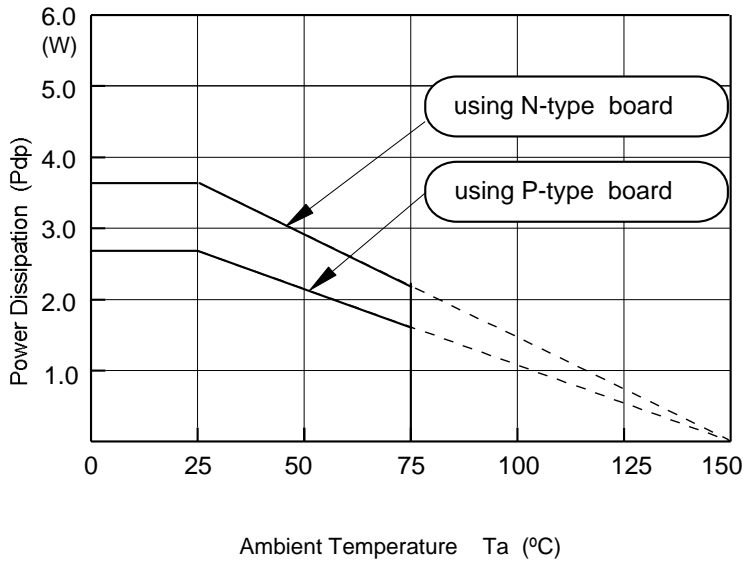

This IC's package is POWER-SSOP, so improving the board on which the IC is mounted enables a large power dissipation without a heat sink.

For example, using an 1 layer glass epoxy resin board, the IC's power dissipation is 2.6W at least. And it comes to 3.6W by using an improved 2 layer board.

The information of the N, P type board is shown in attached.

[ELECTRICAL CHARACTERISTICS]

Common

(Ta=25°C, 5VCC=VM4=5V, VM1=VM23=12V unless otherwise noted.)

SYMBOL	PARAMETER	CONDITIONS	LIMITS			Unit
			MIN	TYP	MAX	
Icc1	Supply current	5VCC, VM1, VM23, VM4 current	—	60	78	mA
Icc2	Sleep current	5VCC, VM1, VM23, VM4 current under Sleep (MU1 = MU2 = 0V).	—	0	30	μA
Fosc	PWM carrier frequency	OSC : with 180pF	—	110	—	KHz
Vreg	3.3V regulator output voltage	with -300mA load (Reference to application circuit)	3.2	3.3	3.4	V
VinREF	REF input voltage range		1.0	—	3.3	V
IinREF	REF input voltage range	VREF=1.65V	-10	—	+10	μA
VMULO	MUTE terminal low voltage	MU1, MU2	—	—	0.8	V
VMUHI	MUTE terminal high voltage	MU1, MU2	3.0	—	—	V
IMU	Mute terminal input current	MU1, MU2 at 5V input voltage	—	—	500	μA

[ELECTRICAL CHARACTERISTICS]

Spindle

(Ta=25°C, 5VCC=VM4=5V, VM1=VM23=12V unless otherwise noted.)

SYMBOL	PARAMETER	CONDITIONS	LIMITS			Unit
			MIN	TYP	MAX	
Vdyc1	Dynamic range of output	Io=0.5 [A]	10.3	10.8	—	V
Vdead1-	Control voltage dead zone 1	SPIN<REF [REVERSE]	-80	-40	0	mV
Vdead1+		REF<SPIN [FORWARD]	0	+40	+80	mV
Vin1	Control voltage input range 1	SPIN	0	—	5	V
Gvo1	Control gain 1	Gio1=Gvo1/ Rs [A/V]	0.85	1.0	1.15	V/V
Vlim1F	Control limit 1F	Ilim1F=Vlim1F/ Rs [A] [FORWARD]	0.4	0.5	0.6	V
Vlim1R	Control limit 1R	Ilim1R=Vlim1R/ Rs [A] [REVERSE]	0.27	0.34	0.41	V
VHcom	Hall sensor amp. common mode input range	Hu+,Hu-,Hv+,Hv-,Hw+ ,Hw-	1.3	—	3.7	V
VHmin	Hall sensor amp input signal level	Hu+,Hu-,Hv+,Hv-,Hw+ ,Hw-	60	—	—	mVp-p
VHB	HB output voltage	at Load current (IHB)=10mA	0.6	0.85	1.2	V
IHB	HB terminal sink current	MU1=MU2=0V or MU1=MU2=5V or MU1=5V/MU2=0V	—	—	30	mA

Slide

(Ta=25°C, 5VCC=VM4=5V, VM1=VM23=12V unless otherwise noted.)

SYMBOL	PARAMETER	CONDITIONS	LIMITS			Unit	
			MIN	TYP	MAX		
Vdyc2	Dynamic range of output	Io=0.5 [A]	at VM23=5[V]	3.3	3.8	—	V
			at VM23=12[V]	10.3	10.8	—	
Vdead2-	Control voltage dead zone 2	SLIN < REF	-60	-30	0	mV	
Vdead2+		REF < SLIN	0	+30	+60	mV	
Vin2	Control voltage input range 2	SLIN	0	—	5	V	
Gvo2	Control gain 2	Gio2=Gvo2/ Rs [A/V]	0.85	1.0	1.15	V/V	
Vlim2	Control limit 2	Ilim2=Vlim2/ Rs [A]	0.43	0.5	0.58	V	
Tdon	Output turn-on delay		—	1.0	2.0	µsec	
Tdoff	Output turn-off delay		—	2.0	3.5	µsec	
Tdsw	Output switching delay		—	3.0	5.0	µsec	
Ileak	Output leak current	MU1=MU2=5v, MU1=MU2=0v	-100	—	100	µA	

[ELECTRICAL CHARACTERISTICS]

Loading

(Ta=25°C, 5VCC=VM4=5V, VM1=VM23=12V unless otherwise noted.)

SYMBOL	PARAMETER	CONDITIONS	LIMITS			Unit	
			MIN	TYP	MAX		
Vdyc3	Dynamic range of output	Io=0.5[A]	VM23=5[V]	3.3	3.8	—	V
			VM23=12[V]	10.3	10.8	—	
Vin3	Control voltage input range3	LOIN+, LOIN-	0	—	5	V	
Gvo3	Control gain 3	$\frac{(LO+) - (LO-)}{(LOIN+) - (LOIN-)}$	16.6	18	19.3	dB	
Voff1	Output offset voltage	(LO+) - (LO-) at LOIN+=LOIN-=5V	-60	0	+60	mV	

Focus / Tracking

(Ta=25°C, 5VCC=VM4=5V, VM1=VM23=12V unless otherwise noted.)

SYMBOL	PARAMETER	CONDITIONS	LIMITS			Unit	
			MIN	TYP	MAX		
Vdyc4	Dynamic range of output	Io=0.5[A] VM1=12[V]	VM4=5[V]	3.8	4.2	—	V
			VM4=12[V]	7.1	7.6	—	
Vin4	Control voltage input range4	FOIN, TOIN	0	—	5	V	
Gvo4	Control gain 4	$\frac{(FO+) - (FO-)}{FOIN-REF}$ $\frac{(TO+) - (TO-)}{TOIN-REF}$	12.5	14	15.2	dB	
Voff2	Output offset voltage	(FO+) - (FO-) at REF=FOIN=1.65V (TO+) - (TO-) at REF=TOIN=1.65V	-35	0	+35	mV	

[THERMAL CHARACTERISTICS]

SYMBOL	PARAMETER	FUNCTION START TEMPERATURE OF IC			FUNCTION STOP TEMPERATURE OF IC			Unit
		MIN	TYP	MAX	MIN	TYP	MAX	
TSD	Thermal Shut Down	—	160	—	—	130	—	°C

Channel select function

	Logic control		Drive channel					
	MU1	MU2	Loading	Slide	Focus	Tracking	Spindle	Regulator-
SELECT4	H	H	On	On	On	On	On	On
SELECT3	L	H	On	Off	Off	Off	Off	Off
SELECT2	H	L	On	On	Off	Off	Off	On
SELECT1	L	L	Off	Off	Off	Off	Off	Off

This IC has two MUTE terminal (MU1 and MU2).

It is possible to control ON / OFF of each channel by external logic inputs.

It has four kinds of function for channel select. In case of SELECT1, the bias of all circuit becomes OFF.

Therefore, this mode is available in order to reduce the power dissipation when the waiting mode.

In case of SELECT2, the bias of the loading, the slide and the regulator amplifier circuit becomes ON.

In case of SELECT3, it is possible to make OFF the loading channel only.

In case of SELECT4, the bias of all channel becomes ON.

Regard with making OFF the loading channel in case of SELECT2, SELECT3 and SELECT4, please refer to [Loading channel].

Loading channel

The loading channel is the circuit of BTL voltage drive. This circuit has the referential input. Output swing is determined with $V_{in} \times 8$. Also, it is possible for this channel to use for the slide motor, the focus coil and the tracking coil.

The input terminal is high impedance. It is possible to do variable a gain by external resistor.

The output becomes high impedance in case of both input voltage becomes under 0.7 volts. It is possible for the input terminal to operate from 0 volts. The following table and diagram show an application in case of two MCU port and one MCU port for the loading motor. In case of one MCU port, if use three state port, it is possible for this channel to have the stop function.

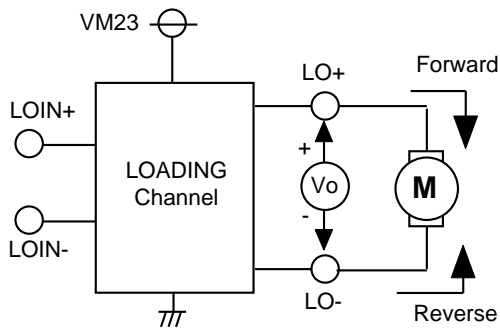

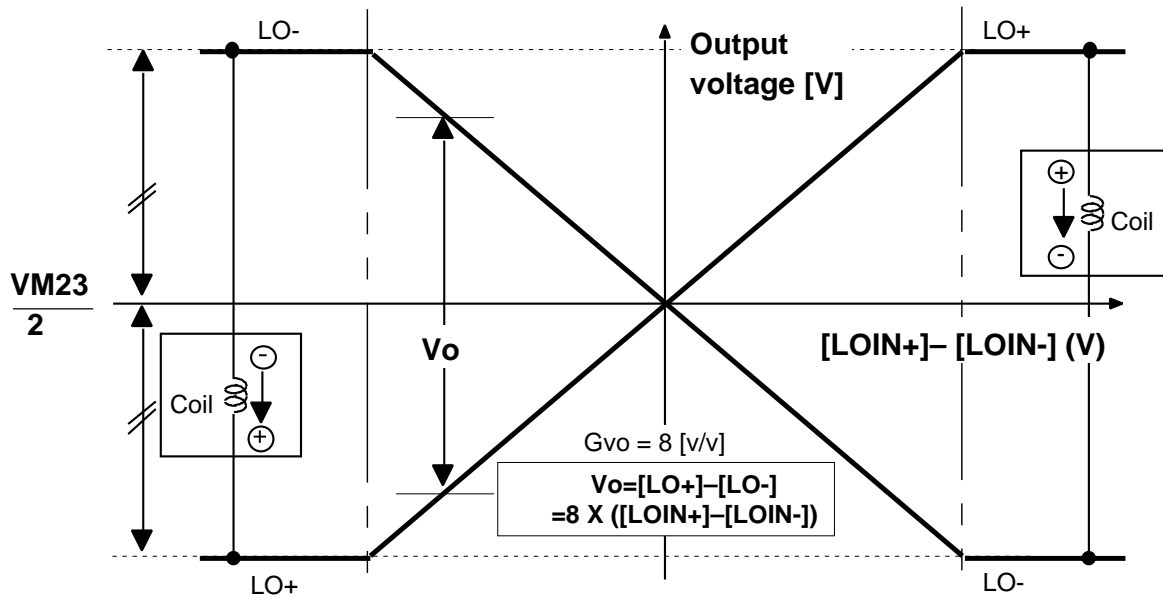

application.1 (MCU:Two port H/L control)

Logic control		Situation of loading channel	Output voltage swing
P1	P2		
5V	5V	Short brake --> Stop	$V_o = 0 [V]$
0	5V	Reverse rotation	$V_o = -8 \times 5 \times R1 / (R1 + 2 \times R2)$
5V	0	Forward rotation	$V_o = 8 \times 5 \times R1 / (R1 + 2 \times R2)$
0	0	Off [High impedance output]	Off

application.2 (MCU:One port H/Z/L control)

Logic control P1	Situation of loading channel	Output voltage swing
5v	Forward rotation	$V_o = \frac{2.5[V] \times 8 \times R2}{(R1/2) + R2 + R3}$
Z (Hi impedance)	Short brake --> Stop	$V_o = 0 [V]$
0	Reverse rotation	$V_o = \frac{-2.5[V] \times 8 \times R2}{(R1/2) + R2 + R3}$

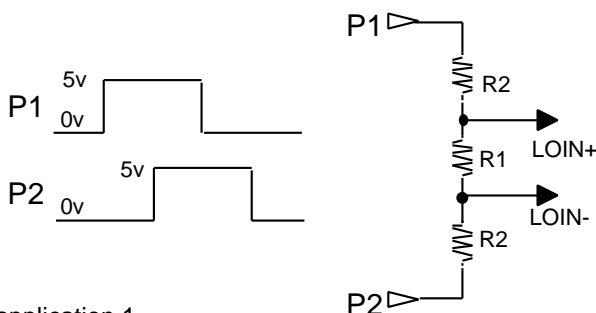

application.1
 (Two port H/L control)

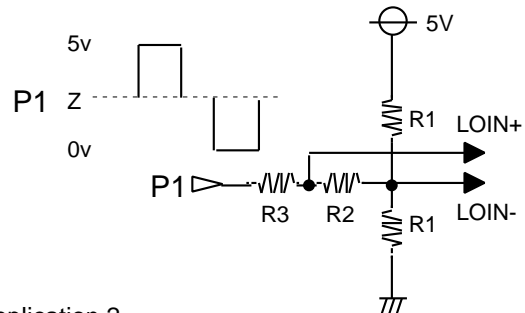

application.2
 (One port H/Z/L control)

SPINDLE channel

The relationship between the differential voltage between SPIN and REF and the torque is shown in right Figure. The voltage gain[Gvo] is 1.0 [V/V]. The current gain[Gio] is 2.0A/V (at sensing resistor : 0.5 ohm, and R1= ,R2=0ohm) in forward torque directions, and the dead zone is from 0mV to 80mV (at R1= ,R2=0ohm) .

The coil current gain under the reverse torque is the same with in forward torque directions. And the limitation function gets on when the differential voltage of VM1(12V) to RSP is 0.5V at forward and 0.3V at reverse. Therefore current-gain-control and current-limit of this IC is determined with sensing resistor value, and more detail control can be determined with setting a gain-resistor outer this IC as below.

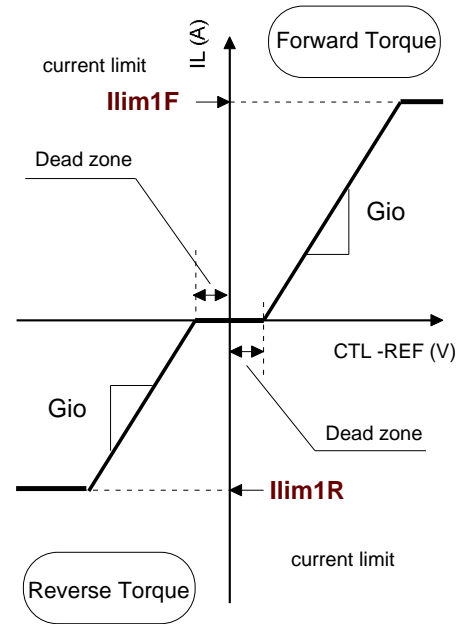

The example of current-gain and current-limit of SPINDLE.

Rs [Ω]	Ilim1F [A]	Ilim1R [A]	Gio* [A/V]		
			R1= R2=0 ohm	R1=R2	R1=2•R2
0.50	1.00	0.68	2.00	1.00	0.66
0.75	0.66	0.45	1.33	0.66	0.44
1.00	0.50	0.34	1.00	0.50	0.33

$$G_{io}^* = R1 / [(R1+R2) \cdot R_s] \text{ [A/V]}$$

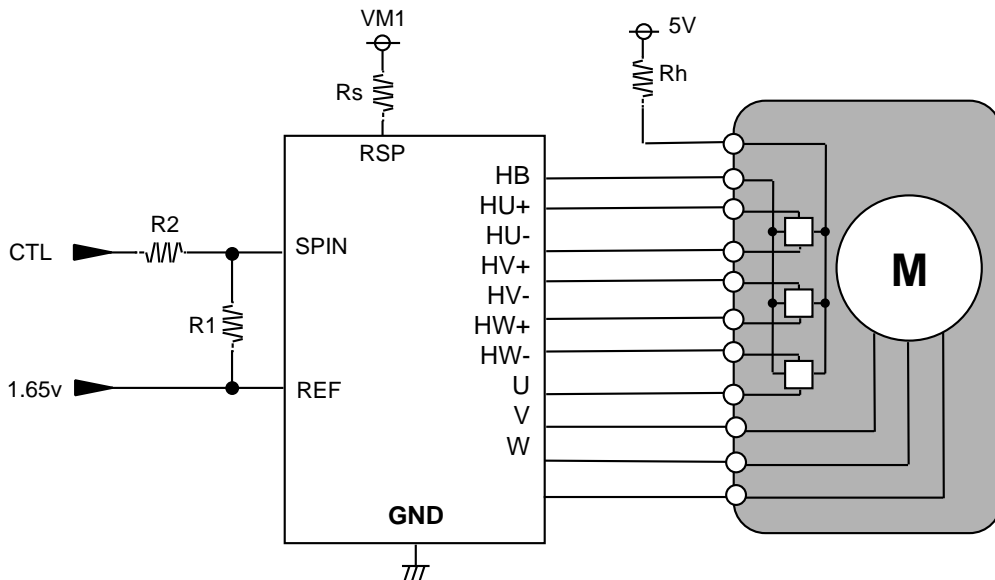

SLIDE channel

The relationship between the differential voltage between SLIN and REF and the torque is shown in right Figure. The voltage gain[Gvo] is 1.0 [V/V]. The current gain is 2.0[A/V] (at sensing resistor : 0.5 ohm and R1= ,R2=0ohm) in forward torque directions, and the dead zone is from 0mV to 60mV (at R1= ,R2=0ohm).

The coil current gain under the reverse torque is the same with in forward torque directions. And the limitation function gets on when the differential voltage of VM23(12V) to RSL is 0.5V. Therefore current-gain-control and current-limit of this IC is determined with sensing resistor value.

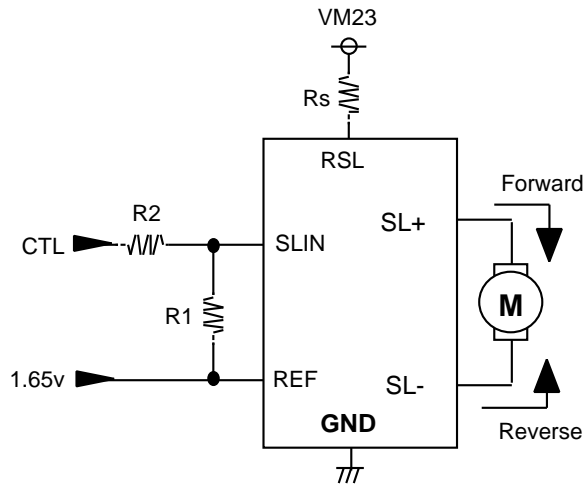
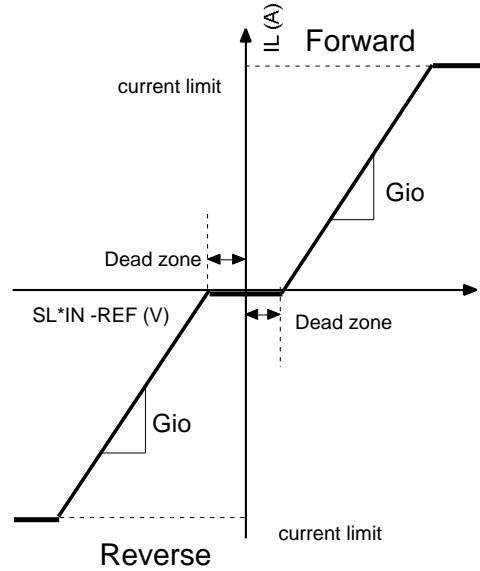

The example of current-gain and current-limit of SLIDE.

Rs [Ω]	Ilim [A]	Gio* [A/V]		
		R1= R2=0 ohm	R1=R2	R1=2•R2
0.50	1.00	2.00	1.00	0.66
0.75	0.66	1.33	0.66	0.44
1.00	0.50	1.00	0.50	0.33

$$G_{io}^* = R_1 / [(R_1 + R_2) \cdot R_s] \text{ [A/V]}$$

FOCUS / TRACKING channel

The focus and tracking channel is the voltage control drive using BTL .

The focus and tracking is the same composition.

The relationship between the differential voltage between FOIN and REF and the output voltage is shown in below Figure.

The voltage gain [Gvo] is 5.0 [V/V].

The maximum range of output swing is limited around 7.5 volts, in case of VM4 is above 10 volts.

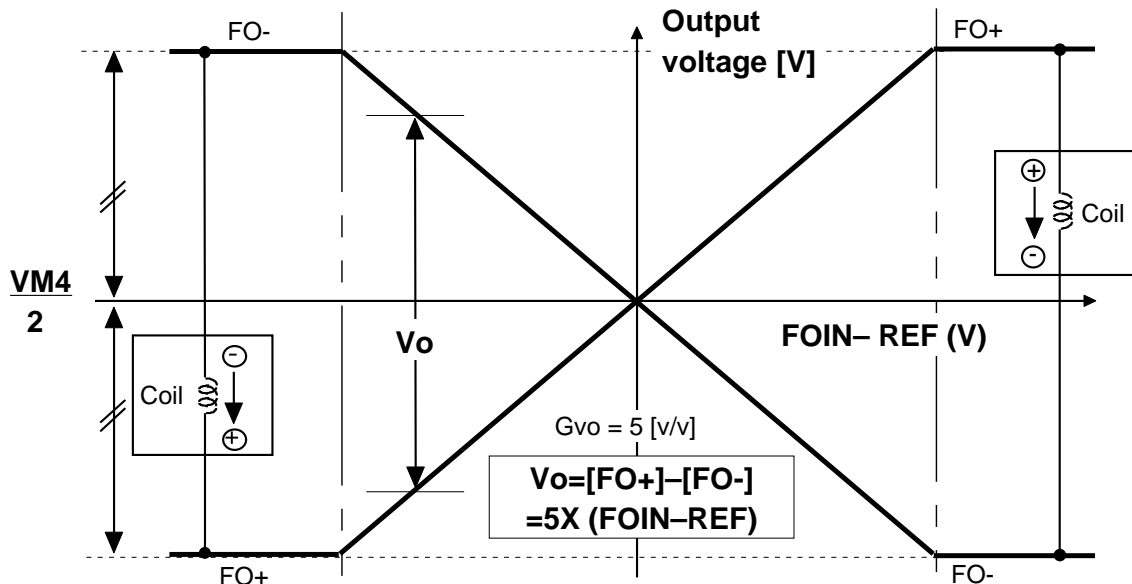
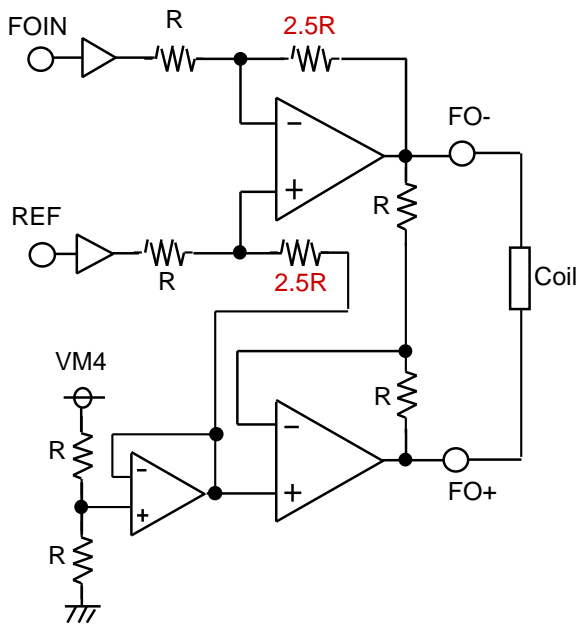

Direct PWM operation

The spindle and the slide channel is controlled by the direct PWM control.
 Also, built-in the current limit circuit. This IC controls the motor current directly.

FORWARD Current path timing 1.

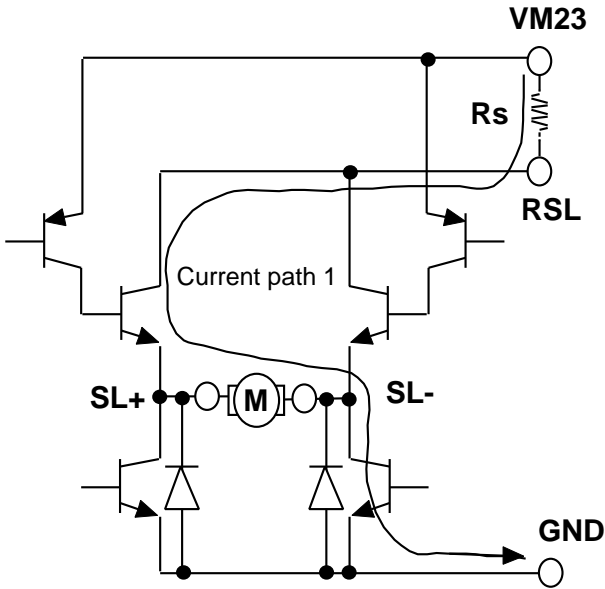

FORWARD Current path timing 2.

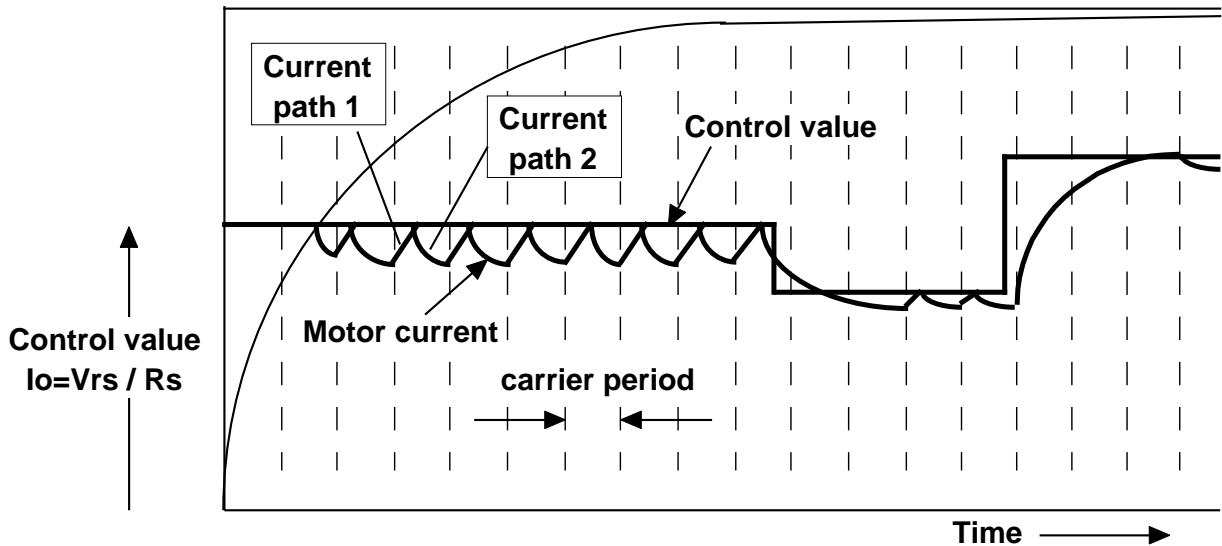
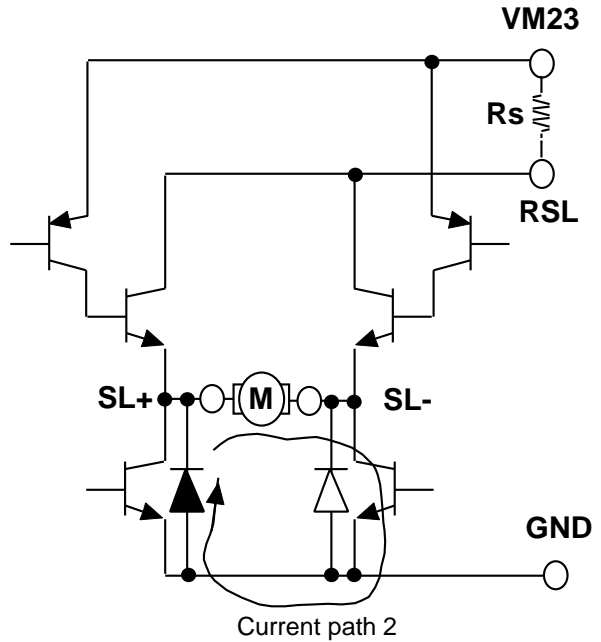

PWM carrier frequency setting

PWM carrier frequency is decided by charging and discharging the capacitor that is connected to OSC terminal outer IC. Examination of the relationship the capacitor connected to OSC terminal and PWM carrier frequency is given in following table.

Capacitor [pF]	330	220	180	130	110
Carrier Frequency [KHz]	65	90	110	140	160

*note) This PWM carrier frequency is TYP value.

The relationship between hall-amplifier-input and output-current-commutation at SPINDLE DRIVE

The relationship between the hall elements and the motor output current is shown in bellow Figure.

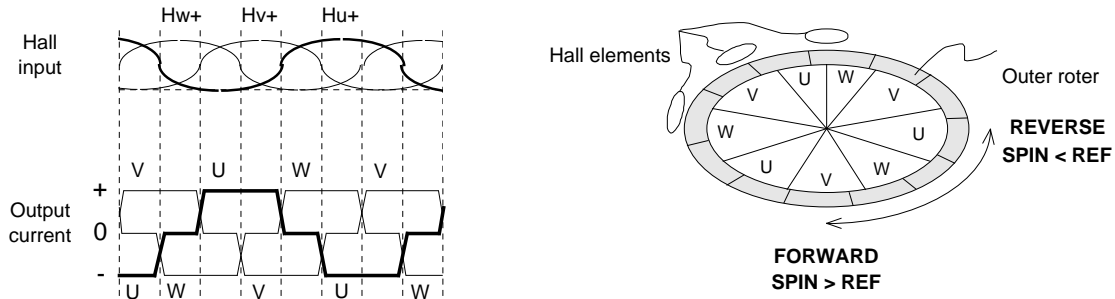

FG function at SPINDLE DRIVE

The FG terminal outputs the square pulse signal synchronizing with the Hall inputs [Hv+, Hv-] timing. And, the FG terminal is open-collector output.

Phase delay circuit at SLIDE

Phase delay circuit is built in the IC to detect an output spike current, when the motor current direction is switching. In switching the motor current direction, Phase delay circuit switch-off all output transistor of H-bridge for 3μsec.

Output current setting at SLIDE

In this IC, since output transistor is NPN-type transistor, motor coil current (Io) is larger than sensing resistance current about 20mA (TYP.) according to base current of output transistor. Therefore please design output current with consisting these base current.

I/O circuit

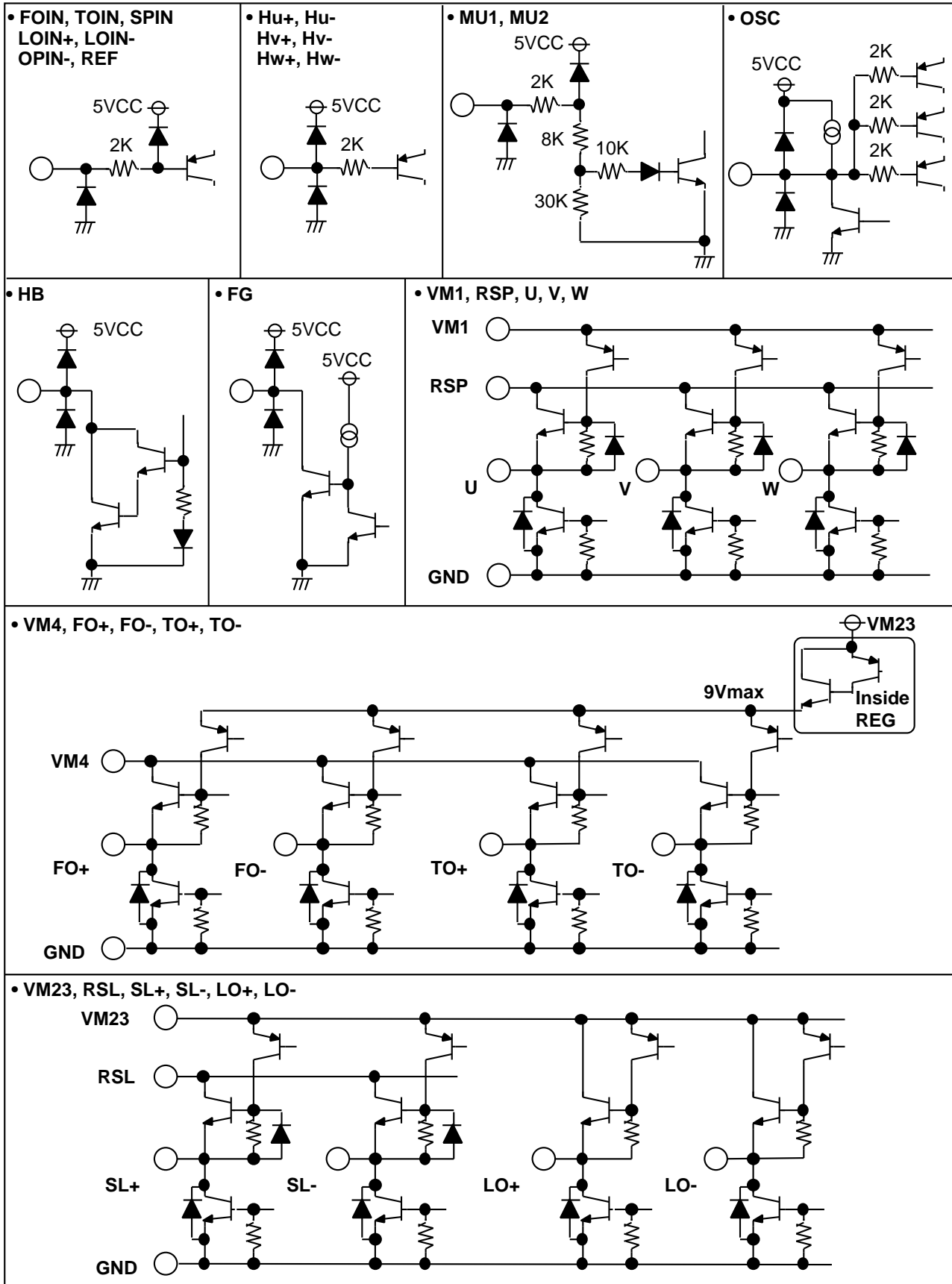

[The boards for thermal derating evaluation]

Board material
Glass-epoxy FR-4

Size
70 x 70mm

thickness
t=1.6mm

1 and 2 layers

material : copper

thickness
:t=18 μ m

1st layer [TOP view]

2nd layer [BACK view]

N-type board
[2 layer]

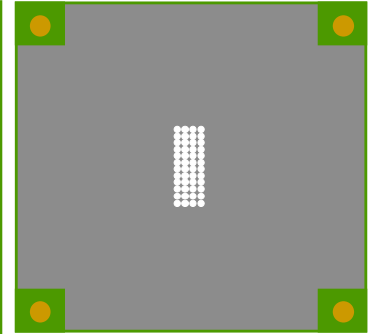
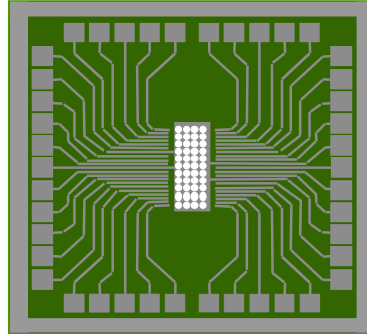

O-type board
[2 layer]

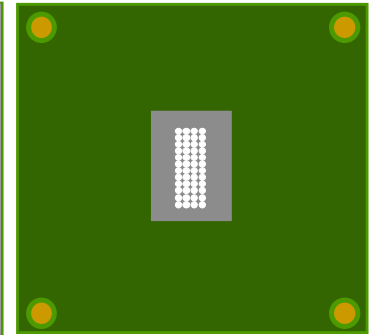
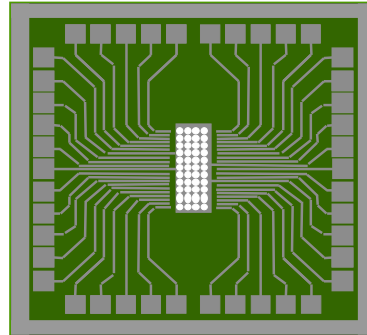

P-type board
[1 layer]

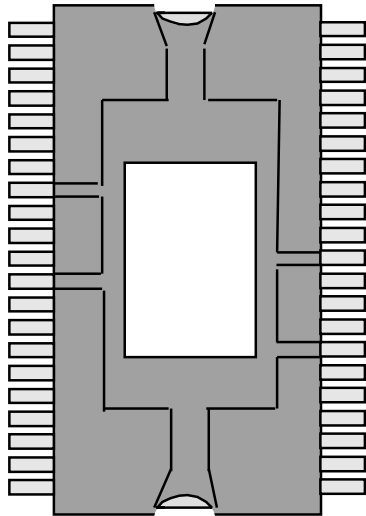
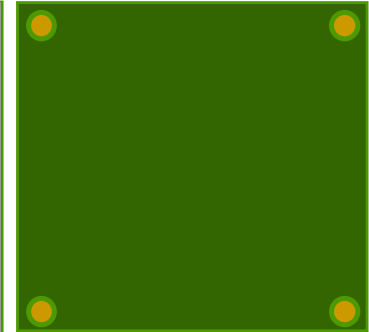
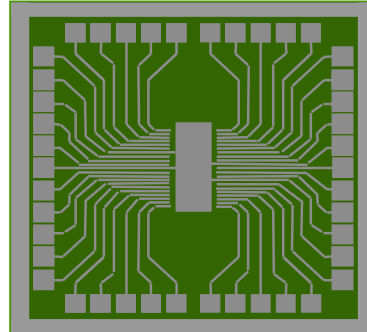

POWER-SSOP 42P9R-B

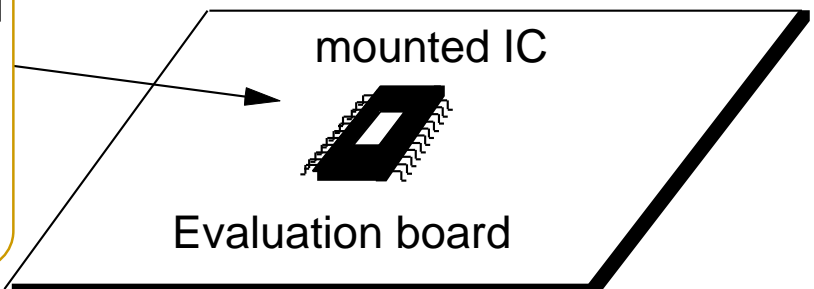
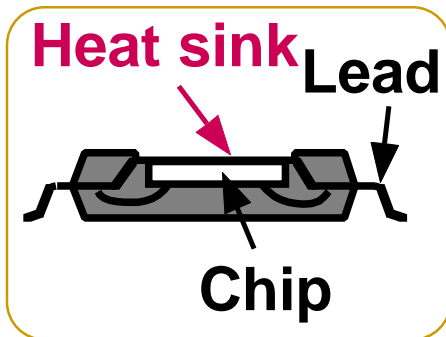

[APPLICATION CIRCUIT no.1]

