

FEATURES

- * 0.35-inch (9-mm) DIGIT HEIGHT
- * CONTINUOUS UNIFORM SEGMENTS
- * LOW POWER REQUIREMENT
- * EXCELLENT CHARACTERS APPEARANCE
- * HIGH BRIGHTNESS & HIGH CONTRAST
- * WIDE VIEWING ANGLE
- * SOLID STATE RELIABILITY
- * CATEGORIZED FOR LUMINOUS INTENSITY

DESCRIPTION

The LTC-3883G is a 0.35 inch (9 mm) digit height quadruple digit seven-segment display. This device uses green LED chips (GaP on GaP substrate) .The display has black face and white segments.

DEVICE

PART NO.	DESCRIPTION
Green	Common Anode
LTC-3883G	

PACKAGE DIMENSIONS

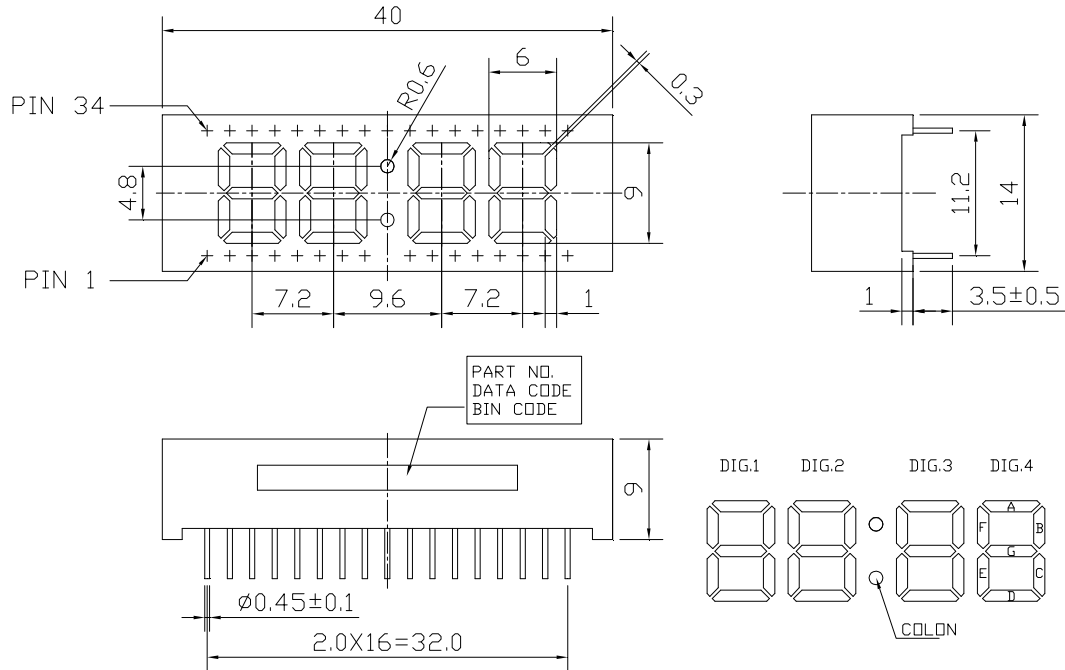

NOTE :1. All dimensions are in millimeters, tolerances are ± 0.25 mm unless otherwise noted.

NOTES:1. All dimensions are in millimeters. Tolerances are ± 0.25 -mm (0.01“) unless otherwise noted

INTERNAL CIRCUIT DIAGRAM

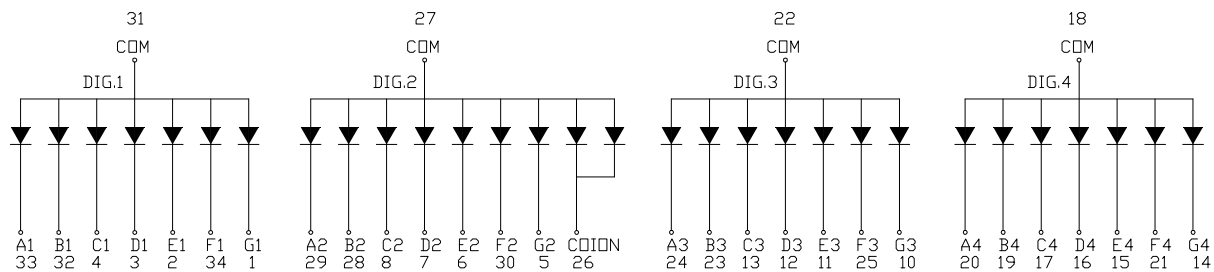

PIN CONNECTION

1	CATHODE G1
2	CATHODE E1
3	CATHODE D1
4	CATHODE C1
5	CATHODE G2
6	CATHODE E2
7	CATHODE D2
8	CATHODE C2
9	NP
10	CATHODE G3
11	CATHODE E3
12	CATHODE D3
13	CATHODE C3
14	CATHODE G4
15	CATHODE E4
16	CATHODE D4
17	CATHODE C4
18	COMMEN ANODE DIG.4
19	CATHODE B4
20	CATHODE A4
21	CATHODE F4
22	COMMEN ANODE DIG.3
23	CATHODE B3

24	CATHODE A3
25	CATHODE F3
26	CATHODE COLON
27	COMMEN ANODE DIG.2
28	CATHODE B2
29	CATHODE A2
30	CATHODE F2
31	COMMEN ANODE DIG.1
32	CATHODE B1
33	CATHODE A1
34	CATHODE F1

ABSOLUTE MAXIMUM RATING AT Ta=25°C

PARAMETER	MAXIMUM RATING	UNIT
Power Dissipation Per Segment	75	mW
Peak Forward Current Per Segment (Frequency 1Khz, 10% duty cycle)	100	mA
Continuous Forward Current Per Segment	25	mA
Derating Linear From 25°C Per Segment	0.33	mA/°C
Reverse Voltage Per Segment	5	V
Operating Temperature Range	-35°C to +85°C	
Storage Temperature Range	-35°C to +85°C	
Solder Temperature 1/16 inch Below Seating Plane for 3 Seconds at 260°C		

ELECTRICAL / OPTICAL CHARACTERISTICS AT T a=25°C

PARAMETER	SYMBOL	MIN.	TYP.	MAX.	UNIT	TEST CONDITION
Average Luminous Intensity	I _v	800	2000		μcd	I _F =10mA
Peak Emission Wavelength	λ _p		565		nm	I _F =20mA
Spectral Line Half-Width	Δλ		30		nm	I _F =20mA
Dominant Wavelength	λ _d		569		nm	I _F =20mA
Forward Voltage Per Segment	V _F		2.1	2.6	V	I _F =20mA
Reverse Current Per Segment	I _R			100	μA	V _R =5V
Luminous Intensity Matching Ratio (Similar Light Area)	I _{v-m}			2:1		I _F =10mA

Note: Luminous intensity is measured with a light sensor and filter combination that approximates the CIE (Commision Internationale De L'Eclariage) eye-response curve.

TYPICAL ELECTRICAL / OPTICAL CHARACTERISTIC CURVES

(25°C Ambient Temperature Unless Otherwise Noted)

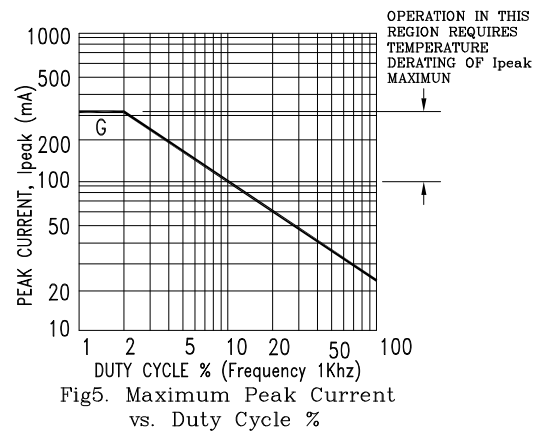
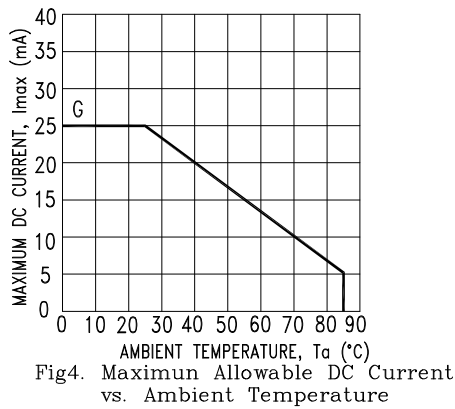
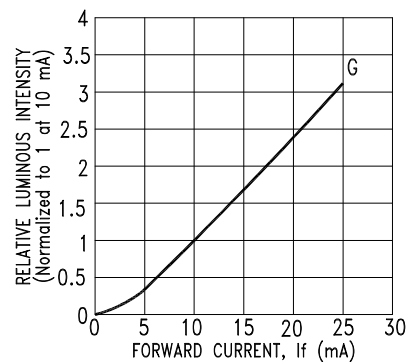
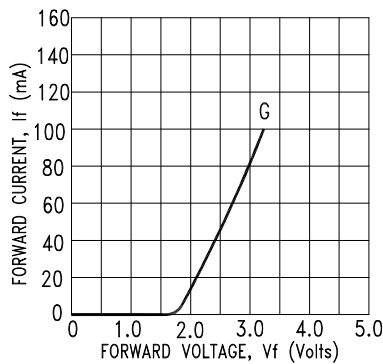
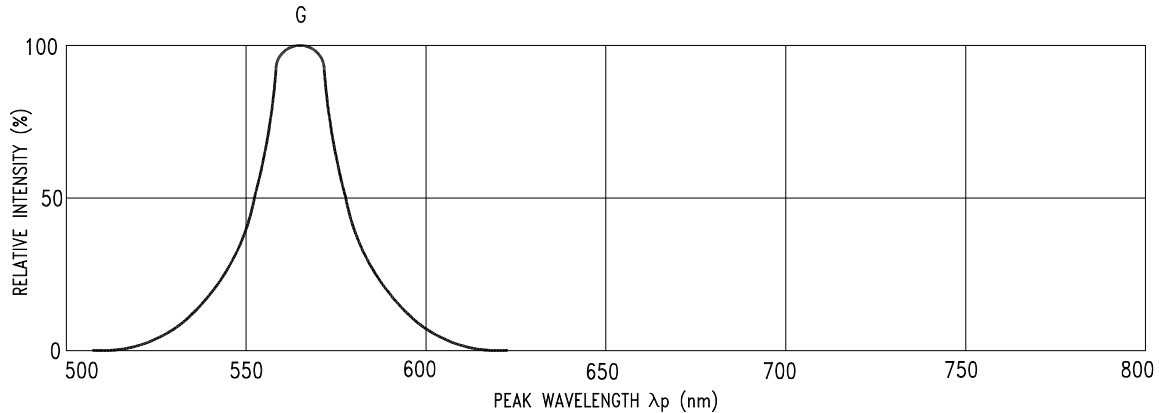

NOTE: G=GREEN.