

LED DISPLAY

LTC-561KF

DATA SHEET

Rev	Description	By
01	ORIGINAL (Refer to contour drawing Revision (-))	<u>PRAPHAN</u> <u>04/05/2006</u>
(Above data for PD and Customer tracking only)		
-	NPPR Received and Upload on OPNC	<u>PRAPHAN</u> <u>04/05/2006</u>
A	Change average Luminous Intensity Per Segment test condition from 1mA to 20mA	KITTISAK B. July 04/08

SPEC. NO.: DS30-2006-041

D A T E : July 04/08

REV. NO. : A

PAGE NO. : 0 OF 5

FEATURES

- * 0.56 inch (14.22 mm) DIGIT HEIGHT.
- * CONTINUOUS UNIFORM SEGMENTS.
- * LOW POWER REQUIREMENT.
- * EXCELLENT CHARACTERS APPEARANCE.
- * HIGH BRIGHTNESS & HIGH CONTRAST.
- * WIDE VIEWING ANGLE.
- * SOLID STATE RELIABILITY.
- * CATEGORIZED FOR LUMINOUS INTENSITY.
- * **LEAD-FREE PACKAGE (ACCORDING TO ROHS).**

DESCRIPTION

The LTC-561KF is a 0.56 inch (14.22 mm) digit height triple digit seven-segment display. This device AS-AllnGaP Yellow Orange LED chips (AllnGaP epi on GaAs substrate). The display has gray face and white segments.

DEVICE

PART NO.	DESCRIPTION
AllnGaP Yellow Orange	Multiplex Common Anode
LTC-561KF	Rt. Hand Decimal

PACKAGE DIMENSIONS

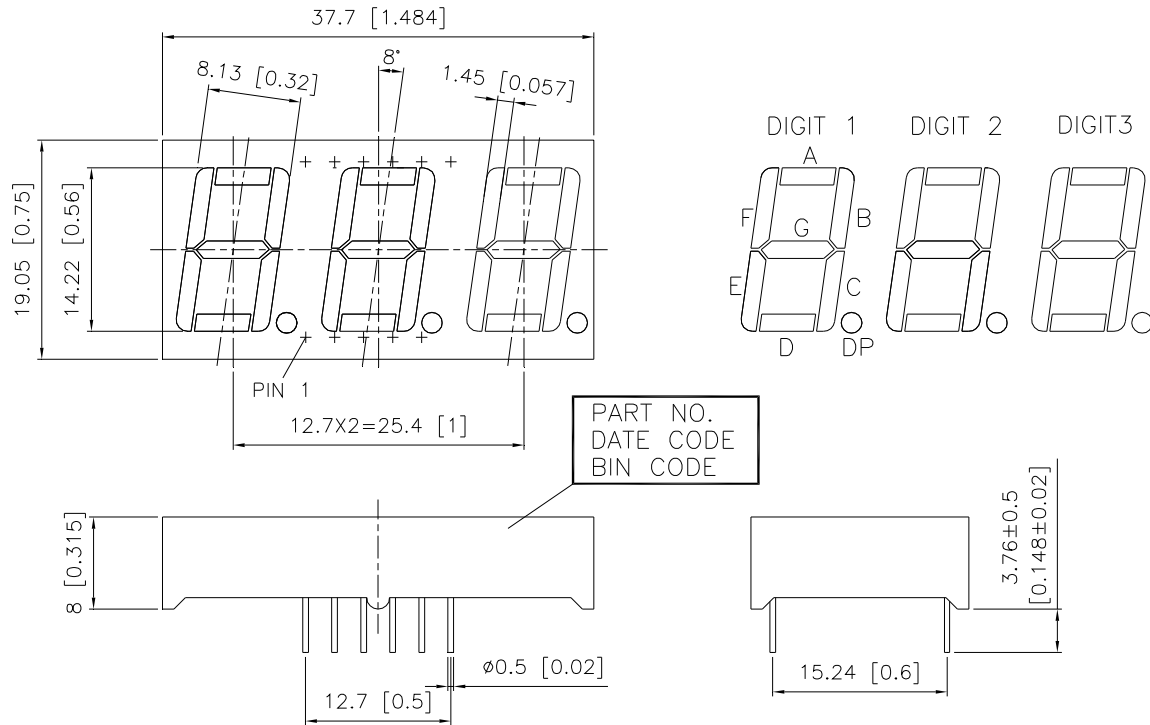

- NOTES: 1. All dimensions are in millimeters. Tolerances are ± 0.25 mm (0.01") unless otherwise noted.
 2. Pin tip's shift tolerance is ± 0.4 mm.

INTERNAL CIRCUIT DIAGRAM

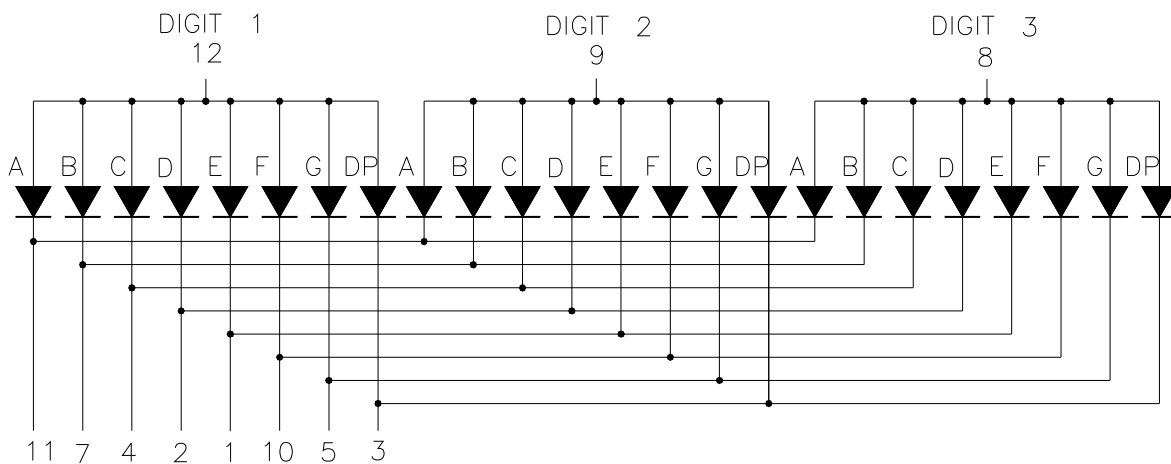

PIN CONNECTION

NO.	CONNECTION
1	CATHODE E
2	CATHODE D
3	CATHODE D.P.
4	CATHODE C
5	CATHODE G
6	NO CONNECTION
7	CATHODE B
8	COMMON ANODE, DIGIT 3
9	COMMON ANODE, DIGIT 2
10	CATHODE F
11	CATHODE A
12	COMMON ANODE , DIGIT 1

LITEON LITE-ON TECHNOLOGY CORPORATION

Property of Lite-On Only

ABSOLUTE MAXIMUM RATING AT Ta=25°C

PARAMETER	MAXIMUM RATING	UNIT
Power Dissipation Per Segment	70	mW
Peak Forward Current Per Segment (Frequency 1Khz, 10% duty cycle)	60	mA
Continuous Forward Current Per Segment	25	mA
Forward Current Derating from 25°C	0.28	mA/°C
Reverse Voltage Per Segment	5	V
Operating Temperature Range	-35°C to +105C	
Storage Temperature Range	-35°C to +105C	
Solder Temperature 1/16 inch Below Seating Plane for 3 Seconds at 260°C., or temperature of unit (during assembly) not over max. temperature rating above .		

ELECTRICAL / OPTICAL CHARACTERISTICS AT Ta=25°C

PARAMETER	SYMBOL	MIN	TYP	MAX	UNIT	TEST CONDITION
Average Luminous Intensity Per Segment	I _v	43750	70000		μcd	I _F = 20mA
Peak Emission Wavelength	λ _p		611		nm	I _F = 20mA
Spectral Line Half-Width	Δλ		17		nm	I _F = 20mA
Dominant Wavelength	λ _d		605		nm	I _F = 20mA
Forward Voltage Per Segment	V _F		2.05	2.6	V	I _F = 20mA
Reverse Current Per Segment	I _R			100	μA	V _R = 5V
Luminous Intensity Matching Ratio (Similar Light Area)	I _{v-m}			2 : 1		I _F = 20mA

Note: Luminous intensity is measured with a light sensor and filter combination that approximates the CIE (Commision Internationale De L'Eclairage) eye-response curve.

TYPICAL ELECTRICAL / OPTICAL CHARACTERISTIC CURVES

(25°C Ambient Temperature Unless Otherwise Noted)

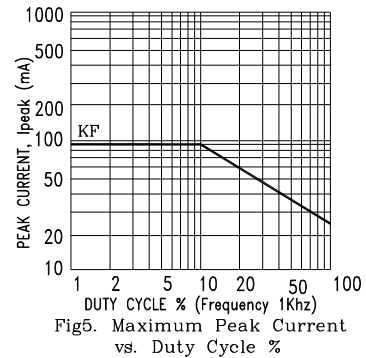
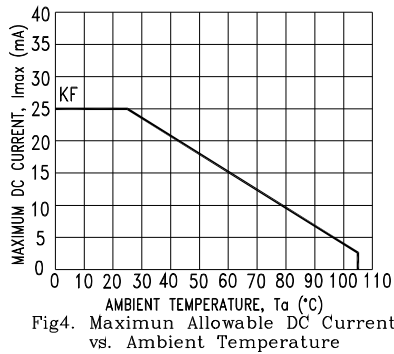
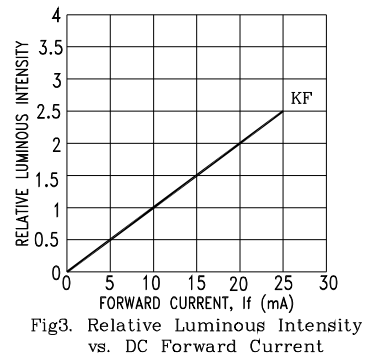
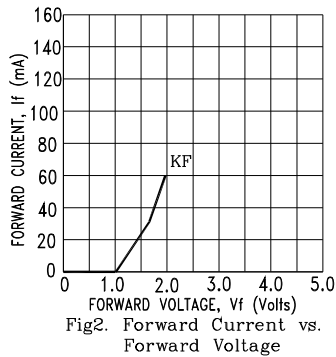
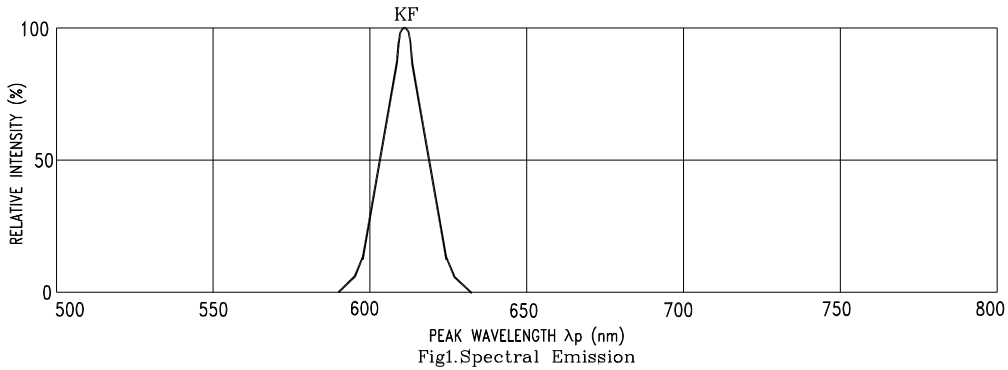

NOTE : JF=AlInGaP YELLOW ORANGE