



MKV AC capacitors

Damping, Commutating

Ordering code: B25834
Date: September 2005

© EPCOS AG 2005. Reproduction, publication and dissemination of this data sheet, enclosures hereto and the information contained therein without EPCOS' prior express consent is prohibited.

Features

- High dielectric strength
- High peak-current capability

Applications

- For damping and commutating in the medium frequency range
- For general AC applications

Construction

- Self-healing
- Plastic dielectric
- Oil-impregnated tubular windings (no PCB)
- Metal-sprayed end faces ensure reliable contacting
- Cylindrical aluminum case
- Plastic or ceramic lead-throughs
- Mounting bolts M8 or M12

Terminals

- Screw terminals M10
- Tab connectors 6.3 mm
- Dual tab connectors 6.3 mm and 9.5 mm

Mounting

- If the vibration stress is $\leq 5 g$ and the capacitors are ≤ 60 mm in diameter and ≤ 160 mm in height, the bolt is used for mounting.

Grounding

- Mounting bolts for grounding in accordance with VDE 0100
- Grounding identification in accordance with DIN 40 011

Overpressure disconnecter (mechanical)

When the overpressure disconnecter responds, the capacitor extends by up to 8 mm.

So leave sufficient space above the terminals when mounting the capacitor.

Individual data sheets

Individual data sheets contain detailed specification incl. thermal data. Upon request, these data sheets are available for each capacitor type.



Technical data

Standards		IEC 1071-1/2 EN 61071-1/2 VDE 0560 part 120 and 121			
Dielectric dissipation factor	$\tan \delta_0$	2×10^{-4}			
Capacitance tolerance		For $C_N < 1.0 \mu\text{F} \pm 20\%$, for $C_N \geq 1.0 \mu\text{F} \pm 10\%$			
Max. repetitive rate of voltage rise	$(du/dt)_{\max}$	$\frac{\hat{I}}{C}$			
Max. non-repetitive rate of voltage rise	$(du/dt)_s$	$\frac{I_s}{C}$			
Climatic data:					
Min. operating temperature	T_{\min}	- 25 °C			
Max. operating temperature	T_{\max}	+ 85 °C			
Average relative humidity		≤ 95 % (screw terminals/dual tab 9.5 mm) ≤ 75 % (dual tab 6.3 mm/tab 6.3 mm)			
Failure quota	$\alpha_{\text{FQ}(\text{co})}$	300 failures per 10^9 component hours			
Load duration	$t_{\text{LD}(\text{co})}$	100 000 h			
Storage temperature limit	T_{stg}	- 55/+ 85 °C			
IEC climatic category (IEC 68-1 and 2)		25/085/56			
Test A, cold		- 25 °C			
Test B, dry heat		+ 85 °C			
Test Ca, damp heat, steady state		56 days/40 °C/93 % rel. humidity			
Values after test Ca:					
Capacitance change	$\Delta C/C$	≤ 1 %			
		C_R	Screw terminals, dual tab 9.5 mm	Dual tab 6.3 mm	Tab 6.3 mm
Insulation resistance	R_{ins}	≤ 1 μF	≥ 10 000 MΩ	≥ 3000 MΩ	≥ 1000 MΩ
Self-discharge time constant	$\tau = R_{\text{ins}} \times C$	> 1 μF	≥ 10 000 s	≥ 3000 s	≥ 1000 s
Dissipation factor change	$\Delta \tan \delta$	≤ 1 x 10 ⁻⁴		≤ 3 x 10 ⁻⁴	≤ 3 x 10 ⁻⁴
Test data:					
AC test voltage					
between terminals	V_{TT}	1.25 x V_N , 50 Hz, 10 s (or DC 1.75 x V_N , 10 s)			
between terminals and case	V_{TC}	2 x V_i + 1000 V, 50 Hz, 10 s Insulating voltage V_i = max. recurrent peak voltage $\hat{v} / \sqrt{2}$			
		C_R	Screw terminals, dual tab 9.5 mm	Dual tab 6.3 mm, tab 6.3 mm	
Insulation resistance	R_{ins}	≤ 1 μF	≥ 10 000 MΩ	≥ 3000 MΩ	
Self-discharge time constant	$\tau = R_{\text{ins}} \times C$	> 1 μF	≥ 10 000 s	≥ 3000 s	
Dissipation factor (50 Hz)	$\tan \delta$	≤ 3 x 10 ⁻⁴			

Characteristics and ordering codes

$C_R^{1)}$	I_{max}	\hat{i}	I_s	R_S 20 °C	L_{self}	Dimensions d × l	Fig.	Appr. weight	Ordering code
μF	A	A	A	mΩ	nH	mm		g	
$V_R = AC 500 V$									
				$\hat{v} = 600 V$		$V_{TT} = AC 620 V, 10 s$			
				$v_s = 860 V$		$V_{TC} = AC 2000 V, 10 s$			
33	18	1300	3300	4.9	90	60 × 86	3	290	B25834-L3336-K009
47	80	1900	4700	1.9	110	79.2 × 104	2	610	B25834-D3476-K004
68	80	2700	6800	1.5	110	99.3 × 104	2	970	B25834-D3686-K004
100	80	4000	10000	1.4	180	79.2 × 248	2	1500	B25834-D3107-K004
220	80	8800	22000	1.2	180	99.3 × 248	2	2300	B25834-D3227-K004
$V_R = AC 600 V$									
				$\hat{v} = 750 V$		$V_{TT} = AC 750 V, 10 s$			
				$v_s = 1000 V$		$V_{TC} = AC 2100 V, 10 s$			
0.68	10	110	270	25.0	50	25 × 48	5	30	B25834-F4684-M001
1.0	10	160	400	18.0	50	25 × 48	5	30	B25834-F4105-K001
1.5	16	240	600	14.0	50	30 × 48	6	50	B25834-F4155-K001
2.2	16	350	880	10.0	50	30 × 48	6	50	B25834-F4225-K001
3.3	16	530	1300	8.7	50	35 × 48	7	60	B25834-F4335-K001
4.7	16	190	470	16.0	90	30 × 80	6	70	B25834-F4475-K001
6.8	16	270	680	13.0	90	35 × 80	7	100	B25834-F4685-K001
10	18	400	1000	8.0	90	40 × 86	3	130	B25834-L4106-K009
15	18	600	1500	6.5	90	50 × 86	3	200	B25834-L4156-K009
22	60	880	2200	3.1	110	64.2 × 104	2	400	B25834-D4226-K004
33	80	1300	3300	2.4	110	79.2 × 104	2	610	B25834-D4336-K004
33	64	1300	3300	2.4	110	79.2 × 104	4	610	B25834-D4336-K009
47	80	1900	4700	2.0	110	89.3 × 104	2	780	B25834-D4476-K004
47	64	1900	4700	2.0	110	89.3 × 104	4	780	B25834-D4476-K009
68	80	2700	6800	1.7	180	64.2 × 248	2	960	B25834-D4686-K004
100	80	4000	10000	1.5	180	79.2 × 248	2	1500	B25834-D4107-K004
150	80	6000	15000	1.3	180	89.3 × 248	2	1900	B25834-D4157-K004
$V_R = AC 750 V$									
				$\hat{v} = 940 V$		$V_{TT} = AC 930 V, 10 s$			
				$v_s = 1300 V$		$V_{TC} = AC 2400 V, 10 s$			
4.7	16	240	590	13.0	90	35.0 × 80	7	100	B25834-F5475-K001
6.8	18	340	850	8.4	90	40.0 × 86	3	130	B25834-L5685-K009
10	18	500	1250	7.0	90	50.0 × 86	3	200	B25834-L5106-K009
15	18	750	1900	5.9	90	60.0 × 86	3	290	B25834-L5156-K009
22	80	1100	2800	2.6	110	79.2 × 104	2	610	B25834-D5226-K004
22	64	1100	2800	2.5	110	79.2 × 104	4	610	B25834-D5226-K009
33	80	1700	4100	2.0	110	89.3 × 104	2	780	B25834-D5336-K004

1) Other capacitance values upon request

Characteristics and ordering codes

$C_R^{1)}$	I_{max}	\hat{i}	I_s	R_S 20 °C	L_{self}	Dimensions d × l	Fig.	Appr. weight	Ordering code
μF	A	A	A	mΩ	nH	mm		g	
33	64	1700	4100	1.9	110	89.3 × 104	4	780	B25834-D5336-K009
47	80	2400	5900	1.7	180	64.2 × 248	2	960	B25834-D5476-K004
68	80	3400	8500	1.6	180	79.2 × 248	2	1500	B25834-D5686-K004
100	80	5000	12500	1.4	180	89.3 × 248	2	1900	B25834-D5107-K004
$\hat{v} = 1100 \text{ V}$ $V_{TT} = \text{AC } 1150 \text{ V, } 10 \text{ s}$ $v_s = 1500 \text{ V}$ $V_{TC} = \text{AC } 2600 \text{ V, } 10 \text{ s}$									
0.10	10	50	120	33.0	50	25.0 × 48	5	30	B25834-F6104-M001
0.15	10	70	180	24.0	50	25.0 × 48	5	30	B25834-F6154-M001
0.22	10	100	260	17.0	50	25.0 × 48	5	30	B25834-F6224-M001
0.33	10	90	220	29.0	50	25.0 × 48	5	30	B25834-F6334-M001
0.47	10	130	320	21.0	50	25.0 × 48	5	30	B25834-F6474-M001
0.68	10	180	460	16.0	50	25.0 × 48	5	30	B25834-F6684-M001
1.0	16	300	750	12.0	50	30.0 × 48	6	50	B25834-F6105-K001
1.5	16	450	1100	9.8	50	35.0 × 48	7	60	B25834-F6155-K001
2.2	16	150	390	18.0	90	30.0 × 80	6	70	B25834-F6225-K001
3.3	16	230	580	14.0	90	35.0 × 80	7	100	B25834-F6335-K001
4.7	18	330	820	9.0	90	40.0 × 86	3	130	B25834-L6475-K009
6.8	18	480	1200	7.3	90	50.0 × 86	3	200	B25834-L6685-K009
10	18	700	1750	6.1	90	60.0 × 86	3	290	B25834-L6106-K009
15	60	1100	2600	2.8	100	79.2 × 104	2	610	B25834-D6156-K004
15	60	1100	2600	2.7	100	79.2 × 104	4	610	B25834-D6156-K009
22	80	1500	3900	2.2	110	89.3 × 104	2	780	B25834-D6226-K004
22	64	1500	3900	2.1	110	89.3 × 104	4	780	B25834-D6226-K009
33	80	2300	5800	1.8	180	64.2 × 248	2	960	B25834-D6336-K004
47	80	3300	8200	1.6	180	79.2 × 248	2	1500	B25834-D6476-K004
68	80	4800	12000	1.4	180	89.3 × 248	2	1900	B25834-D6686-K004
$\hat{v} = 1400 \text{ V}$ $V_{TT} = \text{AC } 1400 \text{ V, } 10 \text{ s}$ $v_s = 1900 \text{ V}$ $V_{TC} = \text{AC } 3000 \text{ V, } 10 \text{ s}$									
4.7	18	380	940	17.0	140	40.0 × 156	3	240	B25834-L7475-K009
6.8	18	540	1400	13.0	140	50.0 × 156	3	370	B25834-L7685-K009
10	60	800	2000	6.3	150	64.2 × 176	1	680	B25834-D7106-K004
15	80	1200	3000	4.9	150	79.2 × 176	1	1000	B25834-D7156-K004
22	80	1800	4400	3.7	150	89.3 × 176	1	1300	B25834-D7226-K004
33	80	2600	6600	2.8	150	99.3 × 176	1	1600	B25834-D7336-K004

1) Other capacitance values upon request

Characteristics and ordering codes

$C_R^{1)}$	I_{\max}	\hat{i}	I_s	R_S 20 °C	L_{self}	Dimensions $d \times l$	Fig.	Appr. weight	Ordering code
μF	A	A	A	$\text{m}\Omega$	nH	mm		g	
$V_R = \text{AC } 1400 \text{ V}$									
				$\hat{v} = 1800 \text{ V}$		$V_{\text{TT}} = \text{AC } 1800 \text{ V, } 10 \text{ s}$			
				$v_s = 2400 \text{ V}$		$V_{\text{TC}} = \text{AC } 3600 \text{ V, } 10 \text{ s}$			
4.7	60	470	1200	9.3	150	64.2×176	1	680	B25834-D0475-K004
6.8	60	680	1700	6.6	150	64.2×176	1	680	B25834-D0685-K004
10	80	1000	2500	5.2	150	79.2×176	1	1000	B25834-D0106-K004
15	80	1500	3800	3.8	150	89.3×176	1	1300	B25834-D0156-K004
22	80	2200	5500	2.9	150	99.3×176	1	1600	B25834-D0226-K004
$V_R = \text{AC } 1700 \text{ V}$									
				$\hat{v} = 2100 \text{ V}$		$V_{\text{TT}} = \text{AC } 2100 \text{ V, } 10 \text{ s}$			
				$v_s = 2900 \text{ V}$		$V_{\text{TC}} = \text{AC } 4000 \text{ V, } 10 \text{ s}$			
4.7	60	560	1400	13.0	220	64.2×248	1	960	B25834-D1475-K004
6.8	60	820	2000	9.0	220	64.2×248	1	960	B25834-D1685-K004
10	80	1200	3000	7.0	220	79.2×248	1	1500	B25834-D1106-K004
15	80	1800	4500	5.3	220	89.3×248	1	1900	B25834-D1156-K004
22	80	2600	6600	3.9	220	99.3×248	1	2300	B25834-D1226-K004
$V_R = \text{AC } 2100 \text{ V}$									
				$\hat{v} = 2600 \text{ V}$		$V_{\text{TT}} = \text{AC } 2600 \text{ V, } 10 \text{ s}$			
				$v_s = 3600 \text{ V}$		$V_{\text{TC}} = \text{AC } 4800 \text{ V, } 10 \text{ s}$			
3.3	60	530	1300	13.0	220	64.2×248	1	960	B25834-D2335-K004
4.7	60	750	1900	9.4	220	64.2×248	1	960	B25834-D2475-K004
6.8	80	1100	2700	7.4	220	79.2×248	1	1500	B25834-D2685-K004
10	80	1600	4000	5.4	220	89.3×248	1	1900	B25834-D2106-K004
15	80	2400	6000	4.1	220	99.3×248	1	2300	B25834-D2156-K004

1) Other capacitance values upon request

Dimensional drawing 1

Screw terminals M10 (Dimensions in mm)

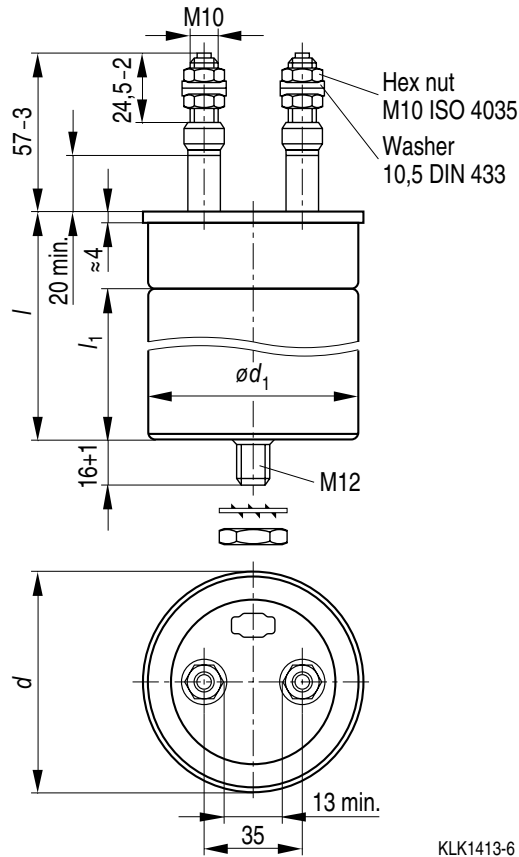
Dimensional drawing 2

Screw terminals M10 (Dimensions in mm)

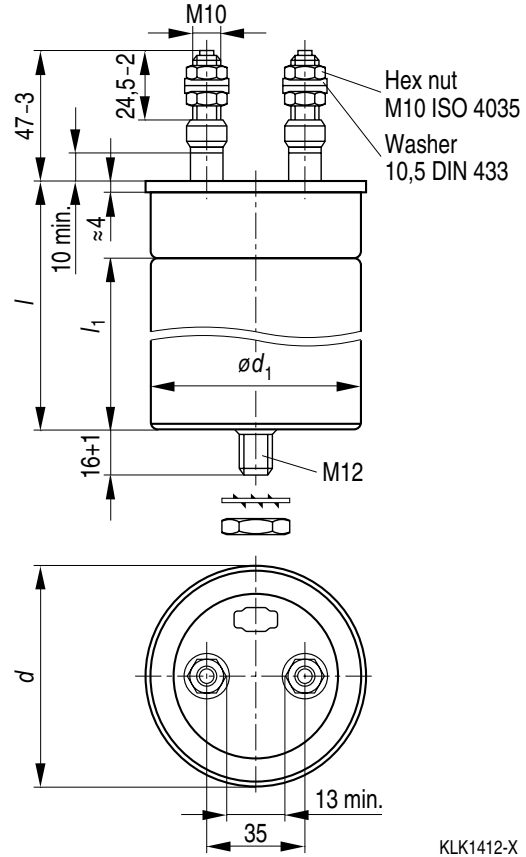

1) Dimensions for guidance only, subject for modification

d-1,2	l-4	∅ d ₁ -0,4	l ₁ min	Creepage distance	Clearance
64.2	176	60.2	135	20	13
64.2	248	60.2	204		
79.2	176	75.2	135		
79.2	248	75.2	204		
89.3	176	85.2	135		
89.3	248	85.2	204		
99.3	176	95.2	135		
99.3	248	95.2	204		
Max. torque terminals*)				7 Nm	

d-1,2	l-4	∅ d ₁ -0,4	l ₁ min	Creepage distance	Clearance
64.2	104	60.2	135	10	10
64.2	248	60.2	204		
79.2	104	75.2	75		
79.2	248	75.2	204		
89.3	104	85.2	75		
89.3	248	85.2	204		
99.3	104	95.2	75		
99.3	248	95.2	204		
Max. torque terminals*)				7 Nm	

*) The terminal torque must not act upon the ceramic. So the lead should be locked between two nuts..

Mounting parts (included in delivery)

Threaded bolt	Max. torque	Toothed washer	Hex nut
M12	10 Nm	J 12,5 DIN 6797	M12 DIN 439

Dimensional drawing 3

Dual tab connectors 6.3 mm

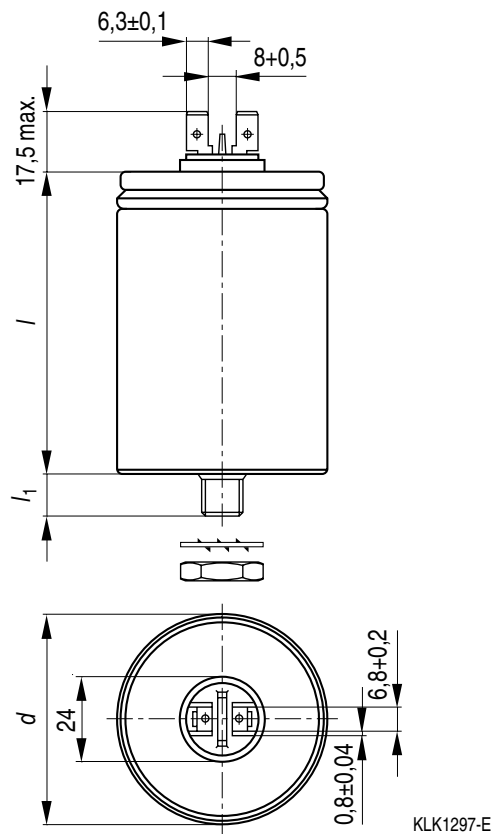

Dimensions in mm

$d \pm 0,5$ _{-0,2}	$l \pm 1$ ₋₂	$l_1 + 1^*)$	Creepage distance	Clearance
40	86	8	10	6
40	156	8		
50	86	12	10	6
50	156	12		
60	86	12		

*) 8 mm = threaded bolt M8
12 mm = threaded bolt M12

Dimensional drawing 4

Dual tab connectors 9.5 mm

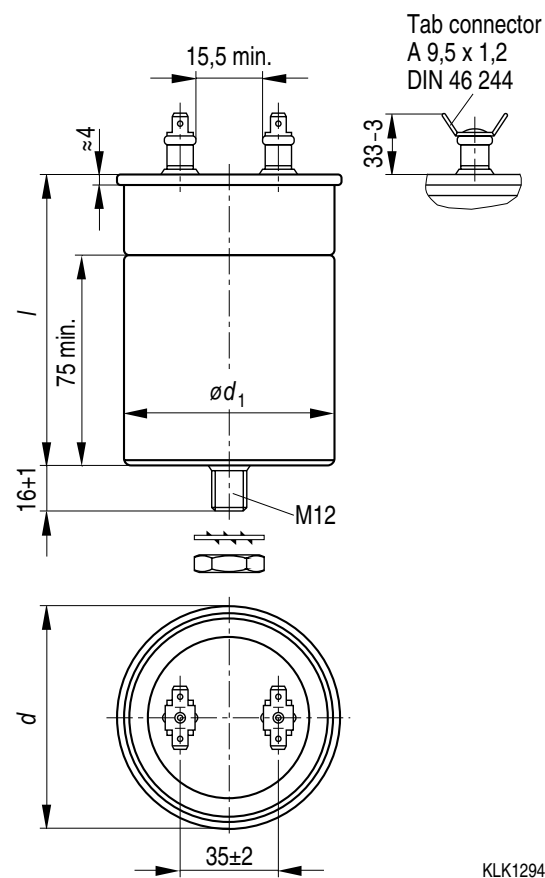

Dimensions in mm

$d - 1,2$	$l - 4$	$\varnothing d_1 - 0,4$	Creepage distance	Clearance
79.2	104	75.2	10	10
89.3	104	85.2		

Mounting parts (included in delivery)

Toothed washer	Hex nut
J 8.2 DIN 6797	M 8 ISO 4035
J 12.5 DIN 6797	M12 ISO 4035

Dimensional drawing 5

Tab connectors 6.3 mm

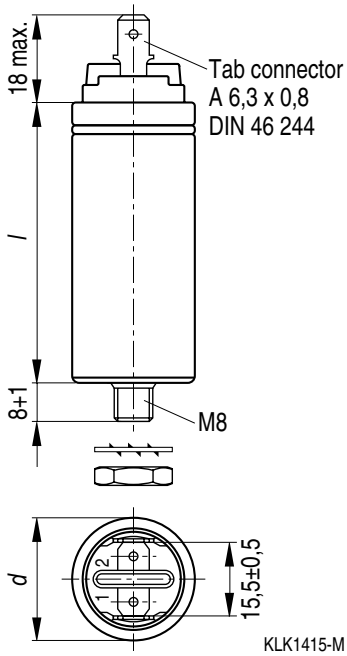
Dimensional drawing 6

Tab connectors 6.3 mm

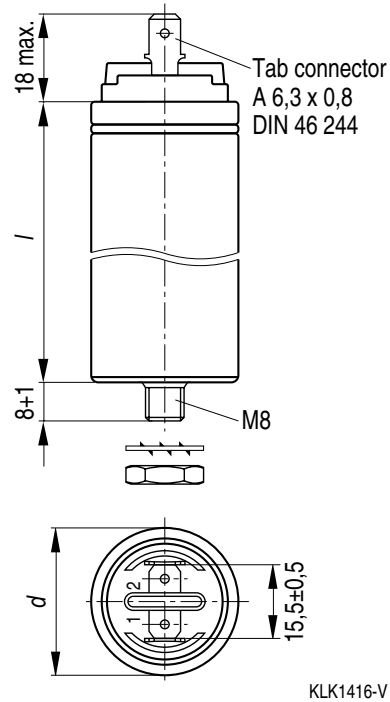

Dimensions in mm

$d \pm 0,5$	$l \pm 2$	Creepage distance	Clearance
25	48	9	7

Dimensions in mm

$d \pm 0,5$	$l \pm 2$	Creepage distance	Clearance
30	48	9	7
30	80		

Mounting parts (included in delivery)

Threaded bolt	Max. torque	Toothed washer	Hex nut
M8	4 Nm	J 8.2 DIN 6797	M 8 DIN 439

Dimensional drawing 7

Tab connectors 6,3 mm

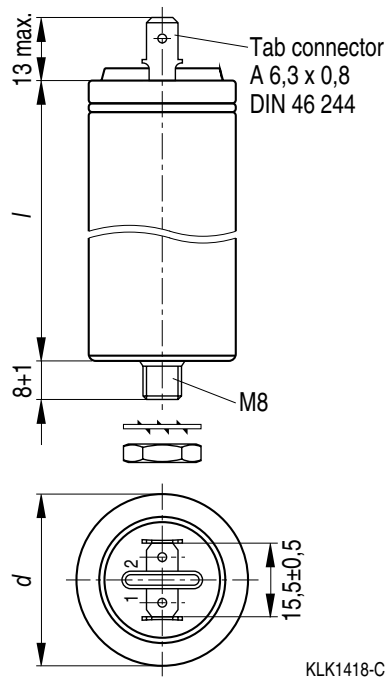
Dimensions in mm

$d \pm \begin{smallmatrix} 0,5 \\ -0,2 \end{smallmatrix}$	$l \pm 2$	Creepage distance	Clearance
35	48	6	6
35	80		

Mounting parts (included in delivery)

Threaded bolt	Max. torque	Toothed washer	Hex nut
M8	4 Nm	J 8,2 DIN 6797	M 8 DIN 439

Cautions and warnings

Safety

- In case of dents of more than 1 mm depth or any other mechanical damage, capacitors must not be used at all. This applies also in cases of oil leakage.
- Electrical or mechanical misapplication of capacitors may be hazardous. Personal injury or property damage may result from bursting of the capacitor or from expulsion of oil or melted material due to mechanical disruption of the capacitor.
- Ensure good, effective grounding for capacitor enclosures.
- Observe appropriate safety precautions during operation (self-recharging phenomena and the high energy contained in capacitors).
- Handle capacitors carefully, because they may still be charged even after disconnection.
- The terminals of capacitors, connected bus bars and cables as well as other devices may also be energized.
- Follow good engineering practice.
- Failure to follow cautions may result, worst case, in premature failures, bursting and fire.

Thermal load

After installation of the capacitor it is necessary to verify that maximum hot-spot temperature is not exceeded at extreme service conditions (see www.epcos.com/thermal_design).

Mechanical protection

The capacitor has to be installed in a way that mechanical damages and dents in the aluminum can be avoided.

Storage and Operating Conditions

Do not use or store capacitors in corrosive atmosphere especially where chloride gas, sulfide gas, acid, alkali, salt or the like are present. In dusty environments, regular maintenance and cleaning especially of the terminals is required to avoid conductive path between phases and/or phases and ground.

Overpressure disconnecter

To ensure full functionality of an overpressure disconnecter, the following must be observed:

- The elastic elements must not be hindered, i.e.
 - connecting lines must be flexible leads (cables),
 - there must be sufficient space (minimum 12 mm) above the connections for expansion of the overpressure disconnecter,
 - folding crimps must not be retained by clamps.
- Stress parameters of the capacitor must be within the IEC61071 specification.

Service life expectancy

Electrical components do not have an unlimited service life expectancy; this applies to self-healing capacitors too. The maximum service life expectancy may vary depending on the application the capacitor is used in.

Important notes

The following applies to all products named in this publication:

1. Some parts of this publication contain **statements about the suitability of our products for certain areas of application**. These statements are based on our knowledge of typical requirements that are often placed on our products in the areas of application concerned. We nevertheless expressly point out **that such statements cannot be regarded as binding statements about the suitability of our products for a particular customer application**.
As a rule, EPCOS is either unfamiliar with individual customer applications or less familiar with them than the customers themselves. For these reasons, it is always ultimately incumbent on the customer to check and decide whether an EPCOS product with the properties described in the product specification is suitable for use in a particular customer application.
2. We also point out that **in individual cases, a malfunction of passive electronic components or failure before the end of their usual service life cannot be completely ruled out in the current state of the art, even if they are operated as specified**. In customer applications requiring a very high level of operational safety and especially in customer applications in which the malfunction or failure of a passive electronic component could endanger human life or health (e.g. in accident prevention or life-saving systems), it must therefore be ensured by means of suitable design of the customer application or other action taken by the customer (e.g. installation of protective circuitry or redundancy) that no injury or damage is sustained by third parties in the event of malfunction or failure of a passive electronic component.
3. **The warnings, cautions and product-specific notes must be observed.**
4. In order to satisfy certain technical requirements, **some of the products described in this publication may contain substances subject to restrictions in certain jurisdictions (e.g. because they are classed as “hazardous”)**. Useful information on this will be found in our Material Data Sheets on the Internet (www.epcos.com/material). Should you have any more detailed questions, please contact our sales offices.
5. We constantly strive to improve our products. Consequently, **the products described in this publication may change from time to time**. The same is true of the corresponding product specifications. Please check therefore to what extent product descriptions and specifications contained in this publication are still applicable before or when you place an order.
We also **reserve the right to discontinue production and delivery of products**. Consequently, we cannot guarantee that all products named in this publication will always be available.
6. Unless otherwise agreed in individual contracts, **all orders are subject to the current version of the “General Terms of Delivery for Products and Services in the Electrical Industry” published by the German Electrical and Electronics Industry Association (ZVEI)**.
7. The trade names EPCOS, CeraDiode, CSSP, PhaseCap, PhaseMod, SilverCap, SIFI, SIMID, SIKOREL, SIOV, SIP5D, SIP5K, TOPcap, UltraCap, WindCap are **trademarks registered or pending** in Europe and in other countries. Further information will be found on the Internet at www.epcos.com/trademarks.