

## ADJUSTABLE HIGH PRECISION SHUNT REGULATOR

### ■ GENERAL DESCRIPTION

The **NJM2380/A, NJM2390/A** is an adjustable high precision shunt regulator.

It is adapted for downsizing power supply module, battery charger and others, because an ultra mini package SOT23(MTP5) is included in the package line-up.

### ■ PACKAGE OUTLINE

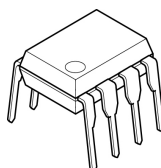

**NJM2380D/AD**



**NJM2380M/AM**



**NJM2380E/AE**

### ■ FEATURES

- Operating Voltage  $V_{REF}$  to 18V
- High Precision Voltage Reference 2.465V±2%  
2.465V±1% : A Version
- Mounted in Ultra Mini Package SOT23 (MTP5)
- Minimum External Parts
- Bipolar Technology
- Package Outline DIP8, DMP8, EMP8,  
SOT89 (3pin), SOT23 (MTP5)



**NJM2380U/AU**  
**NJM2390U/AU**



**NJM2380F/AF**

### ■ PIN CONFIGURATION

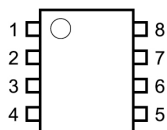

**NJM2380D/AD**  
**NJM2380M/AM**  
**NJM2380E/AE**

#### PIN FUNCTION

1. CATHODE
2. NC
3. NC
4. NC
5. NC
6. ANODE
7. NC
8. REFERENCE

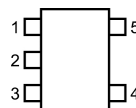

**NJM2380F/AF**

#### PIN FUNCTION

1. NC
2. ANODE
3. NC
4. CATHODE
5. REFERENCE

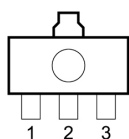

**NJM2380U/AU**

#### PIN FUNCTION

1. REFERENCE
2. ANODE
3. CATHODE

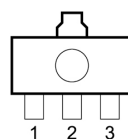

**NJM2390U/AU**

#### PIN FUNCTION

1. CATHODE
2. ANODE
3. REFERENCE

### ■ BLOCK DIAGRAM

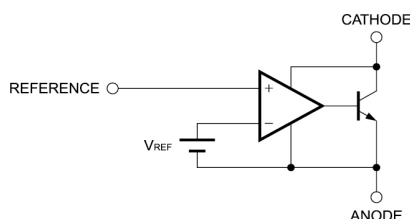

# NJM2380/A, NJM2390/A

## ■ ABSOLUTE MAXIMUM RATINGS

( $T_a=25^\circ\text{C}$ )

PARAMETER	SYMBOL	RATINGS	UNIT
Cathode Voltage	$V_{KA}$	+20	V
Continuous Cathode Current	$I_{KA}$	-100 to 150	mA
Reference Input Current	$I_{REF}$	-0.05 to 10	mA
Power Dissipation	$P_D$	(DIP8) 700 (DMP8) 300 (EMP8) 300 (SOT89) 350 (SOT23[MTP5]) 200	mW
Operating Temperature Range	$T_{OPR}$	-40 to +85	$^\circ\text{C}$
Storage Temperature Range	$T_{STG}$	-50 to +150	$^\circ\text{C}$

## ■ RECOMMENDED OPERATING CONDITIONS

PARAMETER	SYMBOL	MIN.	TYP.	MAX.	UNIT
Cathode Voltage	$V_{KA}$	$V_{REF}$	-	18	V
Cathode Current	$I_K$	1		100	mA

## ■ ELECTRICAL CHARACTERISTICS

( $I_K=10\text{mA}$ ,  $T_a=25^\circ\text{C}$ )

PARAMETER	SYMBOL	CONDITIONS	MIN.	TYP.	MAX.	UNIT
Reference Voltage	$V_{REF}$	$V_{KA}=V_{REF}(*1)$	2415	2465	2515	mV
		$V_{KA}=V_{REF}(*1)$ , A Version	2440	2465	2490	
Reference Voltage Change vs. Cathode Voltage Change	$V_{REF}/V_{KA}$	$ V_{REF}  \leq V_{KA} \leq 10V(*2)$	-	$\pm 1.4$	$\pm 2.7$	mV/V
		$10 \leq V_{KA} \leq 18V(*2)$	-	$\pm 1$	$\pm 2$	mV/V
Reference Input Current	$I_{REF}$	$R=10\text{k}\Omega$ , $R2=\infty(*2)$	-	2	4	$\mu\text{A}$
Minimum Input Current	$I_{MIN}$	$V_{KA}=V_{REF}(*1)$	-	0.4	1.0	mA
Cathode Current (Off Cond.)	$I_{OFF}$	$V_{KA}=18\text{V}$ , $V_{REF}=0V(*3)$	-	0.1	1.0	$\mu\text{A}$
Dynamic Impedance	$ Z_{KA} $	$V_{KA}=V_{REF}$ , $f \leq 1\text{kHz}$ $1\text{mA} \leq I_K \leq 100\text{mA}(*1)$	-	0.2	-	$\Omega$

## ■ TEMPERATURE CHARACTERISTICS

( $I_K=10\text{mA}$ ,  $T_a=-20$  to  $+85^\circ\text{C}$ )

PARAMETER	SYMBOL	CONDITIONS	MIN.	TYP.	MAX.	UNIT
Reference Voltage Change	$\Delta V_{REF}$	$V_{KA}=V_{REF}(*1)$	-	8	17	mV
Reference Input Current Change	$\Delta I_{REF}$	$R1=10\text{k}\Omega$ , $R2=\infty(*2)$	-	0.4	1.2	$\mu\text{A}$

The "Reference Voltage Change" and "Reference Input Current Change" is tested to using some samples of the first five lots. These "TEMPERATURE CHARACTERISTICS" are not guaranteed.

$|V_{REF}|$  ... Reference voltage includes error.

(\*1) : TEST CIRCUIT 1 (Fig.1)

(\*2) : TEST CIRCUIT 2 (Fig.2)

(\*3) : TEST CIRCUIT 3 (Fig.3)

## ■ TEST CIRCUIT

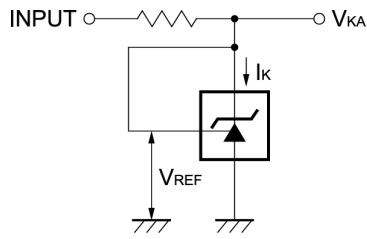

1,  $V_{KA} = V_{REF}$

$$V_O = V_{KA} = V_{REF}$$

(Fig.1)

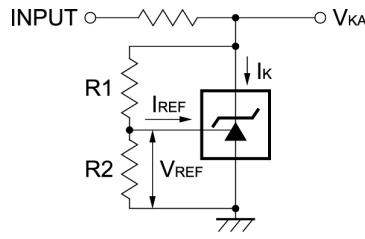

2,  $V_{KA} > V_{REF}$

$$V_O = V_{KA} = V_{REF} \cdot \left(1 + \frac{R1}{R2}\right) + I_{REF} \cdot R1$$

(Fig.2)

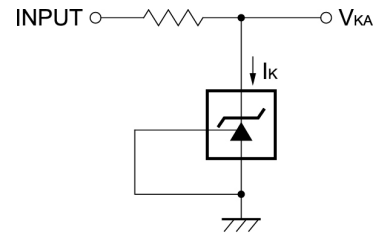

3,  $I_{OFF}$

(Fig.3)

## ■ POWER DISSIPATION VS. AMBIENT TEMPERATURE

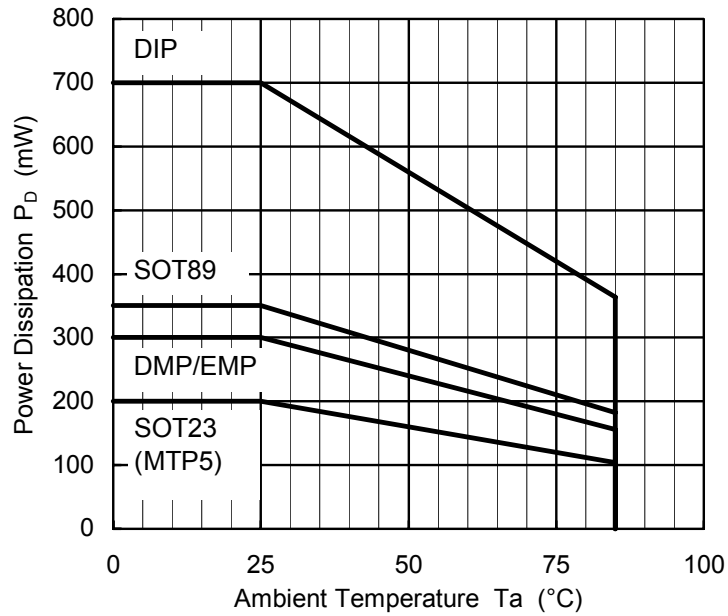

# NJM2380/A, NJM2390/A

## TYPICAL CHARACTERISTICS

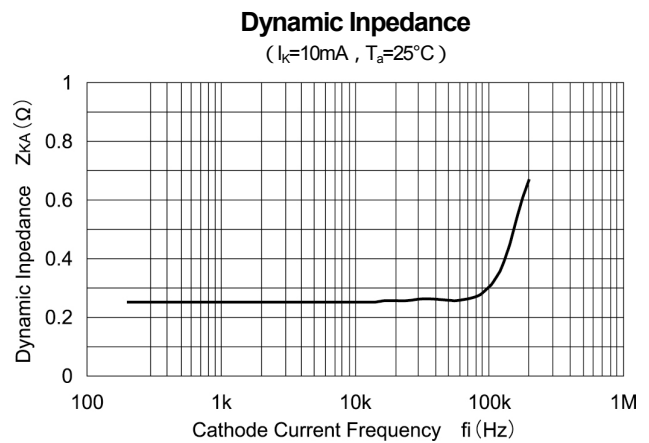
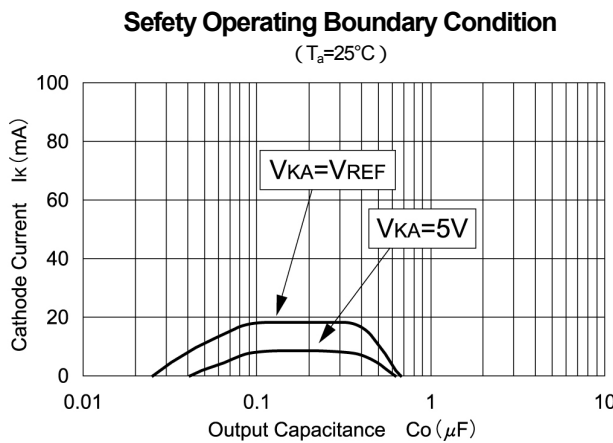
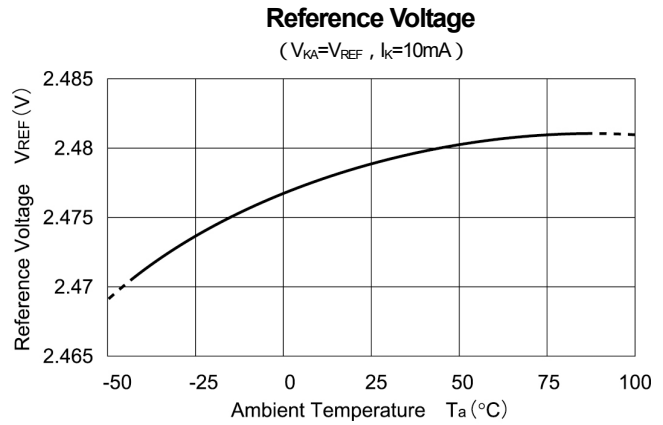
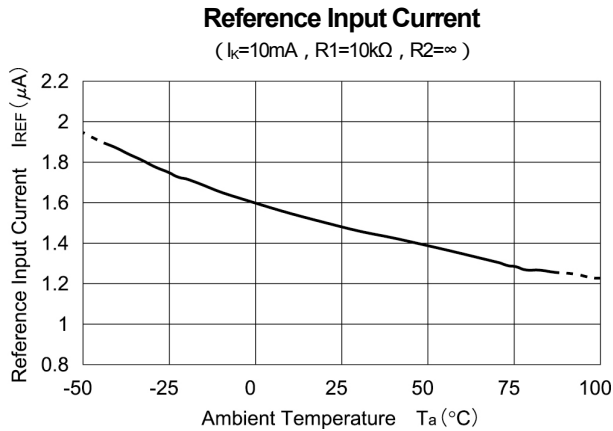
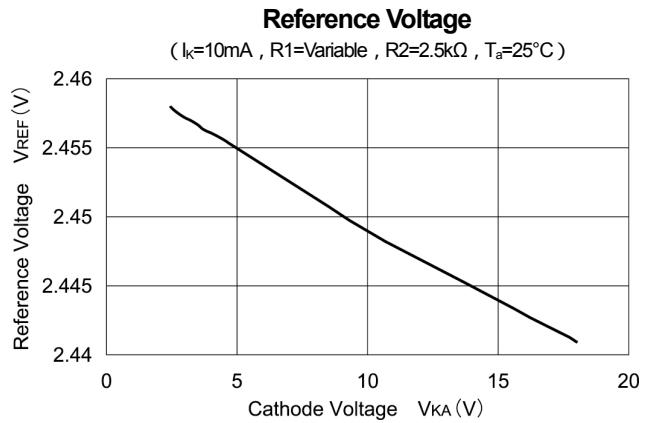
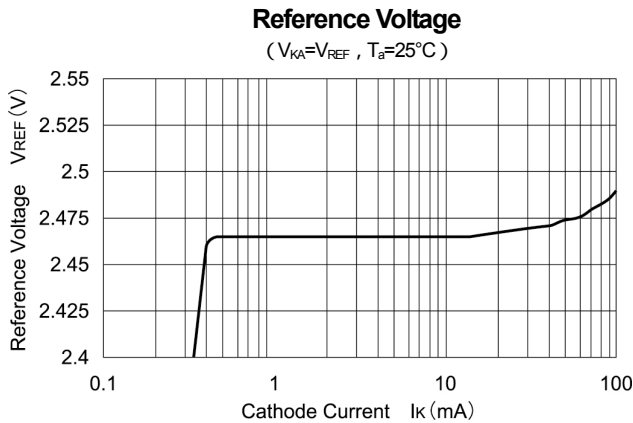

Note) Oscillation might occur while operating within the range of safety curve.  
So that, it is necessary to make ample margins by taking considerations of fluctuation of the device.

[CAUTION]  
The specifications on this databook are only given for information, without any guarantee as regards either mistakes or omissions. The application circuits in this databook are described only to show representative usages of the product and not intended for the guarantee or permission of any right including the industrial rights.