



P1696

LINEAR INTEGRATED CIRCUIT

150KHZ, 2A PWM STEP-DOWN DC/DC CONVERTER

DESCRIPTION

The UTC **P1696** series is a step-down switching regulator able to provide 2A output current. The available output voltages are 2.5V 3.3V, 5V, 12V, and an adjustable output version.

FEATURES

- *Output load current: 2A
- *Adjustable version output voltage range, 1.23V ~ 17.5V±4%
- *Operating voltage can be up to 24V
- *Low power standby mode
- *High efficiency
- *Internal current and thermal limit

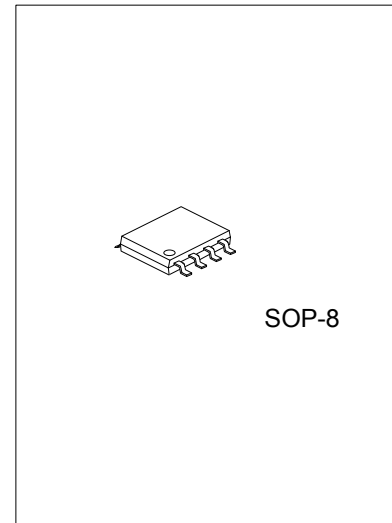

SOP-8

*Pb-free plating product number:P1696L

ORDERING INFORMATION

Ordering Number		Package	Packing
Normal	Lead Free Plating		
P1696-xx-S08-R	P1696L-xx-S08-R	SOP-8	Tape Reel
P1696-xx-S08-T	P1696L-xx-S08-T	SOP-8	Tube

<p>P1696L-xx-S08-R</p> <p>(1)Packing Type (2)Package Type (3)Output Voltage Code (4)Lead Plating</p>	<p>(1) R: Tape Reel, T: Tube (2) S08: SOP-8 (3) xx: 25:2.5V, 33:3.3V, 50:5.0V, 12:12V, AD:ADJ (4) L: Lead Free Plating, Blank: Pb/Sn</p>
--	--

PIN DESCRIPTION

PIN NO.	PIN NAME	DESCRIPTION
1	V _{IN}	Operating voltage input
2	Output	Switching output
3	FB (Feedback)	Output voltage feedback control
4	SD (Shutdown)	ON/OFF shutdown
5,6,7,8	GND	Circuit ground

■ BLOCK DIAGRAM

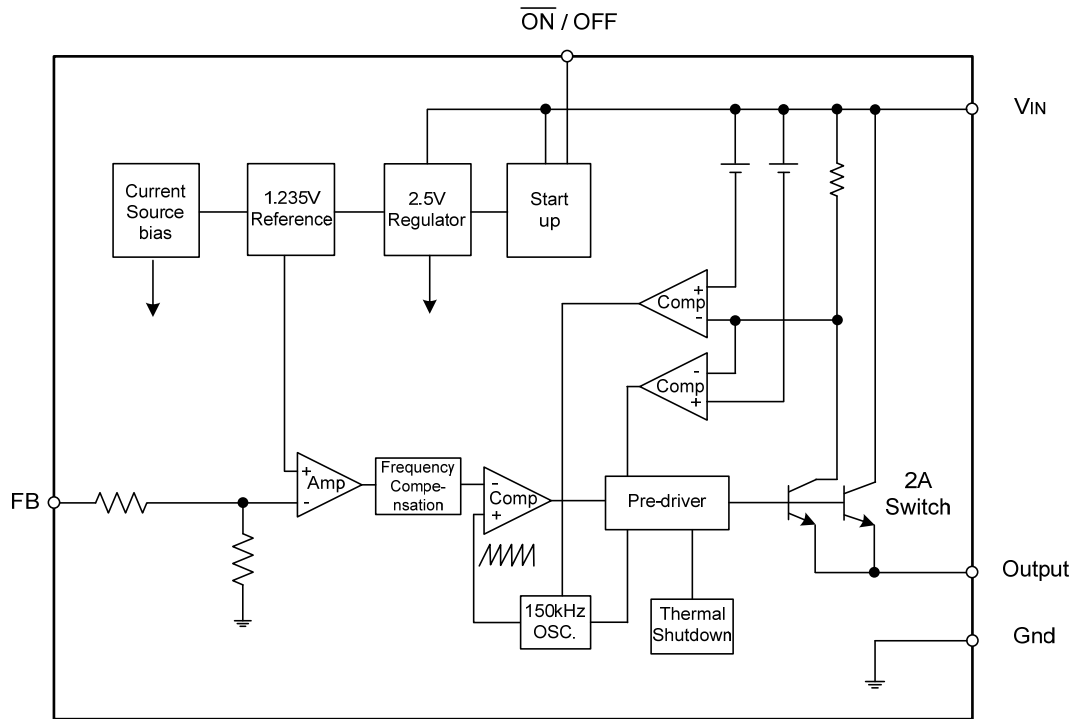

■ ABSOLUTE MAXIMUM RATINGS

PARAMETER	SYMBOL	RATINGS	UNIT
Maximum Supply Voltage	V_{CC}	28	V
Operating Voltage	V_{OPR}	4.5 ~ 20	V
ON/OFF Pin Input Voltage	$V_{ON/OFF}$	-0.3 ~ +12	V
Feedback Pin Voltage	V_{FB}	-0.3 ~ +12	V
Output Voltage to Ground (Steady State)	V_{OUT}	-1	V
Power Dissipation	P_D	Internally limited	mW
Junction Temperature	T_J	+150	°C
Operating Temperature	T_{OPR}	-40 ~ +125	°C
Storage Temperature	T_{STG}	-40 ~ +150	°C

Note: Absolute maximum ratings are those values beyond which the device could be permanently damaged.

Absolute maximum ratings are stress ratings only and functional device operation is not implied.

■ ELECTRICAL CHARACTERISTICS

($T_J=25^\circ\text{C}$, $V_{IN}=12\text{V}$ for the 2.5V 3.3V, 5V, and Adjustable version and $V_{IN}=24\text{V}$ for the 12V version, $I_{LOAD}=500\text{mA}$.)

PARAMETER	SYMBOL	TEST CONDITIONS	MIN	TYP	MAX	UNIT	
Output Voltage	2.5V	V_{OUT}	$5.0\text{V} \leq V_{IN} \leq 24\text{V}$, $0.2\text{A} \leq I_{LOAD} \leq 2\text{A}$	2.4	2.5	2.6	V
	3.3V		$6.0\text{V} \leq V_{IN} \leq 24\text{V}$, $0.2\text{A} \leq I_{LOAD} \leq 2\text{A}$	3.168	3.3	3.432	V
	5.0V		$7.5\text{V} \leq V_{IN} \leq 24\text{V}$, $0.2\text{A} \leq I_{LOAD} \leq 2\text{A}$	4.8	5.0	5.2	V
	12V		$15\text{V} \leq V_{IN} \leq 24\text{V}$, $0.2\text{A} \leq I_{LOAD} \leq 2\text{A}$	11.52	12.0	12.48	V
Efficiency	2.5V	η	$V_{IN}=12\text{V}$, $I_{LOAD}=2\text{A}$		73		%
	3.3V		$V_{IN}=12\text{V}$, $I_{LOAD}=2\text{A}$		75		%
	5.0V		$V_{IN}=12\text{V}$, $I_{LOAD}=2\text{A}$		80		%
	12V		$V_{IN}=24\text{V}$, $I_{LOAD}=2\text{A}$		80		%
UTC P1696-ADJ							
Feedback Voltage	VFB	$4.5\text{V} \leq V_{IN} \leq 24\text{V}$, $0.2\text{A} \leq I_{LOAD} \leq 2\text{A}$ V_{OUT} programmed for 3V	1.19	1.230	1.267	V	
Efficiency	η	$V_{IN}=12\text{V}$, $V_{OUT}=3\text{V}$, $I_{LOAD}=2\text{A}$		75		%	
ALL OUTPUT VOLTAGE							
Feedback Bias Current	I_{BIAS}	Adjustable Version Only, $V_{FB}=1.3\text{V}$		10	50	nA	
Oscillator Frequency	f_{OSC}	(Note 1)	127	150	173	kHz	
Saturation Voltage	V_{SAT}	$I_{OUT}=2\text{A}$ (Note 2, 3)		1.16	1.4	V	
Max Duty Cycle (ON)	DC	(Note 3)		100		%	
Min Duty Cycle (OFF)		(Note 4)		0			
Current Limit	I_{CL}	Peak Current (Notes 2, 3)		2		A	
Output Leakage Current	I_L	Output=0V (Notes 2, 4)			50	μA	
		Output=-1V (Note 5)		2	30	mA	
Quiescent Current	I_Q	(Note 4)		5	10	mA	
Standby Quiescent Current	I_{STBY}	ON/OFF Pin=5V (OFF) (Note 5)		80	200	μA	
ON/OFF CONTROL							
ON/OFF Pin Logic Input Threshold Volog	V_{IH}	Low (Regulator ON)		1.3	0.6	V	
	V_{IL}	High (Regulator OFF)	2.0	1.3		V	
ON/OFF Pin Input Current	I_H	VLOGIC=2.5V (Regulator OFF)		5	15	μA	
	I_L	VLOGIC=0.5V (Regulator ON)		0.02	5	μA	

Note 1: The switching frequency is reduced when the second stage current limit is activated.

2: No diode, inductor or capacitor connected to output pin.

3: Feedback pin removed from output and connected to 0V to force the output transistor switch ON.

4: Feedback pin removed from output and connected to 12V for the 2.5V 3.3V, 5V, and the ADJ. version, and 15V for the 12V version, to force the output transistor switch OFF.

5: $V_{IN} = 24\text{V}$

TYPICAL APPLICATION

(Fixed Output Voltage Version)

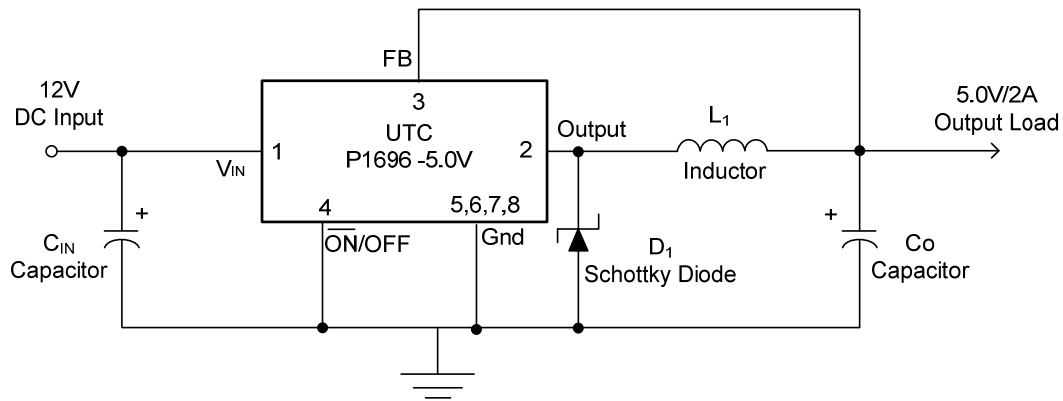

ADJUSTABLE OUTPUT VOLTAGE VERSIONS

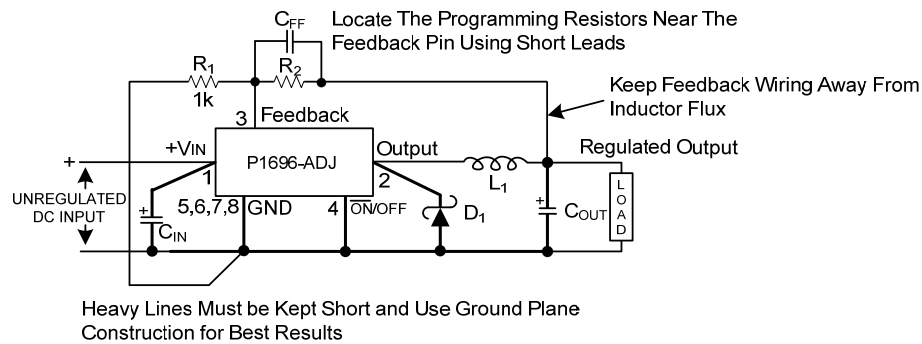

$$V_{OUT} \times \left(\frac{R_1}{R_1 + R_2} \right) = V_{REF}$$

$$V_{OUT} = V_{REF} \left(1 + \frac{R_2}{R_1} \right)$$

Where $V_{REF} = 1.23V$

$$R_2 = R_1 \left(\frac{V_{OUT}}{V_{REF}} - 1 \right)$$

TYPICAL CHARACTERISTICS

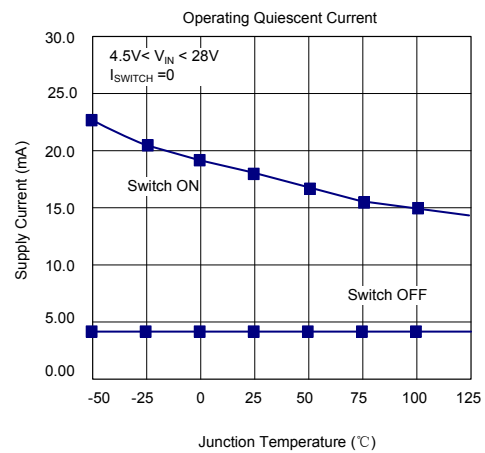
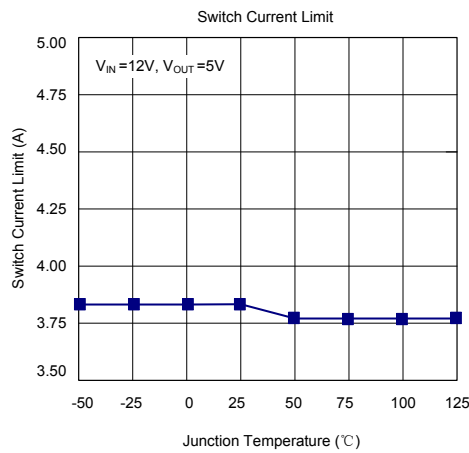
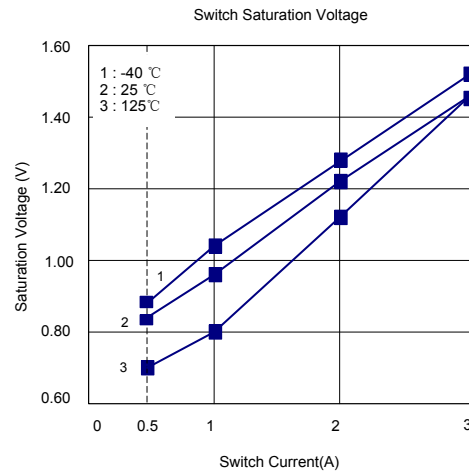
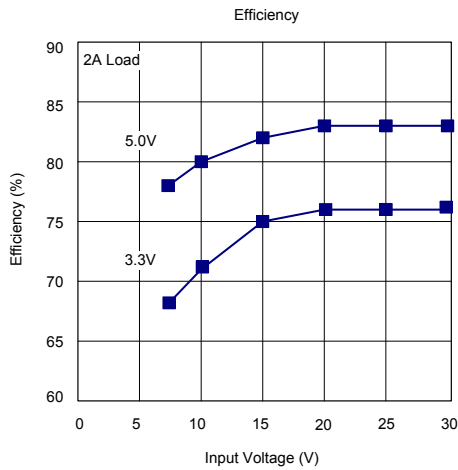
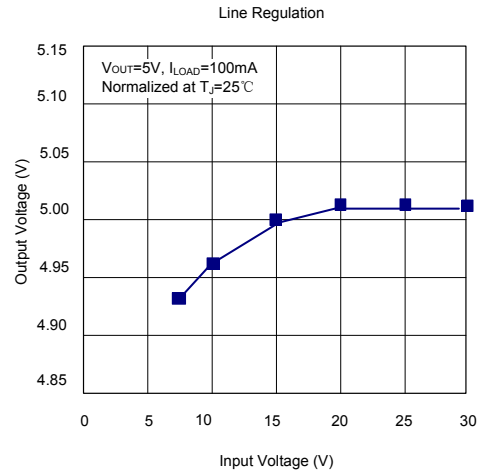
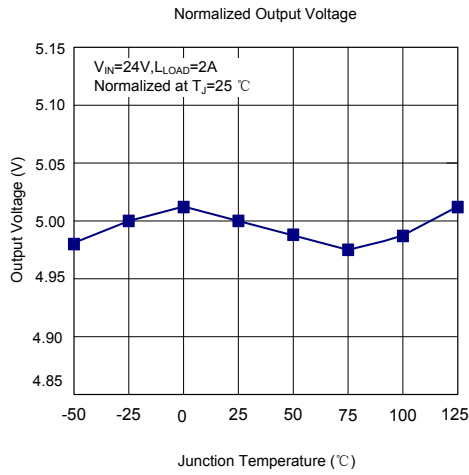

TYPICAL CHARACTERISTICS(Cont.)

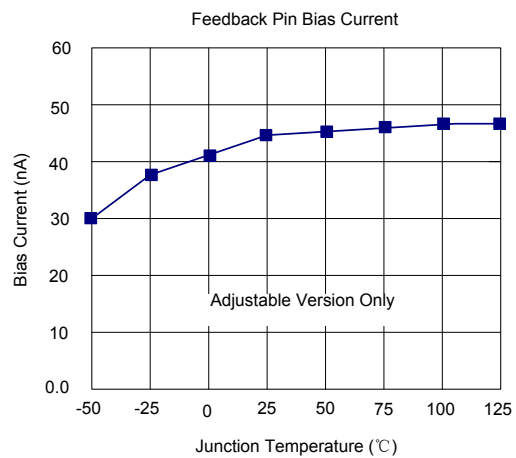
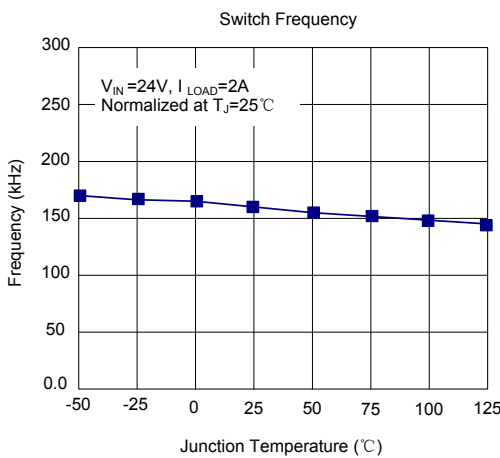
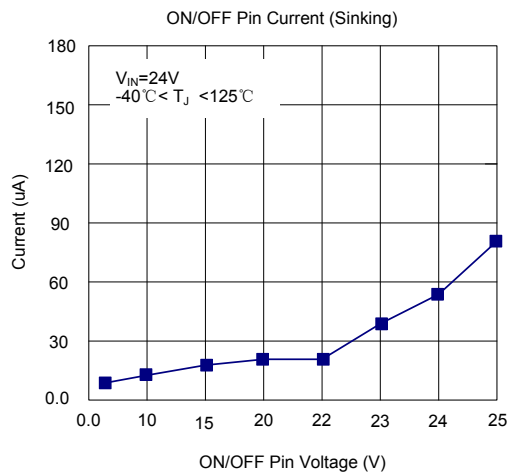
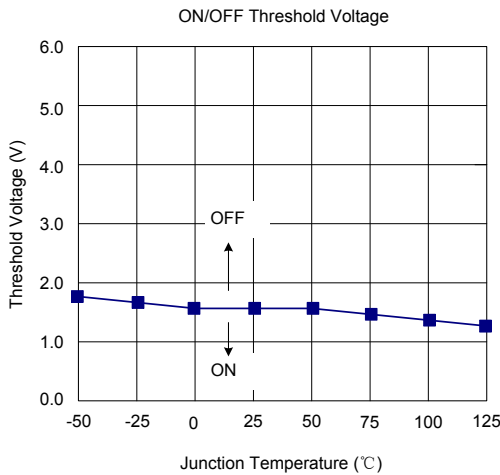
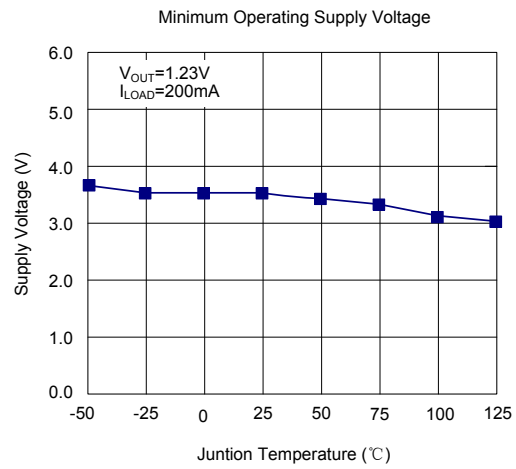
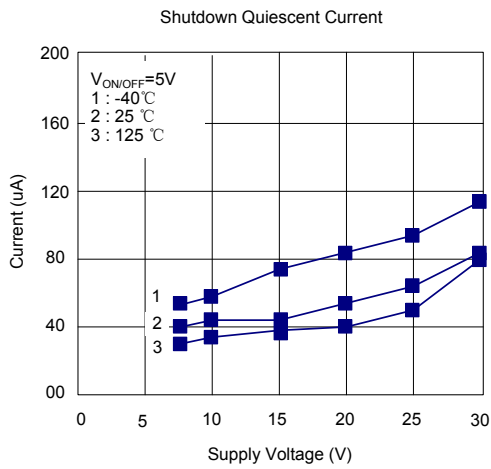

UTC assumes no responsibility for equipment failures that result from using products at values that exceed, even momentarily, rated values (such as maximum ratings, operating condition ranges, or other parameters) listed in products specifications of any and all UTC products described or contained herein. UTC products are not designed for use in life support appliances, devices or systems where malfunction of these products can be reasonably expected to result in personal injury. Reproduction in whole or in part is prohibited without the prior written consent of the copyright owner. The information presented in this document does not form part of any quotation or contract, is believed to be accurate and reliable and may be changed without notice.