

Product Brief

MCF5249PB/D
Rev. 0, 3/2002

MCF5249 Integrated
ColdFire® Microprocessor
Product Brief

Freescale Semiconductor, Inc.

This document provides an overview of the MCF5249 ColdFire® processor and general descriptions of MCF5249 features and modules.

The MCF5249 was designed as a system controller/decoder for MP3 music players, especially portable MP3 CD players. The 32-bit ColdFire core with Enhanced Multiply Accumulate (EMAC) unit provides optimum performance and code density for the combination of control code and signal processing required for MP3 decode, file management, and system control.

Low power features include a hardwired CD ROM decoder, advanced 0.18µm CMOS process technology, 1.8V core power supply, and on-chip 96 Kbyte SRAM. MP3 decode requires less than 20 MHz CPU bandwidth and runs in on-chip SRAM with external access only for data input and output.

The MCF5249 is also an excellent general purpose system controller with over 125 Dhrystone 2.1 MIPS @ 140 MHz performance at a very competitive price. The integrated peripherals and EMAC allow the MCF5249 to replace both the microcontroller and the DSP in certain applications. Most peripheral pins can also be remapped as general-purpose I/O pins.

1.1 MCF5249 Features: Introduction

The MCF5249 integrated microprocessor combines a Version 2 ColdFire® processor core operating at 140 MHz with the following modules:

- DMA controller with 4 DMA channels
- Integrated Enhanced Multiply-accumulate Unit (EMAC)
- 8-Kbyte Direct Mapped Instruction Cache
- 96-Kbyte SRAM (a 64K and 32K bank)
- Operates from external crystal oscillator
- Supports 16-bit wide SDRAM memories
- Serial Audio Interface which supports IIS and EIAJ audio protocols
- Digital audio transmitter and two receivers compliant with IEC958 audio protocol
- CD-ROM and CD-ROM XA block decoding and encoding function
- Two UARTs
- Queued Serial Peripheral Interface (QSPI) (Master Only)
- Two timers

**For More Information On This Product,
Go to: www.freescale.com**

Freescale Semiconductor, Inc.**MCF5249 Block Diagram**

- IDE and SmartMedia interfaces
- Analog/Digital Converter
- Flash Memory Card Interface
- Two I²C modules
- System debug support
- General Purpose I/O pins shared with other functions
- 1.8V core, 3.3V I/O
- 160 pin MAPBGA package (qualified at 140 MHz) and 144 pin QFP package (qualified at 120 MHz)

1.2 MCF5249 Block Diagram

Figure 1 shows the block diagram of the MCF5249.

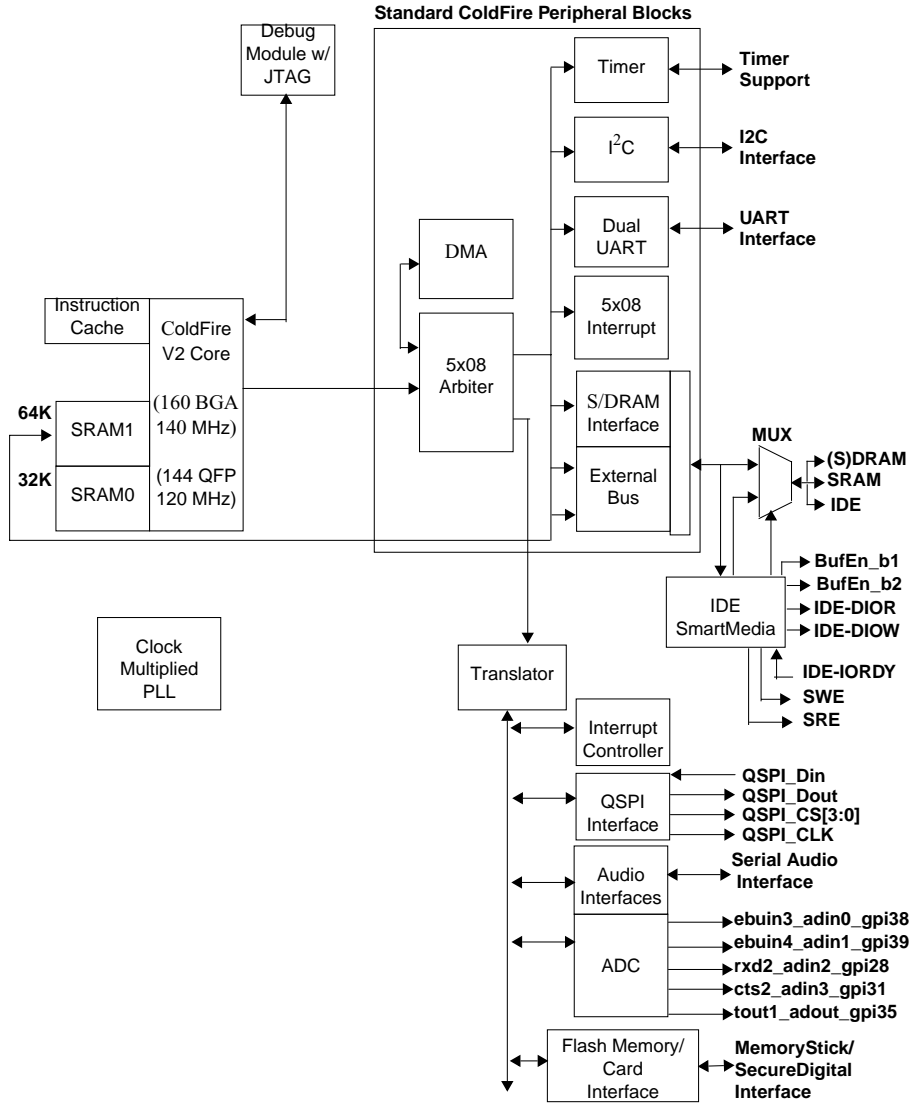

Figure 1. MCF5249 Block Diagram

Freescale Semiconductor, Inc.

MCF5249 Features: Details

1.3 MCF5249 Features: Details

The primary features of the MCF5249 integrated processor include the following:

- ColdFire V2 Processor Core operating at 140 MHz
 - Clock-doubled Version 2 microprocessor core
 - 32-bit internal data bus, 16 bit external data bus
 - 16 user-visible, 32-bit general-purpose registers
 - Supervisor/user modes for system protection
 - Vector base register to relocate exception-vector table
 - Optimized for high-level language constructs
- DMA controller
 - Four fully programmable channels: Two dedicated to the audio interface module and two dedicated to the UART module (External requests are not supported.)
 - Supports dual- and single-address transfers with 32-bit data capability
 - Two address pointers that can increment or remain constant
 - 16-/24-bit transfer counter
 - Operand packing and unpacking support
 - Auto-alignment transfers supported for efficient block movement
 - Supports bursting and cycle stealing
 - All channels support memory to memory transfers
 - Interrupt capability
 - Provides two clock cycle internal access
- Enhanced Multiply-accumulator Unit
 - Single-cycle multiply-accumulate operations for 32 x 32 bit and 16 x 16 bit operands
 - Support for signed, unsigned, integer, and fixed-point fractional input operands
 - Four 48-bit accumulators to allow the use of a 40-bit product
 - The addition of 8 extension bits to increase the dynamic number range
 - Fast signed and unsigned integer multiplies
- 8-Kbyte Direct Mapped instruction cache
 - Clocked core clock frequency
 - Flush capability
 - Non-blocking cache provides fast access to critical code and data
- 96-Kbyte SRAM
 - Provides one-cycle access to critical code and data
 - Split into two banks, SRAM0 (32K), and SRAM1 (64K)
 - DMA requests to/from internal SRAM1 supported
- Crystal Trim
 - The XTRIM output can be used to trim an external crystal oscillator circuit which would allow lock with an incoming IEC958 or serial audio signal

Freescale Semiconductor, Inc.

MCF5249 Features: Details

- Audio Interfaces
 - IEC958 input and output
 - Four serial Philips IIS/Sony EIAJ interfaces
 - One with input and output, one with output only, two with input only (Three inputs, two outputs)
 - Master and Slave operation
- CD Text Interface
 - Allows the interface of CD subcode (transmitter only)
- Dual Universal Synchronous/Asynchronous Receiver/Transmitter (Dual UART)
 - Full duplex operation
 - Baud-rate generator
 - Modem control signals: clear-to-send (CTS) and request-to-send (RTS)
 - DMA interrupt capability
 - Processor-interrupt capability
- Queued Serial Peripheral Interface (QSPI)
 - Programmable queue to support up to 16 transfers without user intervention
 - Supports transfer sizes of 8 to 16 bits in 1-bit increments
 - Four peripheral chip-select lines for control of up to 15 devices
 - Baud rates from 273 Kbps to 17.5 Mbps at 140MHz
 - Programmable delays before and after transfers
 - Programmable clock phase and polarity
 - Supports wraparound mode for continuous transfers
 - Master mode only
- Dual 16-bit General-purpose Multimode Timers
 - Clock source selectable from external, CPU clock/2 and CPU clock/32.
 - 8-bit programmable prescaler
 - 2 timer inputs and 2 outputs
 - Processor-interrupt capability
 - 14.3 nS resolution with CPU clock at 140MHz
- IDE/ SmartMedia Interface
 - Allows direct connection to an IDE hard drive or other IDE peripheral
- Analog/Digital Converter
 - 12-Bit Resolution
 - 4 Muxed inputs
- Flash Memory Card Interface
 - Allows connection to Sony MemoryStick compatible devices
 - Support SD cards and other types of flash media

Freescale Semiconductor, Inc.

160 MAPBGA Ball Assignments

- Dual I²C Interfaces
 - Interchip bus interface for EEPROMs, LCD controllers, A/D converters, keypads
 - Master and slave modes, support for multiple masters
 - Automatic interrupt generation with programmable level
- System debug support
 - Real-time instruction trace for determining dynamic execution path
 - Background debug mode (BDM) for debug features while halted
 - Debug exception processing capability
 - Real-time debug support
- System Interface
 - Glueless bus interface and DRAMC support for interface to 16-bit for DRAM, SRAM, ROM, FLASH, and I/O devices
 - Two programmable chip-select signals for static memories or peripherals with programmable wait states and port sizes.
 - Two dedicated chip selects for 16-bit wide DRAM/SDRAM.
CS0 is active after reset to provide boot-up from external FLASH/ROM.
 - Two dedicated chip selects (CS2 and CS3) are used for the IDE and/or SmartMedia interface
 - Programmable interrupt controller (low interrupt latency, eight external interrupt requests, programmable autovector generator)
 - 44 programmable general-purpose inputs (for the 160 MAPBGA package)
 - 46 programmable general-purpose outputs (for the 160 MAPBGA package)
 - IEEE 1149.1 Test (JTAG) Module
- Clocking
 - Clock-multiplied PLL, programmable frequency
- 1.8V core, 3.3V I/O
- 160 pin MAPBGA package (qualified at 140 MHz) and 144 pin QFP package (qualified at 120 MHz)

1.4 160 MAPBGA Ball Assignments

The following signals are not available on the 144 QFP package.

NOTE

The 144 QFP part is qualified for 120 MHz operation. The 160 MAPBGA part is qualified for 140 MHz.

Freescale Semiconductor, Inc.**MCF5249 Functional Overview****Table 1. 160 MAPBGA Ball Assignments**

160MAPBGA Ball Number	Function	GPIO
E3	cmd_sdio2	gpio34
G4	sdata0_sdio1	gpio54
H3	RSTO/sdata2_bs2	
K3	A25	gpio8
L4	QSPI_CS1	gpio24
L8	QSPI_CS3	gpio22
N8	SDRAM_CS2	gpio7
P9	EbuOut2	gpo 37
K11	BUFENb2	gpio17
G12	subr	gpio 53
F13	sfsy	gpio 52
F12	rck	gpio 51
E8	SRE	gpio11
B8	lrck3	gpio 45
E7	SWE	gpio12
A7	sclk3	gpio 49

1.5 MCF5249 Functional Overview

This section provides a brief summary of the functional blocks in the MCF5249. For more details refer to the *MCF5249 User's Manual*.

1.5.1 ColdFire V2 Core

The ColdFire processor Version 2 core consists of two independent, decoupled pipeline structures to maximize performance while minimizing core size. The instruction fetch pipeline (IFP) is a two-stage pipeline for prefetching instructions. The prefetched instruction stream is then gated into the two-stage operand execution pipeline (OEP), which decodes the instruction, fetches the required operands, and then executes the required function. Because the IFP and OEP pipelines are decoupled by an instruction buffer that serves as a FIFO queue, the IFP can prefetch instructions in advance of their actual use by the OEP, which minimizes time stalled waiting for instructions. The OEP is implemented in a two-stage pipeline featuring a traditional RISC data path with a dual-read-ported register file feeding an arithmetic/logic unit (ALU).

1.5.2 DMA Controller

The MCF5249 provides four fully programmable DMA channels for quick data transfer. Single and dual address mode is supported with the ability to program bursting and cycle stealing. Data transfer is selectable as 8, 16, 32, or 128-bits. Packing and unpacking is supported.

Freescale Semiconductor, Inc.

MCF5249 Functional Overview

Two internal audio channels and the dual UART can be used with the DMA channels. All channels can perform memory to memory transfers. The DMA controller has a user-selectable, 24- or 16-bit counter and a programmable DMA exception handler.

External requests are not supported.

1.5.3 Enhanced Multiply and Accumulate Module (EMAC)

The integrated EMAC unit provides a common set of DSP operations and enhances the integer multiply instructions in the ColdFire architecture. The EMAC provides functionality in three related areas:

1. Faster signed and unsigned integer multiplies
2. New multiply-accumulate operations supporting signed and unsigned operands
3. New miscellaneous register operations

Multiplies of 16x16 and 32x32 with 48-bit accumulates are supported in addition to a full set of extensions for signed and unsigned integers plus signed, fixed-point fractional input operands. The EMAC has a single-clock issue for 32x32-bit multiplication instructions and implements a four-stage execution pipeline.

1.5.4 Instruction Cache

The instruction cache improves system performance by providing cached instructions to the execution unit in a single clock. The MCF5249 processor uses an 8 Kbyte, direct-mapped instruction cache to achieve 125 MIPS at 140 MHz. The cache is accessed by physical addresses, where each 16-byte line consists of an address tag and a valid bit. The instruction cache also includes a bursting interface for 16-bit and 8-bit port sizes to quickly fill cache lines.

1.5.5 Internal 96-Kbyte SRAM

The 96-Kbyte on-chip SRAM is split over two banks, SRAM0 (64k) and SRAM1 (32K). It provides one clock-cycle access for the ColdFire core. This SRAM can store processor stack and critical code or data segments to maximize performance. Memory in the second bank can be accessed under DMA.

1.5.6 DRAM Controller

The MCF5249 DRAM controller provides a glueless interface for up to two banks of DRAM, each of which can be up to 32 Mbytes. The controller supports a 16-bit data bus. A unique addressing scheme allows for increases in system memory size without rerouting address lines and rewiring boards. The controller operates in page mode, non-page mode, and burst-page mode and supports SDRAMs.

1.5.7 System Interface

The MCF5249 provides a glueless interface to 16-bit port size SRAM, ROM, and peripheral devices with independent programmable control of the assertion and negation of chip-select and write-enable signals.

The MCF5249 also supports bursting ROMs.

1.5.8 External Bus Interface

The bus interface controller transfers information between the ColdFire core or DMA and memory, peripherals, or other devices on the external bus. The external bus interface provides 23 bits of address bus space, a 16-bit data bus, Output Enable, and Read/Write signals. This interface implements an extended synchronous protocol that supports bursting operations.

1.5.9 Serial Audio Interfaces

The MCF5249 digital audio interface provides four serial Philips IIS/Sony EIAJ interfaces. One interface is a 4-pin (1 bit clock, 1 word clock, 1 data in, 1 data out), the other three interfaces are 3-pin (1 bit clock, 1 word clock, 1 data in or out). The serial interfaces have no limit on minimum sampling frequency. Maximum sampling frequency is determined by maximum frequency on bit clock input. This is 1/3 the frequency of the internal system clock.

1.5.10 IEC958 Digital Audio Interfaces

The MCF5249 has two digital audio input interfaces, and one digital audio output interface. There are four digital audio input pins, two digital audio output pins. An internal multiplexer selects one of the four inputs to the digital audio input interface.

There is one digital audio output interface but it has two IEC958 outputs. One output carries the professional “c” channel (Channel Status), and the other carries the consumer “c” channel. All other bits (audio data, user channel bits, validity flag, etc) are identical.

The IEC958 output can take the output from the internal IEC958 generator, or multiplex out one of the four IEC958 inputs.

1.5.11 Audio Bus

The audio interfaces connect to an internal bus that carries all audio data. Each receiver places its received data on the audio bus and each transmitter takes data from the audio bus for transmission. Each transmitter has a source select register.

In addition to the audio interfaces, there are six CPU accessible registers connected to the audio bus. Three of these registers allow data reads from the audio bus and allow selection of the audio source. The other three registers provide a write path to the audio bus and can be selected by transmitters as the audio source. Through these registers, the CPU has access to the audio samples for processing.

Audio can be routed from a receiver to a transmitter without the data being processed by the core so the audio bus can be used as a digital audio data switch. The audio bus can also be used for audio format conversion.

1.5.12 CD-ROM Encoder/Decoder

The MCF5249 is capable of processing CD-ROM sectors in hardware. Processing is compliant with CD-ROM and CD-ROM XA standards.

The CD-ROM decoder performs following functions in hardware:

- Sector sync recognition
- Descrambling of sectors

Freescale Semiconductor, Inc.

MCF5249 Functional Overview

- Verification of the CRC checksum for Mode 1, Mode 2 Form 1, and Mode 2 Form 2 sectors
- Third-layer error correction is not performed

The CD-ROM encoder performs following functions in hardware:

- Sector sync recognition
- Scrambling of sectors
- Insertion of the CRC checksum for Mode 1, Mode 2 Form 1, and Mode 2 Form 2 sectors.
- Third-layer error encoding needs to be done in software. This can use approximately 5–10 MHz of performance for single-speed.

1.5.13 Dual UART Module

Two full-duplex UARTs with independent receive and transmit buffers are in this module. Data formats can be 5, 6, 7, or 8 bits with even, odd, or no parity, and up to 2 stop bits in 1/16 increments. Four-byte receive buffers and two-byte transmit buffers minimize CPU service calls. The Dual UART module also provides several error-detection and maskable-interrupt capabilities. Modem support includes request-to-send (RTS) and clear-to-send (CTS) lines.

The system clock provides the clocking function from a programmable prescaler. You can select full duplex, auto-echo loopback, local loopback, and remote loopback modes. The programmable Dual UARTs can interrupt the CPU on various normal or error-condition events.

1.5.14 Queued Serial Peripheral Interface QSPI

The QSPI module provides a serial peripheral interface with queued transfer capability. It supports up to 16 stacked transfers at a time, making CPU intervention between transfers unnecessary. Transfers of up to 17.5 Mbits/second are possible at a CPU clock of 140 MHz. The QSPI supports master mode operation only.

1.5.15 Timer Module

The timer module includes two general-purpose timers, each of which contains a free-running 16-bit timer for use in any of three modes:

1. Input Capture. This mode captures the timer value with an external event.
2. Output Compare. This mode triggers an external signal or interrupts the CPU when the timer reaches a set value
3. Event Counter. This mode counts external events.

The timer unit has an 8-bit prescaler that allows programming of the clock input frequency, which is derived from the system clock. In addition to the $\div 1$ and $\div 16$ clock derived from the bus clock (CPU clock / 2), the programmable timer-output pins either generate an active-low pulse or toggle the outputs.

1.5.16 IDE and SmartMedia Interfaces

The MCF5249 system bus allows connection of an IDE hard disk drive and SmartMedia flash card with a minimum of external hardware. The external hardware consists of bus buffers for address and data and are intended to reduce the load on the bus and prevent SDRAM and Flash accesses to propagate to the IDE bus. The control signals for the buffers are generated in the MCF5249.

1.5.17 Analog/Digital Converter (ADC)

The four channel ADC is based on the Sigma-Delta concept with 12-bit resolution. The digital portion of the ADC is provided internally. The analog voltage comparator must be provided externally as well as an external integrator circuit (resistor/capacitor) which is driven by the ADC output. A software interrupt is provided when the ADC measurement cycle is complete.

1.5.18 Flash Memory Card Interface

The interface is Sony MemoryStick and SecureDigital compatible. However, there is no hardware support for MagicGate™.

1.5.19 I²C Module

The two-wire I²C bus interface, which is compliant with the Philips I²C bus standard, is a bidirectional serial bus that exchanges data between devices. The I²C bus minimizes the interconnection between devices in the end system and is best suited for applications that need occasional bursts of rapid communication over short distances among several devices. Bus capacitance and the number of unique addresses limit the maximum communication length and the number of devices that can be connected.

1.5.20 Chip-Selects

There are four programmable chip selects on the MCF5249:

- Two programmable chip-select outputs (CS0 and CS1) provide signals that enable glueless connection to external memory and peripheral circuits. The base address, access permissions, and automatic wait-state insertion are programmable with configuration registers. These signals also interface to 16-bit ports.
- Two dedicated chip selects (CS2 and CS3) are used for the IDE and/or SmartMedia interface

CS0 is active after reset to provide boot-up from external FLASH/ROM.

1.5.21 GPIO Interface

A total of 44 General Purpose inputs and 46 General Purpose outputs are available. These are multiplexed with various other signals. Eight of the GPIO inputs have edge sensitive interrupt capability.

1.5.22 Interrupt Controller

The interrupt controller provides user-programmable control of a total of 57 interrupts. There are 49 internal interrupt sources. In addition, there are 8 GPIOs where interrupts can be generated on the rising or falling edge of the pin. All interrupts are autovectored and interrupt levels are programmable.

1.5.23 JTAG

To help with system diagnostics and manufacturing testing, the MCF5249 includes dedicated user-accessible test logic that complies with the IEEE 1149.1A standard for boundary scan testability, often referred to as Joint Test Action Group, or JTAG. For more information, refer to the IEEE 1149.1A standard. Motorola provides BSDL files for JTAG testing.

Freescale Semiconductor, Inc.

General Device Information

1.5.24 System Debug Interface

The ColdFire processor core debug interface supports real-time instruction trace and debug, plus background-debug mode. A background-debug mode (BDM) interface provides system debug.

In real-time instruction trace, four status lines provide information on processor activity in real time (PST pins). A four-bit wide debug data bus (DDATA) displays operand data and change-of-flow addresses, which helps track the machine's dynamic execution path.

1.5.25 Crystal and On-chip PLL

Typically, an external 16.92 MHz or 33.86 MHz clock input is used for CD R/W applications, while an 11.2896 MHz clock is more practical for Portable CD player applications. However, the on-chip programmable PLL, which generates the processor clock, allows the use of almost any low frequency external clock (5-35 MHz).

Two clock outputs (MCLK1 and MCLK2) are provided for use as Audio Master Clock. The output frequencies of both outputs are programmable to F_{xtal} , $F_{xtal}/2$, $F_{xtal}/3$, and $F_{xtal}/4$. The $F_{xtal}/3$ option is only available when the 33.86 MHz crystal is connected.

The MCF5249 supports VCO operation of the oscillator by means of a 16-bit pulse density modulation output. Using this mode, it is possible to lock the oscillator to the frequency of an incoming IEC958 or IIS signal. The maximum trim depends on the type and design of the oscillator. Typically a trim of +/- 100 ppm can be achieved with a crystal oscillator and over +/- 1000 ppm with an LC oscillator.

1.6 General Device Information

The MCF5249 is available in a 160-pin MAP BGA package, or a 144-pin QFP package.

1.7 Documentation

Table 2 lists the documents that provide a complete description of the MCF5249 and are required to design properly with the part. Documentation is available from a local Motorola distributor, a Motorola semiconductor sales office, a Motorola Literature Distribution Center, or through the Motorola world-wide web address at <http://www.motorola.com/semiconductors>.

Table 2. MCF5249 Documentation

Document Name	Order Number
<i>ColdFire Family Programmer's Reference Manual</i>	CFPRM/D
<i>Version 2/2M ColdFire Core Processor User's Manual</i>	COLDFIRE2UM/D
<i>Version 2/2M ColdFire Core Processor User's Manual Addendum</i>	COLDFIRE2UMAD/D
<i>MCF5249 User's Manual</i>	MCF5249UM/D

Freescale Semiconductor, Inc.

HOW TO REACH US:

USA/EUROPE/LOCATIONS NOT LISTED:

Motorola Literature Distribution
P.O. Box 5405, Denver, Colorado 80217
1-303-675-2140 or 1-800-441-2447

JAPAN:

Motorola Japan Ltd.
SPS, Technical Information Center
3-20-1, Minami-Azabu Minato-ku
Tokyo 106-8573 Japan
81-3-3440-3569

ASIA/PACIFIC:

Motorola Semiconductors H.K. Ltd.
Silicon Harbour Centre, 2 Dai King Street
Tai Po Industrial Estate, Tai Po, N.T., Hong Kong
852-26668334

TECHNICAL INFORMATION CENTER:

1-800-521-6274

HOME PAGE:

<http://www.motorola.com/semiconductors>

DOCUMENT COMMENTS:

FAX (512) 933-2625
Attn: TECD Applications Engineering

Information in this document is provided solely to enable system and software implementers to use Motorola products. There are no express or implied copyright licenses granted hereunder to design or fabricate any integrated circuits or integrated circuits based on the information in this document.

Motorola reserves the right to make changes without further notice to any products herein.

Motorola makes no warranty, representation or guarantee regarding the suitability of its products for any particular purpose, nor does Motorola assume any liability arising out of the application or use of any product or circuit, and specifically disclaims any and all liability, including without limitation consequential or incidental damages. "Typical" parameters which may be provided in Motorola data sheets and/or specifications can and do vary in different applications and actual performance may vary over time. All operating parameters, including "Typicals" must be validated for each customer application by customer's technical experts. Motorola does not convey any license under its patent rights nor the rights of others. Motorola products are not designed, intended, or authorized for use as components in systems intended for surgical implant into the body, or other applications intended to support or sustain life, or for any other application in which the failure of the Motorola product could create a situation where personal injury or death may occur. Should Buyer purchase or use Motorola products for any such unintended or unauthorized application, Buyer shall indemnify and hold Motorola and its officers, employees, subsidiaries, affiliates, and distributors harmless against all claims, costs, damages, and expenses, and reasonable attorney fees arising out of, directly or indirectly, any claim of personal injury or death associated with such unintended or unauthorized use, even if such claim alleges that Motorola was negligent regarding the design or manufacture of the part.



Motorola and the Stylized M Logo are registered in the U.S. Patent and Trademark Office. digital dna is a trademark of Motorola, Inc. All other product or service names are the property of their respective owners. Motorola, Inc. is an Equal Opportunity/Affirmative Action Employer.

© Motorola, Inc. 2002

MCF5249PB/D

**For More Information On This Product,
Go to: www.freescale.com**