

# MCF5271 Integrated Microprocessor Hardware Specification

32-bit Embedded Controller Division

The MCF5271 family is a highly integrated implementation of the ColdFire<sup>®</sup> family of reduced instruction set computing (RISC) microprocessors. This document describes pertinent features and functions of the MCF5271 family. The MCF5271 family includes the MCF5271 and MCF5270 microprocessors. The differences between these parts are summarized below in [Table 1](#). This document is written from the perspective of the MCF5271 and unless otherwise noted, the information applies also to the MCF5270.

The MCF5271 family combines low cost with high integration on the popular version 2 ColdFire core with over 96 (Dhrystone 2.1) MIPS at 100MHz. Positioned for applications requiring a cost-sensitive 32-bit solution, the MCF5271 family features a 10/100 Ethernet MAC and optional hardware encryption to ensure the application can be connected and protected. In addition, the MCF5271 family features an enhanced Multiply Accumulate Unit (eMAC), large on-chip memory (64 Kbytes SRAM, 8 Kbytes configurable cache), and a 32-bit SDR SDRAM memory controller.

## Table of Contents

1	MCF5271 Family Configurations .....	2
2	Block Diagram .....	2
3	Features .....	4
4	Signal Descriptions.....	12
5	Modes of Operation .....	16
6	Design Recommendations .....	19
7	Mechanicals/Pinouts and Part Numbers .....	27
8	Preliminary Electrical Characteristics .....	32
9	Documentation .....	55

Technical Data

© Freescale Semiconductor, Inc., 2004. All rights reserved.



# 1 MCF5271 Family Configurations

Table 1. MCF5271 Family Configurations

Module	5270	5271
ColdFire V2 Core with EMAC and Hardware Divide	x	x
System Clock	100 MHz	
Performance (Dhrystone/2.1 MIPS)	96	
Instruction/Data Cache	8 Kbytes	
Static RAM (SRAM)	64 Kbytes	
Interrupt Controllers (INTC)	2	2
Edge Port Module (EPORT)	x	x
External Interface Module (EIM)	x	x
4-channel Direct-Memory Access (DMA)	x	x
SDRAM Controller	x	x
Fast Ethernet Controller (FEC)	x	x
Hardware Encryption	—	x
Watchdog Timer (WDT)	x	x
Four Periodic Interrupt Timers (PIT)	x	x
32-bit DMA Timers	4	4
QSPI	x	x
UART(s)	3	3
I <sup>2</sup> C	x	x
General Purpose I/O Module (GPIO)	x	x
JTAG - IEEE 1149.1 Test Access Port	x	x
Package	160 QFP, 196 MAPBGA	160 QFP, 196 MAPBGA

## 2 Block Diagram

The superset device in the MCF5271 family comes in a 196 mold array plastic ball grid array (MAPBGA) package. [Figure 1](#) shows a top-level block diagram of the MCF5271.

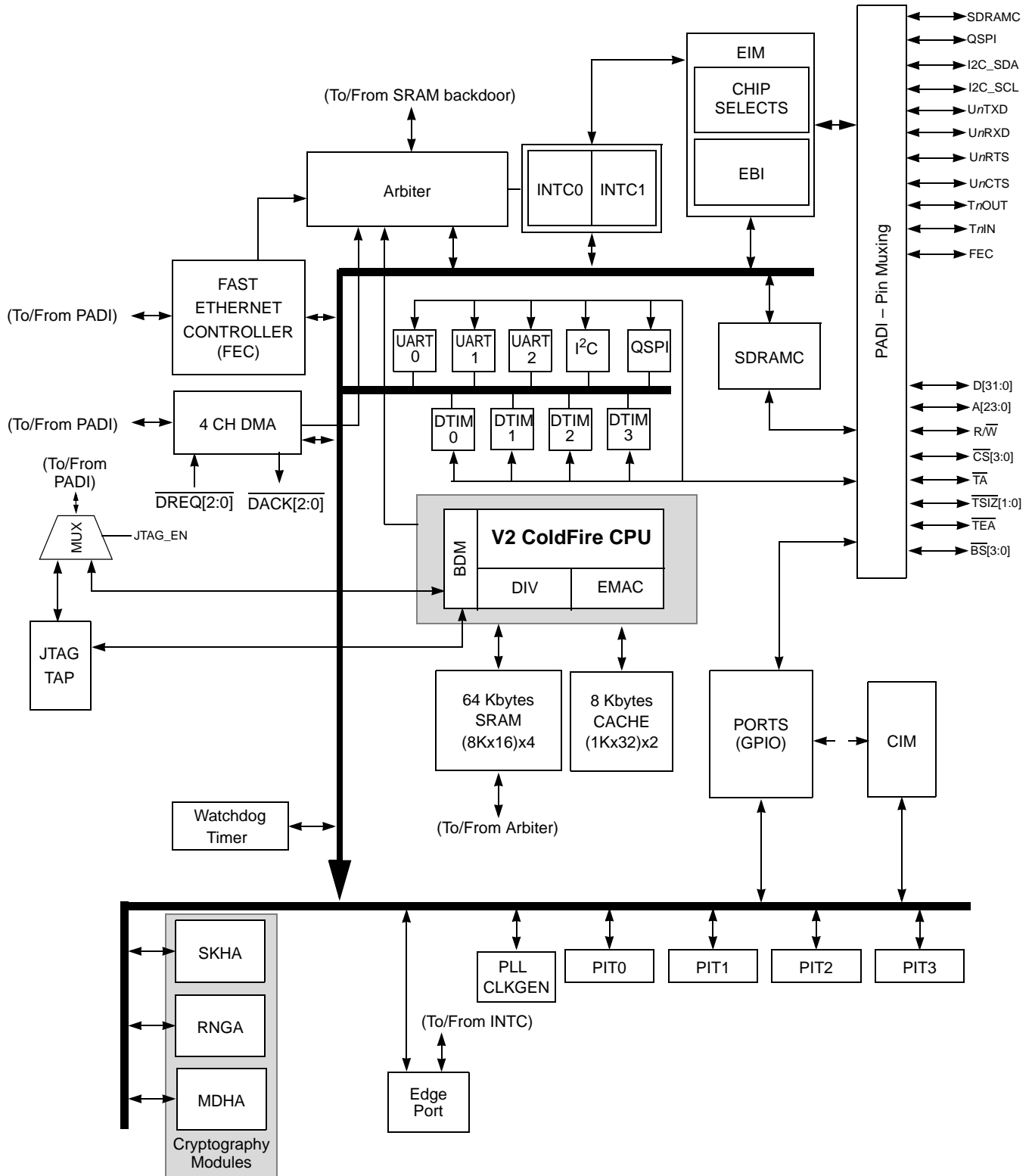

Figure 1. MCF5271 Block Diagram

## 3 Features

This document contains information on a new product. Specifications and information herein are subject to change without notice.

### 3.1 Feature Overview

- Version 2 ColdFire variable-length RISC processor core
  - Static operation
  - 32-bit address and data path on-chip
  - Processor core runs at twice the bus frequency
  - Sixteen general-purpose 32-bit data and address registers
  - Implements the ColdFire Instruction Set Architecture, ISA\_A, with extensions to support the user stack pointer register, and 4 new instructions for improved bit processing
  - Enhanced Multiply-Accumulate (EMAC) unit with four 48-bit accumulators to support 32-bit signal processing algorithms
  - Illegal instruction decode that allows for 68K emulation support
- System debug support
  - Real time trace for determining dynamic execution path
  - Background debug mode (BDM) for in-circuit debugging
  - Real time debug support, with two user-visible hardware breakpoint registers (PC and address with optional data) that can be configured into a 1- or 2-level trigger
- On-chip memories
  - 8-Kbyte cache, configurable as instruction-only, data-only, or split I-/D-cache
  - 64-Kbyte dual-ported SRAM on CPU internal bus, accessible by core and non-core bus masters (e.g., DMA, FEC)
- Fast Ethernet Controller (FEC)
  - 10 BaseT capability, half duplex or full duplex
  - 100 BaseT capability, half duplex or full duplex
  - On-chip transmit and receive FIFOs
  - Built-in dedicated DMA controller
  - Memory-based flexible descriptor rings
  - Media independent interface (MII) to external transceiver (PHY)
- Three Universal Asynchronous Receiver Transmitters (UARTs)
  - 16-bit divider for clock generation
  - Interrupt control logic
  - Maskable interrupts
  - DMA support

- Data formats can be 5, 6, 7 or 8 bits with even, odd or no parity
- Up to 2 stop bits in 1/16 increments
- Error-detection capabilities
- Modem support includes request-to-send ( $\overline{\text{URTS}}$ ) and clear-to-send ( $\overline{\text{UCTS}}$ ) lines for two UARTs
- Transmit and receive FIFO buffers
- I<sup>2</sup>C Module
  - Interchip bus interface for EEPROMs, LCD controllers, A/D converters, and keypads
  - Fully compatible with industry-standard I<sup>2</sup>C bus
  - Master or slave modes support multiple masters
  - Automatic interrupt generation with programmable level
- Queued Serial Peripheral Interface (QSPI)
  - Full-duplex, three-wire synchronous transfers
  - Up to four chip selects available
  - Master mode operation only
  - Programmable master bit rates
  - Up to 16 pre-programmed transfers
- Four 32-bit DMA Timers
  - 20-ns resolution at 50 MHz
  - Programmable sources for clock input, including an external clock option
  - Programmable prescaler
  - Input-capture capability with programmable trigger edge on input pin
  - Output-compare with programmable mode for the output pin
  - Free run and restart modes
  - Maskable interrupts on input capture or reference-compare
  - DMA trigger capability on input capture or reference-compare
- Four Periodic Interrupt Timers (PITs)
  - 16-bit counter
  - Selectable as free running or count down
- Software Watchdog Timer
  - 16-bit counter
  - Low power mode support
- Frequency Modulated Phase Locked Loop (PLL)
  - Crystal or external oscillator reference
  - 8 to 25 MHz reference frequency for normal PLL mode

## Features

- 24 to 50 MHz oscillator reference frequency for 1:1 mode
- Separate clock output pin
- Interrupt Controllers (x2)
  - Support for up to 41 interrupt sources organized as follows: 34 fully-programmable interrupt sources and 7 fixed-level external interrupt sources
- Unique vector number for each interrupt source
- Ability to mask any individual interrupt source or all interrupt sources (global mask-all)
- Support for hardware and software interrupt acknowledge (IACK) cycles
- Combinatorial path to provide wake-up from low power modes
- DMA Controller
  - Four fully programmable channels
  - Dual-address and single-address transfer support with 8-, 16- and 32-bit data capability along with support for 16-byte (4 x 32-bit) burst transfers
  - Source/destination address pointers that can increment or remain constant
  - 24-bit byte transfer counter per channel
  - Auto-alignment transfers supported for efficient block movement
  - Bursting and cycle steal support
  - Software-programmable connections between the 12 DMA requesters in the UARTs (3), 32-bit timers (4), plus external logic (4), and the four DMA channels (4)
- External Bus Interface
  - Glueless connections to external memory devices (e.g., SRAM, Flash, ROM, etc.)
  - SDRAM controller supports 8-, 16-, and 32-bit wide memory devices
  - Support for n-1-1-1 burst fetches from page mode Flash
  - Glueless interface to SRAM devices with or without byte strobe inputs
  - Programmable wait state generator
  - 32-bit bidirectional data bus
  - 24-bit address bus
  - Up to eight chip selects available
  - Byte/write enables (byte strobes)
  - Ability to boot from external memories that are 8, 16, or 32 bits wide
- Chip Configuration Module (CCM)
  - System configuration during reset
  - Selects one of four clock modes
  - Sets boot device and its data port width
  - Configures output pad drive strength
  - Unique part identification number and part revision number

- Reset
  - Separate reset in and reset out signals
  - Six sources of reset: Power-on reset (POR), External, Software, Watchdog, PLL loss of clock, PLL loss of lock
  - Status flag indication of source of last reset
- General Purpose I/O interface
  - Up to 61 bits of general purpose I/O
  - Bit manipulation supported via set/clear functions
  - Unused peripheral pins may be used as extra GPIO
- JTAG support for system level board testing

## 3.2 V2 Core Overview

The processor core is comprised of two separate pipelines that are decoupled by an instruction buffer. The two-stage Instruction Fetch Pipeline (IFP) is responsible for instruction-address generation and instruction fetch. The instruction buffer is a first-in-first-out (FIFO) buffer that holds prefetched instructions awaiting execution in the Operand Execution Pipeline (OEP). The OEP includes two pipeline stages. The first stage decodes instructions and selects operands (DSOC); the second stage (AGEX) performs instruction execution and calculates operand effective addresses, if needed.

The V2 core implements the ColdFire Instruction Set Architecture Revision A with added support for a separate user stack pointer register and four new instructions to assist in bit processing. Additionally, the MCF5271 core includes the enhanced multiply-accumulate unit (EMAC) for improved signal processing capabilities. The EMAC implements a 4-stage execution pipeline, optimized for 32 x 32 bit operations, with support for four 48-bit accumulators. Supported operands include 16- and 32-bit signed and unsigned integers as well as signed fractional operands as well as a complete set of instructions to process these data types. The EMAC provides superb support for execution of DSP operations within the context of a single processor at a minimal hardware cost.

## 3.3 Debug Module

The ColdFire processor core debug interface is provided to support system debugging in conjunction with low-cost debug and emulator development tools. Through a standard debug interface, users can access real-time trace and debug information. This allows the processor and system to be debugged at full speed without the need for costly in-circuit emulators. The debug interface is a superset of the BDM interface provided on Freescale's 683xx family of parts.

The on-chip breakpoint resources include a total of 6 programmable registers—a set of address registers (with two 32-bit registers), a set of data registers (with a 32-bit data register plus a 32-bit data mask register), and one 32-bit PC register plus a 32-bit PC mask register. These registers can be accessed through the dedicated debug serial communication channel or from the processor's supervisor mode programming model. The breakpoint registers can be configured to generate triggers by combining the address, data, and PC conditions in a variety of single or dual-level definitions. The trigger event can be programmed to generate a processor halt or initiate a debug interrupt exception.

To support program trace, the Version 2 debug module provides processor status (PST[3:0]) and debug data (DDATA[3:0]) ports. These buses and the PSTCLK output provide execution status, captured operand data, and branch target addresses defining processor activity at the CPU's clock rate.

## 3.4 JTAG

The MCF5271 supports circuit board test strategies based on the Test Technology Committee of IEEE and the Joint Test Action Group (JTAG). The test logic includes a test access port (TAP) consisting of a 16-state controller, an instruction register, and three test registers (a 1-bit bypass register, a 330-bit boundary-scan register, and a 32-bit ID register). The boundary scan register links the device's pins into one shift register. Test logic, implemented using static logic design, is independent of the device system logic.

The MCF5271 implementation can do the following:

- Perform boundary-scan operations to test circuit board electrical continuity
- Sample MCF5271 system pins during operation and transparently shift out the result in the boundary scan register
- Bypass the MCF5271 for a given circuit board test by effectively reducing the boundary-scan register to a single bit
- Disable the output drive to pins during circuit-board testing
- Drive output pins to stable levels

## 3.5 On-chip Memories

### 3.5.1 Cache

The 8-Kbyte cache can be configured into one of three possible organizations: an 8-Kbyte instruction cache, an 8-Kbyte data cache or a split 4-Kbyte instruction/4-Kbyte data cache. The configuration is software-programmable by control bits within the privileged Cache Configuration Register (CACR). In all configurations, the cache is a direct-mapped single-cycle memory, organized as 512 lines, each containing 16 bytes of data. The memories consist of a 512-entry tag array (containing addresses and control bits) and a 8-Kbyte data array, organized as 2048 x 32 bits.

If the desired address is mapped into the cache memory, the output of the data array is driven onto the ColdFire core's local data bus, completing the access in a single cycle. If the data is not mapped into the tag memory, a cache miss occurs and the processor core initiates a 16-byte line-sized fetch. The cache module includes a 16-byte line fill buffer used as temporary storage during miss processing. For all data cache configurations, the memory operates in write-through mode and all operand writes generate an external bus cycle.

### 3.5.2 SRAM

The SRAM module provides a general-purpose 64-Kbyte memory block that the ColdFire core can access in a single cycle. The location of the memory block can be set to any 64-Kbyte boundary within the 4-Gbyte address space. The memory is ideal for storing critical code or data structures, for use as the



system stack, or for storing FEC data buffers. Because the SRAM module is physically connected to the processor's high-speed local bus, it can quickly service core-initiated accesses or memory-referencing commands from the debug module.

The SRAM module is also accessible by the DMA and FEC non-core bus masters. The dual-ported nature of the SRAM makes it ideal for implementing applications with double-buffer schemes, where the processor and a DMA device operate in alternate regions of the SRAM to maximize system performance. As an example, system performance can be increased significantly if Ethernet packets are moved from the FEC into the SRAM (rather than external memory) prior to any processing.

## 3.6 Fast Ethernet Controller (FEC)

The MCF5271's integrated Fast Ethernet Controller (FEC) performs the full set of IEEE 802.3/Ethernet CSMA/CD media access control and channel interface functions. The FEC supports connection and functionality for the 10/100 Mbps 802.3 media independent interface (MII). It requires an external transceiver (PHY) to complete the interface to the media.

## 3.7 UARTs

The MCF5271 contains three full-duplex UARTs that function independently. The three UARTs can be clocked by the system bus clock, eliminating the need for an externally supplied clock. They can use DMA requests on transmit-ready and receive-ready as well as interrupt requests for servicing. Flow control is only available on two of the UARTs.

## 3.8 I<sup>2</sup>C Bus

The I<sup>2</sup>C bus is a two-wire, bidirectional serial bus that provides a simple, efficient method of data exchange, minimizing the interconnection between devices. This bus is suitable for applications requiring occasional communications over a short distance between many devices.

## 3.9 QSPI

The queued serial peripheral interface module provides a high-speed synchronous serial peripheral interface with queued transfer capability. It allows up to 16 transfers to be queued at once, eliminating CPU intervention between transfers.

## 3.10 Cryptography

The superset device, MCF5271, incorporates small, fast, dedicated hardware accelerators for random number generation, message digest and hashing, and the DES, 3DES, and AES block cipher functions allowing for the implementation of common Internet security protocol cryptography operations with performance well in excess of software-only algorithms.

## 3.11 DMA Timers (DTIM0-DTIM3)

There are four independent, DMA-transfer-generating 32-bit timers (DTIM[3:0]) on the MCF5271. Each timer module incorporates a 32-bit timer with a separate register set for configuration and control. The timers can be configured to operate from the system clock or from an external clock source using one of the DTIN $n$  signals. If the system clock is selected, it can be divided by 16 or 1. The input clock is further divided by a user-programmable 8-bit prescaler which clocks the actual timer counter register (TCR $n$ ). Each of these timers can be configured for input capture or reference compare mode. By configuring the internal registers, each timer may be configured to assert an external signal, generate an interrupt on a particular event or cause a DMA transfer.

## 3.12 Periodic Interrupt Timers (PIT0-PIT3)

The four periodic interrupt timers (PIT[3:0]) are 16-bit timers that provide precise interrupts at regular intervals with minimal processor intervention. Each timer can either count down from the value written in its PIT modulus register, or it can be a free-running down-counter.

## 3.13 Software Watchdog Timer

The watchdog timer is a 16-bit timer that facilitates recovery from runaway code. The watchdog counter is a free-running down-counter that generates a reset on underflow. To prevent a reset, software must periodically restart the countdown.

## 3.14 Clock Module and Phase Locked Loop (PLL)

The clock module contains a crystal oscillator (OSC), frequency modulated phase-locked loop (PLL), reduced frequency divider (RFD), status/control registers, and control logic. To improve noise immunity, the PLL and OSC have their own power supply inputs, VDDPLL and VSSPLL. All other circuits are powered by the normal supply pins, VDD and VSS.

## 3.15 Interrupt Controllers (INTC0/INTC1)

There are two interrupt controllers on the MCF5271, each of which can support up to 63 interrupt sources each for a total of 126. Each interrupt controller is organized as 7 levels with 9 interrupt sources per level. Each interrupt source has a unique interrupt vector, and 56 of the 63 sources of a given controller provide a programmable level [1-7] and priority within the level.

## 3.16 DMA Controller

The Direct Memory Access (DMA) Controller Module provides an efficient way to move blocks of data with minimal processor interaction. The DMA module provides four channels (DMA0-DMA3) that allow byte, word, longword or 16-byte burst line transfers. These transfers are triggered by software explicitly setting a DCR $n$ [START] bit. Other sources include the DMA timer, external sources via the  $\overline{\text{DREQ}}$  signal,

and UARTs. The DMA controller supports single or dual address to off-chip devices or dual address to on-chip devices.

### 3.17 External Interface Module (EIM)

The external bus interface handles the transfer of information between the core and memory, peripherals, or other processing elements in the external address space. Features have been added to support external Flash modules, for secondary wait states on reads and writes, and a signal to support Active-Low Address Valid (a signal on most Flash memories).

Programmable chip-select outputs provide signals to enable external memory and peripheral circuits, providing all handshaking and timing signals for automatic wait-state insertion and data bus sizing.

Base memory address and block size are programmable, with some restrictions. For example, the starting address must be on a boundary that is a multiple of the block size. Each chip select can be configured to provide read and write enable signals suitable for use with most popular static RAMs and peripherals. Data bus width (8-bit, 16-bit, or 32-bit) is programmable on all chip selects, and further decoding is available for protection from user mode access or read-only access.

### 3.18 SDRAM Controller

The SDRAM controller provides all required signals for glueless interfacing to a variety of JEDEC-compliant SDRAM devices.  $\overline{\text{SD\_SRAS}}/\overline{\text{SD\_SCAS}}$  address multiplexing is software configurable for different page sizes. To maintain refresh capability without conflicting with concurrent accesses on the address and data buses,  $\overline{\text{SD\_RAS}}$ ,  $\overline{\text{SD\_SCAS}}$ ,  $\overline{\text{SD\_WE}}$ ,  $\overline{\text{SD\_CS}}[1:0]$  and  $\overline{\text{SD\_CKE}}$  are dedicated SDRAM signals.

### 3.19 Reset

The reset controller is provided to determine the cause of reset, assert the appropriate reset signals to the system, and keep track of what caused the last reset. The power management registers for the internal low-voltage detect (LVD) circuit are implemented in the reset module. There are six sources of reset:

- External
- Power-on reset (POR)
- Watchdog timer
- Phase locked-loop (PLL) loss of lock
- PLL loss of clock
- Software

External reset on the  $\overline{\text{RSTOUT}}$  pin is software-assertable independent of chip reset state. There are also software-readable status flags indicating the cause of the last reset.

## 3.20 GPIO

Unused bus interface and peripheral pins on the MCF5271 can be used as discrete general-purpose inputs and outputs. These are managed by a dedicated GPIO module that logically groups all pins into ports located within a contiguous block of memory-mapped control registers.

All of the pins associated with the external bus interface may be used for several different functions. Their primary function is to provide an external memory interface to access off-chip resources. When not used for this, all of the pins may be used as general-purpose digital I/O pins. In some cases, the pin function is set by the operating mode, and the alternate pin functions are not supported.

The digital I/O pins on the MCF5271 are grouped into 8-bit ports. Some ports do not use all eight bits. Each port has registers that configure, monitor, and control the port pins.

## 4 Signal Descriptions

This section describes signals that connect off chip, including a table of signal properties. For a more detailed discussion of the MCF5271 signals, consult the *MCF5235 Reference Manual* (MCF5235RM).

### 4.1 Signal Properties

Table 2 lists all of the signals grouped by function. The “Dir” column is the direction for the primary function of the pin. Refer to [Section 7, “Mechanicals/Pinouts and Part Numbers,”](#) for package diagrams.

#### NOTE

In this table and throughout this document a single signal within a group is designated without square brackets (i.e., A24), while designations for multiple signals within a group use brackets (i.e., A[23:21]) and is meant to include all signals within the two bracketed numbers when these numbers are separated by a colon.

#### NOTE

The primary functionality of a pin is not necessarily its default functionality. Pins that are muxed with GPIO will default to their GPIO functionality.

**Table 2. MCF5270 and MCF5271 Signal Information and Muxing**

Signal Name	GPIO	Alternate 1	Alternate 2	Dir. <sup>1</sup>	MCF5270 MCF5271 160 QFP	MCF5270 MCF5271 196 MAPBGA
<b>Reset</b>						
RESET	—	—	—	I	83	N13
RSTOUT	—	—	—	O	82	P13
<b>Clock</b>						
EXTAL	—	—	—	I	86	M14
XTAL	—	—	—	O	85	N14

Table 2. MCF5270 and MCF5271 Signal Information and Muxing (continued)

Signal Name	GPIO	Alternate 1	Alternate 2	Dir. <sup>1</sup>	MCF5270 MCF5271 160 QFP	MCF5270 MCF5271 196 MAPBGA
CLKOUT	—	—	—	O	89	K14
<b>Mode Selection</b>						
CLKMOD[1:0]	—	—	—	I	20,21	G5,H5
$\overline{RCON}$	—	—	—	I	79	K10
<b>External Memory Interface and Ports</b>						
A[23:21]	PADDR[7:5]	$\overline{CS}$ [6:4]	—	O	126, 125, 124	B11, C11, D11
A[20:0]	—	—	—	O	123:115, 112:106, 102:98	A12, B12, C12, A13, B13, B14, C13, C14, D12, D13, D14, E11, E12, E13, E14, F12, F13, F14, G11, G12, G13
D[31:16]	—	—	—	O	22:30, 33:39	G1, G2, H1, H2, H3, H4, J1, J2, J3, J4, K1, K2, K3, K4, L1, L2
D[15:8]	PDATAH[7:0]	—	—	O	42:49	M1, N1, M2, N2, P2, L3, M3, N3
D[7:0]	PDATAL[7:0]	—	—	O	50:52, 56:60	P3, M4, N4, P4, L5, M5, N5, P5
$\overline{BS}$ [3:0]	PBS[7:4]	$\overline{CAS}$ [3:0]	—	O	143:140	B6, C6, D7, C7
$\overline{OE}$	PBUSCTL7	—	—	O	62	N6
$\overline{TA}$	PBUSCTL6	—	—	I	96	H11
$\overline{TEA}$	PBUSCTL5	$\overline{DREQ1}$	—	I	—	J14
R/ $\overline{W}$	PBUSCTL4	—	—	O	95	J13
TSIZ1	PBUSCTL3	$\overline{DACK1}$	—	O	—	P6
TSIZ0	PBUSCTL2	$\overline{DACK0}$	—	O	—	P7
$\overline{TS}$	PBUSCTL1	$\overline{DACK2}$	—	O	97	H13
$\overline{TIP}$	PBUSCTL0	DREQ0	—	O	—	H12
<b>Chip Selects</b>						
$\overline{CS}$ [7:4]	PCS[7:4]	—	—	O	—	B9, A10, C10, A11
$\overline{CS}$ [3:2]	PCS[3:2]	SD_CS[1:0]	—	O	132,131	A9, C9
$\overline{CS1}$	PCS1	—	—	O	130	B10
$\overline{CS0}$	—	—	—	O	129	D10
<b>SDRAM Controller</b>						

Table 2. MCF5270 and MCF5271 Signal Information and Muxing (continued)

Signal Name	GPIO	Alternate 1	Alternate 2	Dir. <sup>1</sup>	MCF5270 MCF5271 160 QFP	MCF5270 MCF5271 196 MAPBGA
SD_WE	PSDRAM5	—	—	O	92	K13
SD_SCAS	PSDRAM4	—	—	O	91	K12
SD_SRAS	PSDRAM3	—	—	O	90	K11
SD_CKE	PSDRAM2	—	—	O	139	E8
SD_CS[1:0]	PSDRAM[1:0]	—	—	O	—	L12, L13
<b>External Interrupts Port</b>						
IRQ[7:3]	PIRQ[7:3]	—	—	I	IRQ7=63 IRQ4=64	N7, M7, L7, P8, N8
IRQ2	PIRQ2	DREQ2	—	I	—	M8
IRQ1	PIRQ1	—	—	I	65	L8
<b>FEC</b>						
EMDC	PFECI2C3	I2C_SCL	U2TXD	O	151	D4
EMDIO	PFECI2C2	I2C_SDA	U2RXD	I/O	150	D5
ECOL	—	—	—	I	9	E2
ECRS	—	—	—	I	8	E1
ERXCLK	—	—	—	I	7	D1
ERXDV	—	—	—	I	6	D2
ERXD[3:0]	—	—	—	I	5:2	D3, C1, C2, B1
ERXER	—	—	—	O	159	B2
ETXCLK	—	—	—	I	158	A2
ETXEN	—	—	—	I	157	C3
ETXER	—	—	—	O	156	B3
ETXD[3:0]	—	—	—	O	155:152	A3, A4, C4, B4
<b>I<sup>2</sup>C</b>						
I2C_SDA	PFECI2C1	—	—	I/O	—	J12
I2C_SCL	PFECI2C0	—	—	I/O	—	J11
<b>DMA</b>						
DACK[2:0] and DREQ[2:0] do not have a dedicated bond pads. Please refer to the following pins for muxing: TS and DT2OUT for DACK2, TSIZ1 and DT1OUT for DACK1, TSIZ0 and DT0OUT for DACK0, IRQ2 and DT2IN for DREQ2, TEA and DT1IN for DREQ1, and TIP and DT0IN for DREQ0.					—	—
<b>QSPI</b>						
QSPI_CS1	PQSPI4	SD_CKE	—	O	—	B7

Table 2. MCF5270 and MCF5271 Signal Information and Muxing (continued)

Signal Name	GPIO	Alternate 1	Alternate 2	Dir. <sup>1</sup>	MCF5270 MCF5271 160 QFP	MCF5270 MCF5271 196 MAPBGA
QSPI_CS0	PQSPI3	—	—	O	146	A6
QSPI_CLK	PQSPI2	I2C_SCL	—	O	147	C5
QSPI_DIN	PQSPI1	I2C_SDA	—	I	148	B5
QSPI_DOUT	PQSPI0	—	—	O	149	A5
<b>UARTs</b>						
U2TXD	PUARTH1	—	—	O	—	A8
U2RXD	PUARTH0	—	—	I	—	A7
$\overline{U1CTS}$	PUARTL7	$\overline{U2CTS}$	—	I	136	B8
$\overline{U1RTS}$	PUARTL6	$\overline{U2RTS}$	—	O	135	C8
U1TXD	PUARTL5	—	—	O	133	D9
U1RXD	PUARTL4	—	—	I	134	D8
$\overline{U0CTS}$	PUARTL3	—	—	I	12	F3
$\overline{U0RTS}$	PUARTL2	—	—	O	15	G3
U0TXD	PUARTL1	—	—	O	14	F1
U0RXD	PUARTL0	—	—	I	13	F2
<b>DMA Timers</b>						
DT3IN	PTIMER7	$\overline{U2CTS}$	—	I	—	H14
DT3OUT	PTIMER6	$\overline{U2RTS}$	—	O	—	G14
DT2IN	PTIMER5	$\overline{DREQ2}$	DT2OUT	I	66	M9
DT2OUT	PTIMER4	$\overline{DACK2}$	—	O	—	L9
DT1IN	PTIMER3	$\overline{DREQ1}$	DT1OUT	I	61	L6
DT1OUT	PTIMER2	$\overline{DACK1}$	—	O	—	M6
DT0IN	PTIMER1	$\overline{DREQ0}$	—	I	10	E4
DT0OUT	PTIMER0	$\overline{DACK0}$	—	O	11	F4
<b>BDM/JTAG<sup>2</sup></b>						
DSCLK	—	TRST	—	O	70	N9
PSTCLK	—	TCLK	—	O	68	P9
$\overline{BKPT}$	—	TMS	—	O	71	P10
DSI	—	TDI	—	I	73	M10
DSO	—	TDO	—	O	72	N10
JTAG_EN	—	—	—	I	78	K9
DDATA[3:0]	—	—	—	O	—	M12, N12, P12, L11

**Table 2. MCF5270 and MCF5271 Signal Information and Muxing (continued)**

Signal Name	GPIO	Alternate 1	Alternate 2	Dir. <sup>1</sup>	MCF5270 MCF5271 160 QFP	MCF5270 MCF5271 196 MAPBGA
PST[3:0]	—	—	—	O	77:74	M11, N11, P11, L10
<b>Test</b>						
TEST	—	—	—	I	19	F5
PLL_TEST	—	—	—	I	—	
<b>Power Supplies</b>						
VDDPLL	—	—	—	I	87	M13
VSSPLL	—	—	—	I	84	L14
OVDD	—	—	—	I	1, 18, 32, 41, 55, 69, 81, 94, 105, 114, 128, 138, 145	E5, E7, E10, F7, F9, G6, G8, H7, H8, H9, J6, J8, J10, K5, K6, K8
VSS	—	—	—	I	17, 31, 40, 54, 67, 80, 88, 93, 104, 113, 127, 137, 144, 160	A1, A14, E6, E9, F6, F8, F10, G7, G9, H6, J5, J7, J9, K7, P1, P14
VDD	—	—	—	I	16, 53, 103	D6, F11, G4, L4

NOTES:

<sup>1</sup> Refers to pin's primary function. All pins which are configurable for GPIO have a pullup enabled in GPIO mode with the exception of PBUSCTL[7], PBUSCTL[4:0], PADDR, PBS, PSDRAM.

<sup>2</sup> If JTAG\_EN is asserted, these pins default to Alternate 1 (JTAG) functionality. The GPIO module is not responsible for assigning these pins.

## 5 Modes of Operation

### 5.1 Chip Configuration Mode—Device Operating Options

- Chip operating mode:
  - Master mode
- Boot device/size:
  - External device boot
    - 32-bit
    - 16-bit (Default)
    - 8-bit
- Output pad strength:



- Partial drive strength (Default)
- Full drive strength
- Clock mode:
  - Normal PLL with external crystal
  - Normal PLL with external clock
  - 1:1 PLL Mode
  - External oscillator mode (no PLL)
- Chip Select Configuration:
  - PADDR[7:5] configured as chip select(s) and/or address line(s)
    - PADDR[7:5] configured as A23-A21 (default)
    - PADDR configured as  $\overline{\text{CS}}_6$ , PADDR[6:5] as A22-A21
    - PADDR[7:6] configured as  $\overline{\text{CS}}[6:5]$ , PADDR5 as A21
    - PADDR[7:5] configured as  $\overline{\text{CS}}[6:4]$

### 5.1.1 Chip Configuration Pins

Table 3. Configuration Pin Descriptions

Pin	Chip Configuration Function	Pin State/Meaning	Comments
$\overline{\text{RCON}}$	Chip configuration enable	1 Disabled 0 Enabled	Active low: if asserted, then all configuration pins must be driven appropriately for desired operation
D16	Select chip operating mode	1 Master 0 Reserved	
D20, D19	Select external boot device data port size	00,11 External (32-bit) 10 External (8-bit) 01 External (16-bit)	Value read defaults to 32-bit
D21	Select output pad drive strength	1 Full 0 Partial	
CLKMOD1, CLKMOD0	Select clock mode	00 External clock mode (no PLL) 01 1:1 PLL mode 10 Normal PLL with external clock reference 11 Normal PLL with crystal clock reference	VDDPLL must be supplied if a PLL mode is selected

**Table 3. Configuration Pin Descriptions (continued)**

Pin	Chip Configuration Function	Pin State/Meaning	Comments
D25, D24	Select chip select / address line	00 PADDR[7:5] configured as A23-A21 (default) 10 PADDR7 configured as $\overline{CS}6$ , PADDR[6:5] as A22-A21 01 PADDR[7:6] configured as $\overline{CS}[6:5]$ , PADDR5 as A21 11 PADDR[7:5] configured as $\overline{CS}[6:4]$	
JTAG_EN	Selects BDM or JTAG mode	0 BDM mode 1 JTAG mode	

## 5.2 Low Power Modes

The following features are available to support applications which require low power.

- Four modes of operation:
  - RUN
  - WAIT
  - DOZE
  - STOP
- Ability to shut down most peripherals independently.
- Ability to shut down the external CLKOUT pin.

There are four modes of operation: RUN, WAIT, DOZE, and STOP. The system enters a low power mode when the user programs the low power bits (LPMD) in the LPCR (Low Power Control Register) in the CIM before the CPU core executes a STOP instruction. This idles the CPU with no cycles active. The LPMD bits indicate to the system and clock controller to power down and stop the clocks appropriately. During STOP mode, the system clock is stopped low.

A wakeup event is required to exit a low power mode and return back to RUN mode. Wakeup events consist of any of the following conditions. See the following sections for more details.

1. Any type of reset.
2. Assertion of the  $\overline{BKPT}$  pin to request entry into Debug mode.
3. Debug request bit in the BDM control register to request entry into debug mode.
4. Any valid interrupt request.

### 5.2.1 RUN Mode

RUN mode is the normal system operating mode. Current consumption in this mode is related directly to the frequency chosen for the system clock.

## 5.2.2 WAIT Mode

WAIT mode is intended to be used to stop only the CPU core and memory clocks until a wakeup event is detected. In this mode, peripherals may be programmed to continue operating and can generate interrupts, which cause the CPU core to exit from WAIT mode.

## 5.2.3 DOZE Mode

DOZE mode affects the CPU core in the same manner as WAIT mode, but with a different code on the CIM LPMD bits, which are monitored by the peripherals. Each peripheral defines individual operational characteristics in DOZE mode. Peripherals which continue to run and have the capability of producing interrupts may cause the CPU to exit the DOZE mode and return to the RUN mode. Peripherals which are stopped will restart operation on exit from DOZE mode as defined for each peripheral.

## 5.2.4 STOP Mode

STOP mode affects the CPU core in the same manner as the WAIT and DOZE modes, but with a different code on the CCM LPMD bits. In this mode, all clocks to the system are stopped and the peripherals cease operation.

STOP mode must be entered in a controlled manner to ensure that any current operation is properly terminated. When exiting STOP mode, most peripherals retain their pre-stop status and resume operation.

## 5.2.5 Peripheral Shut Down

Most peripherals may be disabled by software in order to cease internal clock generation and remain in a static state. Each peripheral has its own specific disabling sequence (refer to each peripheral description for further details). A peripheral may be disabled at anytime and will remain disabled during any low power mode of operation.

# 6 Design Recommendations

## 6.1 Layout

- Use a 4-layer printed circuit board with the VDD and GND pins connected directly to the power and ground planes for the MCF5271.
- See application note AN1259 System Design and Layout Techniques for Noise Reduction in processor-Based Systems.
- Match the PC layout trace width and routing to match trace length to operating frequency and board impedance. Add termination (series or therein) to the traces to dampen reflections. Increase the PCB impedance (if possible) keeping the trace lengths balanced and short. Then do cross-talk analysis to separate traces with significant parallelism or are otherwise "noisy". Use 6 mils trace and separation. Clocks get extra separation and more precise balancing.

## 6.2 Power Supply

- 33  $\mu\text{F}$ , .1  $\mu\text{F}$  and .01  $\mu\text{F}$  across each power supply

## 6.3 Decoupling

- Place the decoupling caps as close to the pins as possible, but they can be outside the footprint of the package.
- .1  $\mu\text{F}$  and .01  $\mu\text{F}$  at each supply input

## 6.4 Buffering

- Use bus buffers on all data/address lines for all off-board accesses and for all on-board accesses when excessive loading is expected. See [Section 8, “Preliminary Electrical Characteristics.”](#)

## 6.5 Pull-up Recommendations

- Use external pull-up resistors on unused inputs. See pin table.

## 6.6 Clocking Recommendations

- Use a multi-layer board with a separate ground plane.
- Place the crystal and all other associated components as close to the EXTAL and XTAL (oscillator pins) as possible.
- Do not run a high frequency trace around crystal circuit.
- Ensure that the ground for the bypass capacitors is connected to a solid ground trace.
- Tie the ground trace to the ground pin nearest EXTAL and XTAL. This prevents large loop currents in the vicinity of the crystal.
- Tie the ground pin to the most solid ground in the system.
- Do not connect the trace that connects the oscillator and the ground plane to any other circuit element. This tends to make the oscillator unstable.
- Tie XTAL to ground when an external oscillator is clocking the device.

## 6.7 Interface Recommendations

### 6.7.1 SDRAM Controller

#### 6.7.1.1 SDRAM Controller Signals in Synchronous Mode

[Table 4](#) shows the behavior of SDRAM signals in synchronous mode.

**Table 4. Synchronous DRAM Signal Connections**

Signal	Description
$\overline{\text{SD\_SRAS}}$	Synchronous row address strobe. Indicates a valid SDRAM row address is present and can be latched by the SDRAM. $\overline{\text{SD\_SRAS}}$ should be connected to the corresponding SDRAM $\overline{\text{SD\_SRAS}}$ . Do not confuse $\overline{\text{SD\_SRAS}}$ with the DRAM controller's $\overline{\text{SD\_CS}}[1:0]$ , which should not be interfaced to the SDRAM $\overline{\text{SD\_SRAS}}$ signals.
$\overline{\text{SD\_SCAS}}$	Synchronous column address strobe. Indicates a valid column address is present and can be latched by the SDRAM. $\overline{\text{SD\_SCAS}}$ should be connected to the corresponding signal labeled $\overline{\text{SD\_SCAS}}$ on the SDRAM.
$\overline{\text{DRAMW}}$	DRAM read/write. Asserted for write operations and negated for read operations.
$\overline{\text{SD\_CS}}[1:0]$	Row address strobe. Select each memory block of SDRAMs connected to the MCF5271. One $\overline{\text{SD\_CS}}$ signal selects one SDRAM block and connects to the corresponding $\overline{\text{CS}}$ signals.
$\overline{\text{SD\_CKE}}$	Synchronous DRAM clock enable. Connected directly to the CKE (clock enable) signal of SDRAMs. Enables and disables the clock internal to SDRAM. When CKE is low, memory can enter a power-down mode where operations are suspended or they can enter self-refresh mode. $\overline{\text{SD\_CKE}}$ functionality is controlled by DCR[COC]. For designs using external multiplexing, setting COC allows $\overline{\text{SD\_CKE}}$ to provide command-bit functionality.
$\overline{\text{BS}}[3:0]$	Column address strobe. For synchronous operation, $\overline{\text{BS}}[3:0]$ function as byte enables to the SDRAMs. They connect to the DQM signals (or mask qualifiers) of the SDRAMs.
CLKOUT	Bus clock output. Connects to the CLK input of SDRAMs.

### 6.7.1.2 Address Multiplexing

Table 5 shows the generic address multiplexing scheme for SDRAM configurations. All possible address connection configurations can be derived from this table.

**Table 5. Generic Address Multiplexing Scheme**

Address Pin	Row Address	Column Address	Notes Related to Port Sizes
17	17	0	8-bit port only
16	16	1	8- and 16-bit ports only
15	15	2	
14	14	3	
13	13	4	
12	12	5	
11	11	6	
10	10	7	
9	9	8	
17	17	16	32-bit port only
18	18	17	16-bit port only or 32-bit port with only 8 column address lines
19	19	18	16-bit port only when at least 9 column address lines are used
20	20	19	

**Table 5. Generic Address Multiplexing Scheme (continued)**

Address Pin	Row Address	Column Address	Notes Related to Port Sizes
21	21	20	
22	22	21	
23	23	22	
24	24	23	
25	25	24	

The following tables provide a more comprehensive, step-by-step way to determine the correct address line connections for interfacing the MCF5271 to SDRAM. To use the tables, find the one that corresponds to the number of column address lines on the SDRAM and to the port size as seen by the MCF5271, which is not necessarily the SDRAM port size. For example, if two 1M x 16-bit SDRAMs together form a 2M x 32-bit memory, the port size is 32 bits. Most SDRAMs likely have fewer address lines than are shown in the tables, so follow only the connections shown until all SDRAM address lines are connected.

**Table 6. MCF5271 to SDRAM Interface (8-Bit Port, 9-Column Address Lines)**

MCF5271 Pins	A17	A16	A15	A14	A13	A12	A11	A10	A9	A18	A19	A20	A21	A22	A23	A24	A25	A26	A27	A28	A29	A30	A31
Row	17	16	15	14	13	12	11	10	9	18	19	20	21	22	23	24	25	26	27	28	29	30	31
Column	0	1	2	3	4	5	6	7	8														
SDRAM Pins	A0	A1	A2	A3	A4	A5	A6	A7	A8	A9	A10	A11	A12	A13	A14	A15	A16	A17	A18	A19	A20	A21	A22

**Table 7. MCF5271MCF5271 to SDRAM Interface (8-Bit Port,10-Column Address Lines)**

MCF5271 Pins	A17	A16	A15	A14	A13	A12	A11	A10	A9	A19	A20	A21	A22	A23	A24	A25	A26	A27	A28	A29	A30	A31
Row	17	16	15	14	13	12	11	10	9	19	20	21	22	23	24	25	26	27	28	29	30	31
Column	0	1	2	3	4	5	6	7	8	18												
SDRAM Pins	A0	A1	A2	A3	A4	A5	A6	A7	A8	A9	A10	A11	A12	A13	A14	A15	A16	A17	A18	A19	A20	A21

**Table 8. MCF5271MCF5271 to SDRAM Interface (8-Bit Port,11-Column Address Lines)**

MCF5271 Pins	A17	A16	A15	A14	A13	A12	A11	A10	A9	A19	A21	A22	A23	A24	A25	A26	A27	A28	A29	A30	A31
Row	17	16	15	14	13	12	11	10	9	19	21	22	23	24	25	26	27	28	29	30	31
Column	0	1	2	3	4	5	6	7	8	18	20										
SDRAM Pins	A0	A1	A2	A3	A4	A5	A6	A7	A8	A9	A10	A11	A12	A13	A14	A15	A16	A17	A18	A19	A20

**Table 9. MCF5271MCF5271 to SDRAM Interface (8-Bit Port,12-Column Address Lines)**

MCF5271 Pins	A17	A16	A15	A14	A13	A12	A11	A10	A9	A19	A21	A23	A24	A25	A26	A27	A28	A29	A30	A31
Row	17	16	15	14	13	12	11	10	9	19	21	23	24	25	26	27	28	29	30	31
Column	0	1	2	3	4	5	6	7	8	18	20	22								
SDRAM Pins	A0	A1	A2	A3	A4	A5	A6	A7	A8	A9	A10	A11	A12	A13	A14	A15	A16	A17	A18	A19

**Table 10. MCF5271MCF5271 to SDRAM Interface (8-Bit Port,13-Column Address Lines)**

MCF5271 Pins	A17	A16	A15	A14	A13	A12	A11	A10	A9	A19	A21	A23	A25	A26	A27	A28	A29	A30	A31
Row	17	16	15	14	13	12	11	10	9	19	21	23	25	26	27	28	29	30	31
Column	0	1	2	3	4	5	6	7	8	18	20	22	24						
SDRAM Pins	A0	A1	A2	A3	A4	A5	A6	A7	A8	A9	A10	A11	A12	A13	A14	A15	A16	A17	A18

**Table 11. MCF5271MCF5271 to SDRAM Interface (16-Bit Port, 8-Column Address Lines)**

MCF5271 Pins	A16	A15	A14	A13	A12	A11	A10	A9	A17	A18	A19	A20	A21	A22	A23	A24	A25	A26	A27	A28	A29	A30	A31
Row	16	15	14	13	12	11	10	9	17	18	19	20	21	22	23	24	25	26	27	28	29	30	31
Column	1	2	3	4	5	6	7	8															
SDRAM Pins	A0	A1	A2	A3	A4	A5	A6	A7	A8	A9	A10	A11	A12	A13	A14	A15	A16	A17	A18	A19	A20	A21	A22

**Table 12. MCF5271MCF5271 to SDRAM Interface (16-Bit Port, 9-Column Address Lines)**

MCF5271 Pins	A16	A15	A14	A13	A12	A11	A10	A9	A18	A19	A20	A21	A22	A23	A24	A25	A26	A27	A28	A29	A30	A31
Row	16	15	14	13	12	11	10	9	18	19	20	21	22	23	24	25	26	27	28	29	30	31
Column	1	2	3	4	5	6	7	8	17													
SDRAM Pins	A0	A1	A2	A3	A4	A5	A6	A7	A8	A9	A10	A11	A12	A13	A14	A15	A16	A17	A18	A19	A20	A21

**Table 13. MCF5271MCF5271 to SDRAM Interface (16-Bit Port, 10-Column Address Lines)**

MCF5271 Pins	A16	A15	A14	A13	A12	A11	A10	A9	A18	A20	A21	A22	A23	A24	A25	A26	A27	A28	A29	A30	A31	
Row	16	15	14	13	12	11	10	9	18	20	21	22	23	24	25	26	27	28	29	30	31	
Column	1	2	3	4	5	6	7	8	17	19												
SDRAM Pins	A0	A1	A2	A3	A4	A5	A6	A7	A8	A9	A10	A11	A12	A13	A14	A15	A16	A17	A18	A19	A20	

## Design Recommendations

**Table 14. MCF5271MCF5271 to SDRAM Interface (16-Bit Port, 11-Column Address Lines)**

MCF5271 Pins	A16	A15	A14	A13	A12	A11	A10	A9	A18	A20	A22	A23	A24	A25	A26	A27	A28	A29	A30	A31
Row	16	15	14	13	12	11	10	9	18	20	22	23	24	25	26	27	28	29	30	31
Column	1	2	3	4	5	6	7	8	17	19	21									
SDRAM Pins	A0	A1	A2	A3	A4	A5	A6	A7	A8	A9	A10	A11	A12	A13	A14	A15	A16	A17	A18	A19

**Table 15. MCF5271MCF5271 to SDRAM Interface (16-Bit Port, 12-Column Address Lines)**

MCF5271 Pins	A16	A15	A14	A13	A12	A11	A10	A9	A18	A20	A22	A24	A25	A26	A27	A28	A29	A30	A31	
Row	16	15	14	13	12	11	10	9	18	20	22	24	25	26	27	28	29	30	31	
Column	1	2	3	4	5	6	7	8	17	19	21	23								
SDRAM Pins	A0	A1	A2	A3	A4	A5	A6	A7	A8	A9	A10	A11	A12	A13	A14	A15	A16	A17	A18	

**Table 16. MCF5271MCF5271 to SDRAM Interface (16-Bit Port, 13-Column-Address Lines)**

MCF5271 Pins	A16	A15	A14	A13	A12	A11	A10	A9	A18	A20	A22	A24	A26	A27	A28	A29	A30	A31	
Row	16	15	14	13	12	11	10	9	18	20	22	24	26	27	28	29	30	31	
Column	1	2	3	4	5	6	7	8	17	19	21	23	25						
SDRAM Pins	A0	A1	A2	A3	A4	A5	A6	A7	A8	A9	A10	A11	A12	A13	A14	A15	A16	A17	

**Table 17. MCF5271MCF5271 to SDRAM Interface (32-Bit Port, 8-Column Address Lines)**

MCF5271 Pins	A15	A14	A13	A12	A11	A10	A9	A17	A18	A19	A20	A21	A22	A23	A24	A25	A26	A27	A28	A29	A30	A31
Row	15	14	13	12	11	10	9	17	18	19	20	21	22	23	24	25	26	27	28	29	30	31
Column	2	3	4	5	6	7	8	16														
SDRAM Pins	A0	A1	A2	A3	A4	A5	A6	A7	A8	A9	A10	A11	A12	A13	A14	A15	A16	A17	A18	A19	A20	A21

**Table 18. MCF5271MCF5271 to SDRAM Interface (32-Bit Port, 9-Column Address Lines)**

MCF5271 Pins	A15	A14	A13	A12	A11	A10	A9	A17	A19	A20	A21	A22	A23	A24	A25	A26	A27	A28	A29	A30	A31	
Row	15	14	13	12	11	10	9	17	19	20	21	22	23	24	25	26	27	28	29	30	31	
Column	2	3	4	5	6	7	8	16	18													
SDRAM Pins	A0	A1	A2	A3	A4	A5	A6	A7	A8	A9	A10	A11	A12	A13	A14	A15	A16	A17	A18	A19	A20	



**Table 19. MCF5271MCF5271 to SDRAM Interface (32-Bit Port, 10-Column Address Lines)**

MCF5271 Pins	A15	A14	A13	A12	A11	A10	A9	A17	A19	A21	A22	A23	A24	A25	A26	A27	A28	A29	A30	A31
Row	15	14	13	12	11	10	9	17	19	21	22	23	24	25	26	27	28	29	30	31
Column	2	3	4	5	6	7	8	16	18	20										
SDRAM Pins	A0	A1	A2	A3	A4	A5	A6	A7	A8	A9	A10	A11	A12	A13	A14	A15	A16	A17	A18	A19

**Table 20. MCF5271MCF5271 to SDRAM Interface (32-Bit Port, 11-Column Address Lines)**

MCF5271 Pins	A15	A14	A13	A12	A11	A10	A9	A17	A19	A21	A23	A24	A25	A26	A27	A28	A29	A30	A31	
Row	15	14	13	12	11	10	9	17	19	21	23	24	25	26	27	28	29	30	31	
Column	2	3	4	5	6	7	8	16	18	20	22									
SDRAM Pins	A0	A1	A2	A3	A4	A5	A6	A7	A8	A9	A10	A11	A12	A13	A14	A15	A16	A17	A18	

**Table 21. MCF5271MCF5271 to SDRAM Interface (32-Bit Port, 12-Column Address Lines)**

MCF5271 Pins	A15	A14	A13	A12	A11	A10	A9	A17	A19	A21	A23	A25	A26	A27	A28	A29	A30	A31		
Row	15	14	13	12	11	10	9	17	19	21	23	25	26	27	28	29	30	31		
Column	2	3	4	5	6	7	8	16	18	20	22	24								
SDRAM Pins	A0	A1	A2	A3	A4	A5	A6	A7	A8	A9	A10	A11	A12	A13	A14	A15	A16	A17		

### 6.7.1.3 SDRAM Interfacing Example

The tables in the previous section can be used to configure the interface in the following example. To interface one 2M 32-bit 4 bank SDRAM component (8 columns) to the MCF5271, the connections would be as shown in [Table 22](#).

**Table 22. SDRAM Hardware Connections**

SDRAM Pins	A0	A1	A2	A3	A4	A5	A6	A7	A8	A9	A10 = CMD	BA0	BA1
MCF5271 Pins	A15	A14	A13	A12	A11	A10	A9	A17	A18	A19	A20	A21	A22

### 6.7.2 Ethernet PHY Transceiver Connection

The FEC supports both an MII interface for 10/100 Mbps Ethernet and a seven-wire serial interface for 10 Mbps Ethernet. The interface mode is selected by R\_CNTRL[MII\_MODE]. In MII mode, the 802.3 standard defines and the FEC module supports 18 signals. These are shown in [Table 23](#).

**Table 23. MII Mode**

Signal Description	MCF5271 Pin
Transmit clock	ETXCLK
Transmit enable	ETXEN
Transmit data	ETXD[3:0]
Transmit error	ETXER
Collision	ECOL
Carrier sense	E CRS
Receive clock	ERXCLK
Receive enable	ERXDV
Receive data	ERXD[3:0]
Receive error	ERXER
Management channel clock	EMDC
Management channel serial data	EMDIO

The serial mode interface operates in what is generally referred to as AMD mode. The MCF5271 configuration for seven-wire serial mode connections to the external transceiver are shown in [Table 24](#).

**Table 24. Seven-Wire Mode Configuration**

Signal Description	MCF5271 Pin
Transmit clock	ETXCLK
Transmit enable	ETXEN
Transmit data	ETXD[0]
Collision	ECOL
Receive clock	ERXCLK
Receive enable	ERXDV
Receive data	ERXD[0]
Unused, configure as PB14	ERXER
Unused input, tie to ground	E CRS
Unused, configure as PB[13:11]	ERXD[3:1]
Unused output, ignore	ETXER
Unused, configure as PB[10:8]	ETXD[3:1]
Unused, configure as PB15	EMDC
Input after reset, connect to ground	EMDIO

Refer to the M5271EVB evaluation board user's manual for an example of how to connect an external PHY. Schematics for this board are accessible at the MCF5271 site by navigating to: <http://www.freescale.com>.

### 6.7.3 BDM

Use the BDM interface as shown in the M5271EVB evaluation board user's manual. The schematics for this board are accessible at the MCF5271 site by navigating from: <http://www.freescale.com> following the 32-bit Embedded Processors, 68K/ColdFire, MCF5xxx, MCF5271 and M5271EVB links.

## 7 Mechanicals/Pinouts and Part Numbers

This section contains drawings showing the pinout and the packaging and mechanical characteristics of the MCF5271 devices. See [Table 2](#) for a list the signal names and pin locations for each device.

# 7.1 Pinout—196 MAPBGA

Figure 2 shows a pinout of the MCF5270/71CVMxxx package.

	1	2	3	4	5	6	7	8	9	10	11	12	13	14	
A	VSS	ETXCLK	ETXD3	ETXD2	QSPL_DOUT	QSPL_CS0	U2RXD	U2TXD	$\overline{CS3}$	$\overline{CS6}$	$\overline{CS4}$	A20	A17	VSS	A
B	ERXD0	ERXER	ETXER	ETXD0	QSPL_DIN	$\overline{BS3}$	QSPL_CS1	U1CTS	$\overline{CS7}$	$\overline{CS1}$	A23	A19	A16	A15	B
C	ERXD2	ERXD1	ETXEN	ETXD1	QSCK	$\overline{BS2}$	$\overline{BS0}$	RTS1	$\overline{CS2}$	$\overline{CS5}$	A22	A18	A14	A13	C
D	ERXCLK	ERXDV	ERXD3	EMDC	EMDIO	Core VDD_4	$\overline{BS1}$	U1RXD1	U1TXD	$\overline{CS0}$	A21	A12	A11	A10	D
E	ECRS	ECOL	NC	TIN0	VDD	VSS	VDD	SD_CKE	VSS	VDD	A9	A8	A7	A6	E
F	U0TXD	U0RXD	U0CTS	DTOUT0	TEST	VSS	VDD	VSS	VDD	VSS	Core VDD_3	A5	A4	A3	F
G	Data31	DATA30	U0RTS	Core VDD_1	CLK MOD1	VDD	VSS	VDD	VSS	NC	A2	A1	A0	DTOUT3	G
H	DATA29	DATA28	DATA27	DATA26	CLK MOD0	VSS	VDD	VDD	VDD	NC	$\overline{TA}$	$\overline{TIP}$	$\overline{TS}$	DTIN3	H
J	DATA25	DATA24	DATA23	DATA22	VSS	VDD	VSS	VDD	VSS	VDD	I2C_SCL	I2C_SDA	$\overline{RW}$	$\overline{TEA}$	J
K	DATA21	DATA20	DATA19	DATA18	VDD	VDD	VSS	VDD	JTAG_EN	$\overline{RCON}$	$\overline{SD_RAS}$	$\overline{SD_CAS}$	$\overline{SD_WE}$	CLKOUT	K
L	DATA17	DATA16	DATA10	Core VDD_2	DATA3	DTIN1	$\overline{IRQ5}$	$\overline{IRQ1}$	DTOUT2	PST0	DDATA0	$\overline{SD_CS1}$	$\overline{SD_CS0}$	VSSPLL	L
M	DATA15	DATA13	DATA9	DATA6	DATA2	DTOUT1	$\overline{IRQ6}$	$\overline{IRQ2}$	DTIN2	TD/DSI	PST3	DDATA3	VDDPLL	EXTAL	M
N	DATA14	DATA12	DATA8	DATA5	DATA1	$\overline{OE}$	$\overline{IRQ7}$	$\overline{IRQ3}$	$\overline{TRST}/\overline{DSCLK}$	TD0/DS0	PST2	DDATA2	$\overline{RESET}$	XTAL	N
P	VSS	DATA11	DATA7	DATA4	DATA0	TSIZ1	TSIZ0	$\overline{IRQ4}$	TCLK/PSTCLK	TMS/BKPT	PST1	DDATA1	$\overline{RSTOUT}$	VSS	P
	1	2	3	4	5	6	7	8	9	10	11	12	13	14	

Figure 2. MCF5270/71CVMxxx Pinout (196 MAPBGA)

# 7.2 Package Dimensions—196 MAPBGA

Figure 3 shows MCF5270/71CVM<sub>xxx</sub> package dimensions.

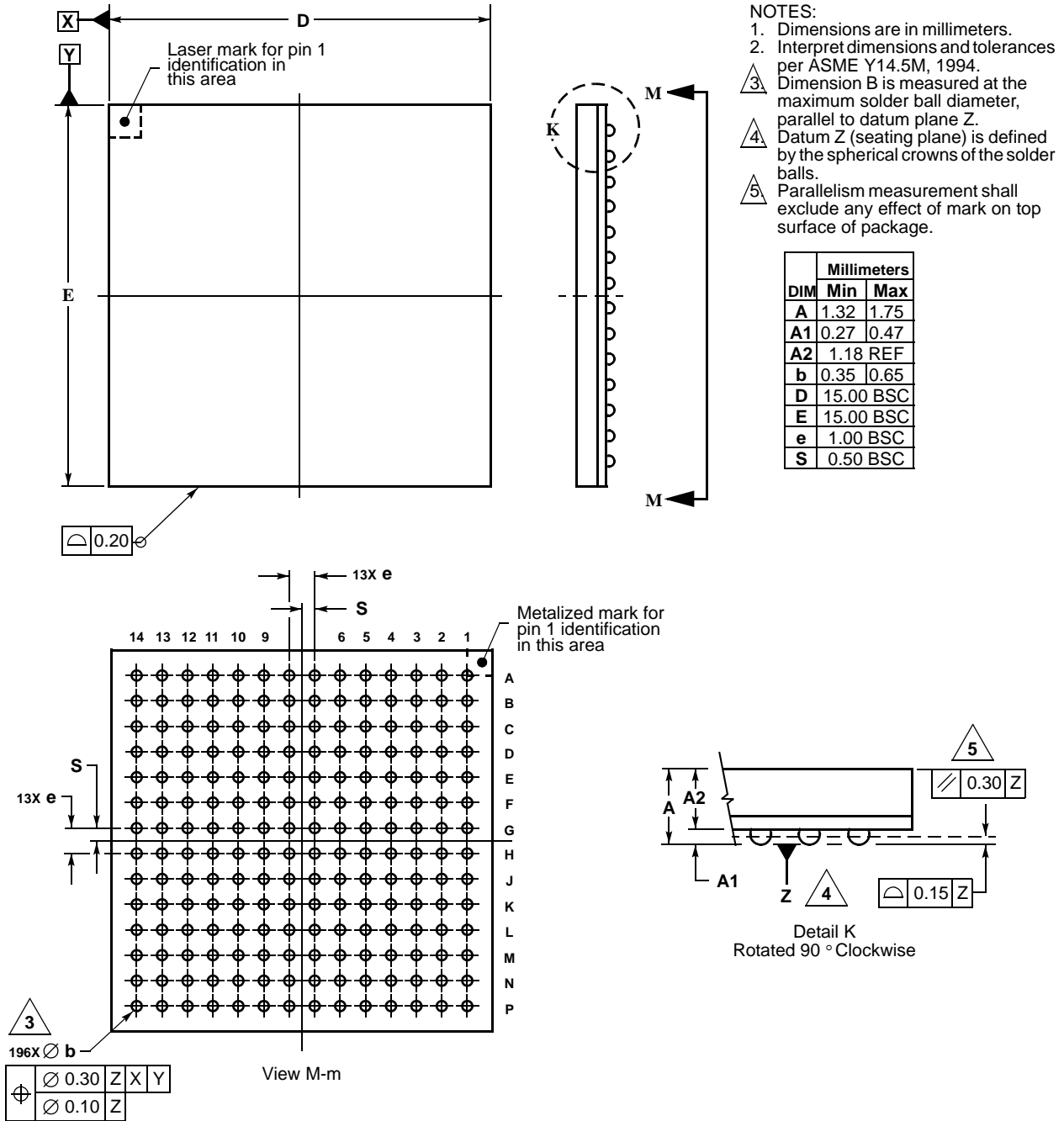

Figure 3. 196 MAPBGA Package Dimensions (Case No. 1128A-01)

# 7.3 Pinout—160 QFP

Figure 4 shows a pinout of the MCF5271CABxxx package.

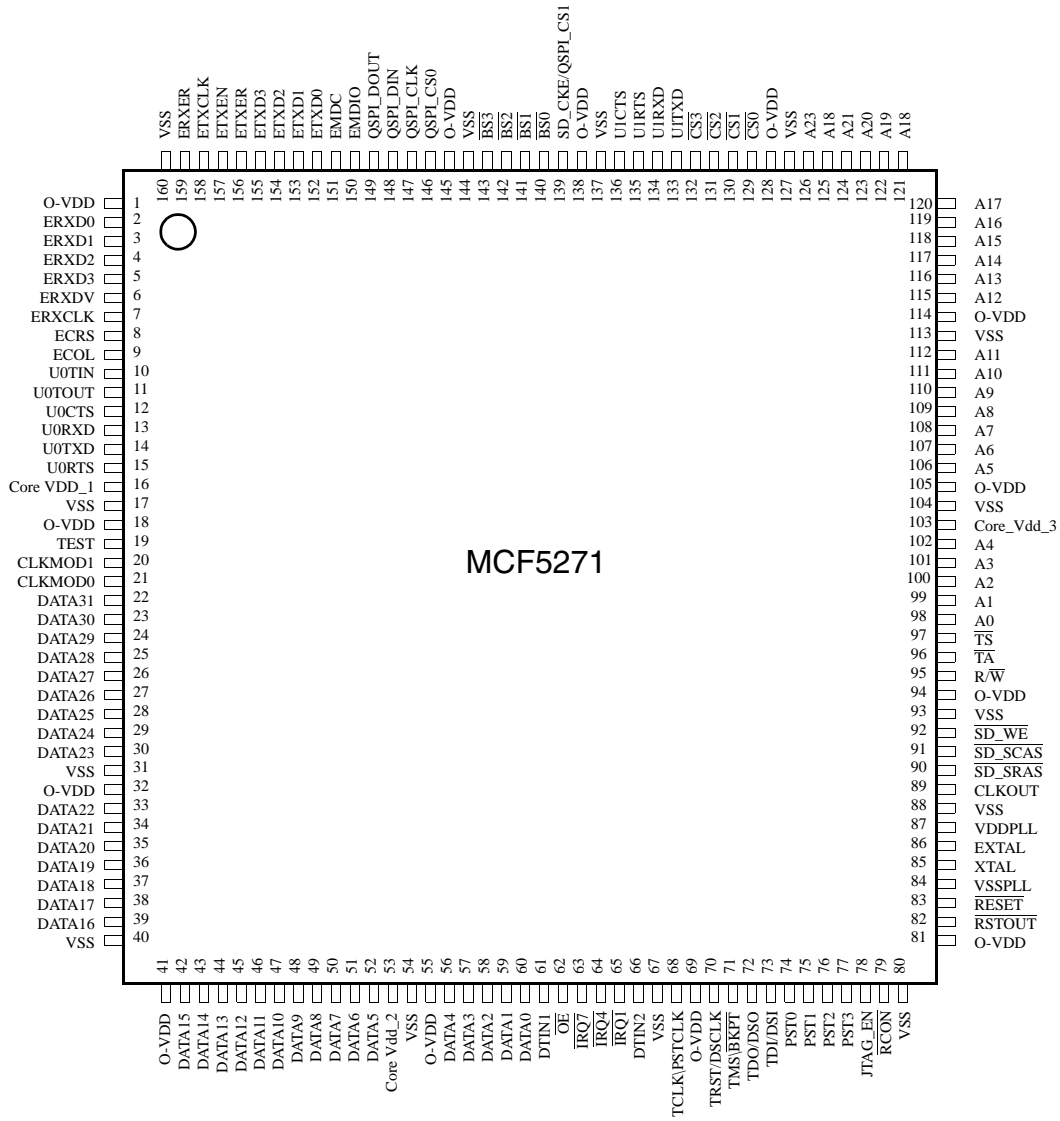
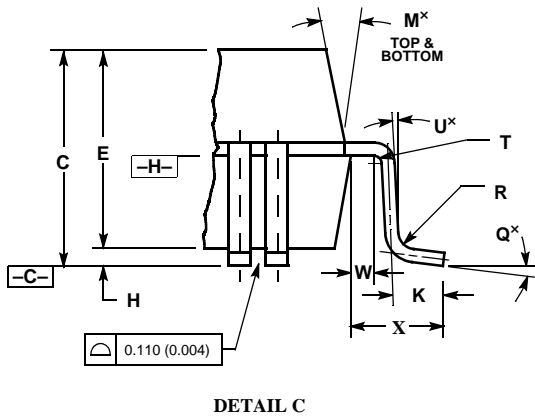
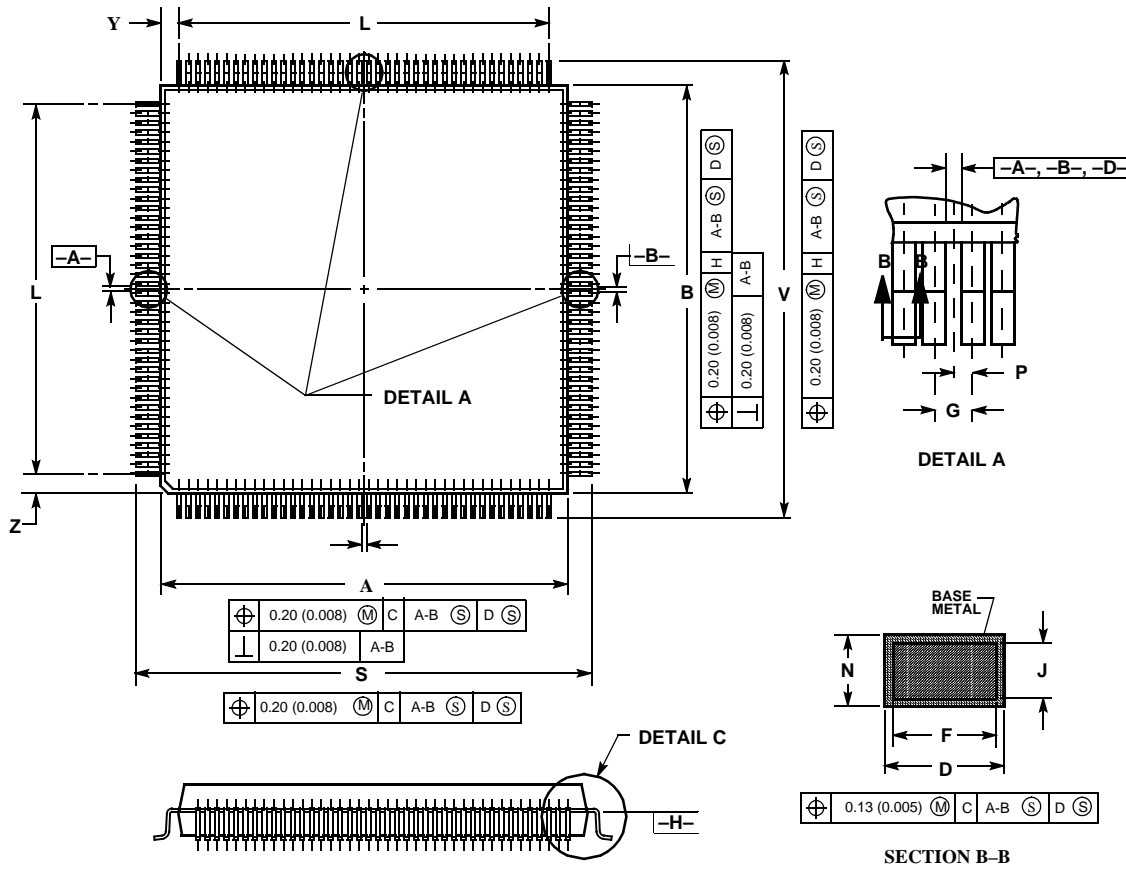

Figure 4. MCF5270/71CABxxx Pinout (160 QFP)

# 7.4 Package Dimensions—160 QFP

Figure 5 shows MCF5270/71CAB80 package dimensions.



- NOTES
1. DIMENSIONING AND TOLERANCING PER ANSI Y14.5M, 1982.
  2. CONTROLLING DIMENSION: MILLIMETER
  3. DATUM PLAN -H- IS LOCATED AT BOTTOM OF LEAD AND IS COINCIDENT WITH THE LEAD WHERE THE LEAD EXITS THE PLASTIC BODY AT THE BOTTOM OF THE PARTING LINE.
  4. DATUMS -A-, -B-, AND -D- TO BE DETERMINED AT DATUM PLANE -H-.
  5. DIMENSIONS S AND V TO BE DETERMINED AT SEATING PLANE -C-.
  6. DIMENSIONS A AND B DO NOT INCLUDE MOLD PROTRUSION. ALLOWABLE PROTRUSION IS 0.25 (0.010) PER SIDE. DIMENSIONS A AND B DO INCLUDE MOLD MISMATCH AND ARE DETERMINED AT DATUM PLANE -H-.
  7. DIMENSION D DOES NOT INCLUDE DAMBAR PROTRUSION. ALLOWABLE DAMBAR PROTRUSION SHALL BE 0.08 (0.003) TOTAL IN EXCESS OF THE D DIMENSION AT MAXIMUM MATERIAL CONDITION. DAMBAR CANNOT BE LOCATED ON THE LOWER RADIUS OR THE FOOT.

DIM	MILLIMETERS		INCHES	
	MIN	MAX	MIN	MAX
A	27.90	28.10	1.098	1.106
B	27.90	28.10	1.098	1.106
C	3.35	3.85	0.132	1.106
D	0.22	0.38	0.009	0.015
E	3.20	3.50	0.126	0.138
F	0.22	0.33	0.009	0.013
G	0.65 BSC		0.026 REF	
H	0.25	0.35	0.010	0.014
J	0.11	0.23	0.004	0.009
K	0.70	0.90	0.028	0.035
L	25.35 BSC		0.998 REF	
M	5°	16°	5°	16°
N	0.11	0.19	0.004	0.007
P	0.325 BSC		0.013 REF	
Q	0°	7°	0°	7°
R	0.13	0.30	0.005	0.012
S	31.00	31.40	1.220	1.236
T	0.13	—	0.005	—
U	0	—	0	—
V	31.00	31.40	1.220	1.236
W	0.4	—	0.016	—
X	1.60 REF		0.063 REF	
Y	1.33 REF		0.052 REF	
Z	1.33 REF		0.052 REF	

Case 864A-03

Figure 5. 160 QFP Package Dimensions

## 7.5 Ordering Information

Table 25. Orderable Part Numbers

Freescale Part Number	Description	Speed	Temperature
PCF5270AB100	MCF5270 RISC Microprocessor, 160 QFP	100MHz	0° to +70° C
PCF5270VM100	MCF5270 RISC Microprocessor, 196 MAPBGA	100MHz	0° to +70° C
PCF5271CAB100	MCF5271 RISC Microprocessor, 160 QFP	100MHz	-40° to +85° C
PCF5271CVM100	MCF5271 RISC Microprocessor, 196 MAPBGA	100MHz	-40° to +85° C

## 8 Preliminary Electrical Characteristics

This chapter contains electrical specification tables and reference timing diagrams for the MCF5271 microcontroller unit. This section contains detailed information on power considerations, DC/AC electrical characteristics, and AC timing specifications of MCF5271.

The electrical specifications are preliminary and are from previous designs or design simulations. These specifications may not be fully tested or guaranteed at this early stage of the product life cycle, however for production silicon these specifications will be met. Finalized specifications will be published after complete characterization and device qualifications have been completed.

### NOTE

The parameters specified in this processor document supersede any values found in the module specifications.

### 8.1 Maximum Ratings

Table 26. Absolute Maximum Ratings<sup>1, 2</sup>

Rating	Symbol	Value	Unit
Core Supply Voltage	$V_{DD}$	- 0.5 to +2.0	V
Pad Supply Voltage	$OV_{DD}$	- 0.3 to +4.0	V
Clock Synthesizer Supply Voltage	$V_{DDPLL}$	- 0.3 to +4.0	V
Digital Input Voltage <sup>3</sup>	$V_{IN}$	- 0.3 to + 4.0	V
Instantaneous Maximum Current Single pin limit (applies to all pins) <sup>3,4,5</sup>	$I_D$	25	mA
Operating Temperature Range (Packaged)	$T_A$ ( $T_L - T_H$ )	- 40 to 85	°C
Storage Temperature Range	$T_{stg}$	- 65 to 150	°C

#### NOTES:

<sup>1</sup> Functional operating conditions are given in DC Electrical Specifications. Absolute Maximum Ratings are stress ratings only, and functional operation at the maxima is not guaranteed. Continued operation at these levels may affect device reliability or cause permanent damage to the device.



- 2 This device contains circuitry protecting against damage due to high static voltage or electrical fields; however, it is advised that normal precautions be taken to avoid application of any voltages higher than maximum-rated voltages to this high-impedance circuit. Reliability of operation is enhanced if unused inputs are tied to an appropriate logic voltage level (e.g., either  $V_{SS}$  or  $OV_{DD}$ ).
- 3 Input must be current limited to the value specified. To determine the value of the required current-limiting resistor, calculate resistance values for positive and negative clamp voltages, then use the larger of the two values.
- 4 All functional non-supply pins are internally clamped to  $V_{SS}$  and  $OV_{DD}$ .
- 5 Power supply must maintain regulation within operating  $OV_{DD}$  range during instantaneous and operating maximum current conditions. If positive injection current ( $V_{in} > OV_{DD}$ ) is greater than  $I_{DD}$ , the injection current may flow out of  $OV_{DD}$  and could result in external power supply going out of regulation. Insure external  $OV_{DD}$  load will shunt current greater than maximum injection current. This will be the greatest risk when the processor is not consuming power (ex; no clock). Power supply must maintain regulation within operating  $OV_{DD}$  range during instantaneous and operating maximum current conditions.

## 8.2 Thermal Characteristics

Table 27 lists thermal resistance values

Table 27. Thermal Characteristics

Characteristic		Symbol	196 MAPBGA	160QFP	Unit
Junction to ambient, natural convection	Four layer board (2s2p)	$\theta_{JMA}$	32 <sup>1,2</sup>	40 <sup>3,4</sup>	°C/W
Junction to ambient (@200 ft/min)	Four layer board (2s2p)	$\theta_{JMA}$	29 <sup>5,6</sup>	36 <sup>5,6</sup>	°C/W
Junction to board		$\theta_{JB}$	20 <sup>5</sup>	25 <sup>6</sup>	°C/W
Junction to case		$\theta_{JC}$	10 <sup>7</sup>	10 <sup>8</sup>	°C/W
Junction to top of package		$\Psi_{jt}$	2 <sup>5,9</sup>	2 <sup>5,10</sup>	°C/W
Maximum operating junction temperature		$T_j$	104	105	°C

NOTES:

- 1  $\theta_{JMA}$  and  $\Psi_{jt}$  parameters are simulated in conformance with EIA/JESD Standard 51-2 for natural convection. Motorola recommends the use of  $\theta_{JMA}$  and power dissipation specifications in the system design to prevent device junction temperatures from exceeding the rated specification. System designers should be aware that device junction temperatures can be significantly influenced by board layout and surrounding devices. Conformance to the device junction temperature specification can be verified by physical measurement in the customer's system using the  $\Psi_{jt}$  parameter, the device power dissipation, and the method described in EIA/JESD Standard 51-2.
- 2 Per JEDEC JESD51-6 with the board horizontal.
- 3  $\theta_{JMA}$  and  $\Psi_{jt}$  parameters are simulated in conformance with EIA/JESD Standard 51-2 for natural convection. Motorola recommends the use of  $\theta_{JMA}$  and power dissipation specifications in the system design to prevent device junction temperatures from exceeding the rated specification. System designers should be aware that device junction temperatures can be significantly influenced by board layout and surrounding devices. Conformance to the device junction temperature specification can be verified by physical measurement in the customer's system using the  $\Psi_{jt}$  parameter, the device power dissipation, and the method described in EIA/JESD Standard 51-2.
- 4 Per JEDEC JESD51-6 with the board horizontal.
- 5 Thermal resistance between the die and the printed circuit board in conformance with JEDEC JESD51-8. Board temperature is measured on the top surface of the board near the package.
- 6 Thermal resistance between the die and the printed circuit board in conformance with JEDEC JESD51-8. Board temperature is measured on the top surface of the board near the package.

## Preliminary Electrical Characteristics

- <sup>7</sup> Thermal resistance between the die and the case top surface as measured by the cold plate method (MIL SPEC-883 Method 1012.1).
- <sup>8</sup> Thermal resistance between the die and the case top surface as measured by the cold plate method (MIL SPEC-883 Method 1012.1).
- <sup>9</sup> Thermal characterization parameter indicating the temperature difference between package top and the junction temperature per JEDEC JESD51-2. When Greek letters are not available, the thermal characterization parameter is written in conformance with Psi-JT.
- <sup>10</sup> Thermal characterization parameter indicating the temperature difference between package top and the junction temperature per JEDEC JESD51-2. When Greek letters are not available, the thermal characterization parameter is written in conformance with Psi-JT.

The average chip-junction temperature ( $T_J$ ) in °C can be obtained from:

$$T_J = T_A + (P_D \times \Theta_{JMA}) \quad (1)$$

Where:

$T_A$  = Ambient Temperature, °C

$\Theta_{JMA}$  = Package Thermal Resistance, Junction-to-Ambient, °C/W

$P_D = P_{INT} + P_{I/O}$

$P_{INT} = I_{DD} \times V_{DD}$ , Watts - Chip Internal Power

$P_{I/O}$  = Power Dissipation on Input and Output Pins — User Determined

For most applications  $P_{I/O} < P_{INT}$  and can be ignored. An approximate relationship between  $P_D$  and  $T_J$  (if  $P_{I/O}$  is neglected) is:

$$P_D = K \div (T_J + 273^\circ\text{C}) \quad (2)$$

Solving equations 1 and 2 for K gives:

$$K = P_D \times (T_A + 273^\circ\text{C}) + \Theta_{JMA} \times P_D^2 \quad (3)$$

where K is a constant pertaining to the particular part. K can be determined from equation (3) by measuring  $P_D$  (at equilibrium) for a known  $T_A$ . Using this value of K, the values of  $P_D$  and  $T_J$  can be obtained by solving equations (1) and (2) iteratively for any value of  $T_A$ .

## 8.3 DC Electrical Specifications

Table 28. DC Electrical Specifications<sup>1</sup>

Characteristic	Symbol	Min	Typical	Max	Unit
Core Supply Voltage	$V_{DD}$	1.35	—	1.65	V
Pad Supply Voltage	$OV_{DD}$	3	—	3.6	V
Input High Voltage	$V_{IH}$	0.7 $OV_{DD}$	—	3.65	V
Input Low Voltage	$V_{IL}$	$V_{SS} - 0.3$	—	0.35 $OV_{DD}$	V
Input Hysteresis	$V_{HYS}$	0.06 $OV_{DD}$	—	—	mV
Input Leakage Current $V_{in} = V_{DD}$ or $V_{SS}$ , Input-only pins	$I_{in}$	-1.0	—	1.0	$\mu\text{A}$

Table 28. DC Electrical Specifications<sup>1</sup> (continued)

Characteristic	Symbol	Min	Typical	Max	Unit
High Impedance (Off-State) Leakage Current $V_{in} = V_{DD}$ or $V_{SS}$ , All input/output and output pins	$I_{OZ}$	-1.0	—	1.0	$\mu A$
Output High Voltage (All input/output and all output pins) $I_{OH} = -5.0$ mA	$V_{OH}$	$0V_{DD} - 0.5$	—	—	V
Output Low Voltage (All input/output and all output pins) $I_{OL} = 5.0$ mA	$V_{OL}$	—	—	0.5	V
Weak Internal Pull Up Device Current, tested at $V_{IL}$ Max. <sup>2</sup>	$I_{APU}$	-10	—	-130	$\mu A$
Input Capacitance <sup>3</sup> All input-only pins All input/output (three-state) pins	$C_{in}$	— —	—	7 7	pF
Load Capacitance <sup>4</sup> Low drive strength High drive strength	$C_L$		—	25 50	pF
Core Operating Supply Current <sup>5</sup> Master Mode	$I_{DD}$	—	135	150	mA
Pad Operating Supply Current Master Mode Low Power Modes	$O_{IDD}$	— —	100 TBD	— —	mA $\mu A$
DC Injection Current <sup>3, 6, 7, 8</sup> $V_{NEGCLAMP} = V_{SS} - 0.3$ V, $V_{POSCLAMP} = V_{DD} + 0.3$ Single Pin Limit Total processor Limit, Includes sum of all stressed pins	$I_{IC}$				mA
		-1.0 -10		1.0 10	

## NOTES:

- <sup>1</sup> Refer to Table 29 for additional PLL specifications.
- <sup>2</sup> Refer to the MCF5271 signals section for pins having weak internal pull-up devices.
- <sup>3</sup> This parameter is characterized before qualification rather than 100% tested.
- <sup>4</sup> pF load ratings are based on DC loading and are provided as an indication of driver strength. High speed interfaces require transmission line analysis to determine proper drive strength and termination. See [High Speed Signal Propagation: Advanced Black Magic](#) by Howard W. Johnson for design guidelines.
- <sup>5</sup> Current measured at maximum system clock frequency, all modules active, and default drive strength with matching load.
- <sup>6</sup> All functional non-supply pins are internally clamped to  $V_{SS}$  and their respective  $V_{DD}$ .
- <sup>7</sup> Input must be current limited to the value specified. To determine the value of the required current-limiting resistor, calculate resistance values for positive and negative clamp voltages, then use the larger of the two values.
- <sup>8</sup> Power supply must maintain regulation within operating  $V_{DD}$  range during instantaneous and operating maximum current conditions. If positive injection current ( $V_{in} > V_{DD}$ ) is greater than  $I_{DD}$ , the injection current may flow out of  $V_{DD}$  and could result in external power supply going out of regulation. Insure external  $V_{DD}$  load will shunt current greater than maximum injection current. This will be the greatest risk when the processor is not consuming power. Examples are: if no system clock is present, or if clock rate is very low which would reduce overall power consumption. Also, at power-up, system clock is not present during the power-up sequence until the PLL has attained lock.

## 8.4 Oscillator and PLLMRFM Electrical Characteristics

Table 29. HiP7 PLLMRFM Electrical Specifications<sup>1</sup>

Num	Characteristic	Symbol	Min. Value	Max. Value	Unit
1	PLL Reference Frequency Range Crystal reference External reference 1:1 mode (NOTE: $f_{\text{sys}/2} = 2 \times f_{\text{ref}_1:1}$ )	$f_{\text{ref\_crystal}}$ $f_{\text{ref\_ext}}$ $f_{\text{ref}_1:1}$	8 8 24	25 25 50	MHz
2	Core frequency CLKOUT Frequency <sup>2</sup> External reference On-Chip PLL Frequency	$f_{\text{sys}}$ $f_{\text{sys}/2}$	0 $f_{\text{ref}} / 32$	100 50 50	MHz MHz MHz
3	Loss of Reference Frequency <sup>3, 5</sup>	$f_{\text{LOR}}$	100	1000	kHz
4	Self Clocked Mode Frequency <sup>4, 5</sup>	$f_{\text{SCM}}$	10.25	15.25	MHz
5	Crystal Start-up Time <sup>5, 6</sup>	$t_{\text{cst}}$	—	10	ms
6	XTAL Load Capacitance <sup>5</sup>		5	30	pF
7	PLL Lock Time <sup>5, 7, 13</sup>	$t_{\text{pll}}$	—	750	$\mu\text{s}$
8	Power-up To Lock Time <sup>5, 6, 8</sup> With Crystal Reference (includes 5 time) Without Crystal Reference <sup>9</sup>	$t_{\text{plk}}$	— —	11 750	ms $\mu\text{s}$
9	1:1 Mode Clock Skew (between CLKOUT and EXTAL) <sup>10</sup>	$t_{\text{skew}}$	-1	1	ns
10	Duty Cycle of reference <sup>5</sup>	$t_{\text{dc}}$	40	60	%
11	Frequency un-LOCK Range	$f_{\text{UL}}$	-3.8	4.1	% $f_{\text{sys}/2}$
12	Frequency LOCK Range	$f_{\text{LCK}}$	-1.7	2.0	% $f_{\text{sys}/2}$
13	CLKOUT Period Jitter, <sup>5, 6, 8, 11, 12</sup> Measured at $f_{\text{sys}/2}$ Max Peak-to-peak Jitter (Clock edge to clock edge) Long Term Jitter (Averaged over 2 ms interval)	$C_{\text{jitter}}$	— —	5.0 .01	% $f_{\text{sys}/2}$
14	Frequency Modulation Range Limit <sup>13, 14</sup> ( $f_{\text{sys}/2}$ Max must not be exceeded)	$C_{\text{mod}}$	0.8	2.2	% $f_{\text{sys}/2}$
15	ICO Frequency. $f_{\text{ico}} = f_{\text{ref}} * 2 * (\text{MFD}+2)$ <sup>15</sup>	$f_{\text{ico}}$	48	75	MHz

NOTES:

- <sup>1</sup> All values given are initial design targets and subject to change.
- <sup>2</sup> All internal registers retain data at 0 Hz.
- <sup>3</sup> "Loss of Reference Frequency" is the reference frequency detected internally, which transitions the PLL into self clocked mode.
- <sup>4</sup> Self clocked mode frequency is the frequency that the PLL operates at when the reference frequency falls below  $f_{\text{LOR}}$  with default MFD/RFD settings.
- <sup>5</sup> This parameter is guaranteed by characterization before qualification rather than 100% tested.
- <sup>6</sup> Proper PC board layout procedures must be followed to achieve specifications.

- <sup>7</sup> This specification applies to the period required for the PLL to relock after changing the MFD frequency control bits in the synthesizer control register (SYNCR).
- <sup>8</sup> Assuming a reference is available at power up, lock time is measured from the time  $V_{DD}$  and  $V_{DDSYN}$  are valid to  $\overline{RSTOUT}$  negating. If the crystal oscillator is being used as the reference for the PLL, then the crystal start up time must be added to the PLL lock time to determine the total start-up time.
- <sup>9</sup>  $t_{pll} = (64 \cdot 4 \cdot 5 + 5 \cdot \tau) \cdot T_{ref}$ , where  $T_{ref} = 1/F_{ref\_crystal} = 1/F_{ref\_ext} = 1/F_{ref\_1:1}$ , and  $\tau = 1.57 \times 10^{-6} \cdot 2(MFD + 2)$ .
- <sup>10</sup> PLL is operating in 1:1 PLL mode.
- <sup>11</sup> Jitter is the average deviation from the programmed frequency measured over the specified interval at maximum  $f_{sys/2}$ . Measurements are made with the device powered by filtered supplies and clocked by a stable external clock signal. Noise injected into the PLL circuitry via  $V_{DDSYN}$  and  $V_{SSSYN}$  and variation in crystal oscillator frequency increase the Cjitter percentage for a given interval.
- <sup>12</sup> Values are with frequency modulation disabled. If frequency modulation is enabled, jitter is the sum of Cjitter+Cmod.
- <sup>13</sup> Modulation percentage applies over an interval of 10 $\mu$ s, or equivalently the modulation rate is 100KHz.
- <sup>14</sup> Modulation rate selected must not result in  $f_{sys/2}$  value greater than the  $f_{sys/2}$  maximum specified value. Modulation range determined by hardware design.
- <sup>15</sup>  $f_{sys/2} = f_{ico} / (2 \cdot 2^{RFD})$

## 8.5 External Interface Timing Characteristics

Table 30 lists processor bus input timings.

### NOTE

All processor bus timings are synchronous; that is, input setup/hold and output delay with respect to the rising edge of a reference clock. The reference clock is the CLKOUT output.

All other timing relationships can be derived from these values.

**Table 30. Processor Bus Input Timing Specifications**

Name	Characteristic <sup>1</sup>	Symbol	Min	Max	Unit
freq	System bus frequency	$f_{sys/2}$	50	50	MHz
B0	CLKOUT period	$t_{cyc}$		1/50	ns
Control Inputs					
B1a	Control input valid to CLKOUT high <sup>2</sup>	$t_{CVCH}$	9	—	ns
B1b	$\overline{BKPT}$ valid to CLKOUT high <sup>3</sup>	$t_{BKVCH}$	9	—	ns
B2a	CLKOUT high to control inputs invalid <sup>2</sup>	$t_{CHCII}$	0	—	ns
B2b	CLKOUT high to asynchronous control input $\overline{BKPT}$ invalid <sup>3</sup>	$t_{BKNCH}$	0	—	ns
Data Inputs					
B4	Data input (D[31:0]) valid to CLKOUT high	$t_{DIVCH}$	4	—	ns
B5	CLKOUT high to data input (D[31:0]) invalid	$t_{CHDII}$	0	—	ns

NOTES:

- <sup>1</sup> Timing specifications are tested using full drive strength pad configurations in a 50ohm transmission line environment..
- <sup>2</sup>  $\overline{TEA}$  and  $\overline{TA}$  pins are being referred to as control inputs.
- <sup>3</sup> Refer to figure A-19.

## Preliminary Electrical Characteristics

Timings listed in Table 30 are shown in Figure 6 & Figure A-3.

\* The timings are also valid for inputs sampled on the negative clock edge.

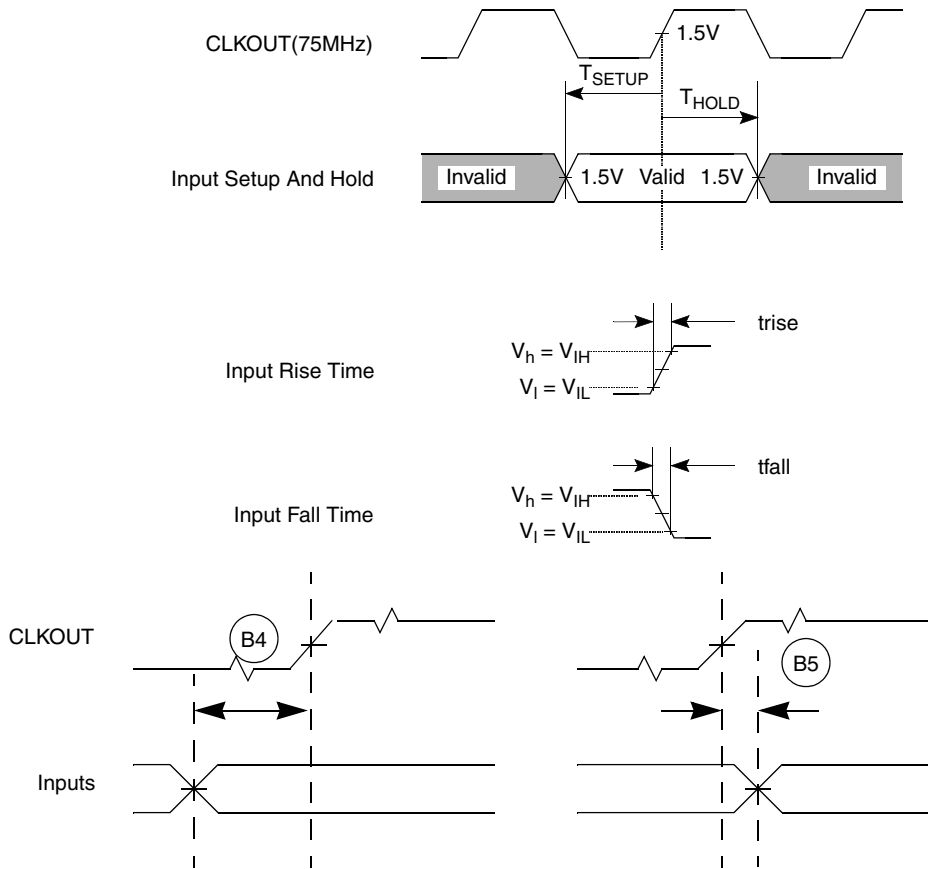

Figure 6. General Input Timing Requirements

## 8.6 Processor Bus Output Timing Specifications

Table 31 lists processor bus output timings.

Table 31. External Bus Output Timing Specifications

Name	Characteristic	Symbol	Min	Max	Unit
Control Outputs					
B6a	CLKOUT high to chip selects valid <sup>1</sup>	$t_{CHCV}$	—	$0.5t_{CYC} + 5$	ns
B6b	CLKOUT high to byte enables ( $\overline{BS}[3:0]$ ) valid <sup>2</sup>	$t_{CHBV}$	—	$0.5t_{CYC} + 5$	ns
B6c	CLKOUT high to output enable ( $\overline{OE}$ ) valid <sup>3</sup>	$t_{CHOV}$	—	$0.5t_{CYC} + 5$	ns
B7	CLKOUT high to control output ( $\overline{BS}[3:0]$ , $\overline{OE}$ ) invalid	$t_{CHCOI}$	$0.5t_{CYC} + 1.5$	—	ns
B7a	CLKOUT high to chip selects invalid	$t_{CHCI}$	$0.5t_{CYC} + 1.5$	—	ns

Table 31. External Bus Output Timing Specifications (continued)

Name	Characteristic	Symbol	Min	Max	Unit
Address and Attribute Outputs					
B8	CLKOUT high to address (A[23:0]) and control ( $\overline{TS}$ , $\overline{TSIZ}[1:0]$ , $\overline{TIP}$ , R/ $\overline{W}$ ) valid	$t_{CHAV}$	—	9	ns
B9	CLKOUT high to address (A[23:0]) and control ( $\overline{TS}$ , $\overline{TSIZ}[1:0]$ , $\overline{TIP}$ , R/ $\overline{W}$ ) invalid	$t_{CHAI}$	1.5	—	ns
Data Outputs					
B11	CLKOUT high to data output (D[31:0]) valid	$t_{CHDOV}$	—	9	ns
B12	CLKOUT high to data output (D[31:0]) invalid	$t_{CHDOI}$	1.5	—	ns
B13	CLKOUT high to data output (D[31:0]) high impedance	$t_{CHDOZ}$	—	9	ns

## NOTES:

- <sup>1</sup>  $\overline{CS}$  transitions after the falling edge of CLKOUT.
- <sup>2</sup>  $\overline{BS}$  transitions after the falling edge of CLKOUT.
- <sup>3</sup>  $\overline{OE}$  transitions after the falling edge of CLKOUT.

Read/write bus timings listed in Table 31 are shown in Figure 7, Figure 8, and Figure 9.

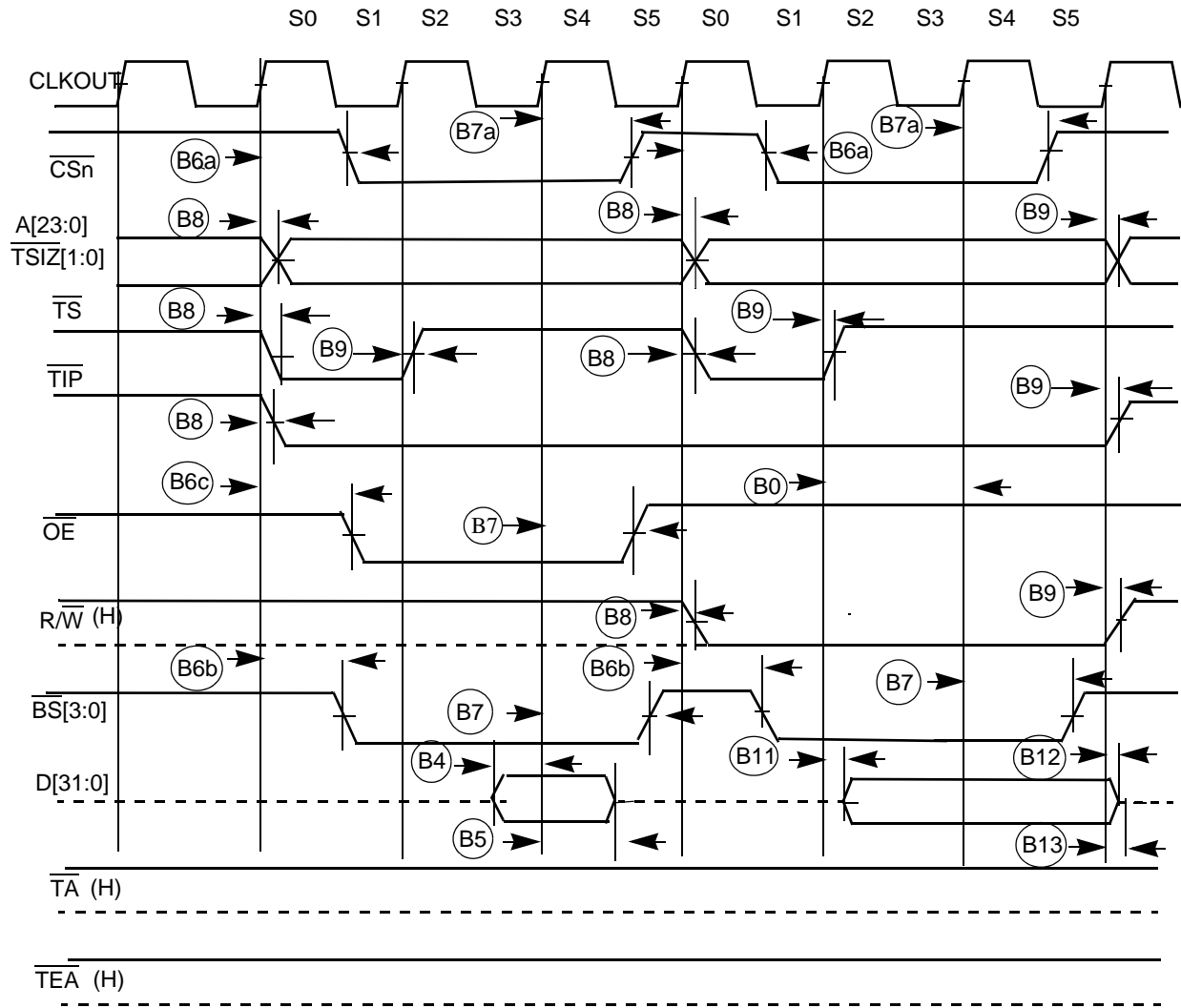

Figure 7. Read/Write (Internally Terminated) SRAM Bus Timing



Figure 8 shows a bus cycle terminated by  $\overline{TA}$  showing timings listed in Table 31.

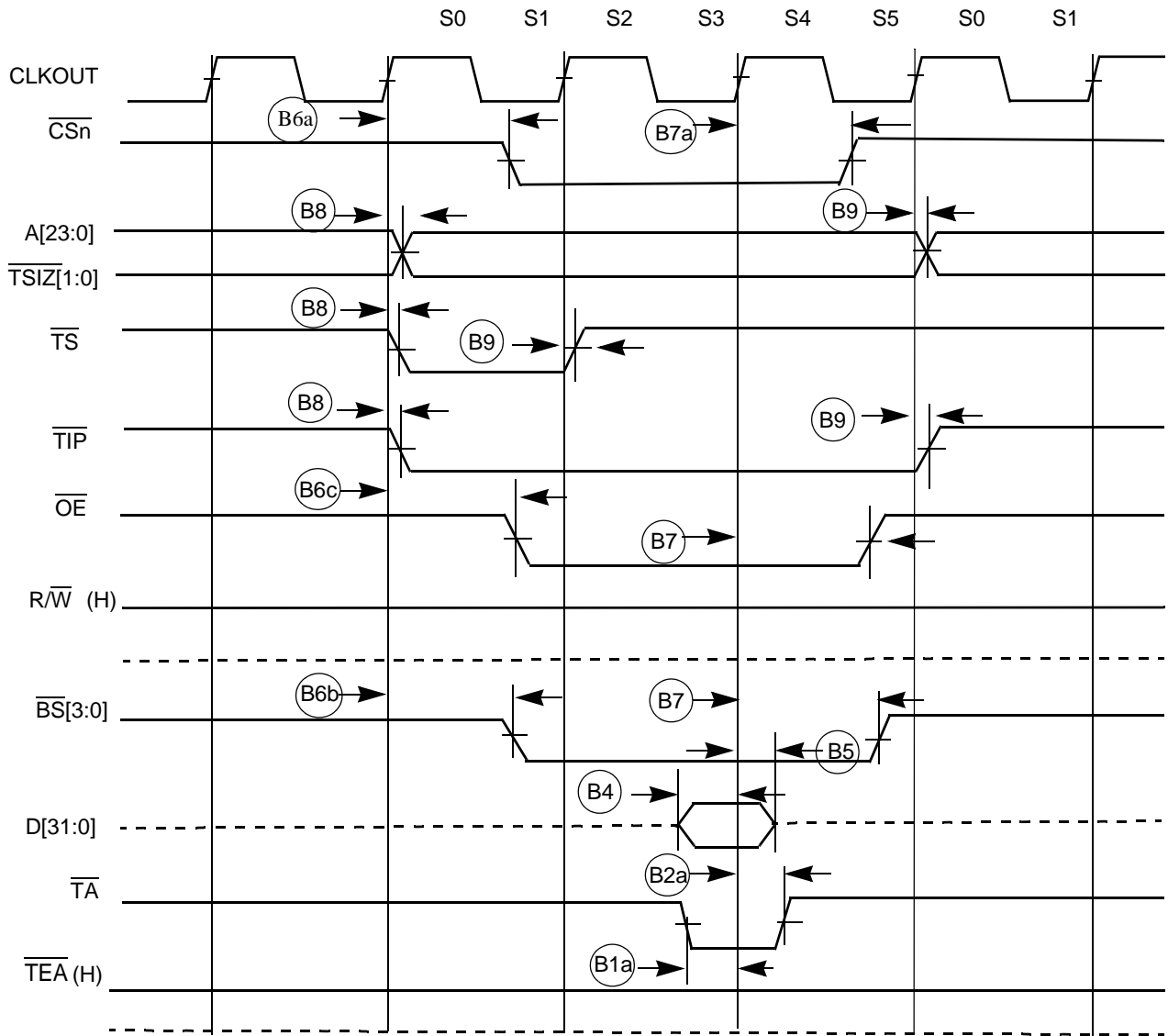

Figure 8. SRAM Read Bus Cycle Terminated by  $\overline{TA}$

Figure 9 shows an SRAM bus cycle terminated by  $\overline{\text{TEA}}$  showing timings listed in Table 31.

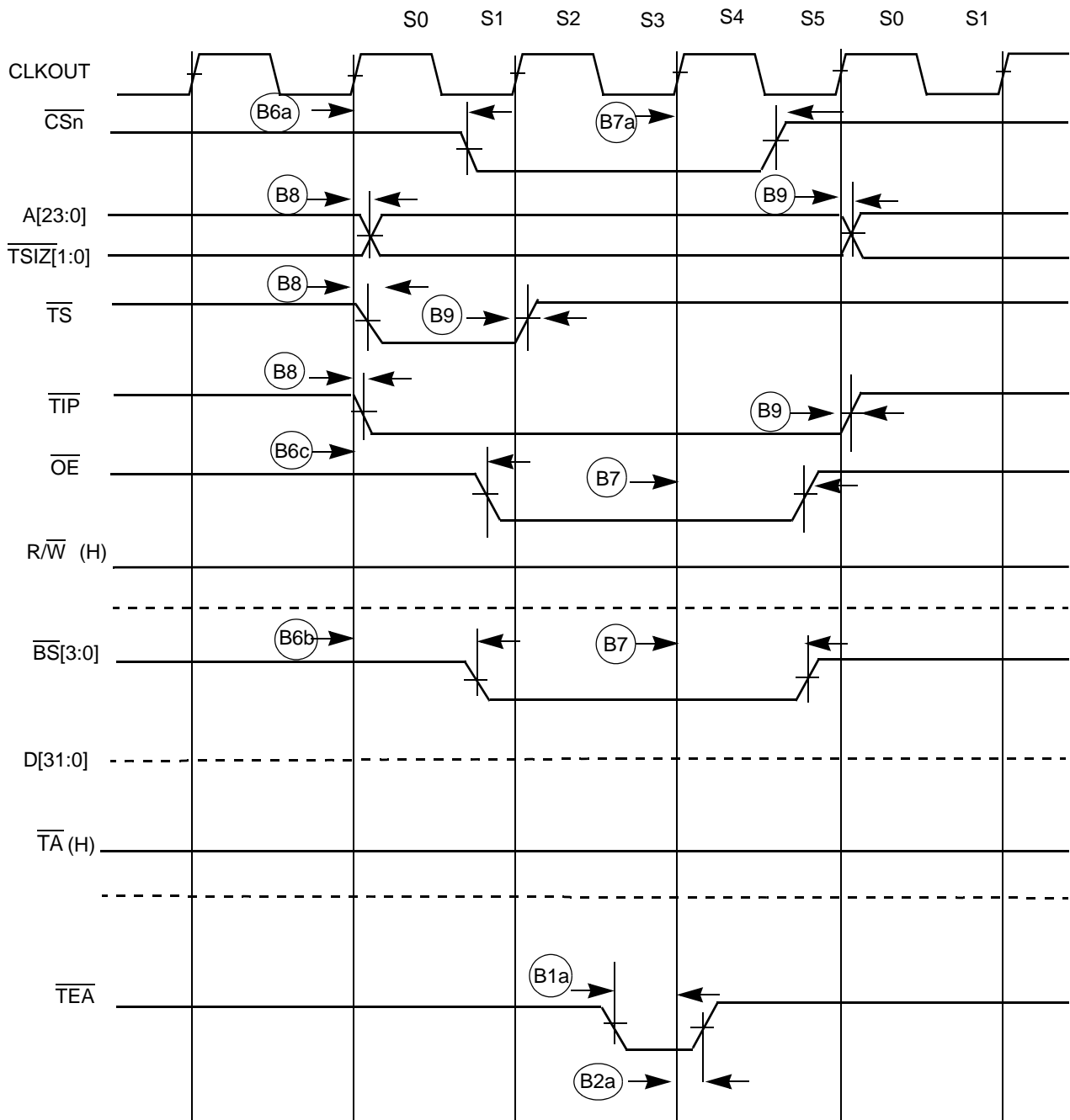

Figure 9. SRAM Read Bus Cycle Terminated by  $\overline{\text{TEA}}$

Figure 10 shows an SDRAM read cycle.

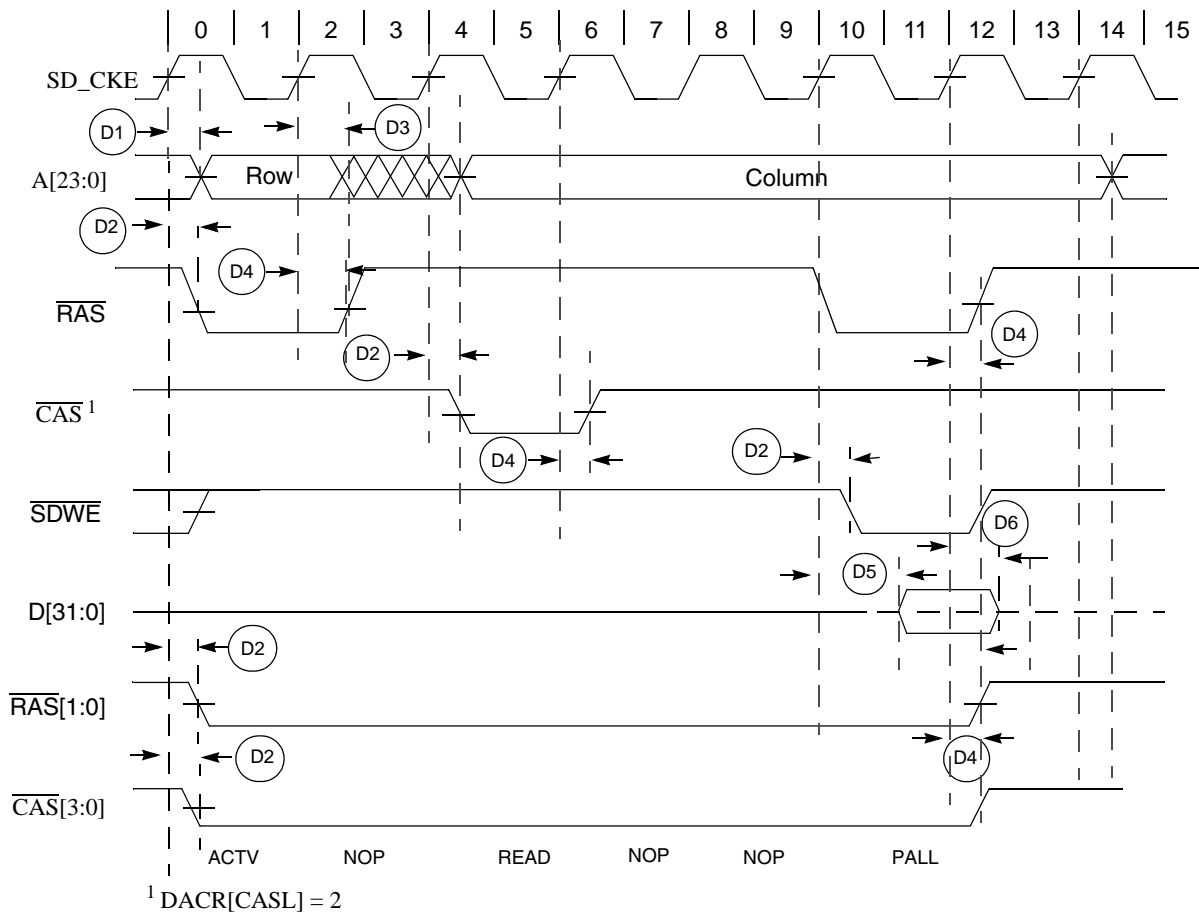

Figure 10. SDRAM Read Cycle

Table 32. SDRAM Timing

NUM	Characteristic	Symbol	Min	Max	Unit
D1	CLKOUT high to SDRAM address valid	$t_{CHDAV}$	—	9	ns
D2	CLKOUT high to SDRAM control valid	$t_{CHDCV}$	—	9	ns
D3	CLKOUT high to SDRAM address invalid	$t_{CHDAI}$	1.5	—	ns
D4	CLKOUT high to SDRAM control invalid	$t_{CHDCI}$	1.5	—	ns
D5	SDRAM data valid to CLKOUT high	$t_{DDVCH}$	4	—	ns
D6	CLKOUT high to SDRAM data invalid	$t_{CHDDI}$	1.5	—	ns
D7 <sup>1</sup>	CLKOUT high to SDRAM data valid	$t_{CHDDVW}$	—	9	ns
D8 <sup>2</sup>	CLKOUT high to SDRAM data invalid	$t_{CHDDIW}$	1.5	—	ns

NOTES:

<sup>1</sup> D7 and D8 are for write cycles only.

Figure 11 shows an SDRAM write cycle.

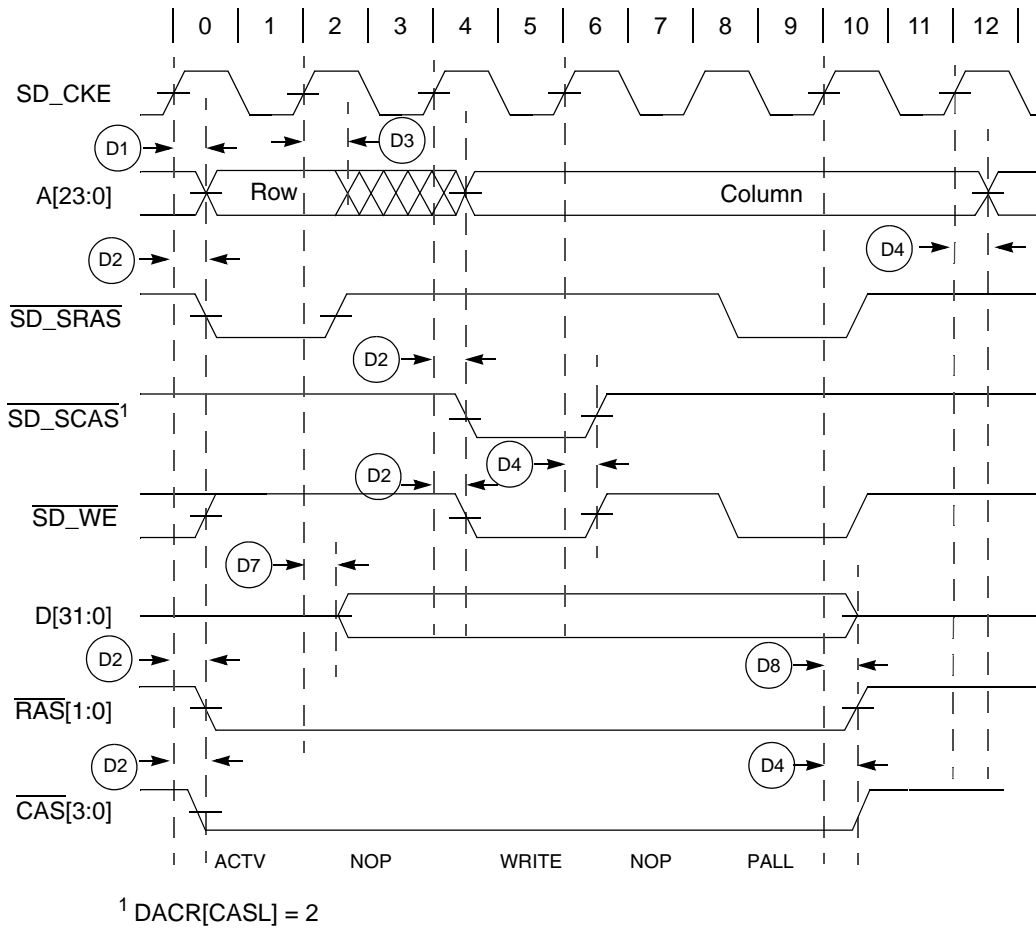

Figure 11. SDRAM Write Cycle

## 8.7 General Purpose I/O Timing

Table 33. GPIO Timing<sup>1</sup>

NUM	Characteristic	Symbol	Min	Max	Unit
G1 G2	CLKOUT High to GPIO Output Valid	$t_{CHPOV}$	—	10	ns
	CLKOUT High to GPIO Output Invalid	$t_{CHPOI}$	1.5	—	ns
G3 G4	GPIO Input Valid to CLKOUT High	$t_{PVCH}$	9	—	ns
	CLKOUT High to GPIO Input Invalid	$t_{CHPI}$	1.5	—	ns

NOTES:

<sup>1</sup> GPIO pins include: INT, UART, and Timer pins.

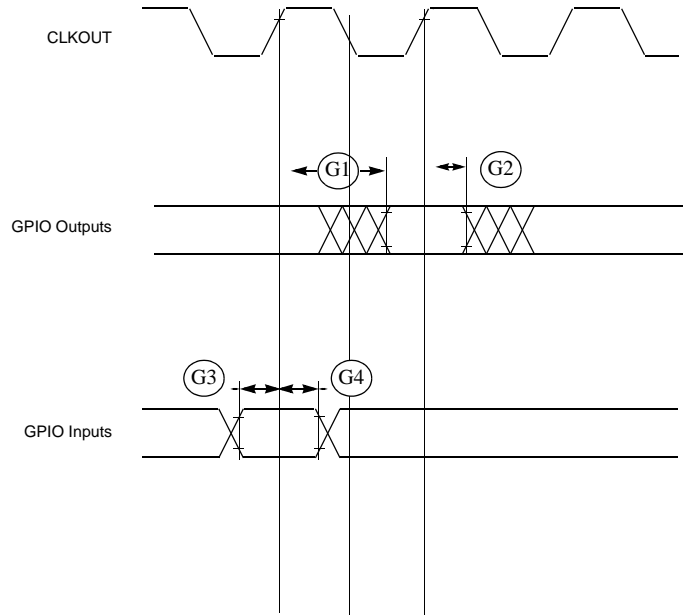

Figure 12. GPIO Timing

## 8.8 Reset and Configuration Override Timing

Table 34. Reset and Configuration Override Timing

( $V_{DD} = 2.7$  to  $3.6$  V,  $V_{SS} = 0$  V,  $T_A = T_L$  to  $T_H$ )<sup>1</sup>

NUM	Characteristic	Symbol	Min	Max	Unit
R1	$\overline{\text{RESET}}$ Input valid to CLKOUT High	$t_{RVCH}$	9	—	ns
R2	CLKOUT High to $\overline{\text{RESET}}$ Input invalid	$t_{CHRI}$	1.5	—	ns
R3	$\overline{\text{RESET}}$ Input valid Time <sup>2</sup>	$t_{RIVT}$	5	—	$t_{CYC}$
R4	CLKOUT High to $\overline{\text{RSTOUT}}$ Valid	$t_{CHROV}$	—	10	ns
R5	$\overline{\text{RSTOUT}}$ valid to Config. Overrides valid	$t_{ROVCV}$	0	—	ns
R6	Configuration Override Setup Time to $\overline{\text{RSTOUT}}$ invalid	$t_{COS}$	20	—	$t_{CYC}$
R7	Configuration Override Hold Time after $\overline{\text{RSTOUT}}$ invalid	$t_{COH}$	0	—	ns
R8	$\overline{\text{RSTOUT}}$ invalid to Configuration Override High Impedance	$t_{ROICZ}$	—	1	$t_{CYC}$

NOTES:

<sup>1</sup> All AC timing is shown with respect to 50%  $V_{DD}$  levels unless otherwise noted.

<sup>2</sup> During low power STOP, the synchronizers for the  $\overline{\text{RESET}}$  input are bypassed and  $\overline{\text{RESET}}$  is asserted asynchronously to the system. Thus,  $\overline{\text{RESET}}$  must be held a minimum of 100 ns.

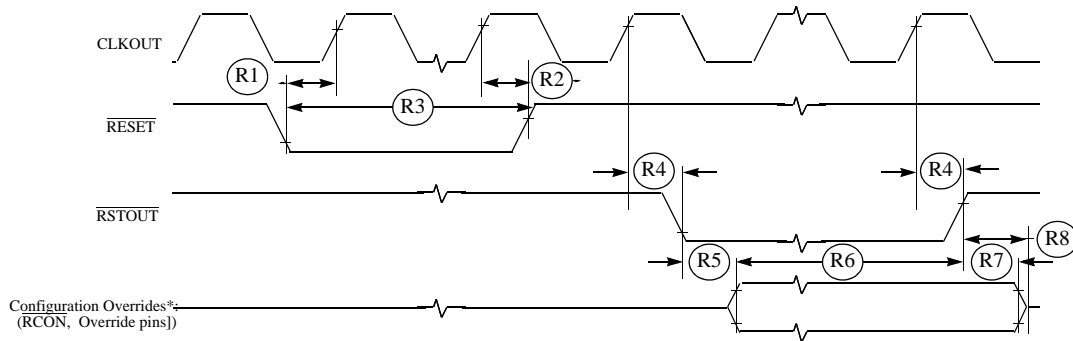

Figure 13.  $\overline{\text{RESET}}$  and Configuration Override Timing

\* Refer to the Coldfire Integration Module (CIM) section for more information.

## 8.9 I<sup>2</sup>C Input/Output Timing Specifications

Table 35 lists specifications for the I<sup>2</sup>C input timing parameters shown in Figure 14.

Table 35. I<sup>2</sup>C Input Timing Specifications between I2C\_SCL and I2C\_SDA

Num	Characteristic	Min	Max	Units
I1	Start condition hold time	2	—	t <sub>cyc</sub>
I2	Clock low period	8	—	t <sub>cyc</sub>
I3	I2C_SCL/I2C_SDA rise time (V <sub>IL</sub> = 0.5 V to V <sub>IH</sub> = 2.4 V)	—	1	ms
I4	Data hold time	0	—	ns
I5	I2C_SCL/I2C_SDA fall time (V <sub>IH</sub> = 2.4 V to V <sub>IL</sub> = 0.5 V)	—	1	ms
I6	Clock high time	4	—	t <sub>cyc</sub>
I7	Data setup time	0	—	ns
I8	Start condition setup time (for repeated start condition only)	2	—	t <sub>cyc</sub>
I9	Stop condition setup time	2	—	t <sub>cyc</sub>

Table 36 lists specifications for the I<sup>2</sup>C output timing parameters shown in Figure 14.

Table 36. I<sup>2</sup>C Output Timing Specifications between I2C\_SCL and I2C\_SDA

Num	Characteristic	Min	Max	Units
I1 <sup>1</sup>	Start condition hold time	6	—	t <sub>cyc</sub>
I2 <sup>1</sup>	Clock low period	10	—	t <sub>cyc</sub>
I3 <sup>2</sup>	I2C_SCL/I2C_SDA rise time (V <sub>IL</sub> = 0.5 V to V <sub>IH</sub> = 2.4 V)	—	—	μs
I4 <sup>1</sup>	Data hold time	7	—	t <sub>cyc</sub>
I5 <sup>3</sup>	I2C_SCL/I2C_SDA fall time (V <sub>IH</sub> = 2.4 V to V <sub>IL</sub> = 0.5 V)	—	3	ns
I6 <sup>1</sup>	Clock high time	10	—	t <sub>cyc</sub>

**Table 36. I<sup>2</sup>C Output Timing Specifications between I2C\_SCL and I2C\_SDA (continued)**

Num	Characteristic	Min	Max	Units
17 <sup>1</sup>	Data setup time	2	—	t <sub>cyc</sub>
18 <sup>1</sup>	Start condition setup time (for repeated start condition only)	20	—	t <sub>cyc</sub>
19 <sup>1</sup>	Stop condition setup time	10	—	t <sub>cyc</sub>

**NOTES:**

- <sup>1</sup> Note: Output numbers depend on the value programmed into the IFDR; an IFDR programmed with the maximum frequency (IFDR = 0x20) results in minimum output timings as shown in Table 36. The I<sup>2</sup>C interface is designed to scale the actual data transition time to move it to the middle of the I2C\_SCL low period. The actual position is affected by the prescale and division values programmed into the IFDR; however, the numbers given in Table 36 are minimum values.
- <sup>2</sup> Because I2C\_SCL and I2C\_SDA are open-collector-type outputs, which the processor can only actively drive low, the time I2C\_SCL or I2C\_SDA take to reach a high level depends on external signal capacitance and pull-up resistor values.
- <sup>3</sup> Specified at a nominal 50-pF load.

Figure 14 shows timing for the values in Table 35 and Table 36.

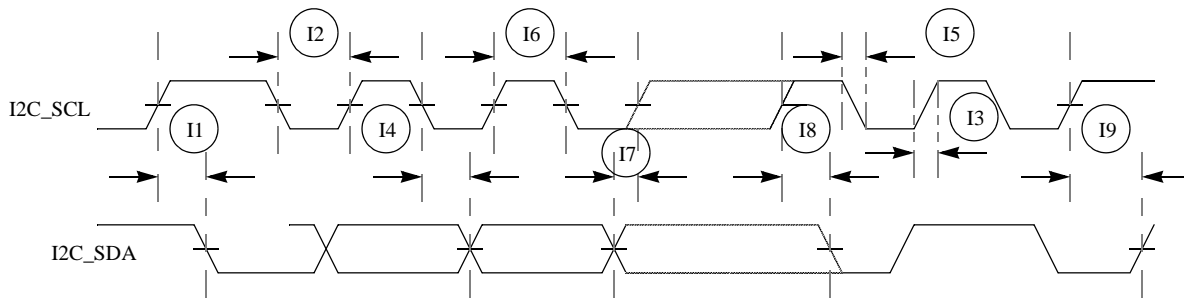
**Figure 14. I<sup>2</sup>C Input/Output Timings**

## 8.10 Fast Ethernet AC Timing Specifications

MII signals use TTL signal levels compatible with devices operating at either 5.0 V or 3.3 V.

### 8.10.1 MII Receive Signal Timing (ERXD[3:0], ERXDV, ERXER, and ERXCLK)

The receiver functions correctly up to a ERXCLK maximum frequency of 25 MHz +1%. There is no minimum frequency requirement. In addition, the processor clock frequency must exceed twice the ERXCLK frequency.

Table 37 lists MII receive channel timings.

**Table 37. MII Receive Signal Timing**

Num	Characteristic	Min	Max	Unit
M1	ERXD[3:0], ERXDV, ERXER to ERXCLK setup	5	—	ns
M2	ERXCLK to ERXD[3:0], ERXDV, ERXER hold	5	—	ns
M3	ERXCLK pulse width high	35%	65%	ERXCLK period
M4	ERXCLK pulse width low	35%	65%	ERXCLK period

Figure 15 shows MII receive signal timings listed in Table 37.

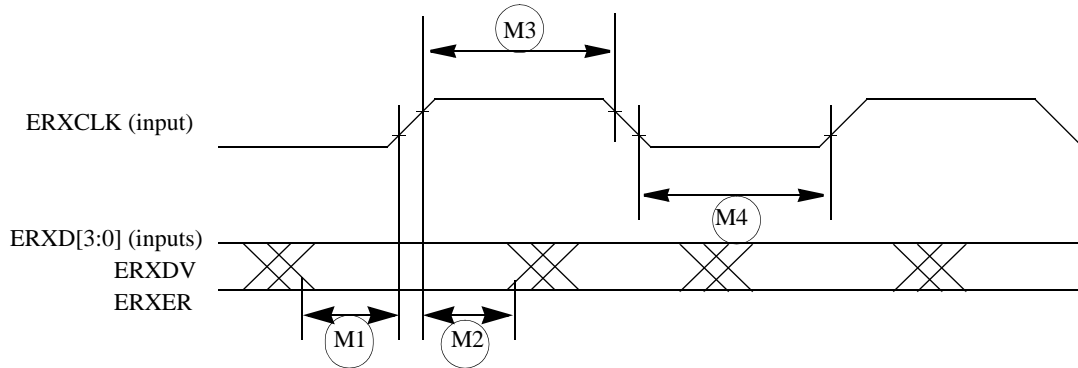

**Figure 15. MII Receive Signal Timing Diagram**

### 8.10.2 MII Transmit Signal Timing (ETXD[3:0], ETXEN, ETXER, ETXCLK)

Table 38 lists MII transmit channel timings.

The transmitter functions correctly up to a ETXCLK maximum frequency of 25 MHz +1%. There is no minimum frequency requirement. In addition, the processor clock frequency must exceed twice the ETXCLK frequency.

The transmit outputs (ETXD[3:0], ETXEN, ETXER) can be programmed to transition from either the rising or falling edge of ETXCLK, and the timing is the same in either case. This options allows the use of non-compliant MII PHYs.

Refer to the Ethernet chapter for details of this option and how to enable it.

**Table 38. MII Transmit Signal Timing**

Num	Characteristic	Min	Max	Unit
M5	ETXCLK to ETXD[3:0], ETXEN, ETXER invalid	5	—	ns
M6	ETXCLK to ETXD[3:0], ETXEN, ETXER valid	—	25	ns
M7	ETXCLK pulse width high	35%	65%	ETXCLK period
M8	ETXCLK pulse width low	35%	65%	ETXCLK period



Figure 16 shows MII transmit signal timings listed in Table 38.

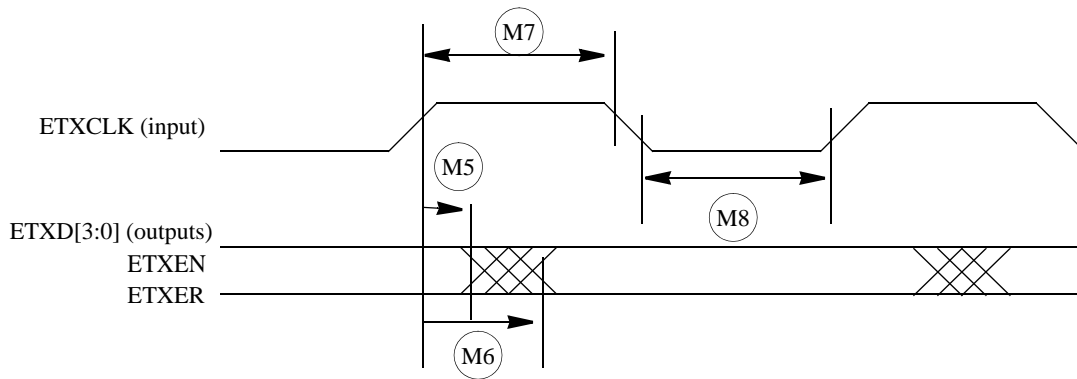

Figure 16. MII Transmit Signal Timing Diagram

### 8.10.3 MII Async Inputs Signal Timing (ECRS and ECOL)

Table 39 lists MII asynchronous inputs signal timing.

Table 39. MII Async Inputs Signal Timing

Num	Characteristic	Min	Max	Unit
M9	ECRS, ECOL minimum pulse width	1.5	—	ETXCLK period

Figure 17 shows MII asynchronous input timings listed in Table 39.

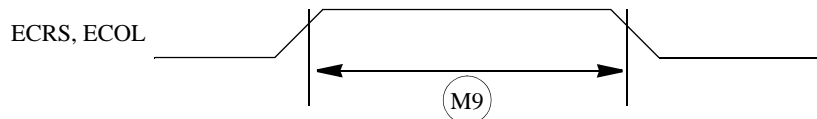

Figure 17. MII Async Inputs Timing Diagram

### 8.10.4 MII Serial Management Channel Timing (EMDIO and EMDC)

Table 40 lists MII serial management channel timings. The FEC functions correctly with a maximum MDC frequency of 2.5 MHz.

Table 40. MII Serial Management Channel Timing

Num	Characteristic	Min	Max	Unit
M10	EMDC falling edge to EMDIO output invalid (minimum propagation delay)	0	—	ns
M11	EMDC falling edge to EMDIO output valid (max prop delay)	—	25	ns
M12	EMDIO (input) to EMDC rising edge setup	10	—	ns
M13	EMDIO (input) to EMDC rising edge hold	0	—	ns
M14	EMDC pulse width high	40%	60%	MDC period
M15	EMDC pulse width low	40%	60%	MDC period

Figure 18 shows MII serial management channel timings listed in Table 40.

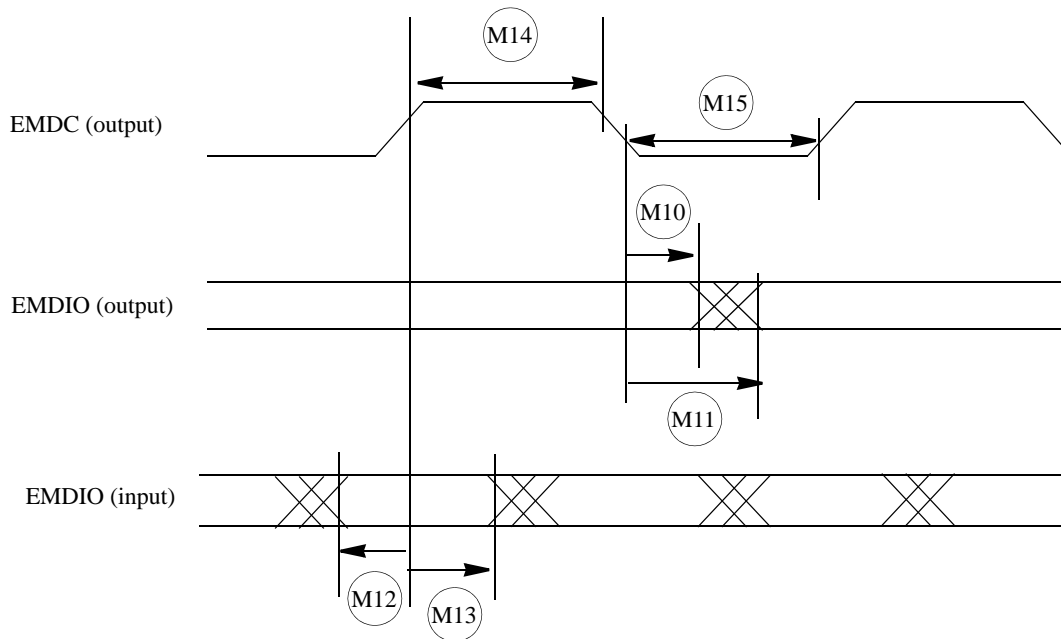

Figure 18. MII Serial Management Channel Timing Diagram

## 8.11 32-Bit Timer Module AC Timing Specifications

Table 41 lists timer module AC timings.

Table 41. Timer Module AC Timing Specifications

Name	Characteristic	0–66 MHz		Unit
		Min	Max	
T1	DT0IN / DT1IN / DT2IN / DT3IN cycle time	3	—	$t_{CYC}$
T2	DT0IN / DT1IN / DT2IN / DT3IN pulse width	1	—	$t_{CYC}$

## 8.12 QSPI Electrical Specifications

Table 42 lists QSPI timings.

Table 42. QSPI Modules AC Timing Specifications

Name	Characteristic	Min	Max	Unit
QS1	QSPI_CS[1:0] to QSPI_CLK	1	510	tcyc
QS2	QSPI_CLK high to QSPI_DOUT valid.	—	10	ns
QS3	QSPI_CLK high to QSPI_DOUT invalid. (Output hold)	2	—	ns
QS4	QSPI_DIN to QSPI_CLK (Input setup)	9	—	ns
QS5	QSPI_DIN to QSPI_CLK (Input hold)	9	—	ns

The values in Table 42 correspond to Figure 19.

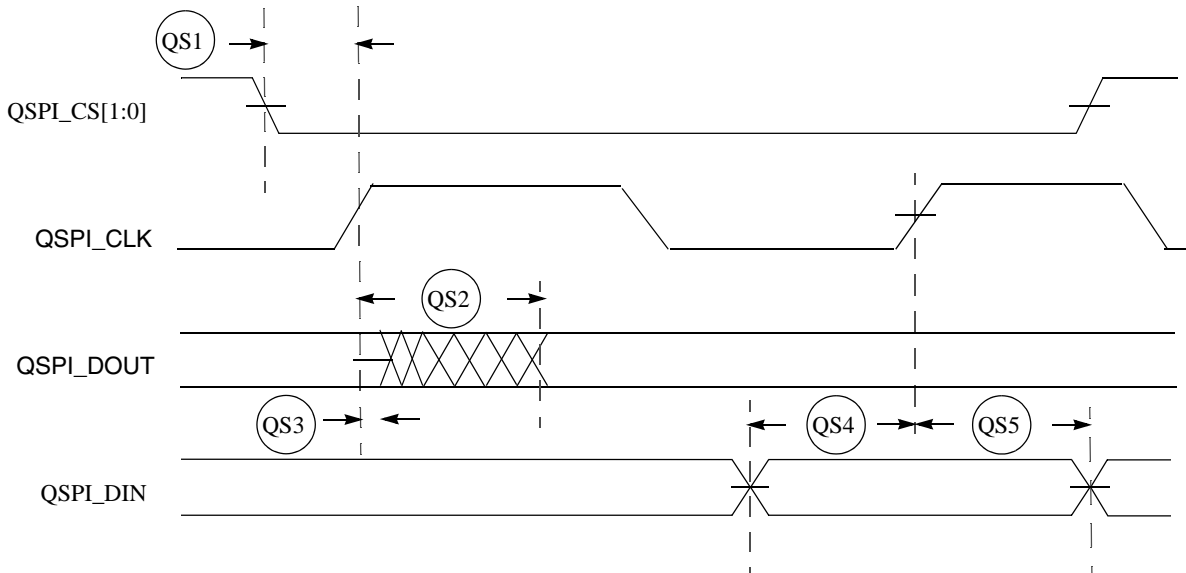

Figure 19. QSPI Timing

## 8.13 JTAG and Boundary Scan Timing

Table 43. JTAG and Boundary Scan Timing

Num	Characteristics <sup>1</sup>	Symbol	Min	Max	Unit
J1	TCLK Frequency of Operation	$f_{JCYC}$	DC	1/4	$f_{sys/2}$
J2	TCLK Cycle Period	$t_{JCYC}$	4	-	$t_{CYC}$
J3	TCLK Clock Pulse Width	$t_{JCW}$	26	-	ns
J4	TCLK Rise and Fall Times	$t_{JCRF}$	0	3	ns
J5	Boundary Scan Input Data Setup Time to TCLK Rise	$t_{BSDST}$	4	-	ns
J6	Boundary Scan Input Data Hold Time after TCLK Rise	$t_{BSDHT}$	26	-	ns
J7	TCLK Low to Boundary Scan Output Data Valid	$t_{BSDV}$	0	33	ns
J8	TCLK Low to Boundary Scan Output High Z	$t_{BSDZ}$	0	33	ns
J9	TMS, TDI Input Data Setup Time to TCLK Rise	$t_{TAPBST}$	4	-	ns
J10	TMS, TDI Input Data Hold Time after TCLK Rise	$t_{TAPBHT}$	10	-	ns
J11	TCLK Low to TDO Data Valid	$t_{TDODV}$	0	26	ns
J12	TCLK Low to TDO High Z	$t_{TDODZ}$	0	8	ns
J13	$\overline{TRST}$ Assert Time	$t_{TRSTAT}$	100	-	ns
J14	$\overline{TRST}$ Setup Time (Negation) to TCLK High	$t_{TRSTST}$	10	-	ns

NOTES:

<sup>1</sup> JTAG\_EN is expected to be a static signal. Hence, specific timing is not associated with it.

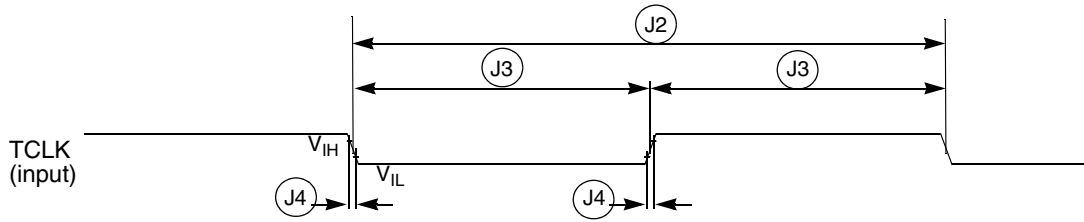

Figure 20. Test Clock Input Timing

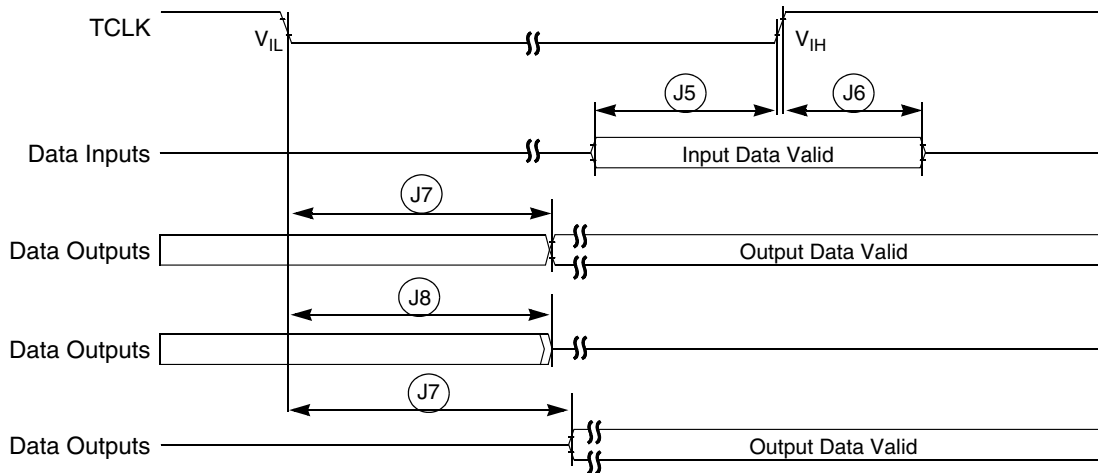

Figure 21. Boundary Scan (JTAG) Timing

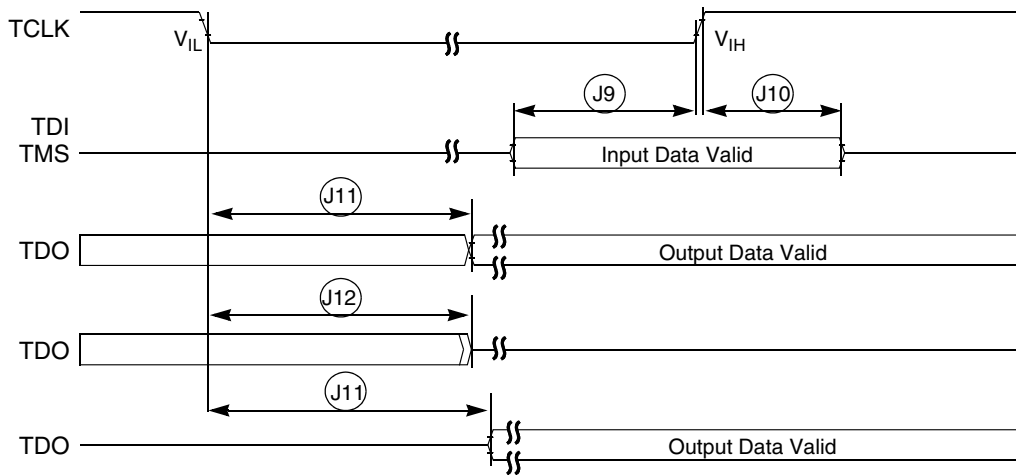

Figure 22. Test Access Port Timing

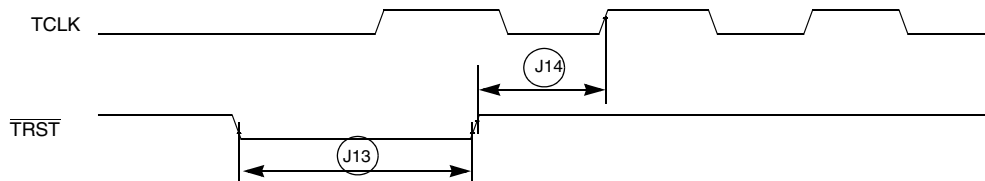

Figure 23. TRST Timing

## 8.14 Debug AC Timing Specifications

Table 44 lists specifications for the debug AC timing parameters shown in Figure 25.

Table 44. Debug AC Timing Specification

Num	Characteristic	150 MHz		Units
		Min	Max	
DE0	PSTCLK cycle time		0.5	$t_{cyc}$
DE1	PST valid to PSTCLK high	4		ns
DE2	PSTCLK high to PST invalid	1.5		ns
DE3	DSCLK cycle time	5		$t_{cyc}$
DE4	DSI valid to DSCLK high	1		$t_{cyc}$

**Table 44. Debug AC Timing Specification (continued)**

Num	Characteristic	150 MHz		Units
		Min	Max	
DE5 <sup>1</sup>	DSCLK high to DSO invalid	4		t <sub>cyc</sub>
DE6	$\overline{\text{BKPT}}$ input data setup time to CLKOUT Rise	4		ns
DE7	CLKOUT high to $\overline{\text{BKPT}}$ high Z	0	10	ns

NOTES:

<sup>1</sup> DSCLK and DSI are synchronized internally. D4 is measured from the synchronized DSCLK input relative to the rising edge of CLKOUT.

Figure 24 shows real-time trace timing for the values in Table 44.

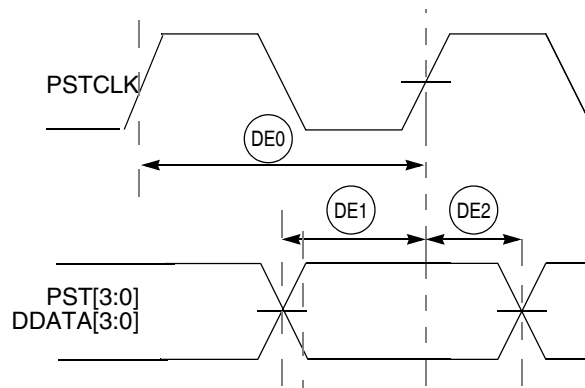

**Figure 24. Real-Time Trace AC Timing**

Figure 25 shows BDM serial port AC timing for the values in Table 44.

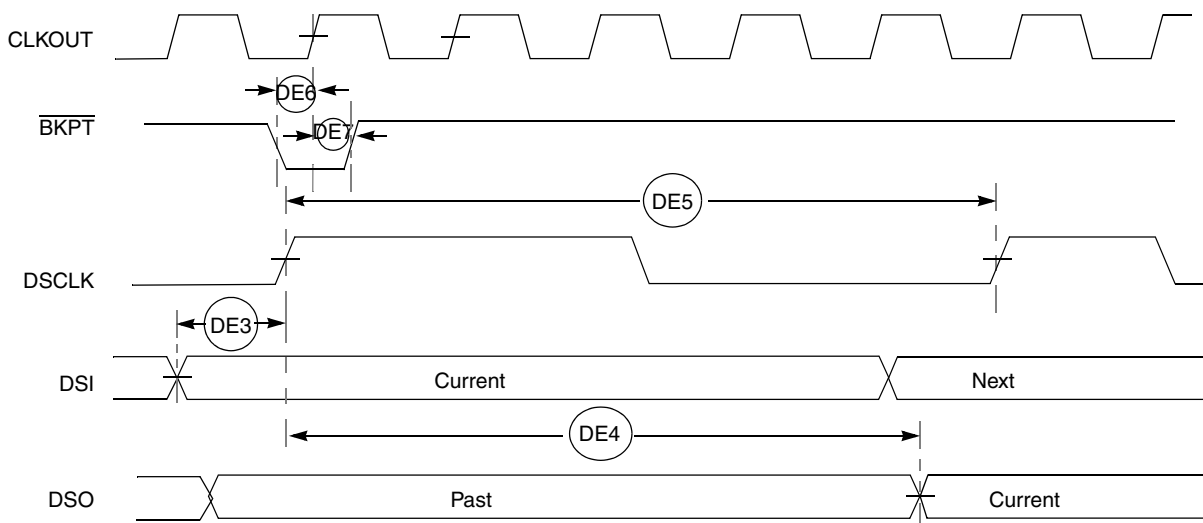

**Figure 25. BDM Serial Port AC Timing**

## 9 Documentation

Table 45 lists the documents that provide a complete description of the MCF5271 and their development support tools. Documentation is available from a local Freescale distributor, a Freescale semiconductor sales office, the Freescale Literature Distribution Center, or through the Freescale world-wide web address at <http://www.freescale.com>.

**Table 45. MCF5271 Documentation**

Freescle Document Number	Title	Revision	Status
MCF5271EC	MCF5271 RISC Microprocessor Hardware Specifications	Rev. 1.2	This document
MCF5271RM	MCF5271 Reference Manual	1.1	Available
MCF5271PB	MCF5271 Product Brief	0	Available
MCF5271FS	MCF5271 Fact Sheet	—	In Process
CFPRODFACT/D	The ColdFire Family of 32-Bit Microprocessors Family Overview and Technology Roadmap	0	Available under NDA
MCF5xxxWP	MCF5xxxWP WHITE PAPER: Motorola ColdFire VL RISC Processors	0	Available under NDA
MAPBGAPP	MAPBGA 4-Layer Example	0	Available
CFPRM/D	ColdFire Family Programmer's Reference Manual	2	Available

### 9.1 Document Revision History

Table 46 provides a revision history for this document.

**Table 46. Document Revision History**

Rev. No.	Substantive Change(s)
0	Initial release
1	- Fixed several clock values. - Updated Signal List table
1.1	- Removed duplicate information in the module description sections. The information is all in the Signals Description Table.
1.2	- Removed detailed signal description section. This information can be found in the MCF5235RM Chapter 2. - Removed detailed feature list. This information can be found in the MCF5235RM Chapter 1. - Changed instances of Motorola to Freescale - Added values for 'Maximum operating junction temperature' in Table 27. - Added typical values for 'Core operating supply current (master mode)' in Table 28. - Added typical values for 'Pad operating supply current (master mode)' in Table 28. - Removed unnecessary PLL specifications, #6-9, in Table 29.

## **HOW TO REACH US:**

### **USA/Europe/Locations not listed:**

Freescale Semiconductor Literature Distribution  
P.O. Box 5405, Denver, Colorado 80217  
1-800-521-6274 or 480-768-2130

### **Japan:**

Freescale Semiconductor Japan Ltd.  
Technical Information Center  
3-20-1, Minami-Azabu, Minato-ku  
Tokyo 106-8573, Japan  
81-3-3440-3569

### **Asia/Pacific:**

Freescale Semiconductor H.K. Ltd.  
2 Dai King Street  
Tai Po Industrial Estate  
Tai Po, N.T. Hong Kong  
852-26668334

### *Learn More:*

For more information about Freescale Semiconductor products, please visit <http://www.freescale.com>

Information in this document is provided solely to enable system and software implementers to use Freescale Semiconductor products. There are no express or implied copyright licenses granted hereunder to design or fabricate any integrated circuits or integrated circuits based on the information in this document.

Freescale Semiconductor reserves the right to make changes without further notice to any products herein. Freescale Semiconductor makes no warranty, representation or guarantee regarding the suitability of its products for any particular purpose, nor does Freescale Semiconductor assume any liability arising out of the application or use of any product or circuit, and specifically disclaims any and all liability, including without limitation consequential or incidental damages. "Typical" parameters which may be provided in Freescale Semiconductor data sheets and/or specifications can and do vary in different applications and actual performance may vary over time. All operating parameters, including "Typicals" must be validated for each customer application by customer's technical experts. Freescale Semiconductor does not convey any license under its patent rights nor the rights of others. Freescale Semiconductor products are not designed, intended, or authorized for use as components in systems intended for surgical implant into the body, or other applications intended to support or sustain life, or for any other application in which the failure of the Freescale Semiconductor product could create a situation where personal injury or death may occur. Should Buyer purchase or use Freescale Semiconductor products for any such unintended or unauthorized application, Buyer shall indemnify and hold Freescale Semiconductor and its officers, employees, subsidiaries, affiliates, and distributors harmless against all claims, costs, damages, and expenses, and reasonable attorney fees arising out of, directly or indirectly, any claim of personal injury or death associated with such unintended or unauthorized use, even if such claim alleges that Freescale Semiconductor was negligent regarding the design or manufacture of the part.

Freescale™ and the Freescale logo are trademarks of Freescale Semiconductor, Inc. All other product or service names are the property of their respective owners.  
© Freescale Semiconductor, Inc. 2004.