

N- and P-Channel 40-V Power MOSFET

GENERAL DESCRIPTION

The LT4565 is the N- and P-Channel logic enhancement mode power field effect transistors are produced using high cell density , DMOS trench technology. This high density process is especially tailored to minimize on-state resistance. These devices are particularly suited for low voltage application such as cellular phone and notebook computer power management and other battery powered circuits where high-side switching, and low in-line power loss are needed in a very small outline surface mount package.

FEATURES

- $R_{DS(ON)} \leq 40m\Omega @ V_{GS}=10V$ (N-Ch)
- $R_{DS(ON)} \leq 45m\Omega @ V_{GS}=4.5V$ (N-Ch)
- $R_{DS(ON)} \leq 54m\Omega @ V_{GS}=-10V$ (P-Ch)
- $R_{DS(ON)} \leq 60m\Omega @ V_{GS}=-4.5V$ (P-Ch)
- Super high density cell design for extremely low $R_{DS(ON)}$
- Exceptional on-resistance and maximum DC current capability

APPLICATIONS

- Power Management
- DC/DC Converter
- LCD TV & Monitor Display inverter
- CCFL inverter

PIN CONFIGURATION

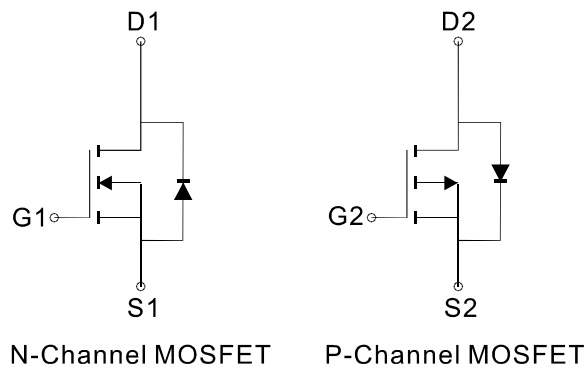
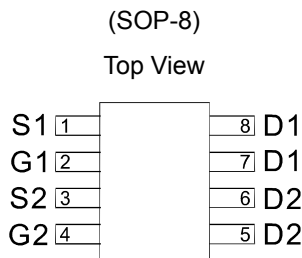

Absolute Maximum Ratings (TA=25°C Unless Otherwise Noted)

Parameter	Symbol	N-Channel		P-Channel		Unit	
		10 secs	Steady State	10 secs	Steady State		
Drain-Source Voltage	V_{DSS}	40		-40		V	
Gate-Source Voltage	V_{GSS}	± 16		± 16			
Continuous Drain Current (Tj=150°C)	I_D	$T_A=25^\circ C$	6.2	4.9	-5.3	-4.2	A
		$T_A=70^\circ C$	4.8	3.8	-4.1	-3.2	
Pulsed Drain Current	I_{DM}	25		25			
Avalanche Current	I_{AS}	13		16			
Single Pulse Avalanche Energy	E_{AS}	8.5		13		mJ	
Maximum Power Dissipation	P_D	$T_A=25^\circ C$	2.5	1.56	2.45	1.52	W
		$T_A=70^\circ C$	1.5	0.94	1.47	0.91	
Operating Junction Temperature	T_J	-55 to 150				°C	
Thermal Resistance-Junction to Ambient *	$R_{\theta JA}$	50	80	51	82	°C/W	
Thermal Resistance-Junction to Case*	$R_{\theta JC}$	49		50		°C/W	

*The device mounted on 1in² FR4 board with 2 oz copper

N- and P-Channel 40-V Power MOSFET
Electrical Characteristics ($T_A=25^\circ\text{C}$ Unless Otherwise Specified)

Symbol	Parameter	Conditions	Min	Typ	Max	Unit	
STATIC							
$V_{(BR)DSS}$	Drain-Source Breakdown Voltage	$V_{GS}=0V, I_D=250\ \mu A$ $V_{GS}=0V, I_D=250\ \mu A$	N-Ch P-Ch	40 -40		V	
$V_{GS(th)}$	Gate Threshold Voltage	$V_{DS}=V_{GS}, I_D=250\ \mu A$ $V_{DS}=V_{GS}, I_D=-250\ \mu A$	N-Ch P-Ch	0.6 -0.8	0.9 -1.0	1.6 -1.8	V
I_{GSS}	Gate Leakage Current	$V_{DS}=0V, V_{GS}=\pm 16V$ $V_{DS}=0V, V_{GS}=\pm 16V$	N-Ch P-Ch			± 100 ± 100	nA
I_{DSS}	Zero Gate Voltage Drain Current	$V_{DS}=40V, V_{GS}=0V$ $V_{DS}=-40V, V_{GS}=0V$	N-Ch P-Ch			1 -1	μA
		$V_{DS}=40V, V_{GS}=0V, T_J=55^\circ\text{C}$ $V_{DS}=-40V, V_{GS}=0V, T_J=55^\circ\text{C}$	N-Ch P-Ch			10 -10	
$I_{D(ON)}$	On-State Drain Current ^a	$V_{DS} \geq 5V, V_{GS}=10V$ $V_{DS} \leq -5V, V_{GS}=-10V$	N-Ch P-Ch	20 -20			A
$R_{DS(ON)}$	Drain-Source On-State Resistance ^a	$V_{GS}=10V, I_D=5.2A$ $V_{GS}=-10V, I_D=-4.5A$	N-Ch P-Ch		32 43	40 54	m Ω
		$V_{GS}=4.5V, I_D=4.9A$ $V_{GS}=-4.5V, I_D=-3.9A$	N-Ch P-Ch		35 48	45 60	
G_{FS}	Forward Transconductance	$V_{DS}=15V, I_D=5.2A$ $V_{DS}=-15V, I_D=-4.5A$	N-Ch P-Ch		18 13		S
V_{SD}	Diode Forward Voltage	$I_S=1.7A, V_{GS}=0V$ $I_S=-1.7A, V_{GS}=0V$	N-Ch P-Ch		0.78 -0.79	1.2 -1.2	V
DYNAMIC							
Q_g	Total Gate Charge	$V_{DS}=20V, V_{GS}=4.5V, I_D=5.2A$ N-Channel $V_{DS}=-20V, V_{GS}=-4.5V, I_D=-4.5A$ P-Channel	N-Ch P-Ch		8 12		nC
Q_{gs}	Gate-Source Charge		N-Ch P-Ch		3.3 5		
Q_{gd}	Gate-Drain Charge		N-Ch P-Ch		2.8 5.2		
R_g	Gate Resistance	$V_{GS}=0V, V_{DS}=0V, f=1\text{MHz}$	N-Ch P-Ch		0.7 4.5		Ω
C_{iss}	Input capacitance	$V_{DS}=20V, V_{GS}=0V, F=1\text{MHz}$ N-Channel $V_{DS}=-20V, V_{GS}=0V, F=1\text{MHz}$ P-Channel	N-Ch P-Ch		500 1000		pF
C_{oss}	Output Capacitance		N-Ch P-Ch		43 81		
C_{rss}	Reverse Transfer Capacitance		N-Ch P-Ch		9.3 22		
$t_{d(on)}$	Turn-On Delay Time	$V_{DD}=15V, R_L=15\ \Omega$ $I_D=1A, V_{GEN}=10V, R_G=6\ \Omega$ P-Channel $V_{DD}=-15V, R_L=15\ \Omega$ $I_D=-1A, V_{GEN}=-10V, R_G=6\ \Omega$	N-Ch P-Ch		8 30		ns
t_r	Turn-On Rise Time		N-Ch P-Ch		15 12		
$t_{d(off)}$	Turn-Off Delay Time		N-Ch P-Ch		36 62		
t_f	Turn-On Fall Time		N-Ch P-Ch		2 5		

 Notes: a. Pulse test; pulse width $\leq 300\ \mu s$, duty cycle $\leq 2\%$

N- and P-Channel 40-V Power MOSFET

Typical Characteristics (T_J = 25°C Noted)

N-CHANNEL

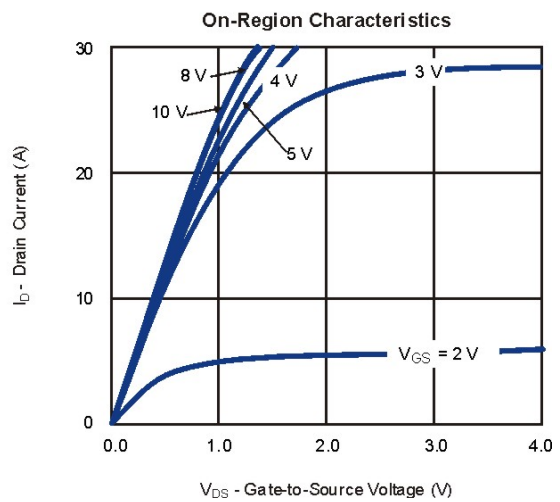
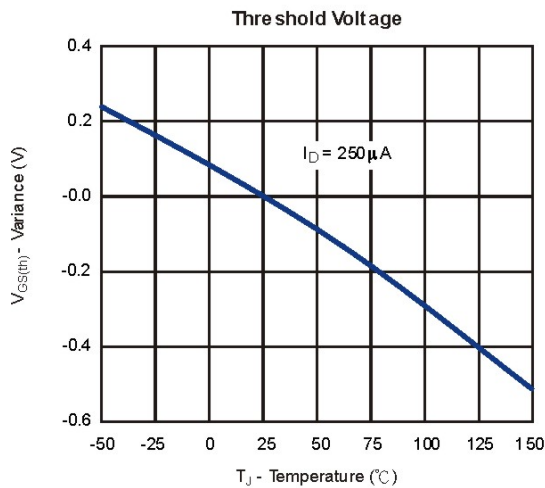
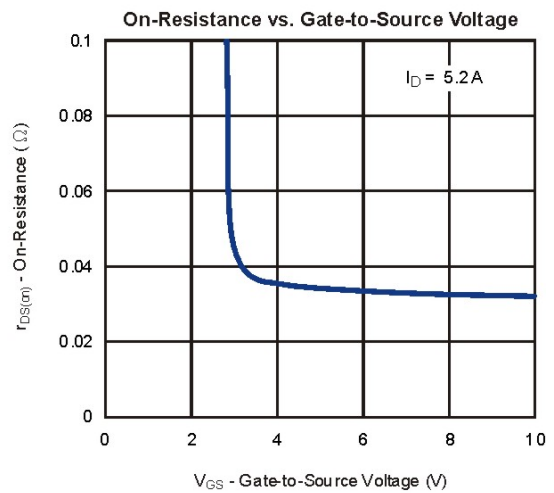
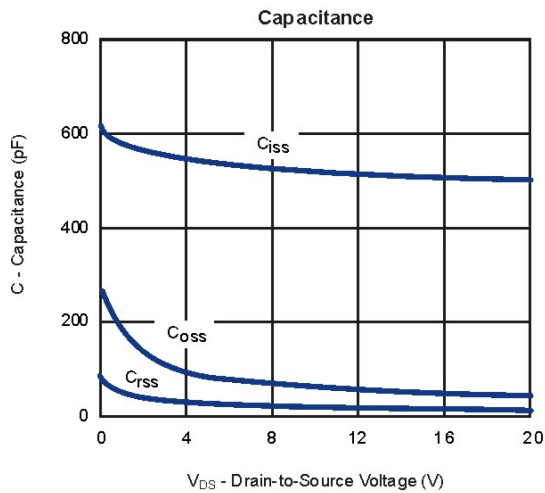
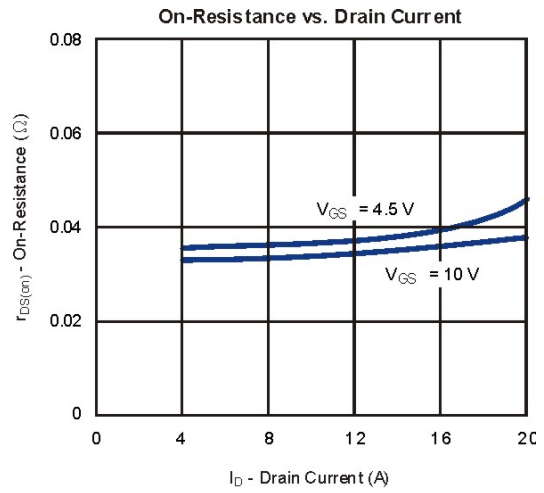
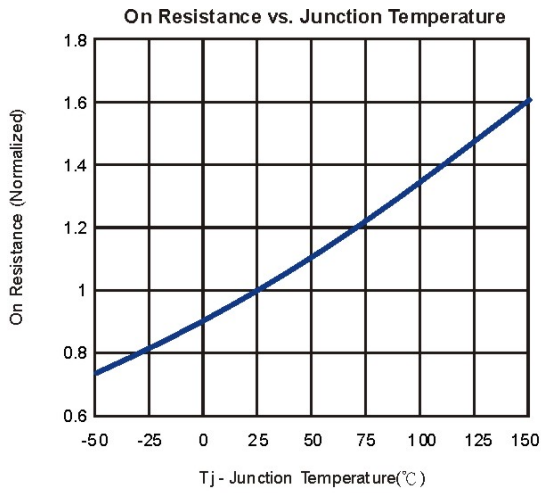

N- and P-Channel 40-V Power MOSFET

Typical Characteristics (T_J = 25°C Noted)

N-CHANNEL

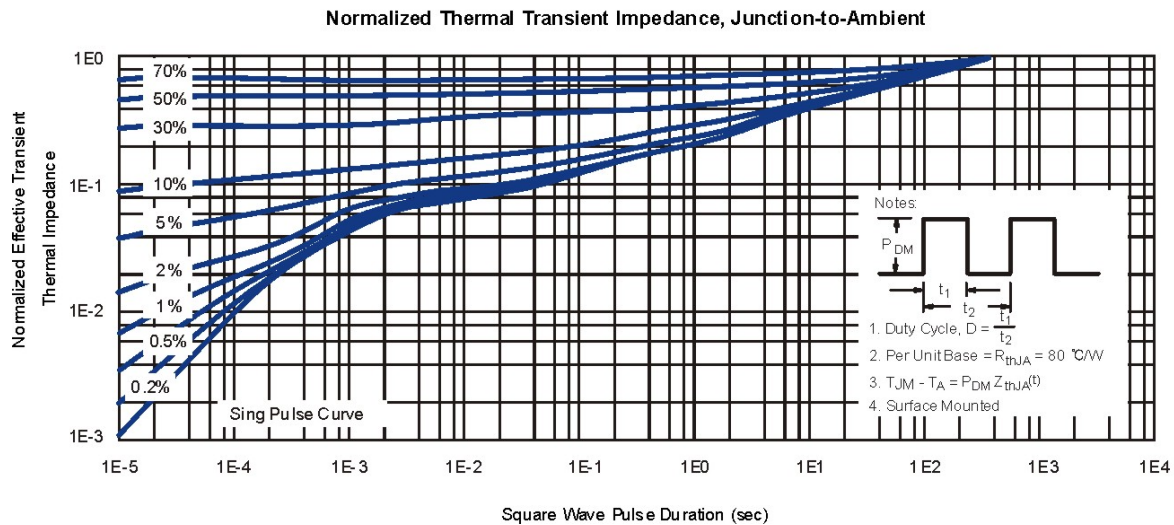
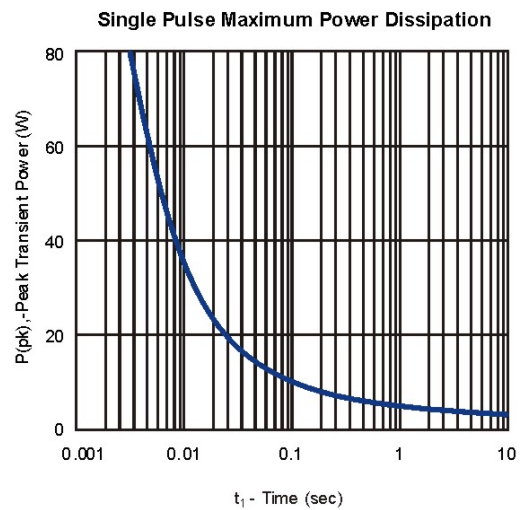
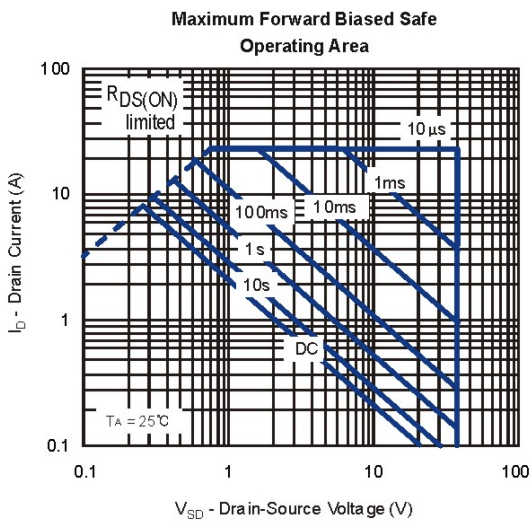
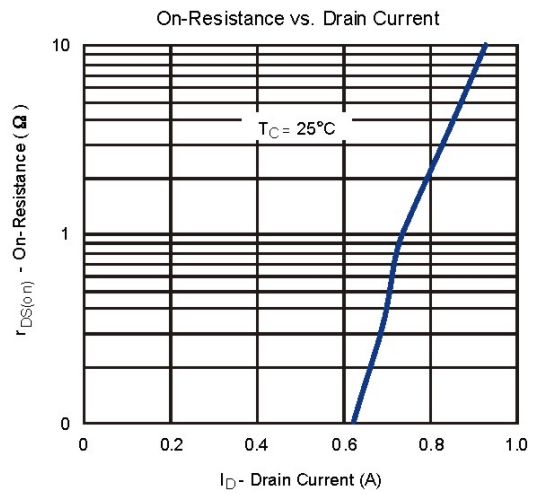
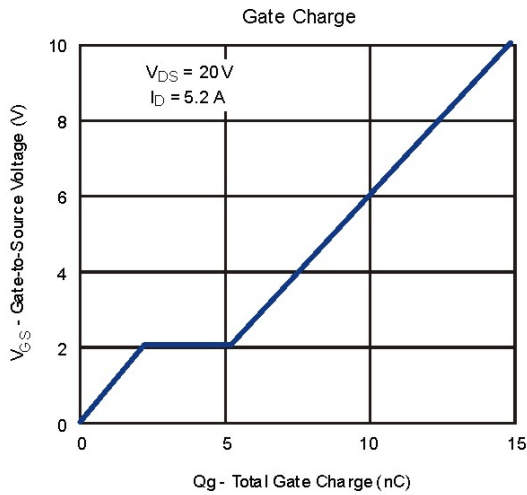

N- and P-Channel 40-V Power MOSFET

Typical Characteristics (T_J = 25°C Noted)

P-CHANNEL

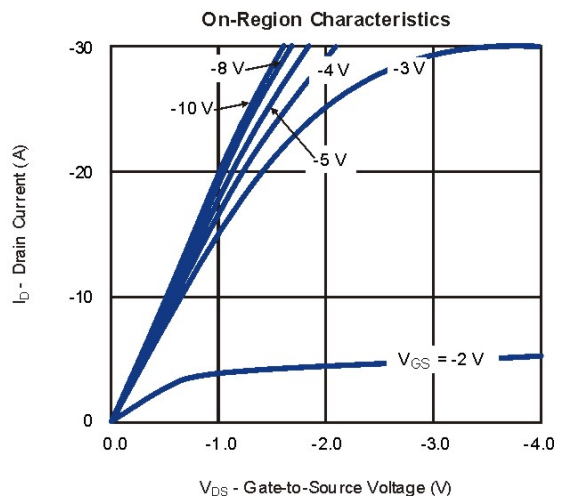
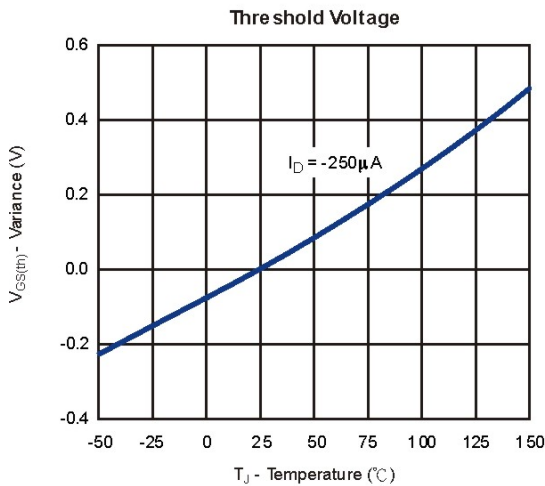
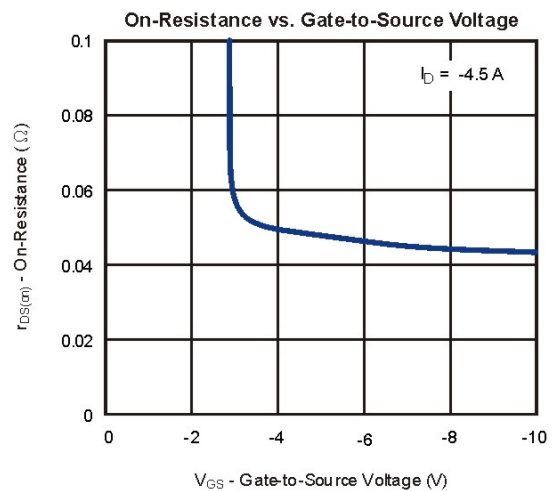
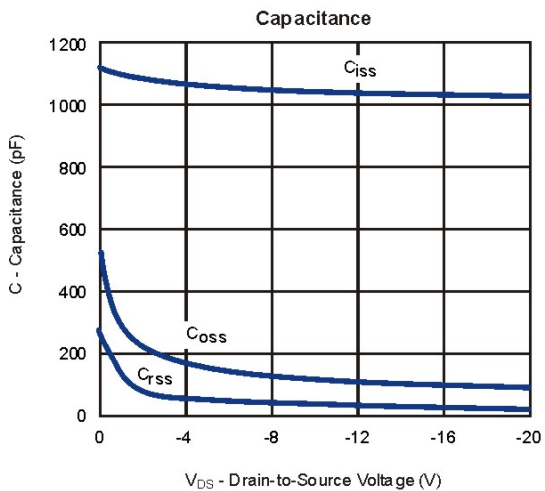
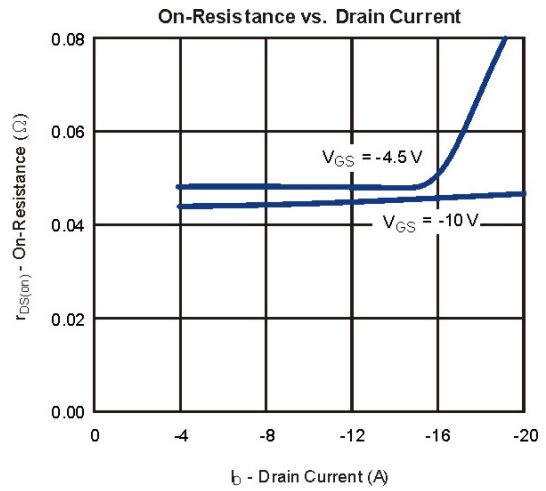
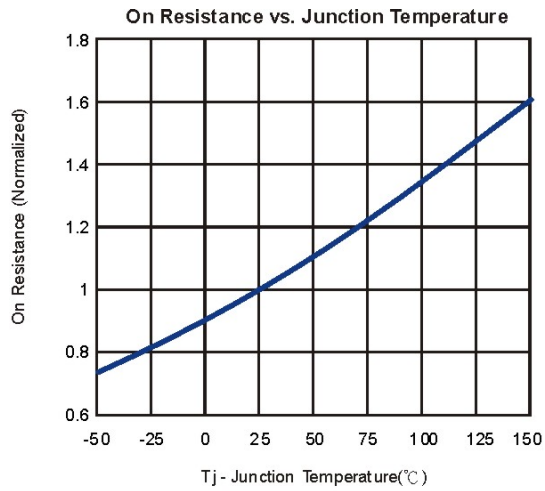

N- and P-Channel 40-V Power MOSFET

Typical Characteristics (T_J = 25°C Noted)

P-CHANNEL

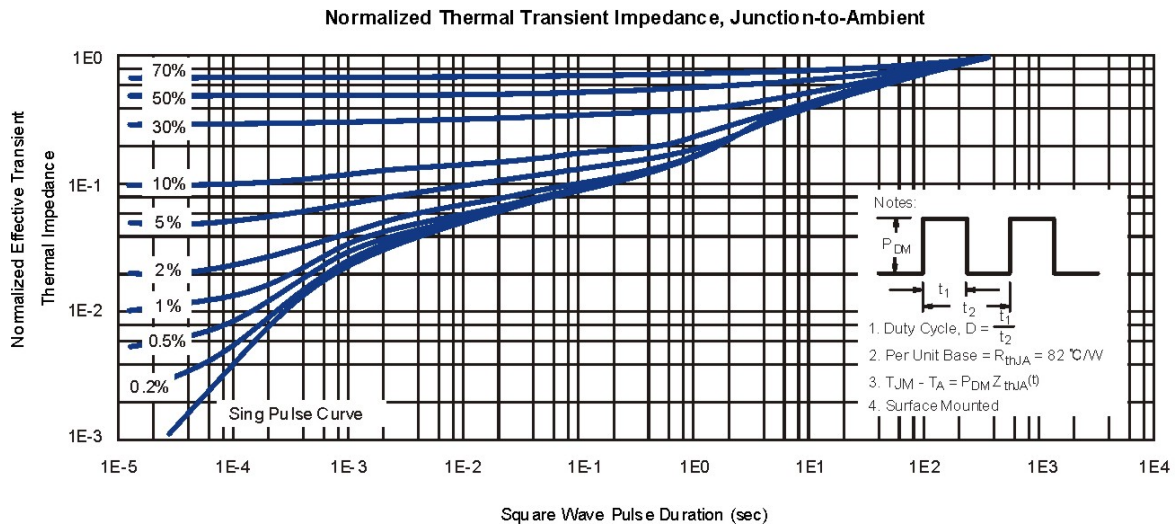
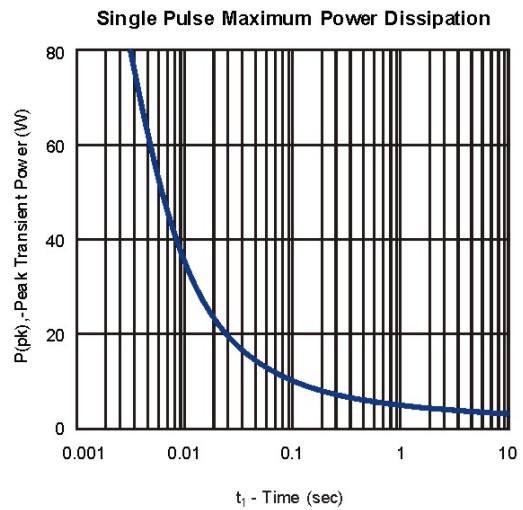
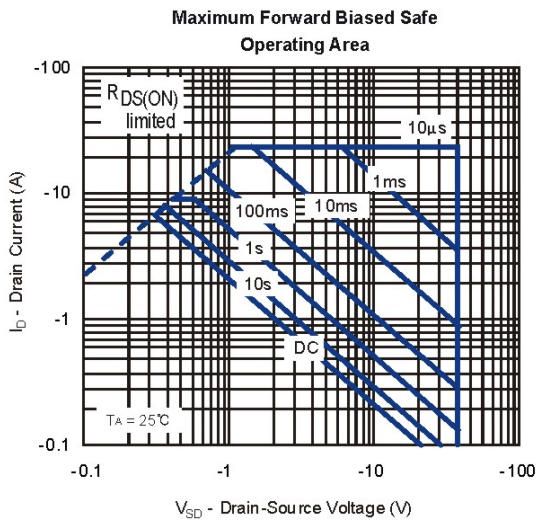
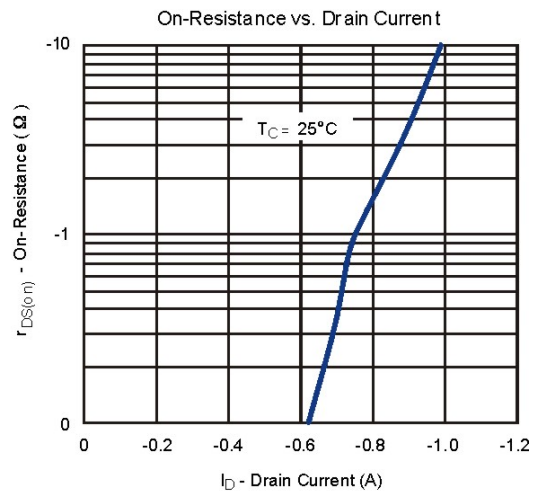
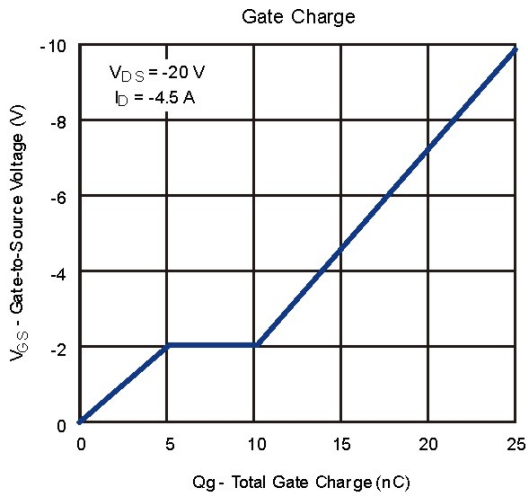

N- and P-Channel 40-V Power MOSFET

SOP-8 Package Outline

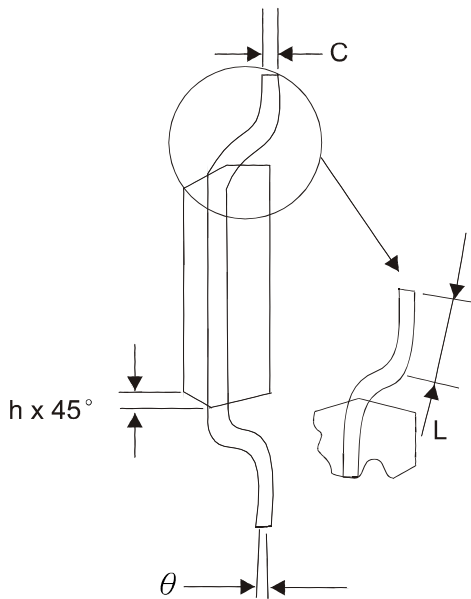
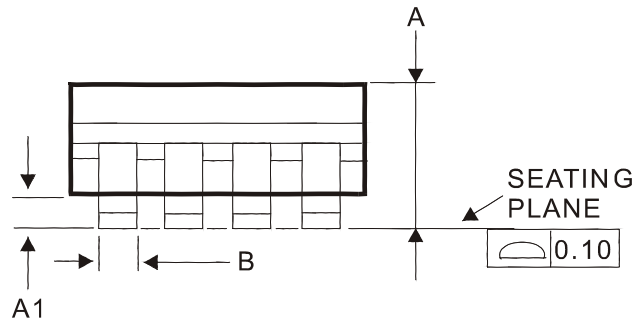
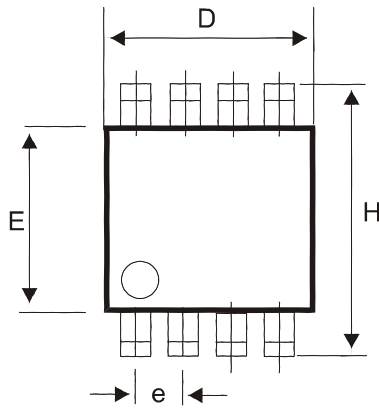

DIM	MILLIMETERS	
	MIN	MAX
A	1.35	1.75
A1	0.10	0.25
B	0.35	0.49
C	0.18	0.25
D	4.80	5.00
E	3.80	4.00
e	1.27 BSC	
H	5.80	6.20
h	0.25	0.50
L	0.40	1.25
θ	0°	7°