

Single-phase DC Brushless Motor Driver IC

■ GENERAL DESCRIPTION

The NJU7346 is a single-phase DC brushless motor driver IC. It features MOS-FET driver circuit for better saturation characteristics.

It features Frequency Generator Output and Thermal Shutdown Circuit.

Maximum output current is 200mA(12V). Input offset voltage is $\pm 7\text{mV}$.

It is suitable for 12V high current small fan-motor applications.

■ PACKAGE OUTLINE

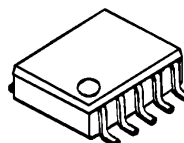

NJU7346R

■ FEATURES

- Operating Voltage 3.5 to 14V
- Frequency Generator Output
- Thermal Shutdown Circuit
- Low Operating Current
- Low Saturation Output Voltage
- $V_{\text{sat}} = \pm 0.3\text{V}$ @ $I_{\text{o}} = \pm 200\text{mA}$
- CMOS Technology
- Package Outline VSP10

■ BLOCK DIAGRAM

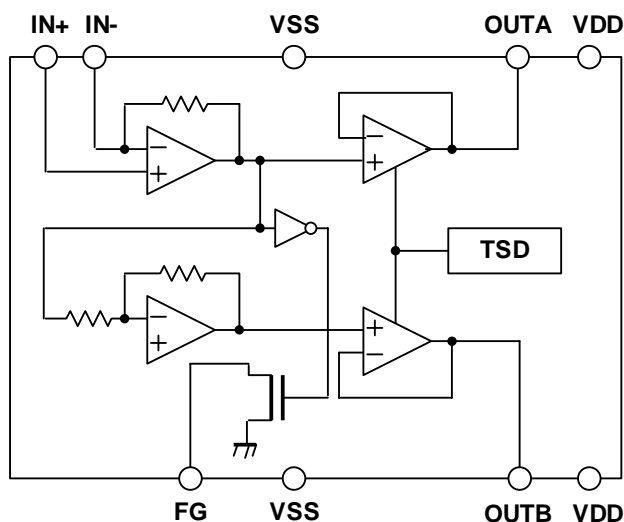

NJM7346

■ PIN FUNCTION

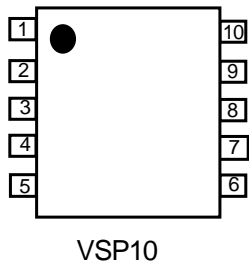

1:NC
 2:FG
 3:V_{SS}
 4:OUTB
 5:V_{DD}
 6:V_{DD}
 7:OUTA
 8:V_{SS}
 9:IN-
 10:IN+

(Note)

All V_{DD} and V_{SS} pins should be connected the power supply and the ground respectively. Otherwise, the electrical characteristic may not satisfy specifications

■ ABSOLUTE MAXIMUM RATINGS

(Ta=25°C)

PARAMETER	RATINGS	SYMBOL (unit)	NOTE
Supply Voltage	+15.0	V _{DD} (V)	
Input Voltage	-0.3 ~ V _{DD}	V _{ID} (V)	
Output Current (Peak)	600	I _{OPEAK} (mA)	
Operating Temperature Range	-40 ~ +85	T _{opr} (°C)	
Storage Temperature Range	-50 ~ +150	T _{stg} (°C)	
Power Dissipation	400	P _D (mW)	Device itself

■ RECOMMENDED OPERATING CONDITIONS

(V_{DD}=12V, Ta=25°C)

PARAMETER	SYMBOL	CONDITION	MIN.	TYP.	MAX.	UNIT
Supply Voltage	V _{DD}	-	3.5	-	14	V
Output Current	I _O	-	-	-	200	mA

■ ELECTRICAL CHARACTERISTICS

($V_{DD}=12V, T_a=25^{\circ}C$)

PARAMETER	SYMBOL	CONDITION	MIN.	TYP.	MAX.	UNIT
General						
Operating Current	I_{DD}	-	-	3.0	4.0	mA
Thermal Shutdown Temperature	T_{TSD}	-	-	180	-	$^{\circ}C$
Thermal Shutdown Hysteresis	T_{HYS}	-	-	60	-	$^{\circ}C$
Hall Amplifier						
Input Offset Voltage	V_{IO}	-	-18	-	18	mV
Feedback Resistance	R_F	-	-	37.5	-	k Ω
Input Common Mode Voltage Range	V_{ICM}	-	0.2~10.5	-	-	V
Output						
Maximum Output Voltage Range	V_{OH}	$I_o=+200mA$	11.55	11.70	-	V
	V_{OL}	$I_o=-200mA$	-	0.30	0.45	
Output Resistance	R_{ONH}	$I_o=+200mA$	-	1.5	-	Ω
	R_{ONL}	$I_o=-200mA$	-	1.5	-	
FG L Output Voltage	V_{FG}	$I_{FGL}=5mA$	-	-	0.6	V
FG H Leak Current	$I_{FG-LEAK}$	$V_{FGL}=12V$	-	-	1.0	μA

■ INPUT-OUTPUT TRUTH TABLE

Input		Output		
IN+	IN-	OUTA	OUTB	FG
H	L	H	L	H
L	H	L	H	L

NJM7346

POWER DISSIPATION

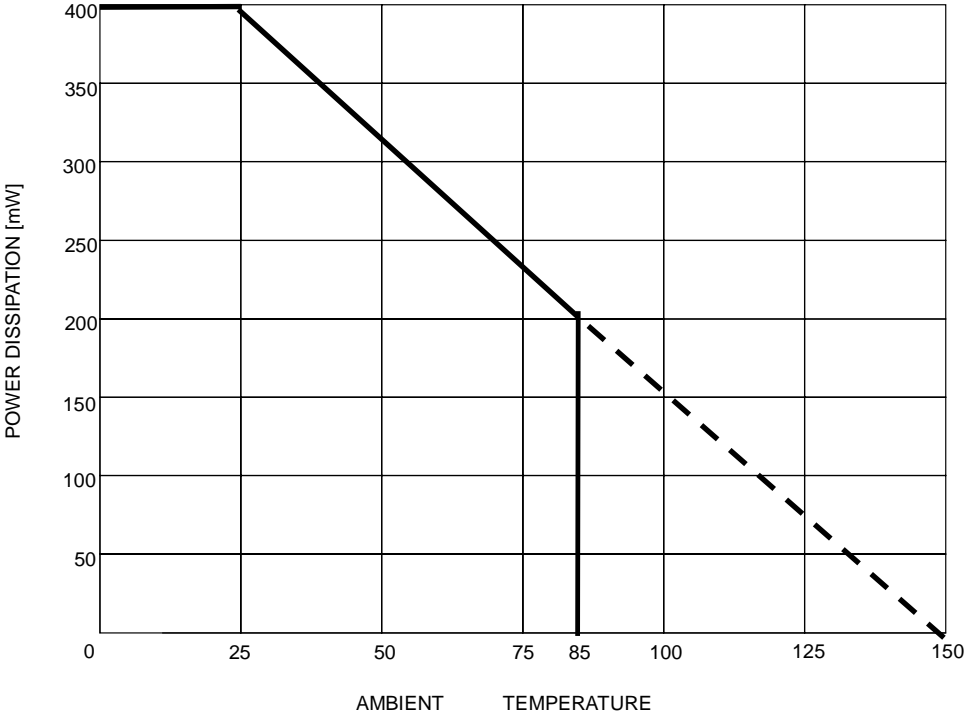
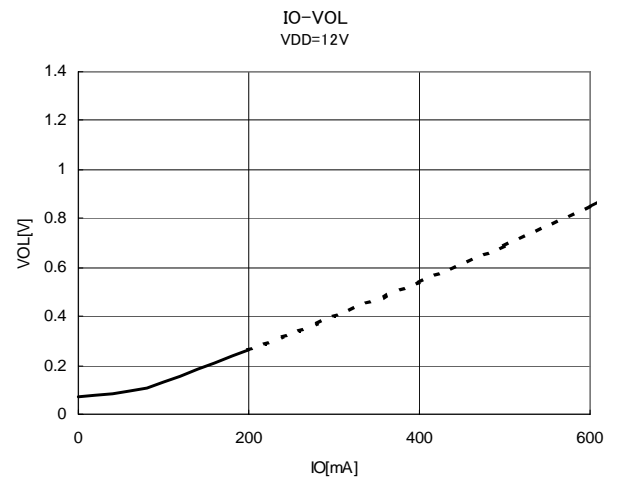
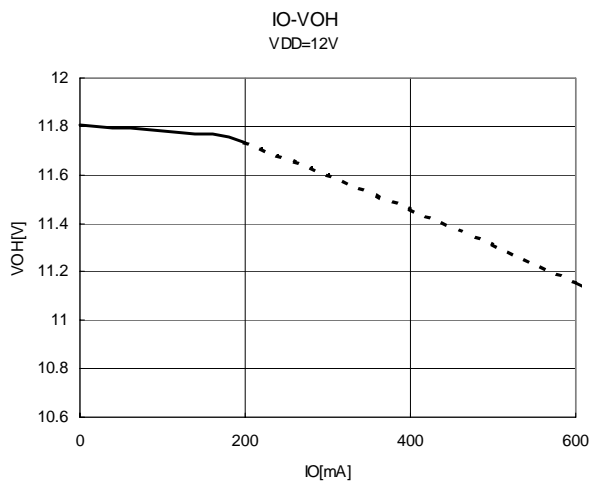
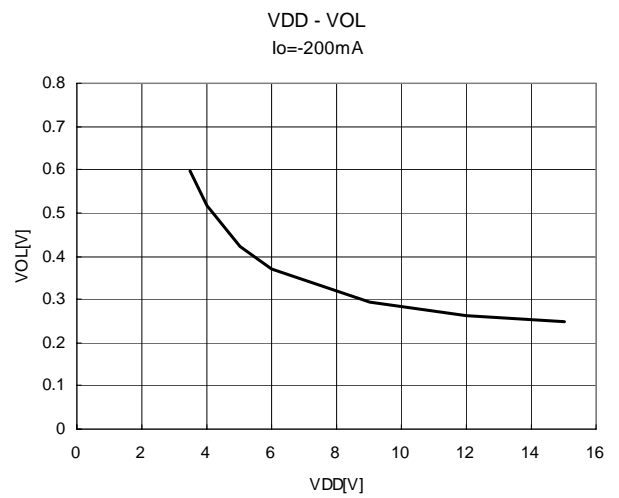
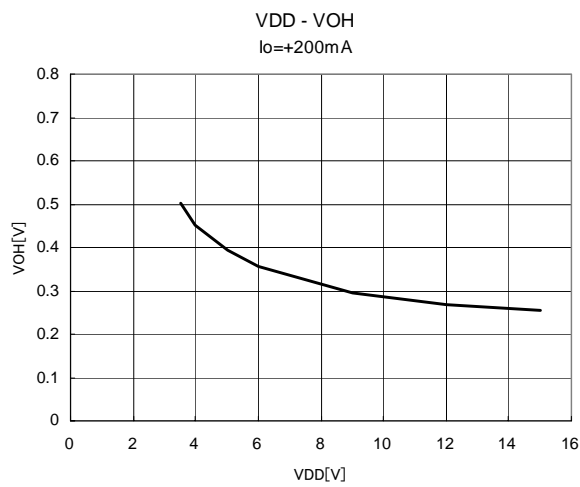
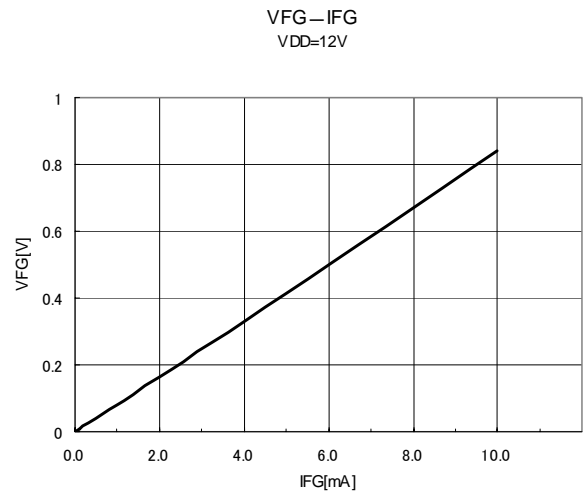
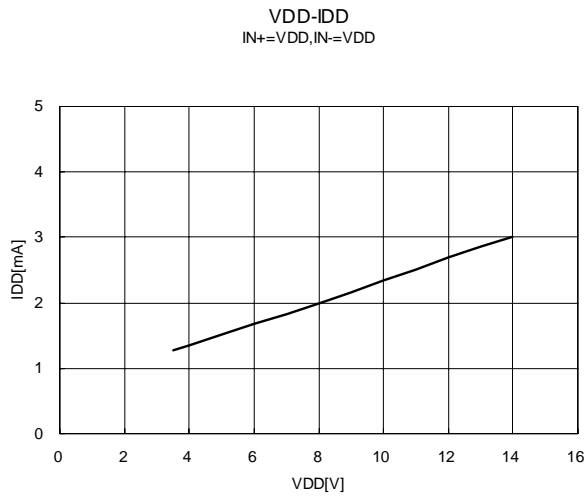

FIG. 21

TYPICAL CHARACTERISTICS



NJM7346

APPLICATION NOTE

The NJU7346 is a single-phase DC brushless motor driver IC in small VSP10 package.
With minimal external components, It can drive up to 200mA of motor current for small fan application.

[Application Circuit Example]

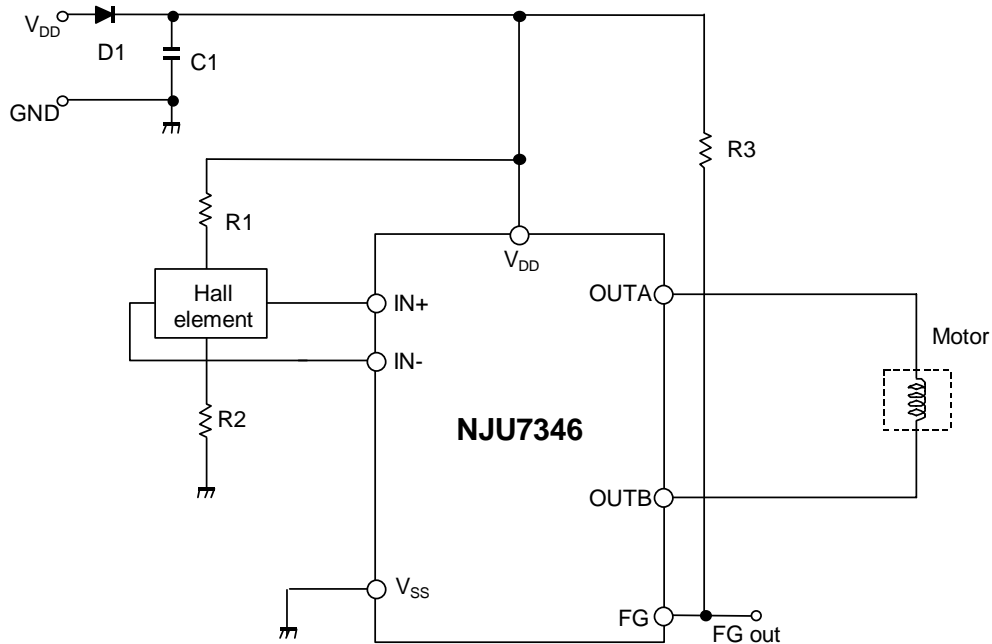

[Design Notes]

Above application example is designed for 12V operation with motor current of 200mA. It uses the following components:

Hall elements: HW101A (AKE)

1. Selection of **C1** and **D1**:

C1 is used for a noise reduction purpose. A typical value is 0.1 μ F.

Optimize the value in actual operating conditions if necessary. D1 is a diode for protection against reverse voltage supply. Silicon rectifier diode (WO3C, 10D1 and equivalent) is appropriate.

2. Design of hall element bias resistance (**R1** and **R2**)

Hall amplifier is a differential amplifier.

The common-mode input voltage is between 0.2V and $V_{DD}-1.5V$ and the input signal must be within the range. Non-excitation hall bias voltage is to be set at a half of V_{DD} for effective use of common-mode input voltage range. Therefore the same value of hall bias resistors is selected for R1 and R2.

Given that the bias current is set to be 5mA by HW101A datasheet, R1 and R2 can be determined as follows:

$$R1 + R2 + Rin = \frac{V_{DD}}{I_{bias}} = \frac{12}{5 \times 10^{-3}} = 2.4k\Omega$$

$$R1 = R2 = 1k\Omega$$

The output voltage of hall elements is influenced by the bias current and magnetic flux density of hall elements.

The optimum input voltage of NJU7346 is 100mVp-p and higher. With such input voltage, the highest efficiency can be obtained.

3. Design of FG output resistance (R3)

FG Out(FG:Pin2) is a open drain output and R3 is a pull up register. A typical value of R3 is 10kΩ. The timing chart of FG Out is as follows.

Note that the pull up resistance shall be connected to below supply voltage.

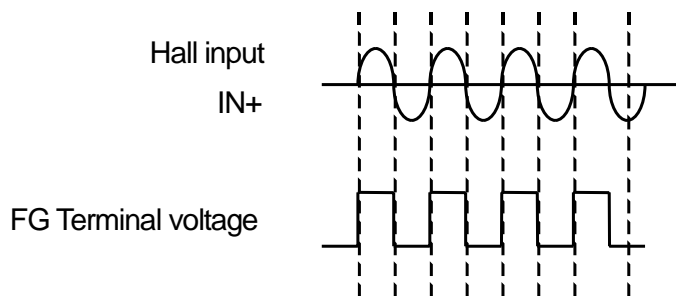

[CAUTION]

The specifications on this databook are only given for information, without any guarantee as regards either mistakes or omissions. The application circuits in this databook are described only to show representative usages of the product and not intended for the guarantee or permission of any right including the industrial rights.