

Single-phase DC Brushless Motor Driver IC

■ GENERAL DESCRIPTION

The NJU7361 is single-phase DC brushless motor driver IC. And It features MOS-FET driver circuit for better output characteristics.

NJU7361 features Frequency Generator Output, Thermal Shutdown Circuit, Hall Bias Terminal and PWM_IN INPUT for Rotation Speed Control.

Maximum output current is 700mA and Continuance output current is 250mA.

It is suitable for variable speed FAN required Low Noise & Good Efficiency characteristics.

■ PACKAGE OUTLINE

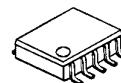

NJU7361RB2

■ FEATURES

- Operating Voltage $V_{DD} = 2.4 \sim 5.5V$
- Low Operating Current $I_{DD} = 1mA(Typ.)$
- Low Saturation Output Voltage
 $V_{OM} = \pm 0.30V @ I_o = \pm 250mA$
- PWM_IN Input
- Hall Bias Terminal
- Frequency Generator Output
- Thermal Shutdown Circuit
- CMOS Technology
- Package Outline TVSP 10

■ BLOCK DIAGRAM

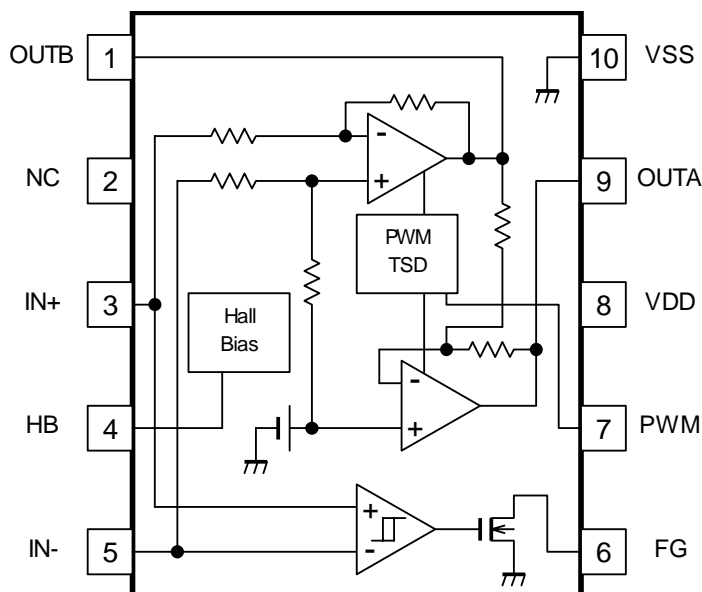

■ PIN CONFIGURATION

PIN NUMBER	PIN NAME
1	OUTB
2	NC
3	IN+
4	HB
5	IN-
6	FG
7	PWM
8	VDD
9	OUTA
10	VSS

NJU7361

■ ABSOLUTE MAXIMUM RATINGS

(Ta=25°C)

PARAMETER	SYMBOL	RATINGS	UNIT
Supply Voltage	V _{DD}	+7.0	V
Input Voltage	V _{ID}	-0.3 ~ V _{DD} (*1)	V
Output Current (Peak)	I _{OPEAK}	700(*2)	mA
FG Output Current	I _{FG}	10	mA
FG Output Voltage	V _{FG}	+7.0	V
Operating Temperature Range	T _{opr}	-40 ~ +85	°C
Storage Temperature Range	T _{stg}	-50 ~ +150	°C
Power Dissipation	P _D	400(*3)	mW
Junction Temperature	T _{jmax}	+150	°C

(*1) Input voltage is not to be over supply voltage to really use.

(*2) This value is not to be over P_D.

(*3) Device itself

■ OPERATING CONDITIONS

(Ta=25°C)

PARAMETER	SYMBOL	CONDITION	MIN.	TYP.	MAX.	UNIT
Supply Voltage	V _{DD}	-	2.2	5.0	5.5	V

■ ELECTRICAL CHARACTERISTICS

(V_{DD}=5V, Ta=25°C)

PARAMETER	SYMBOL	CONDITION	MIN.	TYP.	MAX.	UNIT
General						
Operating Current	I _{DD}	IN+=5V, IN-=0V	-	1.0	2.0	mA
Thermal Shutdown Temperature	T _{TSD}	-	-	180	-	°C
Thermal Shutdown Hysteresis	T _{HYS}	-	-	50	-	°C
Hall Amplifier						
Input Offset Voltage	V _{IO}	-	-10	-	10	mV
Close Loop Gain	A _V	-	-	44	-	dB
Input Common Mode Voltage Range	V _{ICM}	-	0.4	-	4.0	V
Output						
Maximum Output Voltage Range	V _{OH}	I _O =250mA	4.55	4.70	-	V
	V _{OL}	I _O =-250mA	-	0.30	0.45	
FG L Output Voltage	V _{FG}	I _{FG} =3mA	-	-	0.3	V
FG H Leak Current	I _{FG-LEAK}	V _{FG} =5V	-	-	1.0	μA
Hall Bias						
Hall Bias Voltage	V _{HB}	I _{HB} =5mA	1.0	1.3	1.5	V
PWM Input						
PWM Input Frequency Ratio	f _{PWM}	-	-	-	50	kHz
PWM pull-up Resistance	R _{PWM}	-	-	50	-	kΩ
Input H Level Voltage	V _{IHP}	-	0.7V _{DD}	-	V _{DD}	V
Input L Level Voltage	V _{ILP}	-	0	-	0.3V _{DD}	V

■ INPUT-OUTPUT TRUTH TABLE

No.	IN+	IN-	PWM	TSD	OUTA	OUTB	FG
1	H	L	H	OFF	H	L	L
2	L	H	H	OFF	L	H	Z
3	H	L	L	OFF	Z	L	L
4	L	H	L	OFF	L	Z	Z
5	H	L	H	ON	Z	L	L
6	L	H	H	ON	L	Z	Z
7	H	L	L	ON	Z	L	L
8	L	H	L	ON	L	Z	Z

* Z : High-impedance

■ TIMING CHART

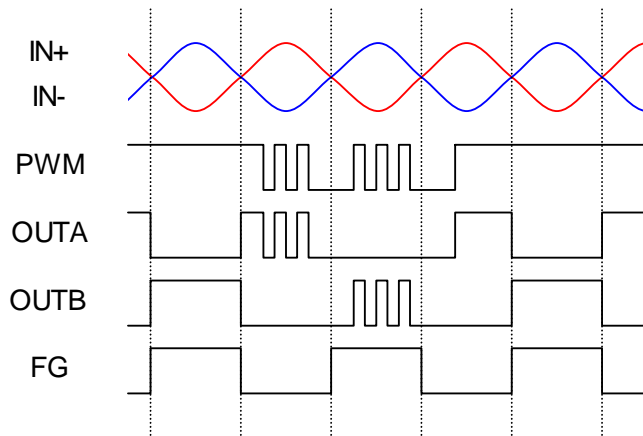

■ DERATING CURVE

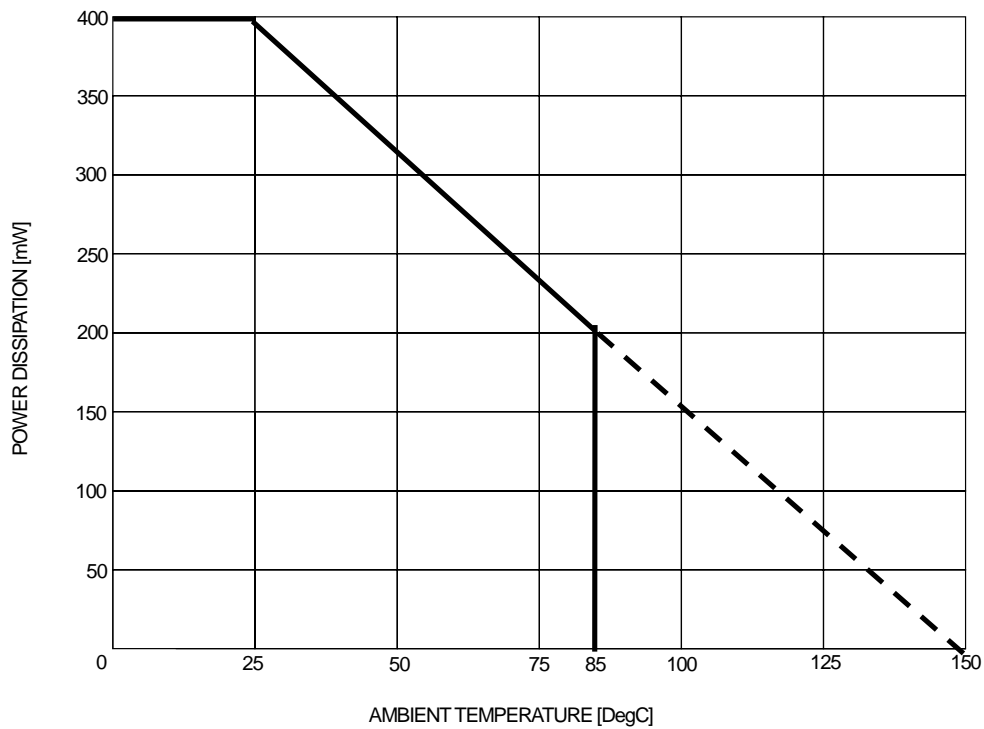

■ ELECTRICAL CHARACTERISTICS

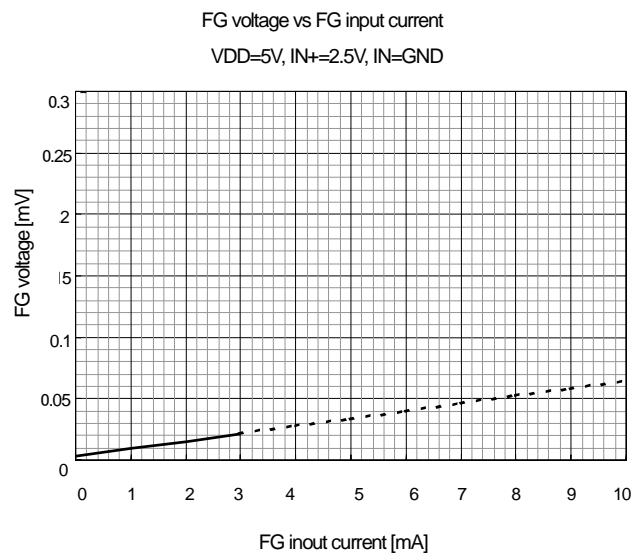
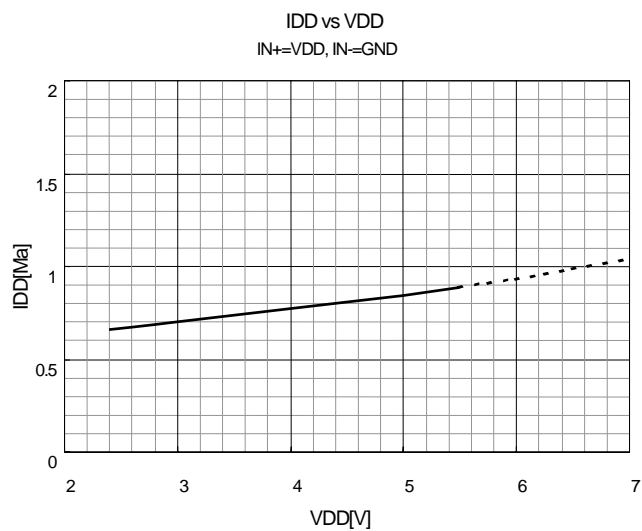

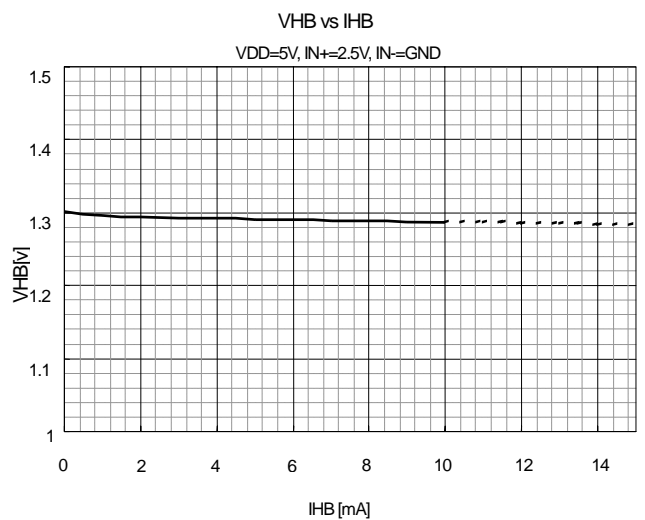
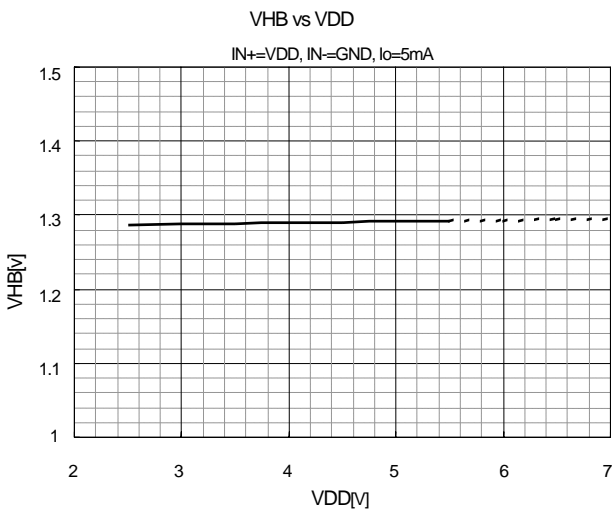
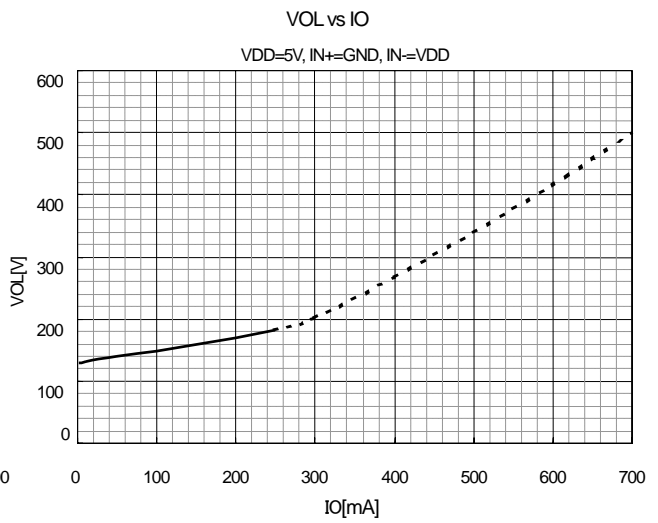
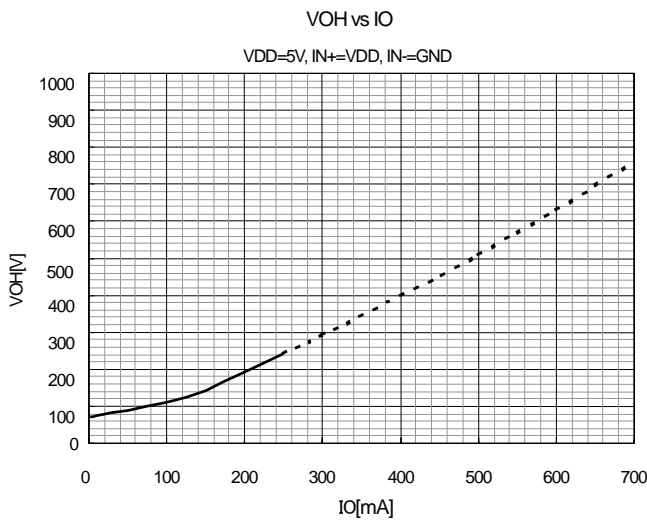
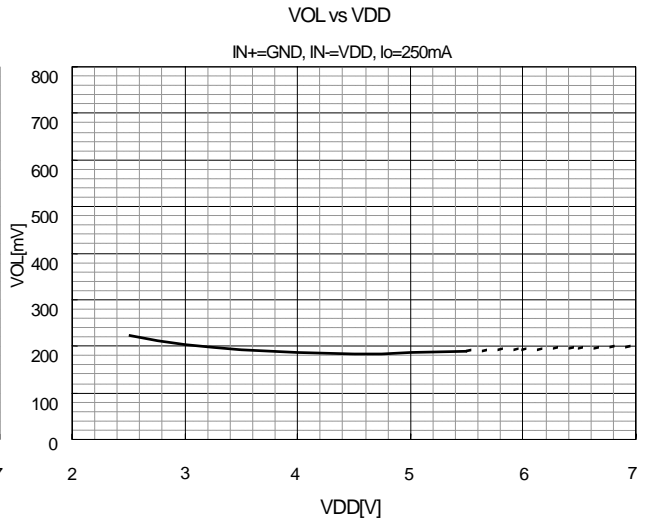
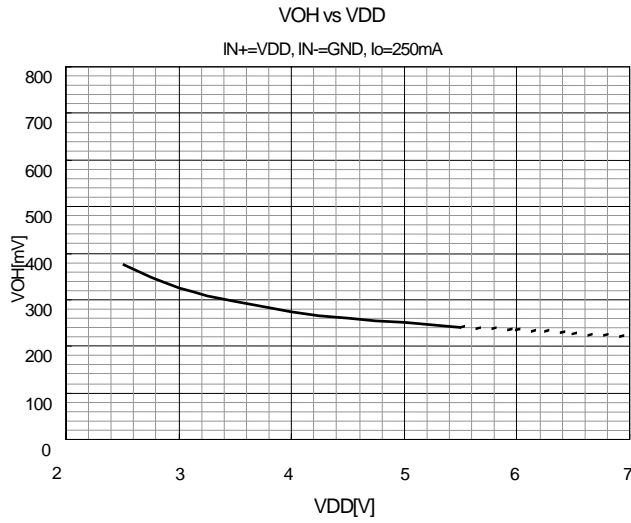

■ APPLICATION NOTE

The NJU7360 are single-phase DC brushless motor driver IC in small TVSP8 package. With minimal external components, that can drive up to 250mA of motor current for small fan application.

[Application Circuit Example]

1) Hall Bias unused application circuit

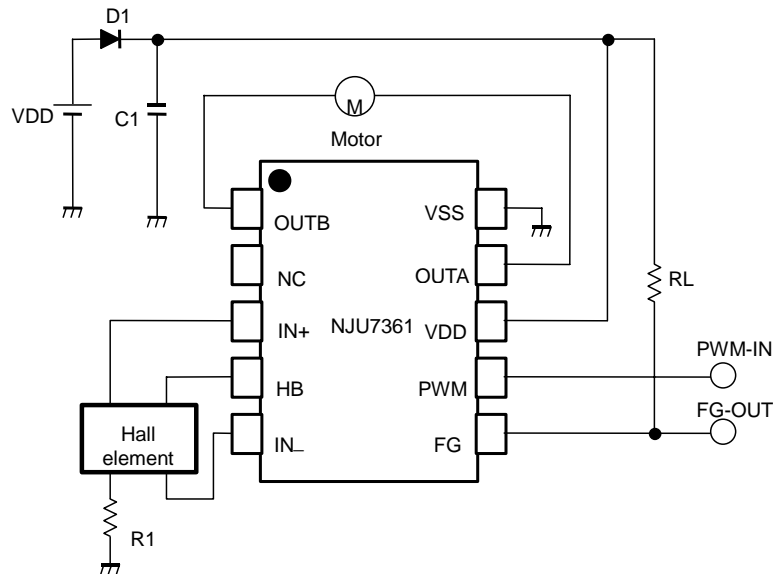

[Design Notes]

Above application example is designed for 5V operation with motor current of 250mA. It uses the following components:

Hall elements: HW101A (AKE)

1. Selection of C1 and D1:

C1 is used for a noise reduction purpose. A typical value is 0.1 μ F.

Optimize the value in actual operating conditions if necessary. D1 is a diode for protection against reverse voltage supply. Silicon rectifier diode (WO3C, 10D1 and equivalent) is appropriate.

2. Position Detection Circuit Hall Device

2-1. When using HB (R1 design)

By connecting a Hall device to the Hall bias terminal (HB), a constant Hall output amplitude that has good temperature characteristics is obtained, resulting in stable linear drive. If it is necessary to adjust the Hall output amplitude, perform adjustment with R1.

2-2. When using V_{DD} (R2 and R3 design)

When it is necessary to increase the Hall bias current to increase the Hall output amplitude, obtain Hall bias from V_{DD} . The input bias voltage for the amplifier must be used within the Hall input common mode voltage ($0.4 - V_{DD} - 1$ V) including the amplitude of the signal. It is recommended that the Hall bias voltage be one half of the power supply voltage, that is, $V_{DD}/2$.

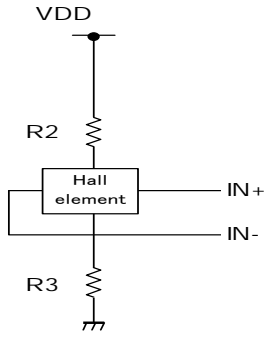

3. Design of FG output resistance (R_L)

FG Out (FG: Pin5) is an open drain output and R_L is a pull up register. A typical value of R_L is 10k Ω .

[CAUTION]
 The specifications on this databook are only given for information, without any guarantee as regards either mistakes or omissions. The application circuits in this databook are described only to show representative usages of the product and not intended for the guarantee or permission of any right including the industrial rights.