



## INFRARED REMOTE CONTROL RECEIVER

### ■ GENERAL DESCRIPTION

NJL50H/V000A series are small and high performance receiving devices for infrared remote control system. Regarding the transmission distance, NJL50H/V000A is longer than NJL50H/V000. The pulse width of NJL50H/V000A series are stable relating to commander's power or distance between transmitter and receiver. NJL50H/V000A series have five kinds of package including three types of metal case to meet the various applications.

### ■ FEATURES

1. Mold type and metal case type to meet the design of front panel.
2. Elliptic lens to improve the characteristic against light noise from the upper and lower side.
3. Line-up for various center carrier frequencies.

### ■ APPLICATIONS

1. AV instruments such as Audio, TV, VCR, CD, MD, etc.
2. Home appliances such as Air-conditioner, Fan, etc.
3. The other equipments with wireless remote control.

### ■ LINE-UP

Mold/ Metal Case	Mold Type		Metal Case Type		
	Top	Side	Top		
View					
Height	5.4 mm	6.3 mm	8 mm	11 mm	15 mm
Carrier Frequency					
fo=30 KHz	NJL51H300A	NJL51V300A	NJL57H300A	NJL55H300A	NJL56H300A
32.75KHz	NJL51H328A	NJL51V328A	NJL57H328A	NJL55H328A	NJL56H328A
36 KHz	NJL51H360A	NJL51V360A	NJL57H360A	NJL55H360A	NJL56H360A
36.7 KHz	NJL51H367A	NJL51V367A	NJL57H367A	NJL55H367A	NJL56H367A
38 KHz	NJL51H380A	NJL51V380A	NJL57H380A	NJL55H380A	NJL56H380A
40 KHz	NJL51H400A	NJL51V400A	NJL57H400A	NJL55H400A	NJL56H400A
56.8 KHz	NJL51H568A	NJL51V568A	NJL57H568A	NJL55H568A	NJL56H568A

※ Regarding the other frequencies or packages, please contact to NJRC individually.

6

### ■ BLOCK DIAGRAM

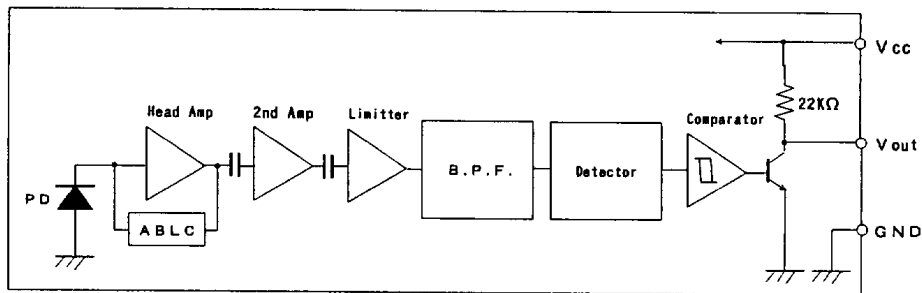

### ■ ABSOLUTE MAXIMUM RATINGS (Ta = 25 °C)

Supply Voltage	V <sub>CC</sub>	6.3V
Operating Temperature Range	T <sub>opr</sub>	-30 °C — +85 °C
Storage Temperature Range	T <sub>stg</sub>	-40 °C — +85 °C
Soldering Temperature	T <sub>sol</sub>	260 °C 5sec 4.0mm from mold body



■ RECOMMENDED OPERATING CONDITION

Supply Voltage Range  $V_{cc}$  4.5V – 5.5V

■ ELECTRO-OPTICAL CHARACTERISTICS ( $V_{cc} = 5.0V$ ,  $T_a = 25^\circ C$ )

PARAMETER	SYMBOL	TEST CONDITION	MIN	TYP	MAX	UNIT
Supply Current	$I_{cc}$	No Signal Input	—	—	3	mA
Transmission Distance	$L_c$	Direction of Ray Axis *1	13	18	—	m
Directivity	$\theta_L$	Angle of half $L_c$ , Horizontal *2	—	50	—	deg
	$\theta_V$	Angle of half $L_c$ , Vertical *2	—	35	—	deg
Output Voltage Low	$V_L$	No Load	—	0.2	0.5	V
Output Voltage High	$V_H$	No Load	4.5	—	—	V
Low Level Pulse Width	$T_{WL}$	See Test Circuit	400	—	800	$\mu s$
High Level Pulse Width	$T_{WH}$	See Test Circuit	400	—	800	$\mu s$
Center Frequency	$f_o$	See Line-up	30.0	—	56.8	KHz

Note \*1: Test with each center carrier frequency under the test condition shown below.

\*2: Place major axis of elliptic lens in horizontal direction and minor in vertical.

■ TEST METHOD

Test condition is as follows:

( 1 ) Standard Transmitter:

Transmitting waveform is shown in Fig.1. Transmitting power should be adjusted so that output voltage  $V_{out}$  will be 400 mVp-p.

Regarding IR LED used for transmitter,  
 $\lambda_p = 940nm$ ,  $\Delta \lambda = 50nm$ .

Regarding photo diode, Sensitivity  
 $S = 26nA/Lx$ , in case light source  
 temperature 2856 °K,  $E_e = 100Lx$ ,  $VR = 5V$

( 2 ) Test system: Shown in Fig.3.

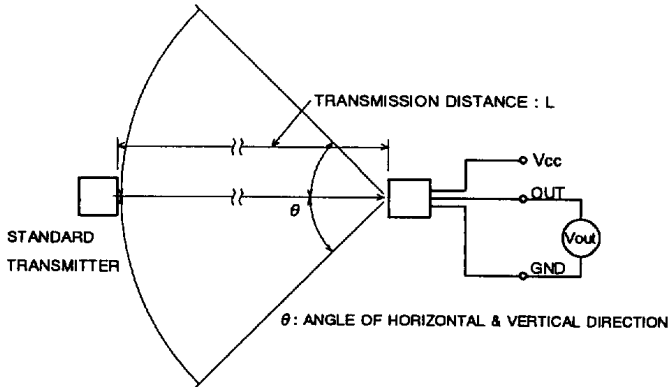

Fig. 3 TEST SYSTEM

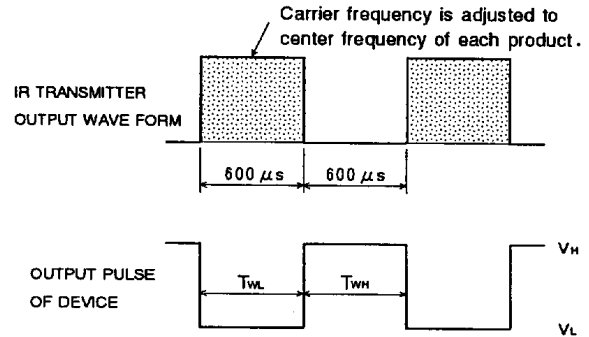

Fig. 1 TRANSMITTER WAVE FORM

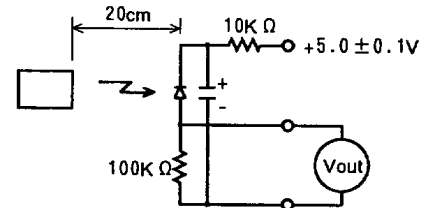

Fig. 2 STD. TRANSMITTER TEST CIRCUIT

6



## ■ TYPICAL CHARACTERISTICS

**Spectral Response**  
( $T_a=25^\circ\text{C}$ )

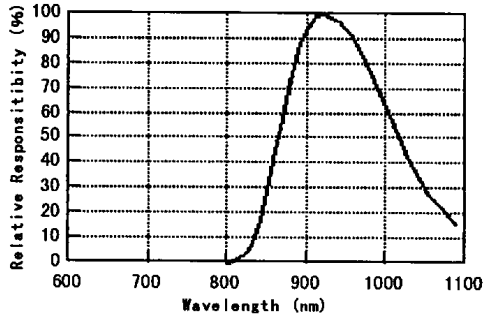

**Directivity**  
( $T_a=25^\circ\text{C}$ )

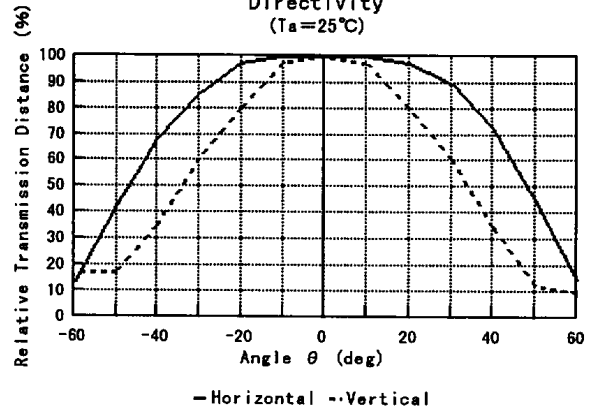

**Output Pulse Width vs. Distance**  
(Input Pulse Width=600  $\mu\text{s}$ ,  $V_{cc}=5.0\text{V}$ ,  $T_a=25^\circ\text{C}$ )

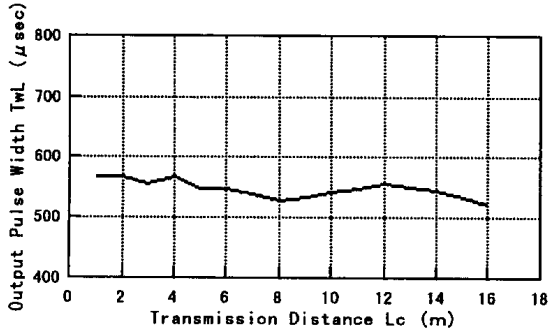

**Transmission Distance vs. Supply Voltage**  
( $T_a=25^\circ\text{C}$ )

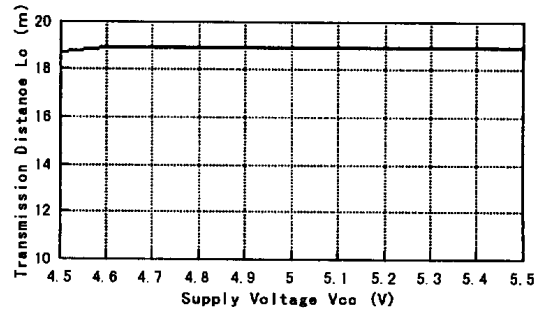

6

**Transmission Distance vs. Carrier Frequency**  
( $V_{cc}=5.0\text{V}$ ,  $T_a=25^\circ\text{C}$ )

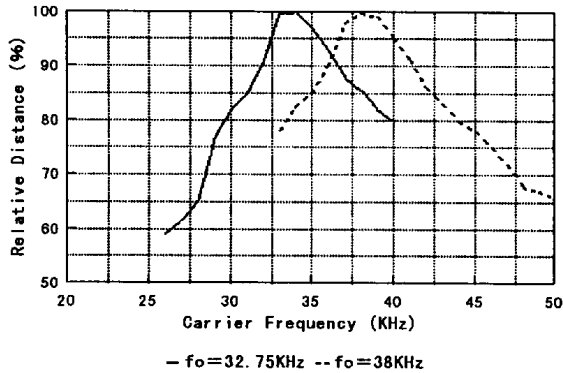

**Transmission Distance vs. Temperature**  
( $V_{cc}=5.0\text{V}$ )

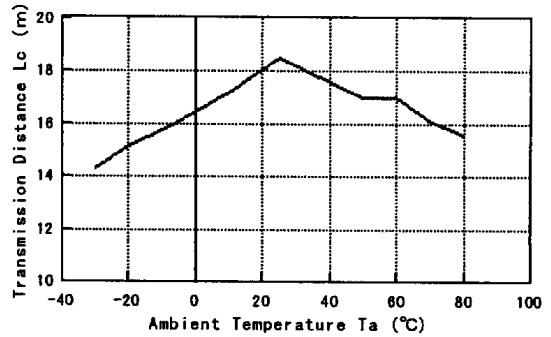



■ RECOMMENDED APPLICATION CIRCUIT

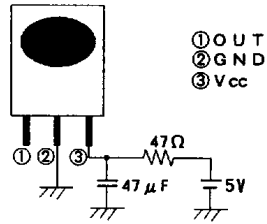

RC Filter should be connected closely between Vcc pin and GND pin.

■ OUTLINE

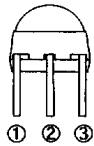
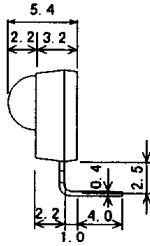
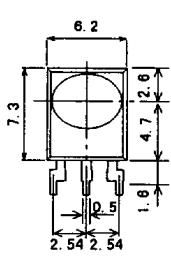

① OUT  
② GND  
③ Vcc

NJL51H000A  
UNIT : mm

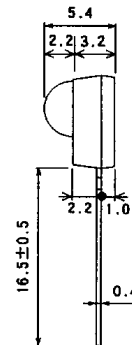
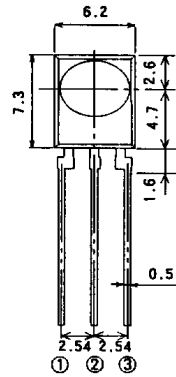

① OUT  
② GND  
③ Vcc

NJL51V000A  
UNIT : mm

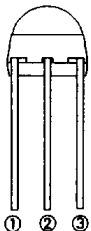
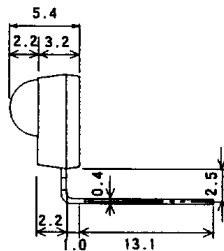
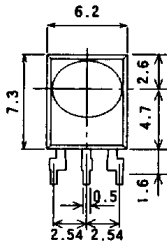

① OUT  
② GND  
③ Vcc

NJL51H000AF3  
UNIT : mm

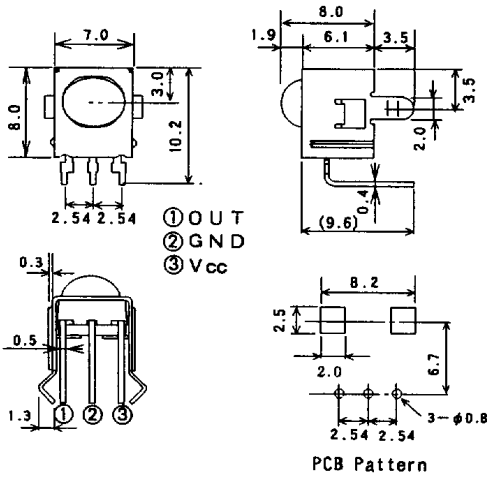

**NJL57H000A**  
UNIT : mm

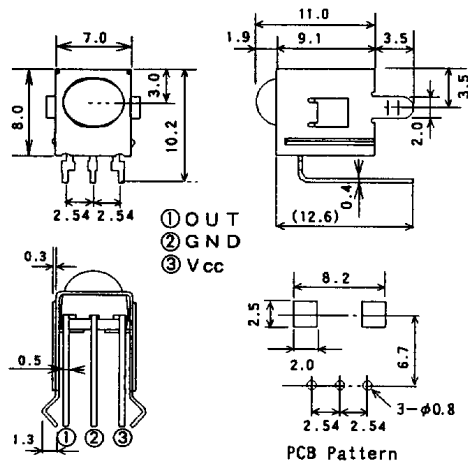

**NJL55H000A**  
UNIT : mm

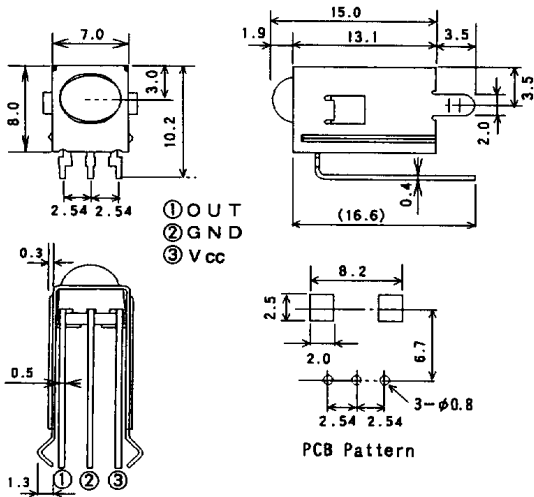

**NJL56H000A**  
UNIT : mm

1. Tolerance is  $\pm 0.3\text{mm}$  unless otherwise noted.
2. Ground metal case on PCB. Metal case is not connected to GND pin inside.

**6**