

# Servo signal processor for CD use

## BU9314KS

The BU9314KS is a servo signal processor for CD players that incorporates a double-speed, no-adjustment PLL, program servo, and signal processing block, and D/A converter on one chip. It operates off a low power supply voltage, and has low power consumption.

### ●Applications

Portable CD players, radio cassette players, and mini-component systems.

### ●Features

- 1) PLL on chip. Bit clock extraction possible with just a few external components. EFM data modulation is possible.
- 2) Frame synchronizing signal detection and protection.
- 3) Servo filters for focus, tracking, and sled are on chip. Characteristics can be controlled using commands from the controller.
- 4) Sub-code serial output pin provided.
- 5) Output pins for both P-code and Q-code.
- 6) CLV sequencer automatically determines the CLV mode.
- 7) Track jump sequencer on chip. Possible to jump any number of tracks.
- 8) De-interleave function, and 2-level error detection, correction and flag processing for C1 and C2.
- 9) The signal to the D/A converter is output by the MSB first 2'SCOMP serial out, and offset circuit ON and OFF can be controlled for CD-ROM compatibility.
- 10) 16k bits of on-chip SRAM absorb  $\pm 4$  frames of jitter.
- 11) Double-speed playback is possible.
- 12) Built-in 8Fs digital filter and 16-bit D/A converter.
- 13) Built-in digital de-emphasis function.

### ●Absolute maximum ratings (Ta = 25°C)

Parameter	Symbol	Limits	Unit
Power supply voltage	V <sub>cc</sub>	7	V
Power dissipation	P <sub>d</sub>	400*	mW
Operating temperature	T <sub>opr</sub>	-25~+70	°C
Storage temperature	T <sub>stg</sub>	-55~+125	°C

\* Reduced by 4 mW for each increase in Ta of 1°C over 25°C.

### ●Recommended operating conditions (Ta = 25°C)

Parameter	Symbol	Min.	Typ.	Max.	Unit
Power supply voltage	V <sub>cc</sub>	3.0	—	5.5	V

●Block diagram

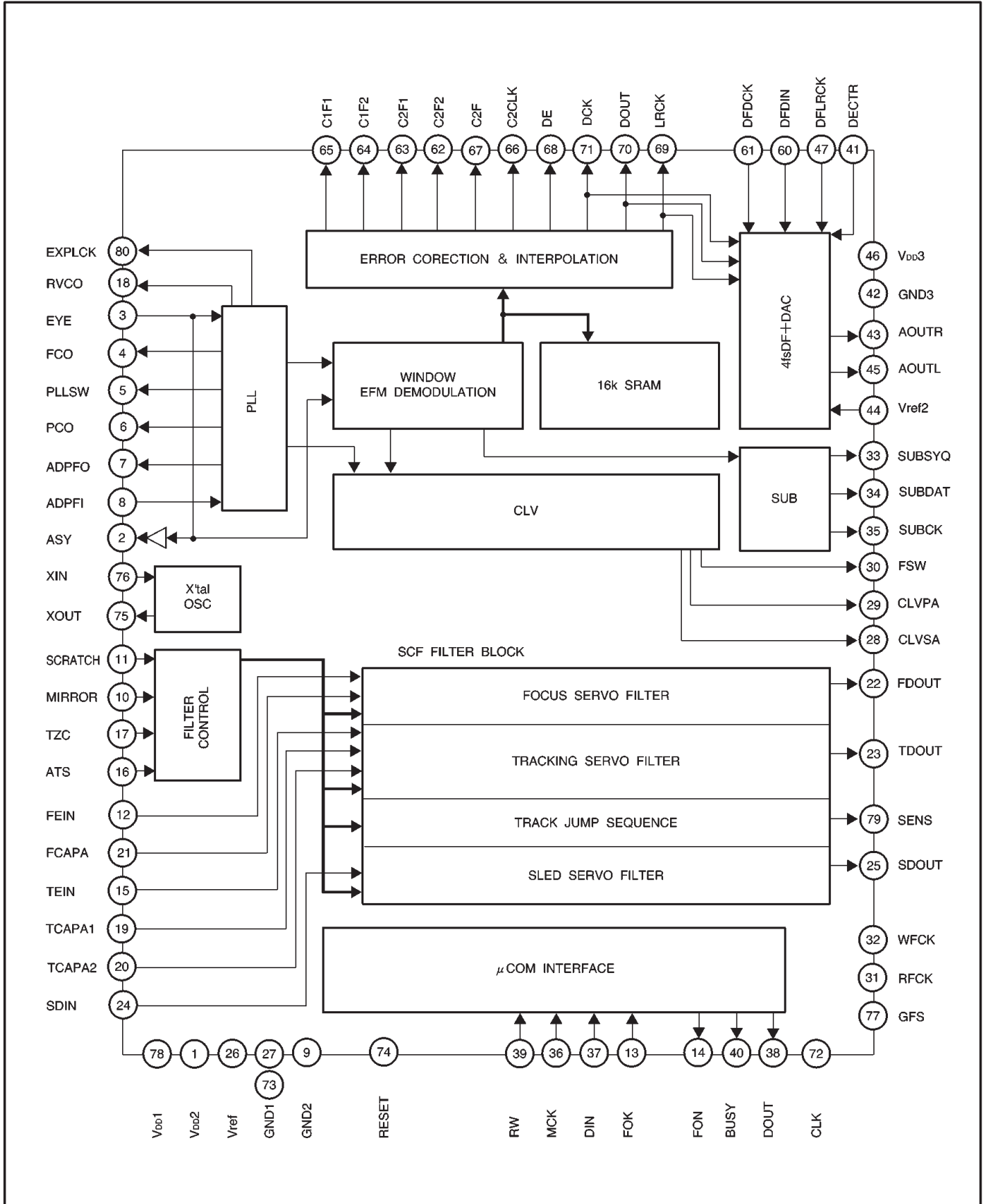



## ●Pin descriptions

Pin No.	Pin name	Analog / digital	I / O	Function	I / O circuit
1	V <sub>DD2</sub>	—	—	PLL and servo filter block power supply	—
2	ASY	Digital	O	EFM signal slice level control output	5
3	EYE	Digital	I	EFM signal input pin from the RF amplifier	4
4	FCO	Analog	O	PLL phase comparison error voltage output	7
5	PLLSW	Digital	O	PLL time constant switch pin	3
6	PCO	Analog	O	PLL phase comparison error voltage output	7
7	ADPFO	Analog	O	PLL addition amplifier output	2
8	ADPFI	Analog	I	PLL addition amplifier inversion signal	1
9	GND2	—	—	PLL servo filter block ground	—
10	MIRROR	Digital	I	Mirror signal input	4
11	SCRATCH	Digital	I	Scratch signal input	4
12	FEIN	Analog	I	Focus error signal input	1
13	FOK	Digital	I	Focus OK signal input	4
14	FON	Digital	O	Focus on signal output	5
15	TEIN	Analog	I	Tracking error signal input	1
16	ATS	Analog	I	Anti-shock detector window comparator input	1
17	TZC	Analog	I	PLL VCO free-run resistor	1
18	RVCO	Analog	O	Tracking/zero cross comparator input	1
19	TCAPA1	Analog	I / O	For connection of switch 1 for tracking servo filter	11
20	TCAPA2	Analog	I / O	For connection of switch 2 for tracking servo filter	3
21	FCAPA	Analog	I / O	For connection of capacitor for focus servo filter	11
22	FDOUT	Analog	O	Focus drive output	1
23	TDOUT	Analog	O	Tracking drive output	1
24	SDIN	Analog	I	Sled amplifier input	1
25	SDOUT	Analog	O	Sled drive output	2
26	V <sub>ref</sub>	Analog	I	Bias voltage input	6
27	GND1	—	—	Digital ground	—
28	CLVSA	Analog	O	Spindle motor drive speed control output (analog)	1
29	CLVPA	Analog	O	Spindle motor drive rough control or phase control output (analog)	1
30	FSW	Digital	O	Spindle motor output filter time constant switching output	3
31	RFCK	Digital	O	Read frame clock output (X'tal 7.35kHz)	5
32	WFCK	Digital	O	Write frame clock output (7.35kHz when locked to X'tal)	5
33	SUBSYQ	Digital	O	Sub-code sync signal S0+S1 output	5
34	SUBDATA	Digital	O	Sub-code serial output	5
35	SUBCK	Digital	I	Clock input for sub-code read	4

Pin No.	Pin name	Analog / digital	I / O	Function	I / O circuit
36	MCK	Digital	I	Clock for reading serial data from CPU or sub Q-code	4
37	DIN	Digital	I	Input for serial data from clock	4
38	DOUT	Digital	O	Sub Q-code or internal status serial output	7
39	RW	Digital	I	Read/write switch input (outputs data from DOUT when High and inputs data to DIN when Low)	4
40	BUSY	Digital	O	Busy output ( "L" during track jump)	5
41	DECTR	Digital	I	De-emphasis control (de-emphasis filter on when High)	4
42	GND3	—	—	—	—
43	AOUTL	Analog	O	Lch analog audio output	12
44	Vref2	Analog	O	Reference voltage for D/A converter (connect capacitor between this pin and GND)	6
45	AOUTR	Analog	O	Rch analog audio output	12
46	V <sub>DD3</sub>	—	—	—	—
47	DFLRCK	Digital	I	External serial data L/R switching signal input	4
48	N.C.	—	—	—	—
49	N.C.	—	—	—	—
50	N.C.	—	—	—	—
51	N.C.	—	—	—	—
52	N.C.	—	—	—	—
53	N.C.	—	—	—	—
54	N.C.	—	—	—	—
55	N.C.	—	—	—	—
56	N.C.	—	—	—	—
57	N.C.	—	—	—	—
58	N.C.	—	—	—	—
59	N.C.	—	—	—	—
60	DFDIN	Digital	I	External serial data input	4
61	DFDCK	Digital	I	Bit clock input for external serial data	4
62	C2F2	Digital	O	C22 correction flag output	5
63	C2F1	Digital	O	C21 correction flag output	5
64	C1F2	Digital	O	C12 correction flag output	5
65	C1F1	Digital	O	C11 correction flag output	5
66	C2CLK	Digital	O	Strobe signal (f=176.4kHz)	5
67	C2F	Digital	O	Correction status output	5
68	DE	Digital	O	Strobe signal (f=88.2kHz)	5
69	LRCK	Digital	O	Strobe signal (f=44.1kHz)	5

Pin No.	Pin name	Analog / digital	I / O	Function	I / O circuit
70	DOUTA	Digital	O	Audio data output (2'SCOMP)	5
71	DOCK	Digital	O	Bit clock for DOUT (f=2.1168MHz)	5
72	CLK	Digital	O	Clock output (select from four types using &hE4 command)	5
73	GND1	—	—	Digital ground	—
74	RESET	Digital	I	Internal circuit reset (pull up with internal 100kΩ resistor)	8
75	XOUT	Digital	O	X'tal oscillation circuit output (f=16.9MHz)	9
76	XIN	Digital	I	X'tal oscillation circuit input (f=16.9MHz)	9
77	GFS	Digital	O	GFS monitor output (select from four types using &hE4 command)	5
78	V <sub>DD1</sub>	—	—	Digital power supply	—
79	SENS	Digital	O	Status output of signal specified by &hE4 command)	5
80	EXPLCK	Digital	I / O	PLL playback clock output or external PLL playback clock input	10

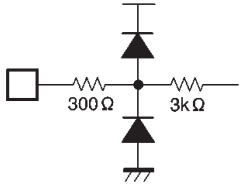
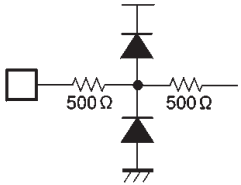
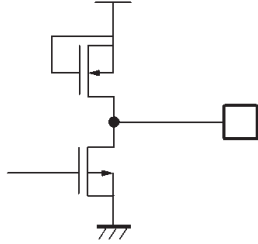
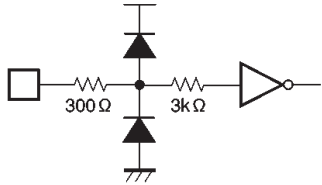
●Input / output circuits

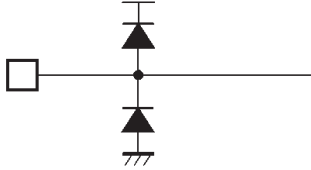
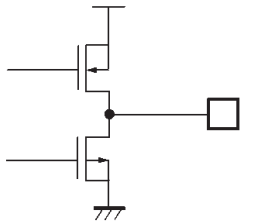
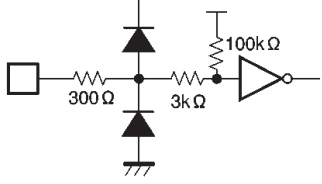
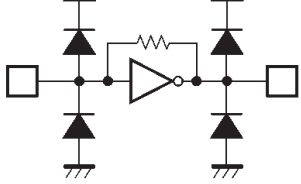
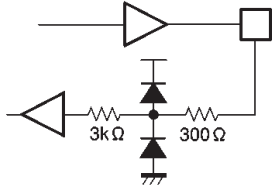
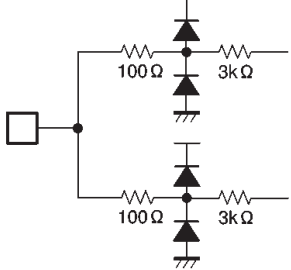
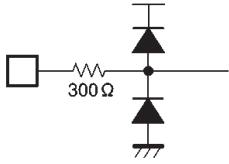
1		2	
3		4	
5		6	
7		8	
9		10	
11		12	

- \*1 MIRROR, SCRATCH, FOK, SUBCK, MCK, DIN, RW, RESET, EXPLCK, EYE, DECTR, DFLRCK, DFDIN, DFDCK
- \*2 FON, RFCK, WFCK, SUBSYQ, SUBDATA, DOUT, BUSY, XOUT, SENS, GFS, ASY, C1F1, C1F2, C2F1, C2F2, C2CLK, C2F, DE, LRCK, DOCK, CLK
- \*3 RESET
- \*4 PLLSW, TCAPA2, FSW
- \*5 FEIN, TEIN

## ●Electrical characteristics

Digital system characteristics (unless otherwise noted,  $T_a = 25^\circ\text{C}$  and  $V_{DD} = 5\text{V}$ )

Parameter	Symbol	Min.	Typ.	Max.	Unit	Conditions	Applicable pin
Input high level voltage	$V_{IH}$	3.5	—	—	V	—	*1
Input low level voltage	$V_{IL}$	—	—	0.3	V	—	*1
Output high level voltage	$V_{OH}$	4.0	—	$V_{DD}$	V	$I_{OH} = -1\text{mA}$	*2
Output low level voltage	$V_{OL}$	0	—	0.4	V	$I_{OL} = 1\text{mA}$	*2, 4
Input resistance 1	$V_{O1}$	80	100	120	$k\Omega$	Between $V_{DD1}$ pin	*3
Input resistance 2	$V_{O2}$	60	75	90	$k\Omega$	Between BIAS pin	TZC
Input resistance 3	$V_{O3}$	180	230	280	$k\Omega$	Between BIAS pin	ATS
Input resistance 4	$V_{O4}$	20	25	30	$k\Omega$	Between BIAS pin	*5
Input leak current	$I_{LI}$	—	—	$\pm 5$	$\mu\text{A}$	$V_I = 0 \sim 5.25\text{V}$	*1
Output leak current	$I_{LO}$	—	—	$\pm 5$	$\mu\text{A}$	$V_I = 0 \sim 5.25\text{V}$	*4
$V_{ref2}$ output voltage	$V_{ref2}$	—	2.5	—	V	—	$V_{ref2}$

Analog system characteristics (unless otherwise noted,  $T_a = 25^\circ\text{C}$ ,  $V_{DD} = 5\text{V}$ , and  $V_C$  reference)

Parameter	Symbol	Min.	Typ.	Max.	Unit	Conditions	Setting command
〈Focus servo〉							
DC voltage gain	$G_{FD1}$	17	20	23	dB	$V_{IN}=1\text{Hz}, 100\text{mV}_{P-P}$	&h10XF, 1462
AC voltage gain 1	$G_{FDF1}$	-0.7	2.3	5.3	dB	$V_{IN}=1\text{kHz}, 100\text{mV}_{P-P}$	&h10XF, 1462
AC voltage gain 2	$G_{FDF2}$	-5.1	-2.1	0.9	dB	$V_{IN}=300\text{Hz}, 100\text{mV}_{P-P}$	&h10XF, 1462
Maximum output voltage	$V_{FD1}$	1.5	2.1	—	V	—	—
Minimum output voltage	$V_{FD2}$	—	-2.1	-1.5	V	—	—
Offset voltage	$V_{FOF}$	-350	0	350	mV	—	&h10XF, 1462
〈Tracking servo〉							
DC voltage gain	$G_{TD1}$	23	26	29	dB	$V_{IN}=1\text{Hz}, 20\text{mV}_{P-P}$	&h10DX, 1159, 1207
AC voltage gain 1	$G_{TDF1}$	-0.5	2.5	5.5	dB	$V_{IN}=1\text{kHz}, 200\text{mV}_{P-P}$	&h10DX, 1159, 1207
AC voltage gain 2	$G_{TDF2}$	-4	-1	2	dB	$V_{IN}=300\text{Hz}, 200\text{mV}_{P-P}$	&h10DX, 1159, 1207
AC voltage gain 3	$G_{TDF3}$	28	31	34	dB	$V_{IN}=1\text{kHz}, 20\text{mV}_{P-P}$	&h10DX, 1159, 1207
AC voltage gain 4	$G_{TDF4}$	21.5	24.5	27.5	dB	$V_{IN}=300\text{Hz}, 20\text{mV}_{P-P}$	&h10DX, 1159, 1207
Maximum output voltage	$V_{TD1}$	1.5	2.1	—	V	—	—
Minimum output voltage	$V_{TD2}$	—	-2.1	-1.5	V	—	—
Offset voltage	$V_{TOF}$	-500	0	500	mV	—	&h10DX, 1159, 1287
Jump output voltage 1	$V_{JP1}$	1.2	1.8	—	V	—	&h13XF
Jump output voltage 2	$V_{JP2}$	—	-1.9	-1.1	V	—	&h13FX
ATS threshold voltage 1	$V_{ATS1}$	10	25	40	mV	—	—
ATS threshold voltage 2	$V_{ATS2}$	-40	-25	10	mV	—	—
TZC threshold voltage	$V_{TZC}$	-25	0	25	mV	—	—
〈Sled servo〉							
DC voltage gain	$G_{SD1}$	24	27	30	dB	$V_{IN}=100\text{Hz}, 20\text{mV}_{P-P}$	&h124X
Maximum output voltage	$V_{SD1}$	1.4	2	—	V	—	—
Minimum output voltage	$V_{SD2}$	—	-2.1	-1.5	V	—	—
Offset voltage	$V_{SOF}$	-220	0	220	mV	—	&h124X
Kick output voltage 1	$V_{KC1}$	1.5	2.0	—	V	—	&h18XF
Kick output voltage 2	$V_{KC2}$	—	-1.8	-1.3	V	—	&h18FX
〈Digital filter+D / A converter〉 ( $R_L=10\text{k}\Omega$ , using DIN-AUDIO filter)							
Resolution	RES	—	—	16	bit	—	—
Maximum output amplitude	$V_{MAX}$	1.7	1.9	—	V	Data pattern: 1kHz, 2V <sub>P-P</sub>	—
Distortion	THD	—	0.02	0.3	%	Data pattern: 1kHz, 2V <sub>P-P</sub>	—
Crosstalk	CT	—	-90	-70	dB	Data pattern: 1kHz, 2V <sub>P-P</sub>	—
S / N ratio	S / N	—	-90	-70	dB	—	—

©Not designed for radiation resistance.



●External dimensions (Units: mm)

