

isc Silicon NPN Power Transistor

BU941T

DESCRIPTION

- High Voltage
- DARLINGTON

APPLICATIONS

- High ruggedness electronic ignitions
- High voltage ignition coil driver

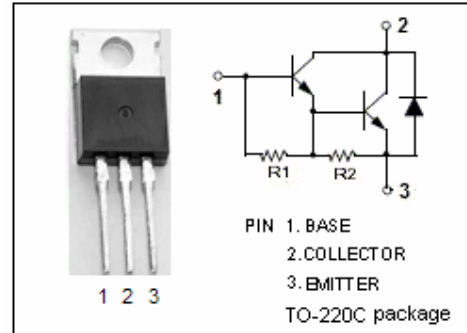

ABSOLUTE MAXIMUM RATINGS (T_a=25°C)

SYMBOL	PARAMETER	VALUE	UNIT
V _{CB0}	Collector-Base Voltage	500	V
V _{CEO}	Collector-Emitter Voltage	400	V
V _{EBO}	Emitter-Base Voltage	5	V
I _c	Collector Current- Continuous	15	A
I _{CM}	Collector Current-Peak	30	A
I _B	Base Current	1	A
I _{BM}	Base Current-Peak	5	A
P _C	Collector Power Dissipation @T _C =25°C	150	W
T _j	Junction Temperature	200	°C
T _{stg}	Storage Temperature Range	-65~200	°C

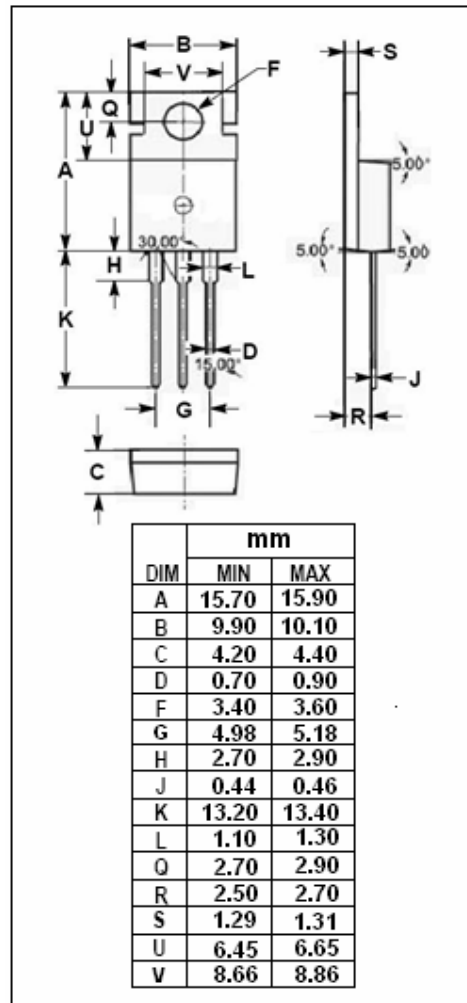

THERMAL CHARACTERISTICS

SYMBOL	PARAMETER	MAX	UNIT
R _{th j-c}	Thermal Resistance, Junction to Case	1.2	°C/W

isc Silicon NPN Power Transistor

BU941T

ELECTRICAL CHARACTERISTICS

 $T_C=25^\circ\text{C}$ unless otherwise specified

SYMBOL	PARAMETER	CONDITIONS	MIN	TYP	MAX	UNIT
$V_{CEO(SUS)}$	Collector-Emitter Sustaining Voltage	$I_C=0.1\text{A}; I_B=0; L=10\text{mH}$	400			V
$V_{CE(sat)-1}$	Collector-Emitter Saturation Voltage	$I_C=8\text{A}; I_B=100\text{mA}$			1.6	V
$V_{CE(sat)-2}$	Collector-Emitter Saturation Voltage	$I_C=10\text{A}; I_B=250\text{mA}$			1.8	V
$V_{CE(sat)-3}$	Collector-Emitter Saturation Voltage	$I_C=12\text{A}; I_B=300\text{mA}$			2.0	V
$V_{BE(sat)-1}$	Base-Emitter Saturation Voltage	$I_C=8\text{A}; I_B=100\text{mA}$			2.2	V
$V_{BE(sat)-2}$	Base-Emitter Saturation Voltage	$I_C=10\text{A}; I_B=250\text{mA}$			2.5	V
$V_{BE(sat)-3}$	Base-Emitter Saturation Voltage	$I_C=12\text{A}; I_B=300\text{mA}$			2.7	V
I_{CES}	Collector Cutoff Current	$V_{CE}=500\text{V}; V_{BE}=0$ $V_{CE}=500\text{V}; V_{BE}=0; T_j=125^\circ\text{C}$			0.1 0.5	mA
I_{CEO}	Collector Cutoff Current	$V_{CE}=450\text{V}; I_B=0$ $V_{CE}=450\text{V}; I_B=0; T_j=125^\circ\text{C}$			0.1 0.5	mA
I_{EBO}	Emitter Cutoff Current	$V_{EB}=5\text{V}; I_C=0$			20	mA
h_{FE}	DC Current Gain	$I_C=5\text{A}; V_{CE}=10\text{V}$	300			
V_{ECF}	C-E Diode Forward Voltage	$I_F=10\text{A}$			2.5	V

isc Silicon NPN Power Transistor

BU941T

$h_{FE}-I_C$ Characteristics

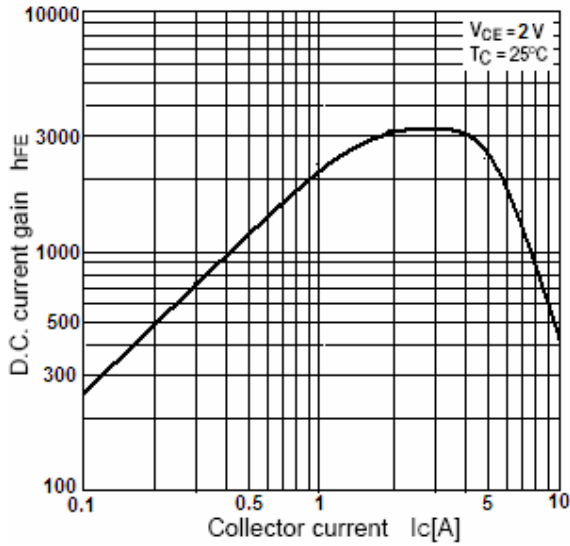

$V_{CE(sat)}-I_C$ Characteristics

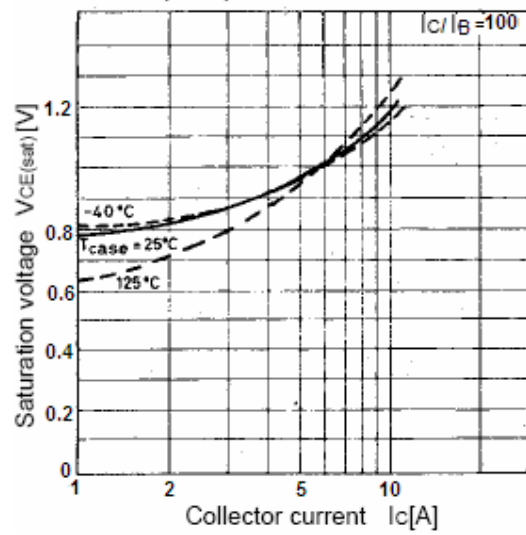

$V_{BE(sat)}-I_C$ Characteristics

