

For full details go to
www.cd4power.com/rohs

Dual Output Mixed Voltage, BCP Models

3.3V and 2.5V, "Half-Brick" 50 Watt, DC/DC Converters

Features

- Independent 3.3V and 2.5V outputs
- Up to 15 Amps per output
- Each output fully regulated
- No minimum load requirements
- 50 Watts total output power
- Standard "half-brick" package
- UL1950 and IEC/EN60950 safety approvals (BASIC insulation)
- Fully isolated, 1500Vdc guaranteed
- 18-36V or 36-75V input ranges
-  mark available (75V-input models)
- Input under and overvoltage shutdown
- Continuous short-circuit protection
- Thermal shutdown

DATEL's BCP "half-brick" series has expanded to include dual-output, 3.3V and 2.5V DC/DC converters. The BCP-3.3/15-2.5/15-D24 (18-36V input) and BCP-3.3/15-2.5/15-D48 (36-75V input) are fully isolated DC/DC converters housed in standard "half-brick" packages (2.3" x 2.4" x 0.5"). These BCP's can support any combination of 3.3V and 2.5V loading up to a combined total of 15 Amps. Both outputs are fully isolated (1500Vdc) and independently line ($\pm 0.2\%$) and load ($\pm 0.5\%$) regulated.

Both BCP models feature input pi filters, input undervoltage and overvoltage shut-down, input reverse-polarity protection, output overvoltage protection, current limiting, and thermal shutdown. Each has an on/off control function (positive and negative logic versions available), and both output voltages can be trimmed independently.

BCP Model DC/DC's deliver low noise (50mVp-p), efficiency of 84% and are fully specified for -40 to $+100^{\circ}\text{C}$ operation. Utilization of metal baseplate technology with threaded inserts permits easy heat-sink attachment and/or pcb mounting. These devices meet UL1950 and IEC/EN60950 safety standards, including BASIC insulation requirements. CB reports are available on request. "D48" models are CE marked (meet the requirements of LVD).

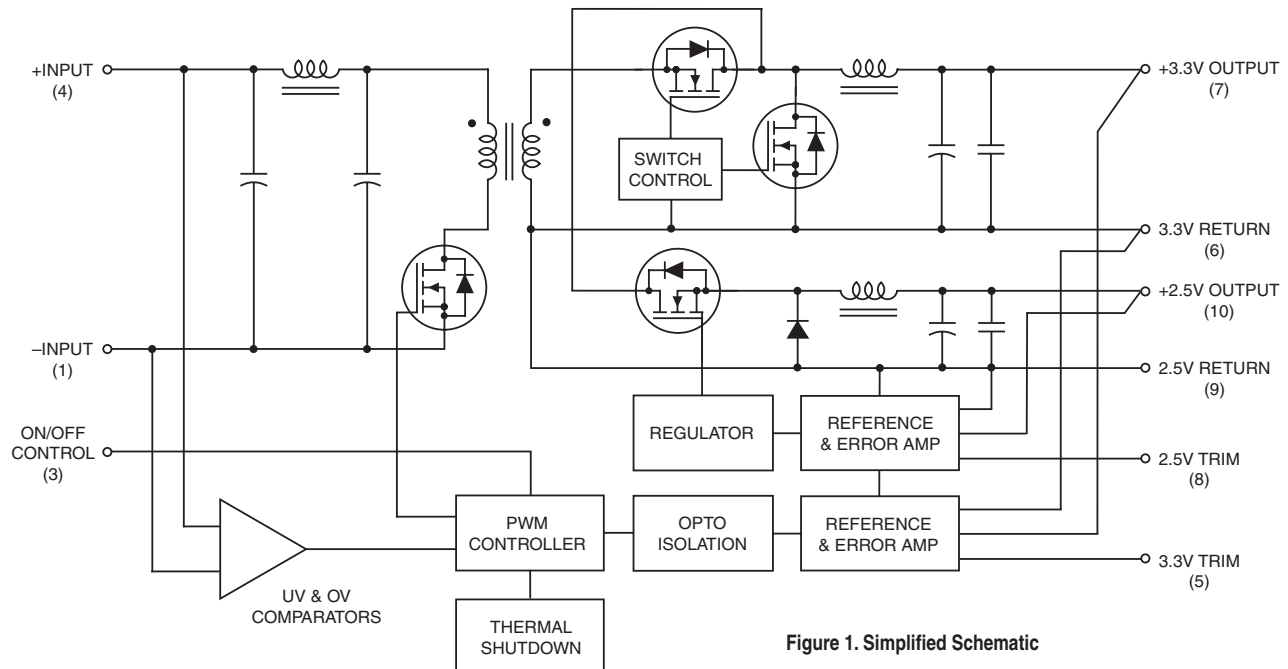

Figure 1. Simplified Schematic

Typical topology is shown

Performance Specifications and Ordering Guide ^①

Model ^⑦	Output						Input			Efficiency ^⑥		Package (Case, Pinout)
	V _{OUT} (Volts)	I _{OUT} ^⑤ (Amps)	R/N (mVp-p)		Regulation (Max.)		V _{IN} Nom. (Volts)	Range (Volts)	I _{IN} ^④ (Amps)	Min.	Typ.	
			Typ.	Max.	Line	Load ^③						
BCP-3.3/15-2.5/15-D24	3.3	15	50	100	±0.2%	±0.5%	24	18-36	0.2/2.52	82%	84%	C30, P39
	2.5	15	50	100	±0.2%	±0.5%						
BCP-3.3/15-2.5/15-D48	3.3	15	50	100	±0.2%	±0.5%	48	36-75	0.1/1.26	82%	84%	C30, P39
	2.5	15	50	100	±0.2%	±0.6%						

- ① Typical at T_A = +25°C under nominal line voltage and balanced "full-load" (3.3V @ 7.5A, 2.5V @ 7.5A) conditions unless otherwise noted.
- ② Ripple/Noise (R/N) measured over a 20MHz bandwidth. All models are specified with 22µF, low-ESR, input capacitor and 10µF tantalum in parallel with 1µF ceramic output capacitors.
- ③ No load to 100% load, other output at no-load.

- ④ Nominal line voltage, no-load/3.3V at full-load condition.
- ⑤ Current from either output at maximum value, or both outputs to a combined total of 15 A.
- ⑥ 3.3V at full-load condition.
- ⑦ These are not complete model numbers. Please refer to the Part Number Structure when ordering.

PART NUMBER STRUCTURE

BCP - 3.3 - 15 - 2.5 / 15 - D48 N LX - C

Dual Output/
Standard Half-Brick Package

RoHS Compliant

V₁ Nominal Output Voltage: 3.3 Volts

I₁ Maximum Output Current: 15A

V₂ Nominal Output Voltage: 2.5 Volts

I₂ Maximum Output Current: 15A

Input Voltage Range:

D24 = 18-36 Volts (24V nominal)

D48 = 36-75 Volts (48V nominal)

See Optional Functions

Note: Not all model number combinations are available. Contact C&D.

Optional Functions

BCP 50 Watt DC/DC's are designed with an On/Off Control function, with either positive polarity (no suffix) or negative polarity ("N"suffix), in the pin 3 position.

- Blank** On/Off Control function (positive polarity) on pin 3
- N** On/Off Control function (negative polarity) on pin 3
- L1** Pin length: 0.110 inches (2.79mm) ±0.010. Quantity order only.
- L2** Pin length: 0.145 inches (3.68mm) ±0.010. Quantity order only.
- C** RoHS-6 compliance

MECHANICAL SPECIFICATIONS

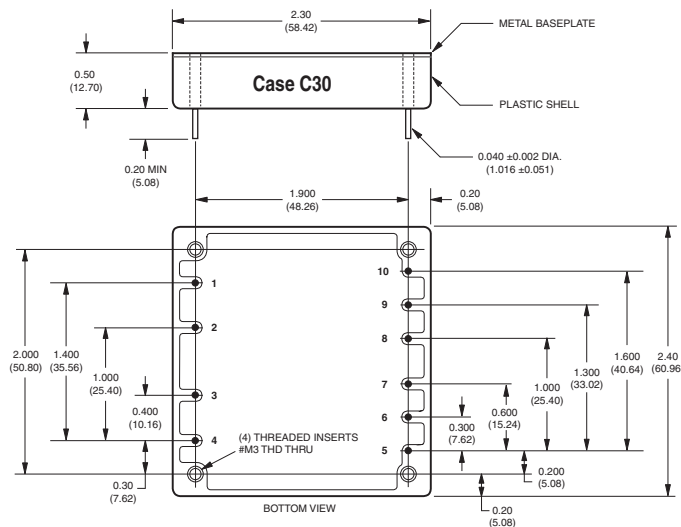

I/O Connections			
Pin	Function P39	Pin	Function P39
1	-Input	6	3.3V Return
2	Case (Baseplate)	7	+3.3V Output
3	On/Off Control	8	2.5V Trim
4	+Input	9	2.5V Return
5	3.3V Trim	10	+2.5V Output

- * Note: When mounting the heat sink to the BCP converter:
- Maximum applied torque is 6 in-lbs.
 - Minimum thread engagement of the mounting screws is 12mm deep.

Dimensions in inches(mm)

Optional Heat Sink (Part Number HS-CPLP2) *

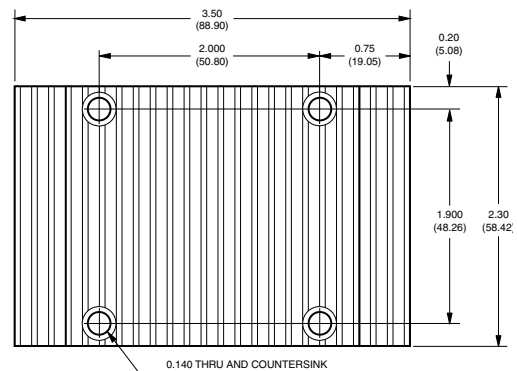

Optional Heat Sink (Part Number HS-CP) *

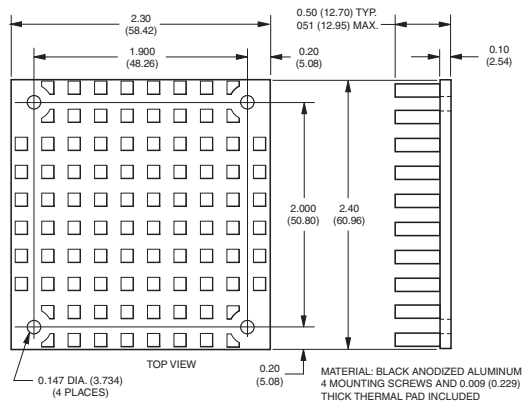

Performance/Functional Specifications

Typical @ T_A = +25°C under nominal line voltage, balanced "full-load" conditions, unless noted. ①

Input	
Input Voltage Range:	
D24 Models	18-36 Volts (24V nominal)
D48 Models	36-75 Volts (48V nominal)
Overvoltage Shutdown:	
D24 Models	40-43 Volts (41.5V typical)
D48 Models	77-80 Volts (78.5V typical)
Start-Up Threshold:	
D24 Models	16.5-18 Volts (17.5V typical)
D48 Models	33.5-36 Volts (34.5V typical)
Undervoltage Shutdown:	
D24 Models	15-17.5 Volts (16.5V typical)
D48 Models	30.5-33.5 Volts (32V typical)
Input Current:	
Normal Operating Conditions	See Ordering Guide
D24 Models	3.06 Amps maximum
D48 Models	1.53 Amps maximum
Standby Mode:	
Off, OV, UV, Thermal Shutdown	10mA typical
Input Reflected Ripple Current:	
Source Impedance <0.1Ω	
22μF Low-ESR Capacitor	88mArms, 250mAp-p maximum
Input Filter Type	Pi (0.47μF-4.7μH-3.3μF)
Reverse-Polarity Protection:	
D24 Models	1 minute duration, 6A maximum
D48 Models	1 minute duration, 3A maximum
On/Off Control: (Pin 3) ③ ⑤	
D24 & D48 Models	On = open or 13V - +V _{IN} , I _{IN} = 1mA max. Off = 0-0.8V, I _{IN} = 2mA max.
D24N & D48N Models	On = 0-0.8V, I _{IN} = 1mA max. Off = open or 2.5 - +V _{IN} , I _{IN} = 50μA max.
Output	
V_{OUT} Accuracy	
3.3V Output	±2% maximum
2.5V Output	±2% maximum
Minimum Loading per Specification	No load
Ripple/Noise (20MHz BW) ④	See Ordering Guide
Line/Load Regulation	See Ordering Guide
Efficiency	See Ordering Guide and Efficiency Curves
Trim Range ②	±5% independent
Isolation Voltage:	
Input-to-Baseplate	1500Vdc minimum
Input-to-Baseplate	1000Vdc minimum
Output-to-Case	1000Vdc minimum
Isolation Capacitance	560pF
Isolation resistance	100MΩ
Current Limit Inception:	
3.3V @ 98% V _{OUT} (2.5V @ no-load)	17-22 Amps
2.5V @ 98% V _{OUT} (3.3V @ no-load)	17-22 Amps
Short Circuit Current	Constant current 25A, indefinite
Temperature Coefficient	±0.02% per °C
Overvoltage Protection:	Comparator
3.3V Output	4.0 Volts
2.5V Output	3.25 Volts

Dynamic Characteristics	
Dynamic Load Response:	
3.3V (50-100% load step to 2% V _{OUT})	300μsec maximum
2.5V (50-100% load step to 2% V _{OUT})	300μsec maximum
Start-Up Time:	
V _{IN} to V _{OUT}	50 msec maximum
On/Off to V _{OUT}	25 msec maximum
Switching Frequency	300kHz (±50kHz)
Environmental	
MTBF	Bellcore, ground fixed, controlled
D24 Models	TBD hours (case @ TBD °C)
D48 Models	TBD hours (case @ TBD °C)
Operating Temperature (Ambient):	
θ Case to Ambient, No heatsink	TBD °C/Watt
Without Derating	-40 to +32°C (without heat sink)
With Derating	To +100°C (See Derating Curves)
Case Temperature:	
Maximum Allowable	+100°C
For Thermal Shutdown ②	+100°C minimum, +110°C maximum
Storage Temperature	-40 to +120°C
Physical	
Dimensions	2.3" x 2.4" x 0.5" (58.4 x 61 x 12.7mm)
Case (Baseplate) Connection ②	Pin 2
Case/Pin Material	Diallyl phthalate, UL94V-0 rated, aluminum baseplate; plated copper alloy pins
Weight	4.2 ounces (118 grams)
Primary to Secondary Insulation Level	Basic

① Balanced, full-load = 3.3 @ 7.5A and 2.5V @ 7.5A. Models are specified with an external 22μF, low-ESR, input capacitor and 10μF tantalum in parallel with 1μF ceramic output capacitors.

② See Technical Notes for details.

③ Devices may be ordered with negative logic (pin 3 open = off). See Part Number Structure and Technical Notes for additional information.

④ Output noise may be further reduced with the installation of additional external output capacitors. See Technical Notes.

⑤ These signals must be referenced to the input return pin (-V_{IN}).

⑥ Demonstrated MTBF available on request.

Absolute Maximum Ratings		
Input Voltage:		
Continuous:	D24 Models	43 Volts
	D48 Models	87 Volts
Transient (100msec):	D24 Models	50 Volts
	D48 Models	100 Volts
Input Reverse-Polarity Protection	Input Current must be limited. 1 minute duration. Fusing recommended.	
D24 Models	6 Amps	
D48 Models	3 Amps	
Output Overvoltage Protection ②		
3.3V Outputs	4.0 Volts, comparator	
2.5V Outputs	3.25 Volts, comparator	
Output Current ②	Current limited. Devices can withstand an indefinite output short circuit.	
Storage Temperature	-40 to +120°C	
Lead Temperature (Soldering, 10 sec.)	+300°C	

These are stress ratings. Exposure of devices to any of these conditions may adversely affect long-term reliability. Proper operation under conditions other than those listed in the Performance/Functional Specifications Table is not implied, nor recommended.

TECHNICAL NOTES

3.3V & 2.5V Outputs>Returns

The BCP Series outputs (pins 7 & 10) and returns (pins 6 & 9) are isolated from the +VIN and -VIN inputs (pins 4 & 1) via a transformer and opto-coupled transistors.

The 3.3V Return (pin 6) and 2.5V Return (pin 9) are connected internal to the DC/DC converter. Though the returns are common within the DC/DC converter, the regulating control loop for each output is sensed directly at its respective output and return pins. To maintain optimum regulation when a ground plane is not used, it is critical that PC board layouts return each output to its corresponding return pin.

Filtering and Noise Reduction

All BCP DC/DC Converters achieve their rated ripple and noise specifications using the external input and output capacitors specified in the Performance/Functional Specifications table. In critical applications, input/output noise may be further reduced by installing additional external I/O caps. Input capacitors should be selected for bulk capacitance, low ESR and high rms-ripple-current ratings. Input capacitors serve as energy-storage devices to minimize variations in line voltage caused by transient IR drops in PCB conductors from backplane to the DC/DC. Output capacitors should be selected for low ESR and appropriate frequency response. All caps should have appropriate voltage ratings and be mounted as close to the converters as possible.

The most effective combination of external I/O capacitors will be a function of your particular load and layout conditions. Our Applications Engineers can recommend potential solutions and can discuss the possibility of our modifying a device's internal filtering to meet your specific requirements. Contact our Applications Engineering Group for additional details.

Input Fusing

Certain applications and/or safety agencies may require the installation of fuses at the inputs of power conversion components. Fuses should also be used if the possibility of sustained, non-current-limited, input-voltage polarity reversals exists. For DATEL BCP DC/DC Converters, you should use slow-blow type fuses with values no greater than the following.

V _{IN} Range	Fuse Value
"D24" Models	6 Amps
"D48" Models	3 Amps

Fuses should be installed in the +Input line.

Input Overvoltage/Undervoltage Shutdown and Start-Up Threshold

Under normal start-up conditions, devices will not begin to regulate until the ramping-up input voltage exceeds the Start-Up Threshold Voltage (35V for "D48" models). Once operating, devices will not turn off until the input voltage drops below the Undervoltage Shutdown limit (32V for "D48" models). Subsequent re-start will not occur until the input is brought back up to the Start-Up Threshold. This built-in hysteresis prevents any unstable on/off situations from occurring at a single voltage.

Input voltages exceeding the input overvoltage shutdown specification listed in the Performance/Functional Specifications will cause the device to shut-down. A built-in hysteresis (2V typical for "D24" models, 4V typical for "D48" models) will not allow the converter to restart until the input voltage is sufficiently reduced.

Start-Up Time

The V_{IN} to V_{OUT} start-up time is the interval between the time at which a ramping input voltage crosses the turn-on threshold point and the fully-loaded output voltage enters and remains within its specified accuracy band. Actual measured times will vary with input source impedance, external input capacitance, and the slew rate and final value of the input voltage as it appears to the converter.

The On/Off to V_{OUT} start-up time assumes the converter has its nominal input voltage applied but is turned off via the On/Off Control. The specification defines the interval between the time at which the converter is turned on and the fully loaded output voltage enters and remains within its specified accuracy band.

On/Off Control (Standard feature)

The On/Off Control (pin 3) may be used for remote on/off operation. As shown in Figure 1A, the control pin is referenced to the -Input (pin 1). The standard BCP converter (no suffix) is designed so that it is enabled when the control pin is left open and disabled when the control pin is pulled low (to less than +0.8V relative to -Input).

Dynamic control of the on/off function is best accomplished with a mechanical relay or an open-collector/open-drain drive circuit (optically isolated if appropriate). The drive circuit should be able to sink approximately 1mA for logic low.

The on/off control function is designed such that the converter can be disabled (pin 3 pulled low for no-suffix models) while input power is ramping up and then "released" once the input has stabilized.

For BCP converters configured with a negative-polarity option ("N" suffix added to part number), operation is opposite to that described above. The converter is disabled when the On/Off Control pin is left open and enabled when pulled low.

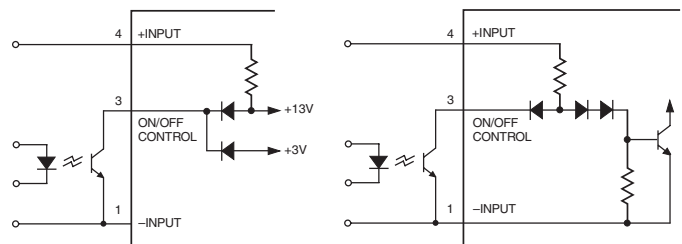

Figure 1A. No Suffix

Figure 1B. "N" Suffix

Output Overvoltage Protection

Each voltage output of the BCP Series converter is independently monitored via an output comparator. If the output voltage should rise to a level which could be damaging to the load circuitry (see Performance/Functional Specifications for limits), the overvoltage circuitry will power down the PWM controller causing the output voltages to collapse. Following a time out period the converter will restart. If the fault condition persists the PWM will again power down and the cycle will repeat. This on/off cycling is referred to as a "hiccup-mode."

Case Connection

BCP DC/DC's do not connect the metal baseplate to an internal voltage. The "uncommitted" baseplate is connected to pin 2 which, depending upon your system configuration, should be connected to either +Input (pin 4), -Input (pin 1), Output Return (pins 6 & 9), or earth ground.

Thermal Shutdown

The BCP Series is equipped with Thermal Shutdown circuitry. If environmental conditions cause the internal temperature of the DC/DC converter to rise above the designed operating temperature (see Performance/Functional Specifications), a precision temperature sensor will power down the unit. When the internal temperature decreases below the threshold of the temperature sensor the unit will self-start.

Input Reverse-Polarity Protection

Upon applying a reverse-polarity voltage to the DC/DC converter, an internal diode will be forward biased and draw excessive current from the power source. Therefore, it is required that the input current be limited by either an appropriately rated input fuse or a current limited power source.

Threaded Inserts and Heatsink Installation

CAUTION: Do not use the threaded inserts to bolt the converter down to a PC board. That will place unnecessary force on the mounting pins. Instead, the converter is held securely by only soldering the mounting pins.

When attaching the heat sink from above the converter, use a maximum torque of 2 inch-pounds (0.23 N-m) on the M3 bolts to avoid damaging the threaded inserts. Use a tiny amount of fastener adhesive or M3 lockwashers to secure the bolts.

Heat Sinks for BCP Series

DATEL offers two standard heat sinks that can be mounted to the half-brick package to extend the converter's operating temperature range. Along with the standard 2.3" x 2.4" x 0.5" (HS-CP) heat sink, DATEL has designed a low-profile heat sink for height-restricted applications. This new heat sink (HS-CPLP2) is designed with radiant fins that extend 0.51" beyond either side of the 2.4" dimension of the BCP package. The convenience of this design is that the finned extensions protrude only 0.31" below the top surface of the DC/DC converter, allowing components with a profile height less than 0.2" to be mounted on the pc board below the heat sink. Therefore, while the surface area of the low-profile heat sink measures 2.3" x 3.5", pcb real estate is unaffected.

For optimum thermal performance in a natural convection application, the low-profile heat sink should be mounted with the fins vertically oriented. Both models are shipped with 0.009" self-adhesive thermal pad and mounting screws.

Note: When mounting the heat sink to the BCP converter:

1. Maximum applied torque is 2 in-lbs.
2. Minimum thread engagement of the mounting screws is 12mm deep.

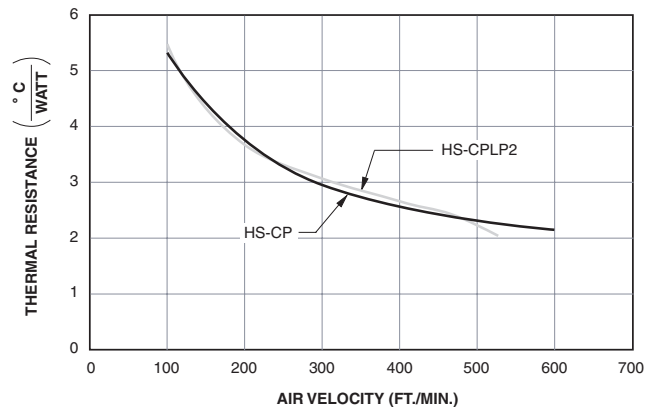

Figure 2. HS-CP and HS-CPLP2 Heat Sink Performance Vs. Air Flow

Output Trimming

Both the 3.3V and 2.5V outputs of the BCP Series can be independently trimmed via a trimpot (Figure 3A) or a single fixed resistor as shown (Figures 3B & 3C). The trimpot can be used to determine the value of a single fixed resistor. A single fixed resistor can increase or decrease the output voltage depending on its connection. Fixed resistors should have absolute TCR's less than 100ppm/°C to ensure stability.

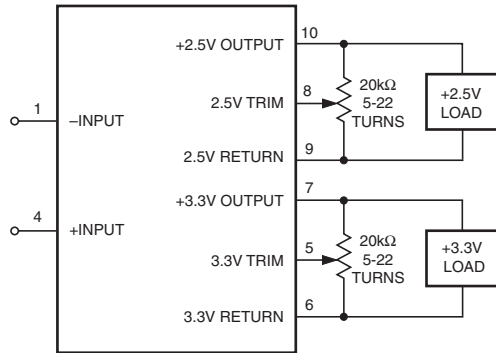

Figure 3A. Trim Connections Using a Trimpot

A resistor connected from the Trim Pin (pin 5 for 3.3V trim, pin 8 for 2.5V trim) to the appropriate Return (pin 6 for 3.3V trim, pin 9 for 2.5V trim) will increase the output voltage.

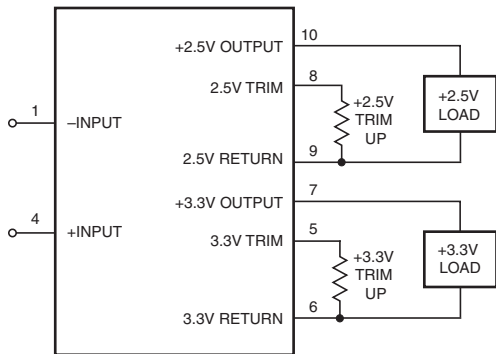

Figure 3B. Increase Output Voltage Trim Connections Using a Fixed Resistor

A single resistor connected from the Trim Pin (pin 5 for 3.3V trim, pin 8 for 2.5V trim) to its appropriate +Output (pin 7 for 3.3V trim, pin 10 for 2.5V trim) will decrease the output voltage.

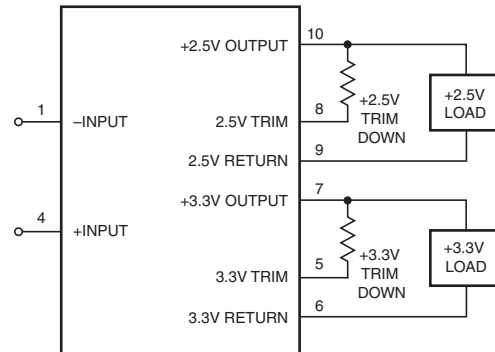

Figure 3C. Decrease Output Voltage Trim Connections Using a Fixed Resistor