

X-band RX-TX Core Chip
GaAs Monolithic Microwave IC

Preliminary

Description

The CHC3014 is a Receive and Transmit X band Core Chip.

It includes a 6 bit phase shifter, a 6 bit attenuator, a second 2 bit attenuator for tuning, self-biased buffers, switch and TTL compatible parallel interfaces.

This device is manufactured 0.25 μm pHEMT process, including via holes through the substrate.

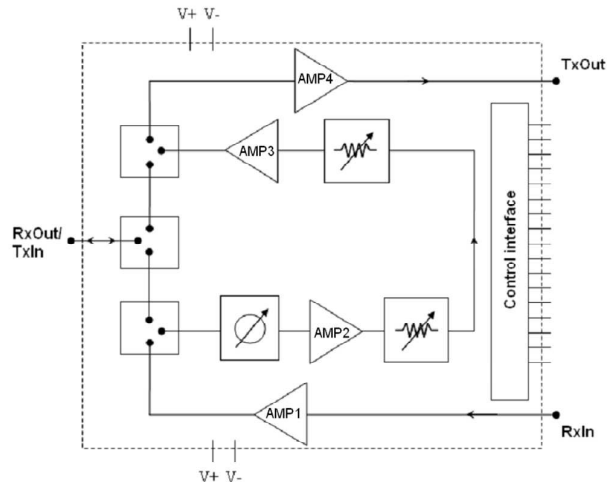

Main Features

- Operating frequency range: 8 -12 GHz
- Receive path linear gain: 13.5 dB
- Transmit path linear gain: 25 dB
- Phase shift range: 0-360° (step 5.625°)
- Fine attenuator: 34.65dB (step 0.55dB)
- Tuning attenuator: 6dB (step 2dB)
- Chip size: 4.47 x 5.07 x 0.1mm

Main Characteristics

V+ = 5V / V- = -5V

Symbol	Parameter	Min	Typ	Max	Unit
Freq	Frequency range	8		12	GHz
Rms_pe	RMS phase error		2		°
Rms_att	RMS attenuation error		0.3		dB
P1dB _{RX}	Output power at RXOUT @1dB gain compression		16.5		dBm
Psat _{TX}	Output power at TXOUT at saturation		20		dBm
NF	Noise figure in RX mode		5.8		dB

ESD Protection: Electrostatic discharge sensitive device. Observe handling precautions!

Electrical Characteristics

T= +25°C

Preliminary

Symbol	Parameters	Min	Typ	Max	Unit
Freq	Operating frequency	8		12	GHz
	Mode RX				
G_{RX}	Linear gain in Rx mode at reference state (1)		13.5		dB
$S_{11_{RX}}$	Input Return Loss in Rx mode		-14		dB
$S_{22_{RX}}$	Output Return Loss in Rx mode		-18		dB
NF	Noise figure in Rx mode (2)		5.8		dB
$P_{1dB_{RX}}$	Output power at RXOUT at 1dB gain compression		16.5		dBm
	Mode TX				
G_{TX}	Linear gain in Tx mode at reference state (1)		25		dB
$S_{11_{TX}}$	Input Return Loss in Tx mode		-14		dB
$S_{22_{TX}}$	Output Return Loss in Tx mode		-12		dB
$P_{IN_{TX}}$	Input power range in Tx saturated mode	0		15	dBm
$P_{sat_{TX}}$	Output power at TXOUT in saturated mode		20		dBm
	Isolated Mode (3)				
$S_{11_{ISOLATED}}$	Return Loss at RXin/TXout		-15		dB
	6 bit Phase shifter (4)		0-360		°
	Phase shift elementary step		5.625		°
PPE	Peak phase error (Rx, Tx, fine attenuator state < 33 tuning attenuator state 1) 8 GHz-8.5GHz 8.5 GHz-11.5 GHz 11.5 GHz-12 GHz		4 ± 6 0 ± 6 4 ± 6		°
Rms_pe	RMS phase error (Rx, Tx, fine attenuator state < 33 tuning attenuator state 1) 8 GHz-8.5 GHz 8.5 GHz-11.5 GHz 11.5 GHz-12 GHz		2.5 2 2.5		°
Ampvar	Amplitude variation (Rx, Tx, fine attenuator state < 33 tuning attenuator state 1)		0 ± 1		dB
Rms_Ampvar	RMS Amplitude variation (Rx, Tx, fine attenuator state < 33 tuning attenuator state 1)		0.3		dB

Preliminary

Symbol	Parameters	Min	Typ	Max	Unit
	6 bit Fine Attenuator (4)		34.65		dB
	Fine Attenuator elementary step		0.55		dB
Att_err _{att}	Attenuation error (Rx, all phase shifter states tuning attenuator state 1) <i>Attenuation state 0-32</i> <i>Attenuation state 33-47</i> <i>Attenuation state 48-63</i>		0 ± 0.5 -0.25 ± 0.75 -0.5 ± 1.5		dB
Rms_att	RMS attenuation error (Rx, all phase shifter states tuning attenuator state 1)		0.3		dB
Phivar _{att}	Phase variation (Rx, all phase shifter states tuning attenuator state 1) <i>Attenuation state 0-32</i> <i>Attenuation state 33-47</i> <i>Attenuation state 48-63</i>		0 ± 3 -1 ± 5 -4 ± 6		°
Rms_Phivar	RMS Phase variation (Rx, all phase shifter states tuning attenuator state 1)		2		°
	2 bit Tuning Attenuator (5)		6		dB
	Tuning Attenuator elementary step		2		dB
Att_Err _{TB}	Tuning attenuation error		± 0.3		dB
Phivar _{TB}	Phase variation of tuning attenuator		± 2		°
	Biasing (6)				
V+	Positive supply voltage		5		V
V-	Negative supply voltage		-5		V
	Control voltage low level	0	0	+0.4	V
	Control voltage high level	+2.4	+3.3	+5	V
I _{+5_Rx}	Biasing current in RX mode		335		mA
I _{+5_Tx}	Biasing current in TX mode		350 (7) 470 (8)		mA
I _{+5_interface}	Control interface DC current		25		mA
I ₋₅	Negative DC current		-50		mA

- (1) Reference state: Tuning attenuator state = 1 / Fine attenuator state = 0 / Phase shifter state = 0
- (2) Noise Figure value for Tuning attenuator state = 0 / Fine attenuator state = 0 / Phase shifter state = 0
- (3) In this mode, the MFC presents a matched load on the RF access pad RXin/TXout
- (4) Low influence of cross-talking between phase shifter and fine attenuator
- (5) This function allows to adjust roughly the linear gain
- (6) Each Amplifiers of Rx and Tx paths can be switched off thanks to separate biasing pads (c.f. pad allocation table)
- (7) Tx linear mode
- (8) Tx saturated mode

Preliminary

Absolute Maximum Ratings (1)

T= +25°C

Symbol	Parameter	Values	Unit
V+	Maximum positive bias voltage	6	V
V-	Negative voltage range	-6 to -4	V
P_RFRX	Maximum peak input power overdrive in Rx mode	16	dBm
P_RFTX	Maximum peak input power overdrive in Tx mode	16	dBm
Tch	Maximum channel temperature (2)	175	°C
Ta	Operating temperature range	-40 to +85	°C
Tstg	Storage temperature range	-55 to +125	°C

- (1) Operation of this device above anyone of these paramaters may cause permanent damage.
 (2) Thermal Resistance channel to ground paddle = 164°C/W for T= +85°C

Typical Measurements

T= +25°C

[S] parameters in RX mode

Preliminary

S21 vs. Frequency
Tuning attenuator states 0-1-2-3
Fine attenuator state 0, Phase shifter state 0

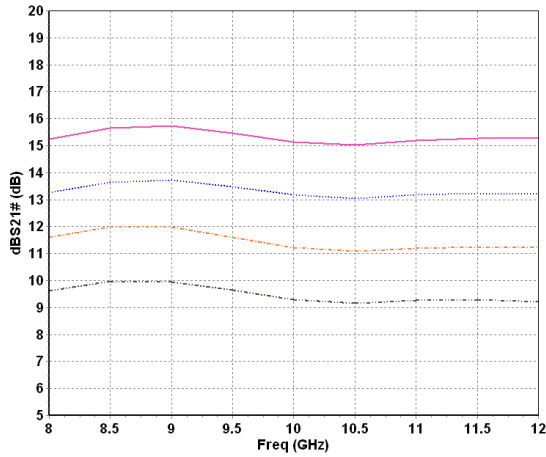

Noise Factor vs. Frequency
Tuning attenuator states 0-1-2-3
Fine attenuator state 0, Phase shifter state 0

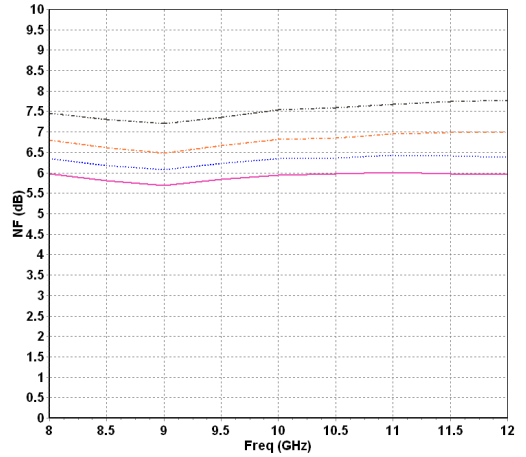

S11 vs. Frequency
Tuning attenuator states 0-1-2-3
Fine attenuator states 0-1-2-4-8-16-32-63
Phase shifter states 0-1-2-4-8-16-32-63

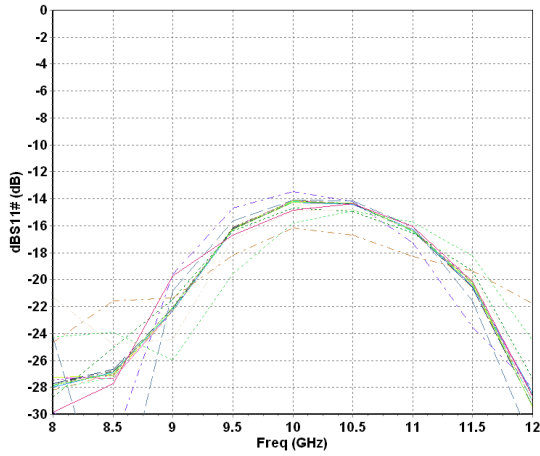

S22 vs. Frequency
Tuning attenuator states 0-1-2-3
Fine attenuator states 0-1-2-4-8-16-32-63
Phase shifter states 0-1-2-4-8-16-32-63

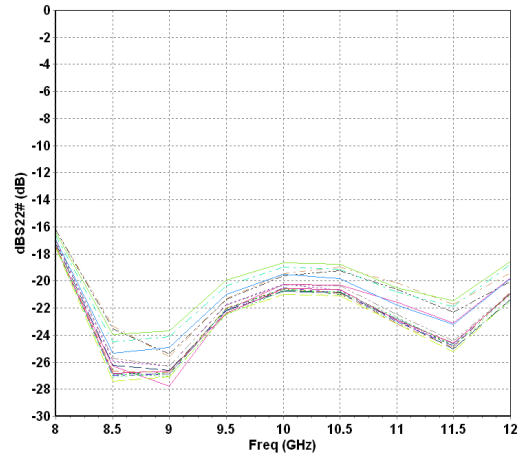

Preliminary

[S] parameters in TX mode

S21 vs. Frequency
 Tuning attenuator state 1
 Fine attenuator state 0, Phase shifter state 0

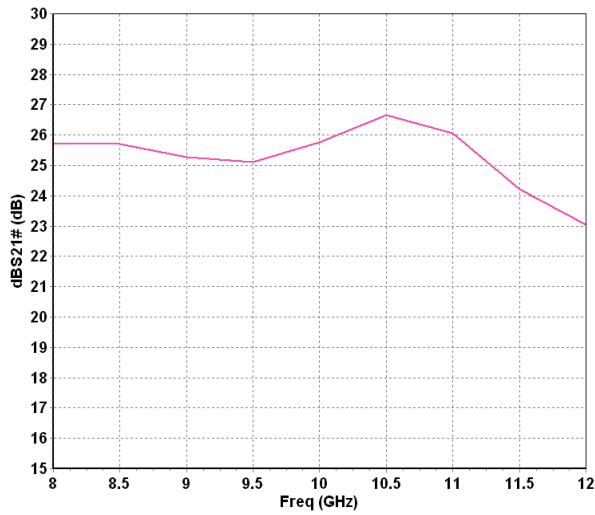

S11 vs. Frequency
 Tuning attenuator state 1, Fine attenuator state 0
 Phase shifter states 0-1-2-4-8-16-32-63

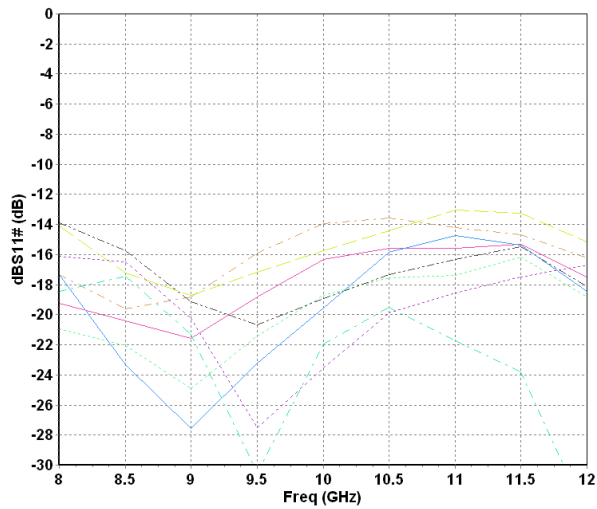

S22 vs. Frequency
 Tuning attenuator state 1, Fine attenuator state 0
 Phase shifter states 0-1-2-4-8-16-32-63

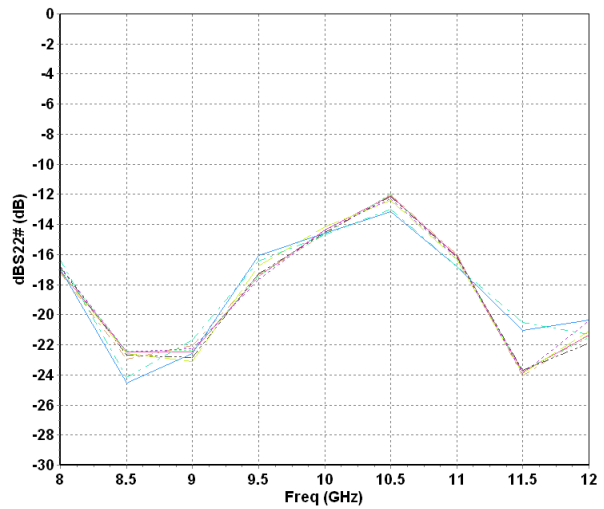

Preliminary

Phase shifter performances: Phase error

Phase error vs. frequency in RX and TX mode
Tuning attenuator state 1
Fine attenuator states 0-8-16-32

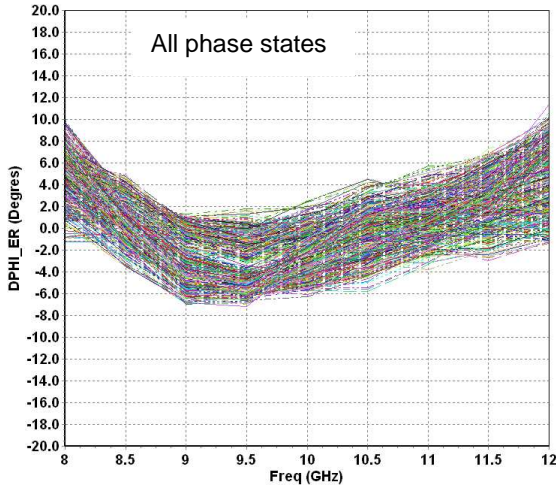

Phase error vs. phase state in RX and TX mode
for attenuation states 0, 8, 16, 32

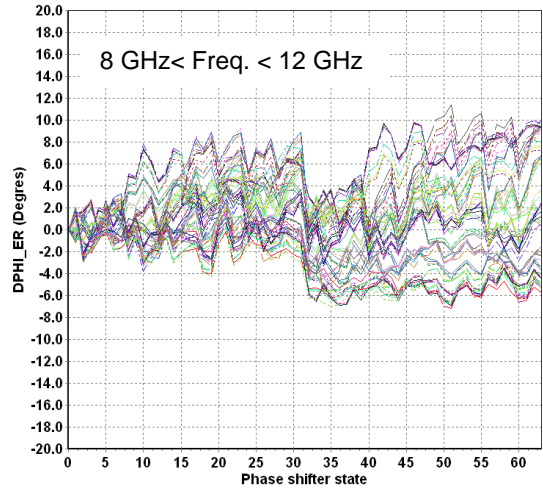

RMS of phase error in RX and TX mode

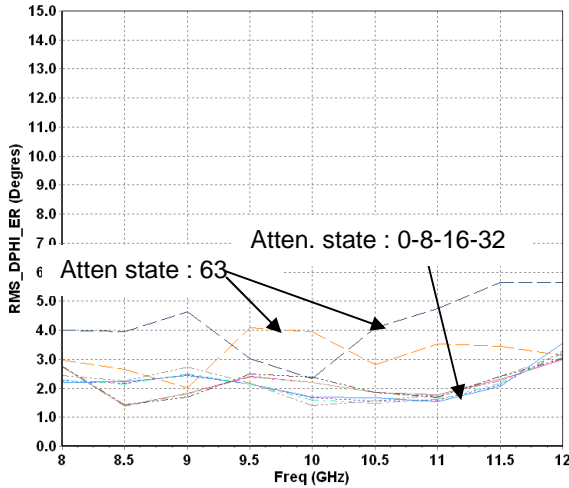

Phase shift vs. phase shifter state in RX and TX mode
Tuning attenuator state 1
Fine attenuator states 0-8-16-32

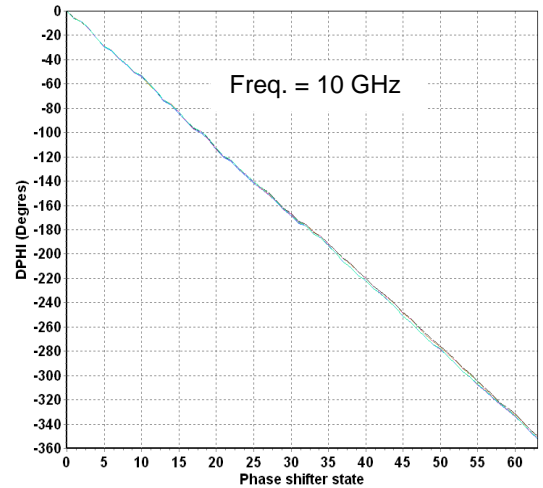

Preliminary

Phase shifter performances: Amplitude variation

Amplitude variation vs. frequency in RX and TX mode
Tuning attenuator state 1
Fine attenuator states 0-8-16-32

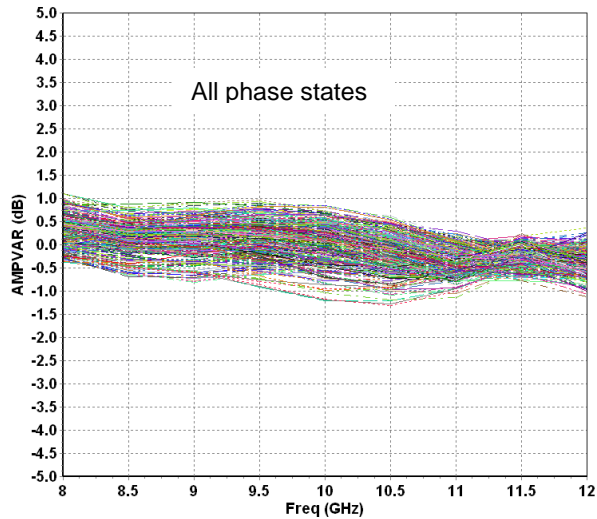

Amplitude variation vs. phase state in RX and TX mode
Tuning attenuator state 1
Fine attenuator states 0-8-16-32

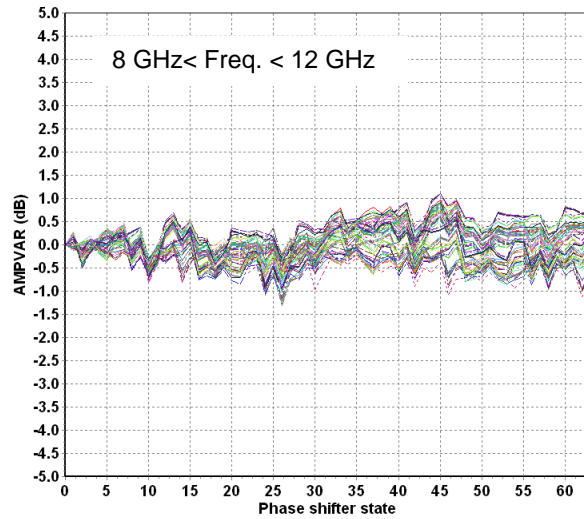

RMS amplitude variation in RX and TX mode
Tuning attenuator state 1
Fine attenuator states 0-8-16-32

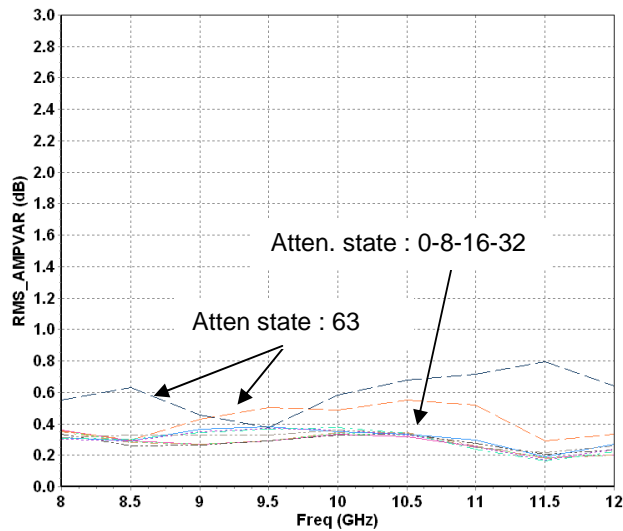

Fine Attenuator performances: Error of attenuation *Preliminary*

Attenuation error vs. freq. in RX mode
Tuning attenuator state 1
Phase shifter states 0-8-16-32-63

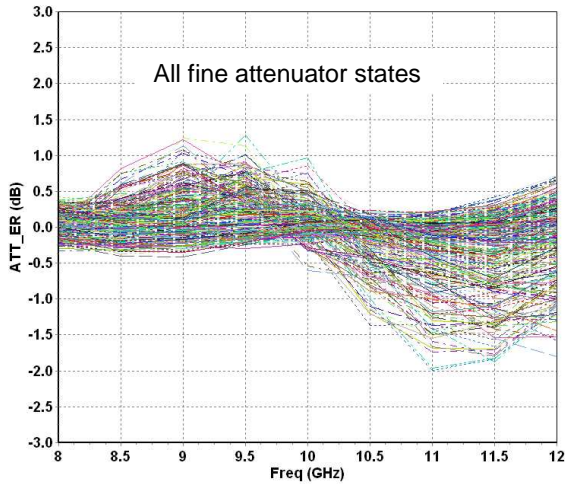

Attenuation error vs. atten. state in RX mode
Tuning attenuator state 1
Phase shifter states 0-8-16-32-63

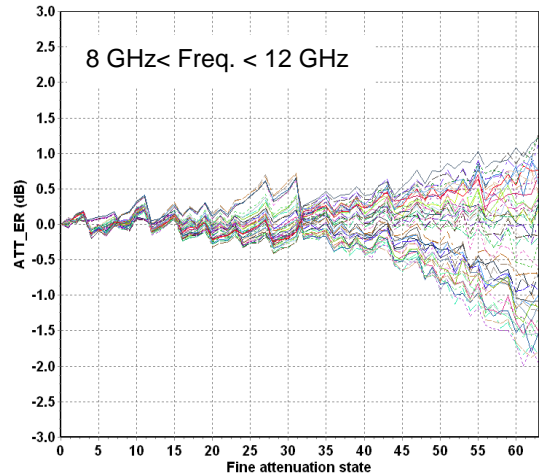

RMS attenuation error in RX mode
Tuning attenuator state 1
Phase shifter states 0-8-16-32-63

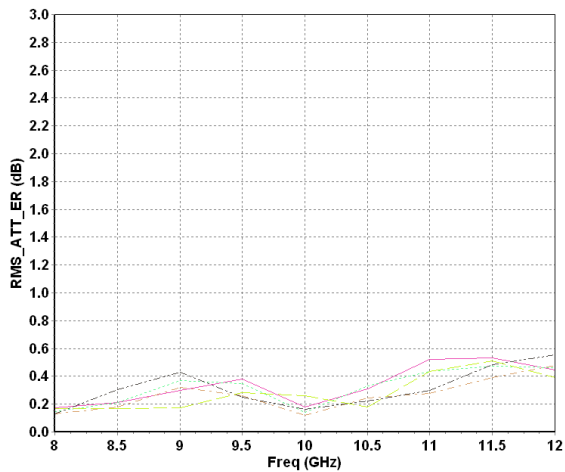

Attenuation vs. Fine attenuator state in RX mode
Tuning attenuator state 1
Phase shifter states 0-8-16-32-63

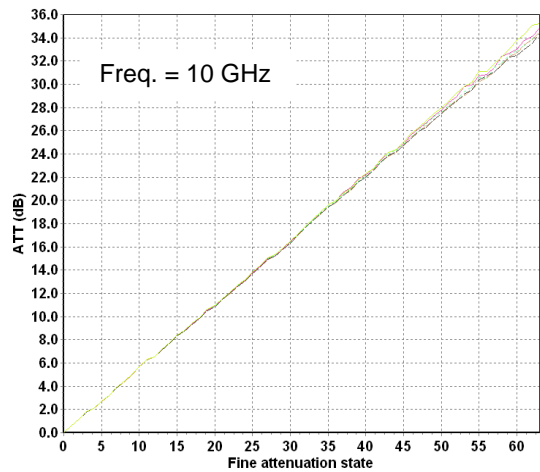

Preliminary

Fine Attenuator performances: phase variation

Phase variation vs. freq. in RX mode
Tuning attenuator state 1
Phase shifter states 0-8-16-32-63

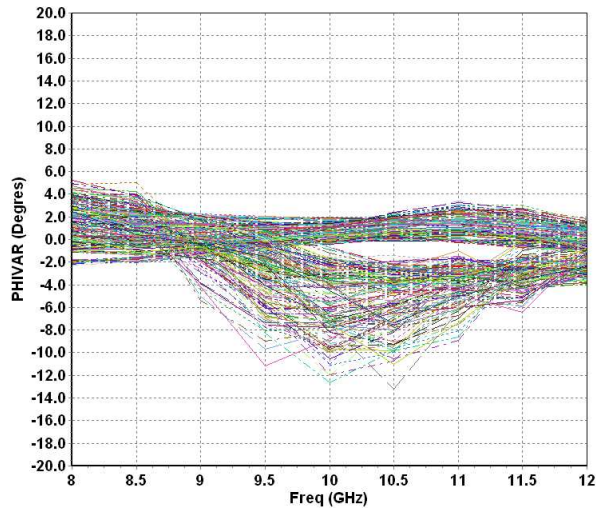

Phase variation vs. atten. state in RX mode
Tuning attenuator state 1
Phase shifter states 0-8-16-32-63

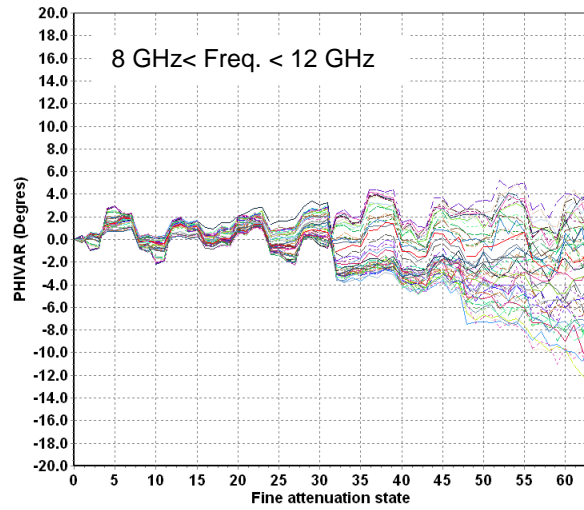

RMS phase variation in RX mode
Tuning attenuator state 1
Phase shifter states 0-8-16-32-63

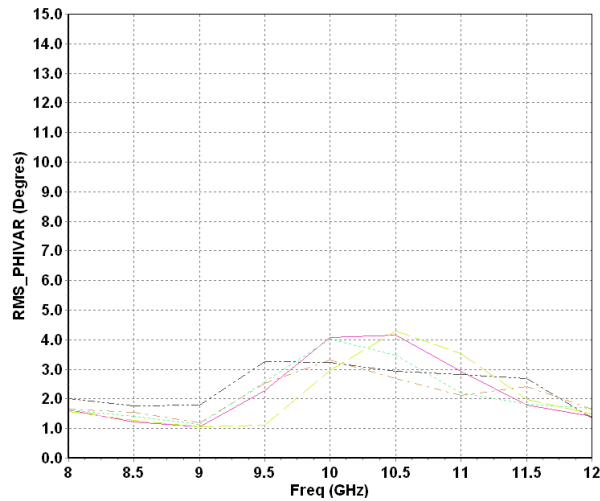

Preliminary

Tuning Attenuator performances

Tuning attenuation error vs. freq.
RX mode
Fine attenuator state 0, Phase shifter state 0

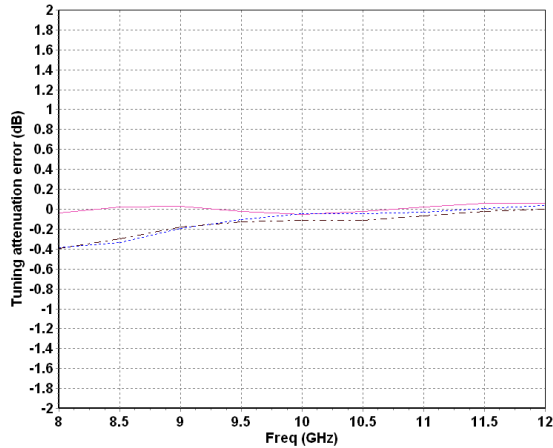

Phase variation of tuning attenuator vs. freq
RX mode
Fine attenuator state 0, Phase shifter state 0

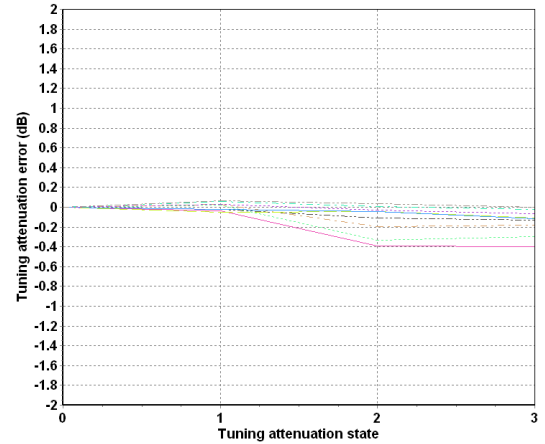

Tuning attenuation vs. tuning atten. state at 10 GHz
RX mode
Fine attenuator state 0, Phase shifter state 0

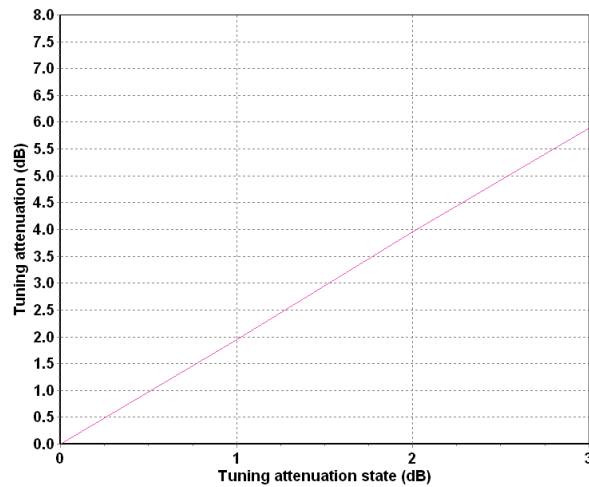

MMIC mechanical dimensions and pad allocation

Preliminary

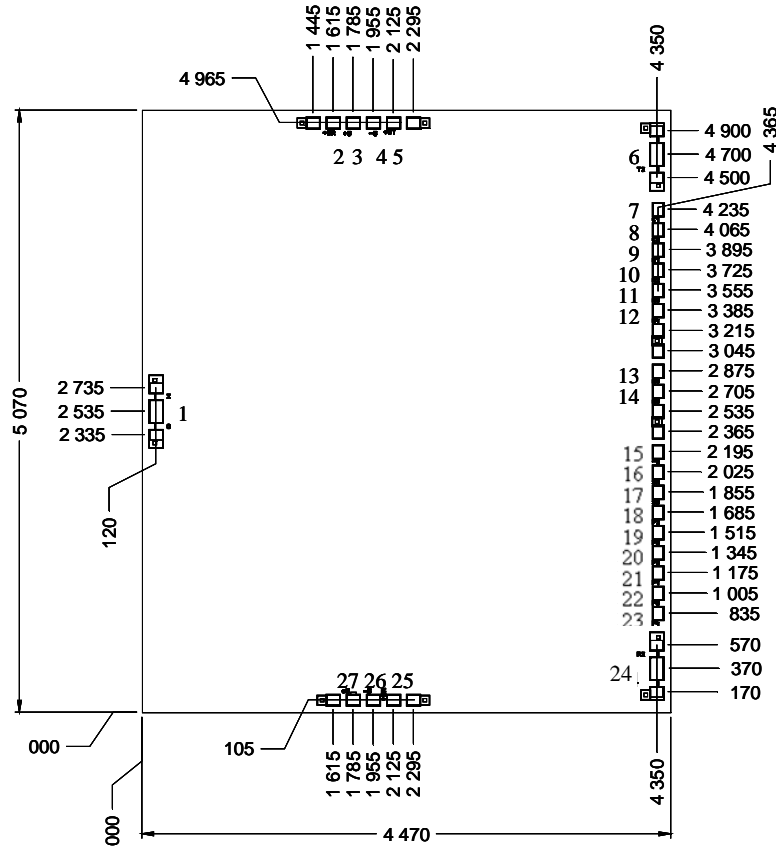

UNITS : μm
Tol : $\pm 35\mu\text{m}$

Chip thickness = $100\mu\text{m} \pm 10\mu\text{m}$.

RF pads (1, 6, 24) = $122 \times 200\mu\text{m}^2$

DC and control pads (2, 3, 4, 5, 7 to 23, 25, 26, 27) = $120 \times 100\mu\text{m}^2$

Pin number	Pad name	Description
1	IO	Input/Output RF: Rxout. Txin
2	+5R	+5V supply voltage Amplifier 3
3	+5	+5V supply voltage : interface
4	-5	-5V supply voltage
5	+5T	+5V supply voltage Amplifier 4
6	TX	Output RF: TXout
7	C1	Coarse attenuator bit 1
8	C2	Coarse attenuator bit 2
9	A1	Attenuator bit 1
10	A2	Attenuator bit 2
11	A3	Attenuator bit 3
12	A4	Attenuator bit 4
13	A5	Attenuator bit 5
14	A6	Attenuator bit 6

Pin number	Pad name	Description
15	-5	-5V supply voltage: interface
16	SA	Switch bit 1
17	SB	Switch bit 2
18	P1	Phase shifter bit 1
19	P2	Phase shifter bit 2
20	P3	Phase shifter bit 3
21	P4	Phase shifter bit 4
22	P5	Phase shifter bit 5
23	P6	Phase shifter bit 6
24	RX	Input RF: RXin
25	+5R	+5V supply voltage Amplifier 1
26	-5	-5V supply voltage
27	+5	+5V supply voltage Amplifier 2

Bonding length recommendations

Preliminary

Port	Connection
TXin/RXout (1) TXout (6) RXin (24)	Inductance (L _{bonding}) = 0.3nH two wires: diameter 25 μm, length 0.470μm
DC and Interface pads	Inductance (L _{bonding}) = 0.8nH one wire: diameter 25 μm, length 1mm

Recommended assembly diagram

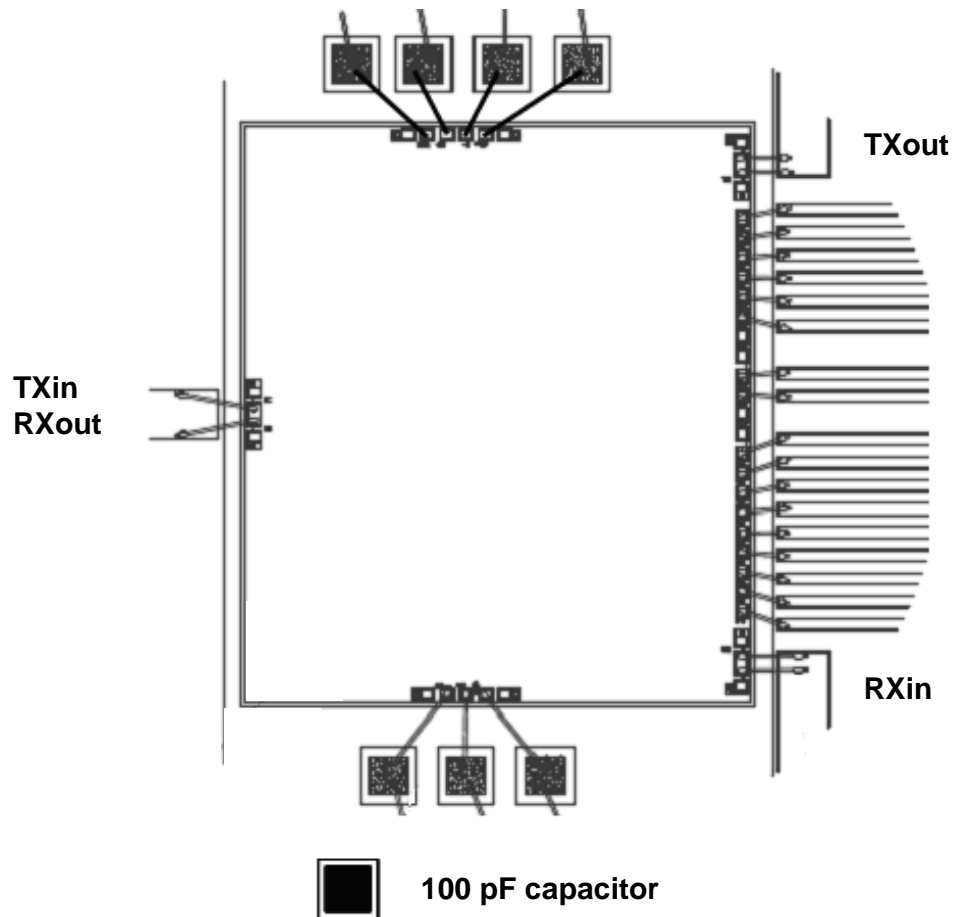

Assembly diagram

Note: Biasing pads 2-5-25-27 can be commonly connected to the +5V supply voltage

Preliminary

OPERATING MODE

BIASING CONDITIONS

General Biasing conditions

Pin number	Pad name	Value	Pin number	Pad name	Value
2	+5R	+5V	15	-5	-5V
3	+5	+5V	16	SA	0 or 3.3V
4	-5	-5V	17	SB	0 or 3.3V
5	+5T	+5V	18	P1	0 or 3.3V
7	C1	0 or 3.3V	19	P2	0 or 3.3V
8	C2	0 or 3.3V	20	P3	0 or 3.3V
9	A1	0 or 3.3V	21	P4	0 or 3.3V
10	A2	0 or 3.3V	22	P5	0 or 3.3V
11	A3	0 or 3.3V	23	P6	0 or 3.3V
12	A4	0 or 3.3V	25	+5R	+5V
13	A5	0 or 3.3V	26	-5	-5V
14	A6	0 or 3.3V	27	+5	+5V

General biasing conditions

SWITCHES CONTROL TABLE

Voltages to apply on the pads SA SB:

	SA	SB
Adaptative Isolation mode	3.3	3.3
RX path	3.3	0
TX path	0	3.3
Not used	0	0

Switch control table

Note: When the MFC is used in adaptative isolation mode, it presents a matched load to the RF access pad RXin/TXout

TUNING ATTENUATOR CONTROL TABLE

Voltages to apply on the pads C1 C2:

state	Att (dB)	C2	C1
0	0	0	0
1	2	0	3.3
2	4	3.3	0
3	6	3.3	3.3

Coarse bit control table

*Preliminary***ATTENUATOR CONTROL TABLE**

Voltage to apply on the pads A1 to A6:

state	Att (dB)	A6	A5	A4	A3	A2	A1
0	0	0	0	0	0	0	0
1	0.55	0	0	0	0	0	3.3
2	1.1	0	0	0	0	3.3	0
3	1.65	0	0	0	0	3.3	3.3
4	2.2	0	0	0	3.3	0	0
5	2.75	0	0	0	3.3	0	3.3
6	3.3	0	0	0	3.3	3.3	0
7	3.85	0	0	0	3.3	3.3	3.3
8	4.4	0	0	3.3	0	0	0
9	4.95	0	0	3.3	0	0	3.3
10	5.5	0	0	3.3	0	3.3	0
11	6.05	0	0	3.3	0	3.3	3.3
12	6.6	0	0	3.3	3.3	0	0
13	7.15	0	0	3.3	3.3	0	3.3
14	7.7	0	0	3.3	3.3	3.3	0
15	8.25	0	0	3.3	3.3	3.3	3.3
16	8.8	0	3.3	0	0	0	0
17	9.35	0	3.3	0	0	0	3.3
18	9.9	0	3.3	0	0	3.3	0
19	10.45	0	3.3	0	0	3.3	3.3
20	11	0	3.3	0	3.3	0	0
21	11.55	0	3.3	0	3.3	0	3.3
22	12.1	0	3.3	0	3.3	3.3	0
23	12.65	0	3.3	0	3.3	3.3	3.3
24	13.2	0	3.3	3.3	0	0	0
25	13.75	0	3.3	3.3	0	0	3.3
26	14.3	0	3.3	3.3	0	3.3	0
27	14.85	0	3.3	3.3	0	3.3	3.3
28	15.4	0	3.3	3.3	3.3	0	0
29	15.95	0	3.3	3.3	3.3	0	3.3
30	16.5	0	3.3	3.3	3.3	3.3	0
31	17.05	0	3.3	3.3	3.3	3.3	3.3
32	17.6	3.3	0	0	0	0	0

33	18.15	3.3	0	0	0	0	3.3
34	18.7	3.3	0	0	0	3.3	0
35	19.25	3.3	0	0	0	3.3	3.3
36	19.8	3.3	0	0	3.3	0	0
37	20.35	3.3	0	0	3.3	0	3.3
38	20.9	3.3	0	0	3.3	3.3	0
39	21.45	3.3	0	0	3.3	3.3	3.3
40	22	3.3	0	3.3	0	0	0
41	22.55	3.3	0	3.3	0	0	3.3
42	23.1	3.3	0	3.3	0	3.3	0
43	23.65	3.3	0	3.3	0	3.3	3.3
44	24.2	3.3	0	3.3	3.3	0	0
45	24.75	3.3	0	3.3	3.3	0	3.3
46	25.3	3.3	0	3.3	3.3	3.3	0
47	25.85	3.3	0	3.3	3.3	3.3	3.3
48	26.4	3.3	3.3	0	0	0	0
49	26.95	3.3	3.3	0	0	0	3.3
50	27.5	3.3	3.3	0	0	3.3	0
51	28.05	3.3	3.3	0	0	3.3	3.3
52	28.6	3.3	3.3	0	3.3	0	0
53	29.15	3.3	3.3	0	3.3	0	3.3
54	29.7	3.3	3.3	0	3.3	3.3	0
55	30.25	3.3	3.3	0	3.3	3.3	3.3
56	30.8	3.3	3.3	3.3	0	0	0
57	31.35	3.3	3.3	3.3	0	0	3.3
58	31.9	3.3	3.3	3.3	0	3.3	0
59	32.45	3.3	3.3	3.3	0	3.3	3.3
60	33	3.3	3.3	3.3	3.3	0	0
61	33.55	3.3	3.3	3.3	3.3	0	3.3
62	34.1	3.3	3.3	3.3	3.3	3.3	0
63	34.65	3.3	3.3	3.3	3.3	3.3	3.3

Fine attenuator control table

Preliminary

PHASE SHIFTER CONTROL TABLE

Voltage to apply on the pads P1 to P6:

state	Phase (deg)	P6	P5	P4	P3	P2	P1
0	0	0	0	0	0	0	0
1	-5.625	0	0	0	0	0	3.3
2	-11.25	0	0	0	0	3.3	0
3	-16.875	0	0	0	0	3.3	3.3
4	-22.5	0	0	0	3.3	0	0
5	-28.125	0	0	0	3.3	0	3.3
6	-33.75	0	0	0	3.3	3.3	0
7	-39.375	0	0	0	3.3	3.3	3.3
8	-45	0	0	3.3	0	0	0
9	-50.625	0	0	3.3	0	0	3.3
10	-56.25	0	0	3.3	0	3.3	0
11	-61.875	0	0	3.3	0	3.3	3.3
12	-67.5	0	0	3.3	3.3	0	0
13	-73.125	0	0	3.3	3.3	0	3.3
14	-78.75	0	0	3.3	3.3	3.3	0
15	-84.375	0	0	3.3	3.3	3.3	3.3
16	-90	0	3.3	0	0	0	0
17	-95.625	0	3.3	0	0	0	3.3
18	-101.25	0	3.3	0	0	3.3	0
19	-106.875	0	3.3	0	0	3.3	3.3
20	-112.5	0	3.3	0	3.3	0	0
21	-118.125	0	3.3	0	3.3	0	3.3
22	-123.75	0	3.3	0	3.3	3.3	0
23	-129.375	0	3.3	0	3.3	3.3	3.3
24	-135	0	3.3	3.3	0	0	0
25	-140.625	0	3.3	3.3	0	0	3.3
26	-146.25	0	3.3	3.3	0	3.3	0
27	-151.875	0	3.3	3.3	0	3.3	3.3
28	-157.5	0	3.3	3.3	3.3	0	0
29	-163.125	0	3.3	3.3	3.3	0	3.3
30	-168.75	0	3.3	3.3	3.3	3.3	0
31	-174.375	0	3.3	3.3	3.3	3.3	3.3
32	-180	3.3	0	0	0	0	0

33	-185.625	3.3	0	0	0	0	3.3
34	-191.25	3.3	0	0	0	3.3	0
35	-196.875	3.3	0	0	0	3.3	3.3
36	-202.5	3.3	0	0	3.3	0	0
37	-208.125	3.3	0	0	3.3	0	3.3
38	-213.75	3.3	0	0	3.3	3.3	0
39	-219.375	3.3	0	0	3.3	3.3	3.3
40	-225	3.3	0	3.3	0	0	0
41	-230.625	3.3	0	3.3	0	0	3.3
42	-236.25	3.3	0	3.3	0	3.3	0
43	-241.875	3.3	0	3.3	0	3.3	3.3
44	-247.5	3.3	0	3.3	3.3	0	0
45	-253.125	3.3	0	3.3	3.3	0	3.3
46	-258.75	3.3	0	3.3	3.3	3.3	0
47	-264.375	3.3	0	3.3	3.3	3.3	3.3
48	-270	3.3	3.3	0	0	0	0
49	-275.625	3.3	3.3	0	0	0	3.3
50	-281.25	3.3	3.3	0	0	3.3	0
51	-286.875	3.3	3.3	0	0	3.3	3.3
52	-292.5	3.3	3.3	0	3.3	0	0
53	-298.125	3.3	3.3	0	3.3	0	3.3
54	-303.75	3.3	3.3	0	3.3	3.3	0
55	-309.375	3.3	3.3	0	3.3	3.3	3.3
56	-315	3.3	3.3	3.3	0	0	0
57	-320.625	3.3	3.3	3.3	0	0	3.3
58	-326.25	3.3	3.3	3.3	0	3.3	0
59	-331.875	3.3	3.3	3.3	0	3.3	3.3
60	-337.5	3.3	3.3	3.3	3.3	0	0
61	-343.125	3.3	3.3	3.3	3.3	0	3.3
62	-348.75	3.3	3.3	3.3	3.3	3.3	0
63	-354.375	3.3	3.3	3.3	3.3	3.3	3.3

Phase shifter control table

Ordering Information

Chip form : CHC3014-99F/00

Information furnished is believed to be accurate and reliable. However **United Monolithic Semiconductors S.A.S.** assumes no responsibility for the consequences of use of such information nor for any infringement of patents or other rights of third parties which may result from its use. No license is granted by implication or otherwise under any patent or patent rights of **United Monolithic Semiconductors S.A.S.**. Specifications mentioned in this publication are subject to change without notice. This publication supersedes and replaces all information previously supplied. **United Monolithic Semiconductors S.A.S.** products are not authorised for use as critical components in life support devices or systems without express written approval from **United Monolithic Semiconductors S.A.S.**