

FEATURES

- Wide Input Voltage Range: 3.5V to 30V
- Low Quiescent Current: 7mA
- Internal 8A Switch (10A for LT1270A)
- Very Few External Parts Required
- Self-Protected Against Overloads
- Shutdown Mode Draws Only 100 μ A Supply Current
- Flyback-Regulated Mode Has Fully Floating Outputs
- Comes in Standard 5-Pin Package
- Can be Externally Synchronized
(See LT1072 Data Sheet)

APPLICATIONS

- High Efficiency Buck Converter
- PC Power Supply with Multiple Outputs
- Battery Upconverter
- Negative-to-Positive Converter

USER NOTE:

This data sheet is only intended to provide specifications, graphs and a general functional description of the LT1270A/LT1270. Application circuits are included to show the capability of the LT1270A/LT1270. A complete design manual (AN-19) should be obtained to assist in developing new designs. AN-19 contains a comprehensive discussion of both the LT1070 and the external components used with it, as well as complete formulas for calculating the values of these components. AN-19 can also be used for the LT1270A/LT1270 by factoring in the higher switch current rating and higher operating frequency.

A comprehensive CAD program called SwitcherCad is also available. Contact the local sales office in your area or the factory direct.

DESCRIPTION

The LT1270A/LT1270 are monolithic high power switching regulators. Identical to the popular LT1070, except for switching frequency (60kHz) and higher switch current, they can be operated in all standard switching configurations including buck, boost, flyback, and inverting. A high current, high efficiency switch is included on the die along with all oscillator, control, and protection circuitry. Integration of all functions allows the LT1270A/LT1270 to be built in a standard TO-220 power package. This makes it extremely easy to use and provides "bust proof" operation similar to that obtained with 3-pin linear regulators.

The LT1270A/LT1270 operate with supply voltages from 3.5V to 30V, and draw only 7mA quiescent current. By utilizing current-mode switching techniques, they provide excellent AC and DC load and line regulation.

The LT1270A/LT1270 use adaptive anti-sat switch drive to allow very wide ranging load currents with no loss in efficiency. An externally activated shutdown mode reduces total supply current to 100 μ A typical for standby operation.

TYPICAL APPLICATION

High Efficiency[†] Buck Converter

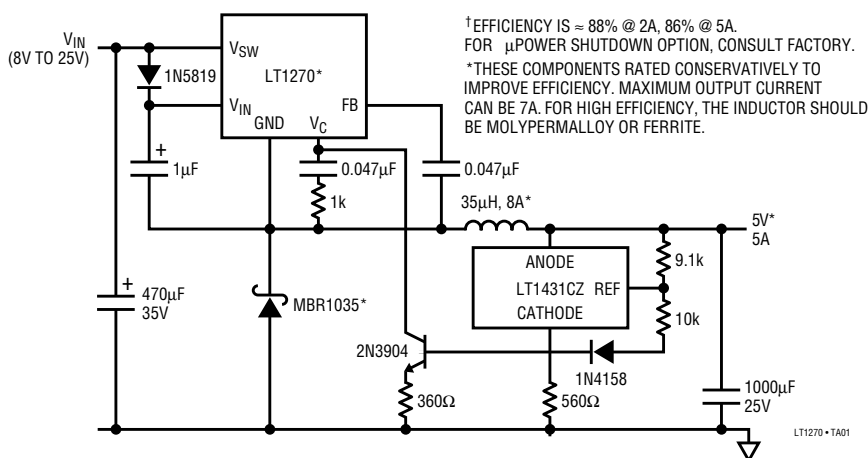

Maximum Output Power*

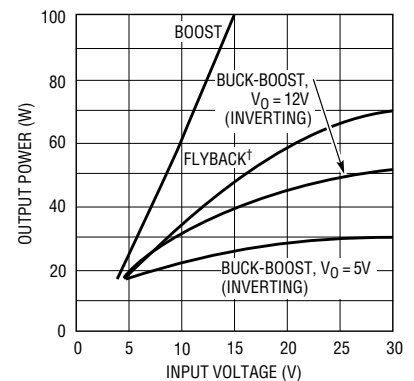

*MULTIPLY BY 1.2 FOR LT1270A.
 BUCK MODE OUTPUT POWER \approx (7.5A)(V_{OUT})
[†] TRANSFORMER TURNS RATIO MUST BE OPTIMUM TO ACHIEVE FULL POWER

ABSOLUTE MAXIMUM RATINGS

Supply Voltage	30V
Switch Output Voltage	60V
Feedback Pin Voltage (Transient, 1ms)	±15V
Operating Junction Temperature Range	
LT1270AC/LT1270C (Oper.)	0°C to 125°C
LT1270AC/LT1270C (Short-Ckt)	0°C to 140°C
Storage Temperature Range	-65°C to 150°C
Lead Temperature (Soldering, 10 sec)	300°C

PACKAGE/ORDER INFORMATION

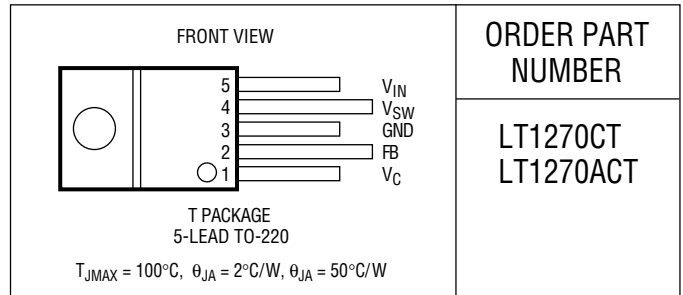

ELECTRICAL CHARACTERISTICS

$V_{IN} = 15\text{V}$, $V_C = 0.5\text{V}$, $V_{FB} = V_{REF}$, switch pin open, unless otherwise noted.

SYMBOL	PARAMETER	CONDITIONS	MIN	TYP	MAX	UNITS	
V_{REF}	Reference Voltage	Measured at Feedback Pin $V_C = 0.8\text{V}$	●	1.224	1.244	1.264	V
				1.214	1.244	1.274	V
I_B	Feedback Input Current	$V_{FB} = V_{REF}$		350	750	1100	nA
							nA
gm	Error Amplifier Transconductance	$\Delta I_C = \pm 25\mu\text{A}$	●	3000	4400	6000	μmho
				2400		7000	μmho
	Error Amplifier Source of Sink Current	$V_C = 1.5\text{V}$	●	150	200	350	μA
			120		400	μA	
	Error Amplifier Clamp Voltage	Hi Clamp, $V_{FB} = 1\text{V}$ Lo Clamp, $V_{FB} = 1.5\text{V}$		1.80	2.30		V
			0.25	0.38	0.52	V	
	Reference Voltage Line Regulation	$3\text{V} \leq V_{IN} \leq V_{MAX}$, $V_C = 0.8\text{V}$	●		0.03	%/V	
A_V	Error Amplifier Voltage Gain	$0.9\text{V} \leq V_C \leq 1.4\text{V}$		500	800		V/V
	Minimum Input Voltage		●	2.8	3.0	V	
I_Q	Supply Current	$3\text{V} \leq V_{IN} \leq V_{MAX}$, $V_C = 0.6\text{V}$		7	10		mA
	Control Pin Threshold	Duty Cycle = 0	●	0.80	0.90	1.08	V
				0.60		1.25	V
				0.40	0.45	0.54	V
V_{FB}	Flyback Reference Voltage	$I_{FB} = 50\mu\text{A}$	●	15.0	16.3	17.6	V
				14.0		18.0	V
V_{FB}	Change in Flyback Reference Voltage	$0.05 \leq I_{FB} \leq 1\text{mA}$		4.5	6.8	8.5	V
	Flyback Reference Voltage Line Regulation	$I_{FB} = 50\mu\text{A}$ $3\text{V} \leq V_{IN} \leq V_{MAX}$			0.01	0.03	%/V
	Flyback Amplifier Transconductance (gm)	$\Delta I_C = \pm 10\mu\text{A}$		150	300	650	μmho
BV	Output Switch Breakdown Voltage	$3\text{V} \leq V_{IN} \leq V_{MAX}$ $I_{SW} = 5\text{mA}$	●	15	32	70	μA
			●	25	40	70	μA
V_{SAT}	Output Switch ON Resistance (Note 1, 3)	$T_J \leq 100^{\circ}\text{C}$ $T_J \leq 125^{\circ}\text{C}$			0.12	0.18	Ω
						0.22	Ω
	Control Voltage to Switch Current Transconductance			12		A/V	

ELECTRICAL CHARACTERISTICS $V_{IN} = 15V$, $V_C = 0.5V$, $V_{FB} = V_{REF}$, switch pin open, unless otherwise noted.

SYMBOL	PARAMETER	CONDITIONS	MIN	TYP	MAX	UNITS
I_{LIM}	Switch Current Limit (LT1270) (Note 3)	Duty Cycle = 50%, $T_J \leq 100^\circ C$	●	8	16	A
		Duty Cycle = 80%, $T_J \leq 100^\circ C$	●	6	14	A
I_{LIM}	Switch Current Limit (LT1270A) (Note 3)	Duty Cycle = 50%, $T_J \leq 100^\circ C$	●	10.0	16.0	A
		Duty Cycle = 80%, $T_J \leq 100^\circ C$	●	7.5	14.0	A
$\frac{\Delta I_{IN}}{\Delta I_{SW}}$	Supply Current Increase During Switch-ON Time			25	40	mA/A
f	Switching Frequency		●	50	70	kHz
				50	70	kHz
DC_{MAX}	Maximum Switch Duty Cycle			80	92	%
	Flyback Sense Delay Time				1.5	μs
	Shutdown Mode Supply Current	$3V \leq V_{IN} \leq V_{MAX}$, $V_C = 0.05V$		100	400	μA
	Shutdown Mode Threshold Voltage	$3V \leq V_{IN} \leq V_{MAX}$	●	100 50	250 300	mV mV

The ● denotes specifications which apply over the full operating temperature range.

Note 1: Measured with V_C in Hi Clamp, $V_{FB} = 0.8V$.

Note 2: For duty cycles (DC) between 50% and 80%, minimum guaranteed

switch current is given by $I_{LIM} = 6.67 (1.7 - DC)$ for the LT1270 and $I_{LIM} = 8.33 (1.7 - DC)$ for the LT1270A.

Note 3: Minimum current limit is reduced by 0.5A at 125°C. 100°C test limits are guaranteed by correlation to 125°C tests.

TYPICAL PERFORMANCE CHARACTERISTICS

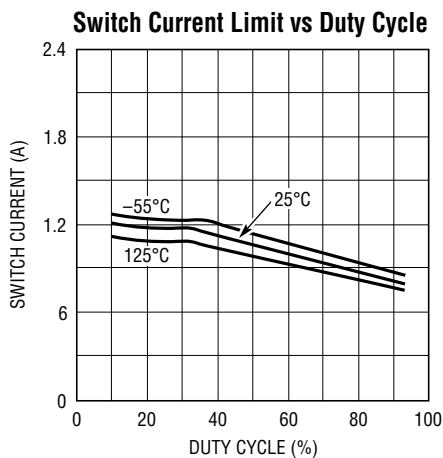

LT1270 • TA03

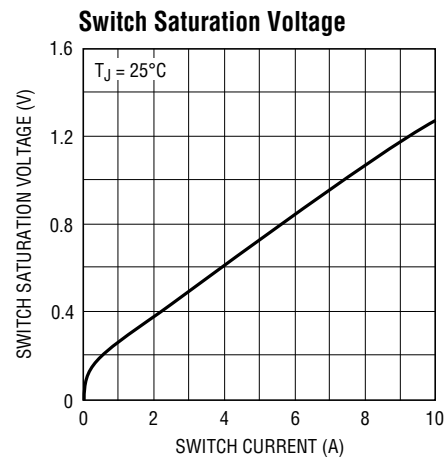

LT1270 • TA04

TYPICAL APPLICATIONS

Boost Converter (5V to 12V)

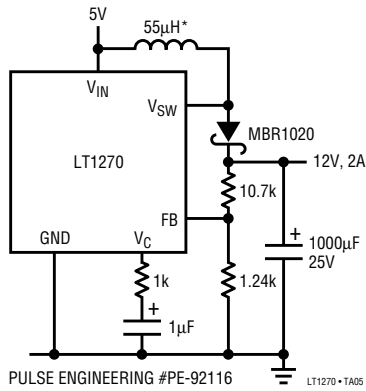

Negative-to-Positive Buck-Boost Converter

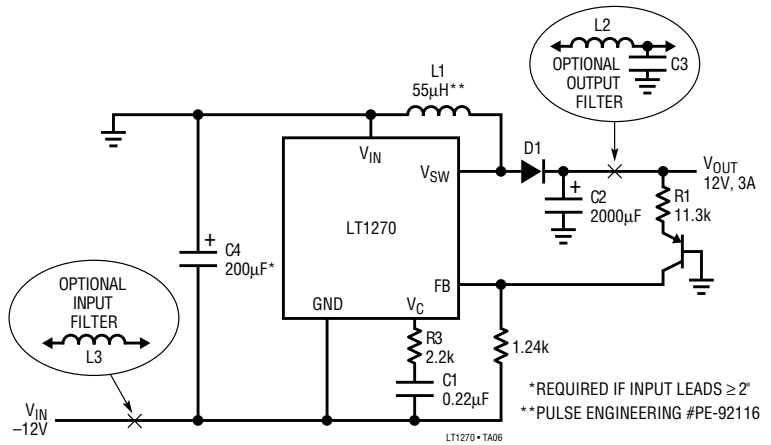

Negative Buck Converter

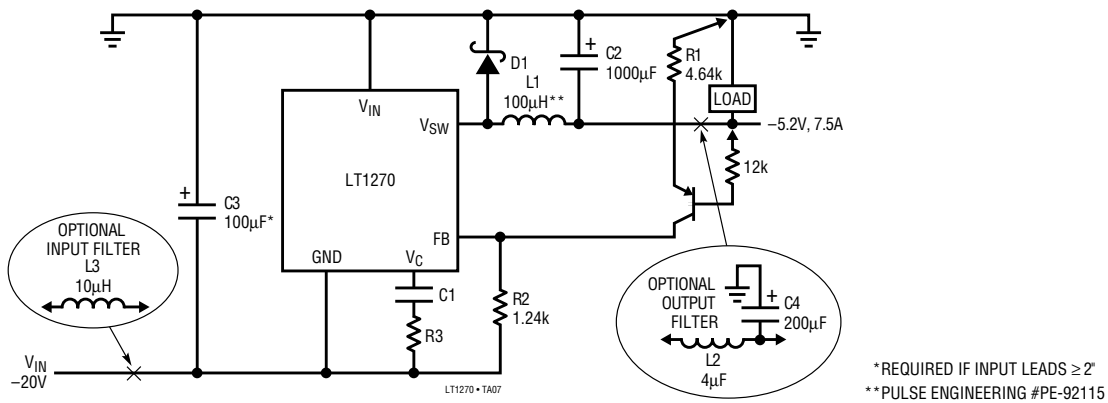

PACKAGE DESCRIPTION

Dimensions in inches (millimeters) unless otherwise noted.

