

Dot Matrix LED Unit for Outdoor Use LT1447M(Lamp Type)

■ Features

- No. of dots : 16X16dots
- Outline dimensions : 144X144mm
- Dot size : ϕ 7.5mm
- Dot pitch : 9.0mm
- Radiation color : Yellow-green+Red(High-luminosity)dichromatic type
- Driving method : 1/8 duty dynamic drive



LT1447M

■ Absolute Maximum Ratings

(Ta=25°C)

Parameter	Symbol	Rating	Unit
Supply voltage for IC	VCC	-0.3 to +6.0	V
Supply voltage for LED	VLED	-0.3 to +5.5	V
Input voltage	VI	-0.3 to VCC+0.3	V
Turn-on time	ton	1	ms
Operating temperature	Topr	-10 to +45	°C
Storage temperature	Tstg	-25 to +85	°C
Power dissipation	P	35	W

■ Optical Characteristics

(VCC=5V, VLED=5V, Ta=25°C)

Parameter	Symbol ²	TYP	Unit
Viewing angle	2 θ 1/2	40	°
Peak emission wavelength	Red	660	nm
	Yellow-green	565	

■ Luminance

Luminance is classified into 2 ranks shown below.

(VCC=5V, VLED=5V, Ta=25°C)

Radiation color	Rank		Unit
	1	2	
Red	600	800	cd/m ²
Yellow-green	750	1 000	

■ Terminal Functions

Connector	Symbol	Function
Power supply (CN1)	VLED	Supply voltage for LED(+5V)
	Vcc	Supply voltage for IC(+5V)
	GND1	Ground for IC
	GND2	Ground for LED
Input signal (CN2)	A0 to A2	Address specification signal for column driver Controls ON/OFF of red LED (H: LED OFF)
	RENABLE	Serial data input for red(H=ON, L=OFF) Shift from up to down in the unit HD16→HD31→HD0→HD15
	RDATA	Serial data input for yellow-green(H=ON, L=OFF) Shift from up to down in the unit HD16→HD31→HD0→HD15
	GDATA	Latch signal of display data H: Serial data is converted to parallel data. L: Contents are latched.
	LATCH	Controls ON/OFF of yellow-green LED (H: LED OFF)
	GENABLE	Clock signal for data transmission in the shift-register.(L→H: serial data is shifted.)
	CLOCK	Ground for signal (Connected to ground for IC)
	GND1	Ground for signal (Connected to ground for IC)
Output signal (CN3)	A0 to A2	Buffered input signal
	RENABLE	Buffered input signal
	RDATA	Input signal generated through 32-bit shift register
	GDATA	Input signal generated through 32-bit shift register
	LATCH	Buffered input signal
	GENABLE	Buffered input signal
	CLOCK	Buffered input signal
GND1	Ground for signal (Connected to ground for IC)	

Each signal is used as input signal for next unit.

* As for the terminal number, refer to the outline dimensions.

■ Electrical Characteristics

(VCC=5V, VLED=5V, Ta=25°C)

Parameter	Symbol	MIN.	TYP.	MAX.	Unit
Supply voltage for IC	VCC	4.75	5.0	5.25	V
Supply voltage for LED	VLED	4.5	5.0	5.25	V
IC current dissipation	ICC	—	270	350	mA
LED current dissipation ^{*1}	ILED	—	5.0	6.0	A
Input voltage	VIH	3.5	—	—	V
	VIL	—	—	1.5	V
Input current	IIH	—	—	0.1	μ A
	IIL	—	—	0.12	mA
Clock frequency	fCLK	—	—	3.0	MHz
Frame frequency	fFR	125	200	—	Hz

*1 Under the condition that dichromatic all dots are lit.

■ Timing Chart

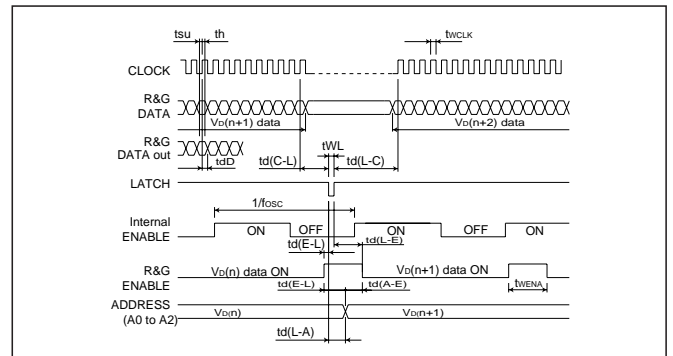

■ Block Diagram

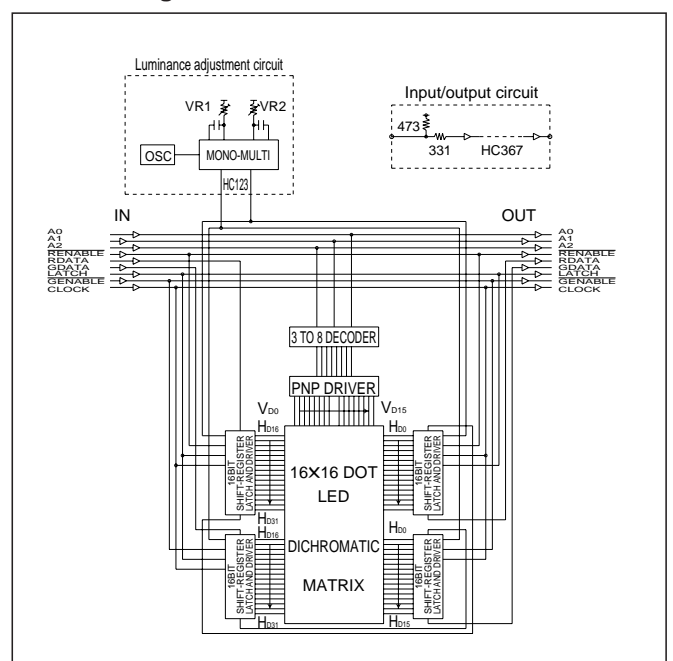

(Notice) • In the absence of confirmation by device specification sheets, SHARP takes no responsibility for any defects that may occur in equipment using any SHARP devices shown in catalogs, data books, etc. Contact SHARP in order to obtain the latest device specification sheets before using any SHARP device.

(Internet) • Data for sharp's optoelectronic/power device is provided for internet.(Address <http://www.sharp.co.jp/ecg/>)

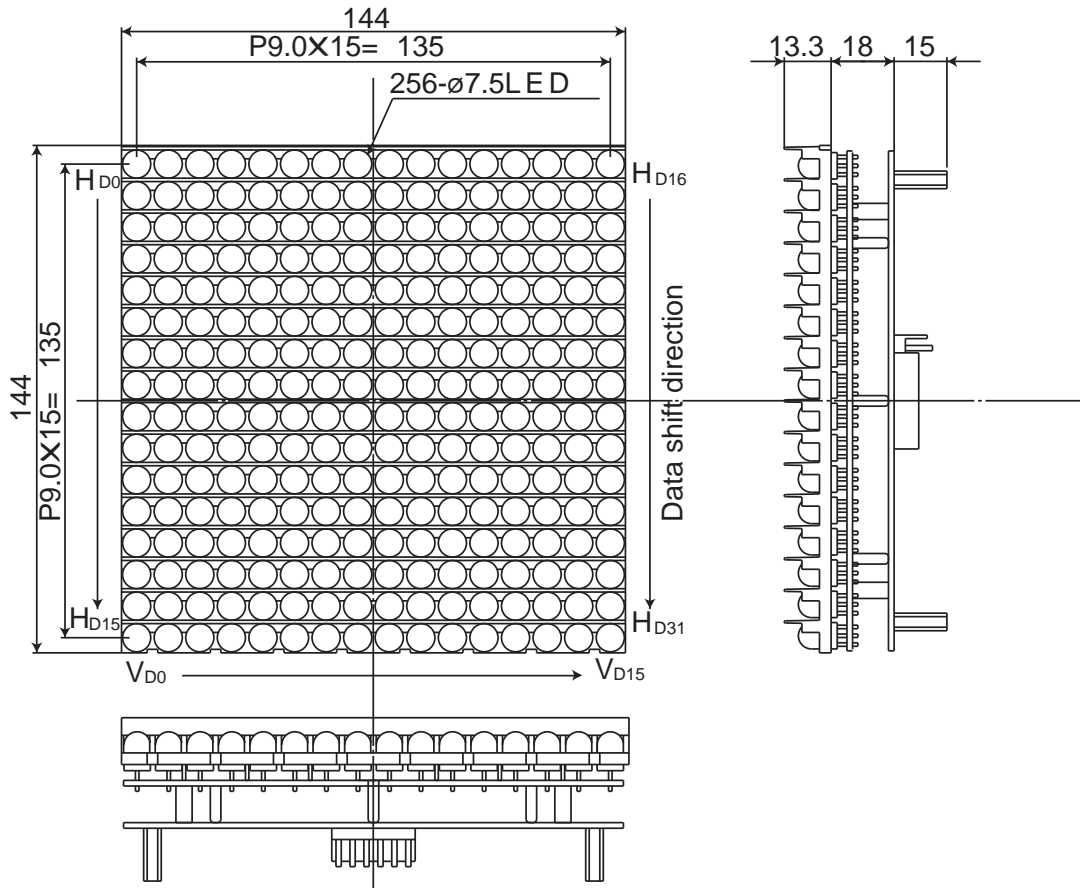

Hexagonal spacer ASB315
4-M3(Depth 6MIN.)

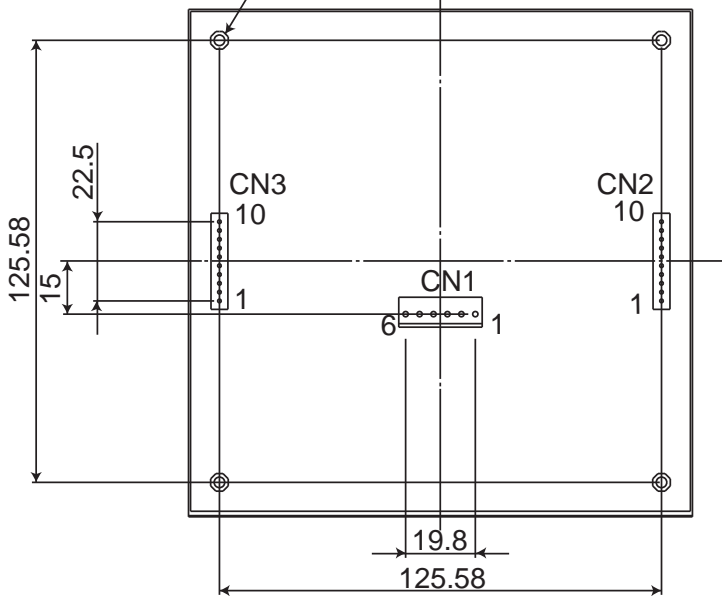

Pin connection

CN1(Power supply)

1	VLED
2	VLED
3	VDD
4	GND1
5	GND2
6	GND2

CN2(Input signal)

1	Ao
2	A1
3	A2
4	RENABLE
5	RDATA
6	GDATA
7	LATCH
8	GENABLE
9	CLK
10	GND1

CN3(Output signal)

1	Ao
2	A1
3	A2
4	RENABLE
5	RDATA
6	GDATA
7	LATCH
8	GENABLE
9	CLK
10	GND1